

# Development of modified micro computed

*by* Ian Yulianti

---

**Submission date:** 10-Apr-2023 06:49AM (UTC+0700)

**Submission ID:** 2059891240

**File name:** 2019\_Development\_of\_modified\_micro\_computed.pdf (763.44K)

**Word count:** 1661

**Character count:** 8720

PAPER · OPEN ACCESS

## Development of modified micro computed tomography system for nondestructive testing

To cite this article: Susilo *et al* 2019 *J. Phys.: Conf. Ser.* **1321** 032113

View the [article online](#) for updates and enhancements.

### You may also like

- [An image-based skeletal dosimetry model for the ICRP reference adult female—internal electron sources](#)  
Shannon E O'Reilly, Lindsay S DeWeese, Matthew R Maynard *et al.*
- [MicroCT imaging dose to mouse organs using a validated Monte Carlo model of the small animal radiation research platform \(SARRP\)](#)  
Christopher Daniel Johnstone and Magdalena Bazalova-Carter
- [Phase-contrast microtomography: are the tracers necessary for stem cell tracking in infarcted hearts?](#)  
Alessandra Giuliani, Mara Mencarelli, Caterina Frati *et al.*



**ECS** The Electrochemical Society  
Advancing solid state & electrochemical science & technology

## 242nd ECS Meeting

Oct 9 – 13, 2022 • Atlanta, GA, US

Early hotel & registration pricing ends September 12

Presenting more than 2,400 technical abstracts in 50 symposia

The meeting for industry & researchers in

**BATTERIES**  
**ENERGY TECHNOLOGY**  
**SENSORS AND MORE!**

 Register now!

 **ECS Plenary Lecture featuring M. Stanley Whittingham,**  
Binghamton University  
Nobel Laureate –  
2019 Nobel Prize in Chemistry



## Development of modified micro computed tomography system for nondestructive testing

Susilo<sup>1</sup>, Mosik<sup>1</sup>, T Darsono<sup>1</sup>, R Setiawan<sup>2</sup> and I Yulianti<sup>1,\*</sup>

<sup>1</sup>Physics Department, Faculty of Mathematics and Natural Sciences, Universitas Negeri Semarang, Indonesia

<sup>2</sup>STIKES An-Nasher Kaliwadas, Sumber, Cirebon, West Java Indonesia

\*Corresponding author: ianyulianti@gmail.com

**Abstract.** This paper presents a development of micro Computed Tomography (microCT) imaging system based on digital radiography. The system comprises stepper motor, CMOS detector, microcontroller and digital radiography unit. Scanning process was done by rotating the object while exposing its cross-sectional surface to X-ray radiation. The object was rotated by using stepper motor controlled by microcontroller. The normal of cross-sectional surface taken as the rotation axis. Therefore, a number of 2D image slices were obtained by rotating the object from 0° to 360°. The 2D image slices were then reconstructed to form 3D image using computer. By using the proposed microCT, analysis of surface and internal of the object can be done in 3D image and 2D image (slice) for nondestructive testing (NDT) application.

### 1. Introduction

Non-destructive testing (NDT) is an interesting method in evaluating material or system since it does not caused any damages to the object being analysed. One of popular methods in NDT is X-ray micro computed tomography (microCT). MicroCT is interested since it provides high resolution 3D image up to micrometer range which allows researchers to study sample morphology and its features such as density, particle size and porosity. Originally, MicroCT was used in medical application such as to evaluate bone resorption [1], brain cancer imaging [2] and microarchitecture of maxilla [3]. However, recently, the usage of microCT has changed from a qualitative imaging to a quantitative measurement [4]. In NDT application, microCT has been used to observe failure in lithium ion-battery [5], dentinal crack [6] and carbon nanotube morphology [7].

Due to its wide applications, microCT equipment is highly demanded for research and medical purposes. However, microCT is a high cost equipment so that research institutions and medical clinics with small fund could not afford it. In this work we propose a modified microCT equipment by modifying a conventional radiography. The conventional radiography was first modified to be digital radiography by using intensifying screen, light tube and digital camera [8]. Then, to build microCT using the modified digital radiography, we implement stepper motor to rotate the object which is controlled by Arduino microcontroller. By utilizing the existing conventional radiography, we obtain low cost microCT equipment which is suitable for small clinics and small research institutions.



Content from this work may be used under the terms of the [Creative Commons Attribution 3.0 licence](https://creativecommons.org/licenses/by/3.0/). Any further distribution of this work must maintain attribution to the author(s) and the title of the work, journal citation and DOI.

Published under licence by IOP Publishing Ltd

## 2. Methods

The system comprises stepper motor, CMOS detector, microcontroller and digital radiography unit. Scanning process was done by rotating the object while exposing its cross-sectional surface to X-ray radiation. The object was rotated by using stepper motor controlled by microcontroller. The normal of cross-sectional surface taken as the rotation axis. Therefore, a number of 2D image slices were obtained by rotating the object from 0° to 360°. The 2D image slices were then reconstructed to form 3D image using computer. Image processing is done by a computer using Matlab-based image software.

The RD imaging system has been modified into a system micro-CT to find out the surface and internal details of objects tested, by putting an object between the X-ray source and detector CMOS and wiper IGUs rotate the object, as shown in Figure 1.

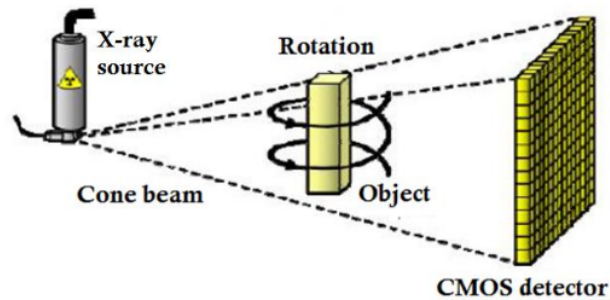

**Figure 1.** Schematic diagram of micro CT [9].

### 2.1. X-ray generator

The main unit in the CT system is the X-ray generator. The X-rays produced by regulating exposure factor (kV, mA, s, distance) on the control table. The resulting X-ray beam was exposed to the sample, resulting in a 2D radiograph. The X-ray source used in this experiment is a mobile X-ray plane with an X-ray tube that emits an X-ray beam. The X-ray emits cone beam shape where the origin of the X-rays are spots focus on the target metal and the light emitted spreads towards the sample or object.

### 2.2. Sample Rotation to obtain sequential projection images

The sample or object is positioned above a horizontal plane, then the object is rotated using a stepper motor controlled by Arduino micro controller with the specified viewpoint, as shown in Figure 2 [10]. For in vivo scanning, to obtain sequential images, it is the X-ray source pair and detector that are rotated. At each scanning step, new projection image is recorded. The scanning and image recording are done during sample rotation from 0° to 360°.

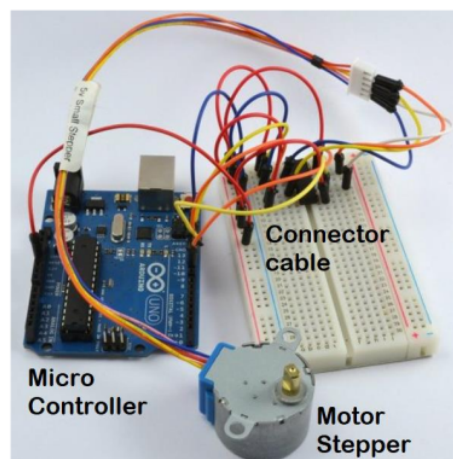

**Figure 2.** Stepper motor with arduino micro controller [10].

### 2.3. Reconstruction of Projection Images into Virtual Slices

The computational process of information on the internal structure of the projected image is known as reconstruction. This procedure produces heap image reconstruction (also referred to as "cross-sectional images" or "slices (slices)"). The results of the X-ray capture by the CMOS detector are then reconstructed into a series of two-dimensional axial slices, which each pixel in the slices provides information on how much X-rays are absorbed by the organ represented by the pixel. This cross section can then be used to view internal features, analyzed and then reconstructed into virtual 3D models. The image acquisition process was carried out using Matlab application -based software. The digital images stored on the server can be accessed and processed using image processing software which was developed using Matlab.

### 3. Results and Discussion

The stepper motor was first optimized to obtain an optimum rotational angle of each step. It was obtained that the rotational angle of each step is  $1.4^\circ$  with 3.125 % of error. Hence, rotation of the stepper motor is quite linear and thus suitable to be used to rotate objects on a microCT system. The developed acquisition system to capture a projection image of each  $1.4^\circ$  rotational angles is shown in Figure 3. The radiographic results or so-called acquisition images were taken from each X-ray exposure and changes in the rotation of a stepper motor controlled by a microcontroller with an exposure factor of 0.20 s, 50 kV and 16 mA. The acquisition images containing 256 images were stored on a PC hard drive that were then used for reconstruction processes. In this work, we used a phantom as a sample. The phantom radiographs at the 128<sup>th</sup> step is shown in Figure 4.

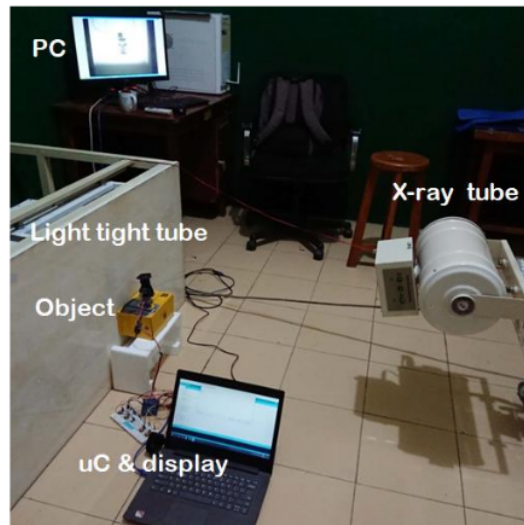

**Figure 3.** MicroCT acquisition system



**Figure 4.** Phantom image with exposure factors of 50kV, 0.2 s and 16 mA.

Reconstruction was then performed to the phantom images obtained from the whole rotation steps. The reconstructed image of the phantom is shown in Figure 5. It is clearly shown that there are many noises in the image. To remove the noises, the image was filtered and segmented. The 3D image after filtering process is shown in Figure 6. It is shown that the noise has been removed leaving a clear image of the phantom.

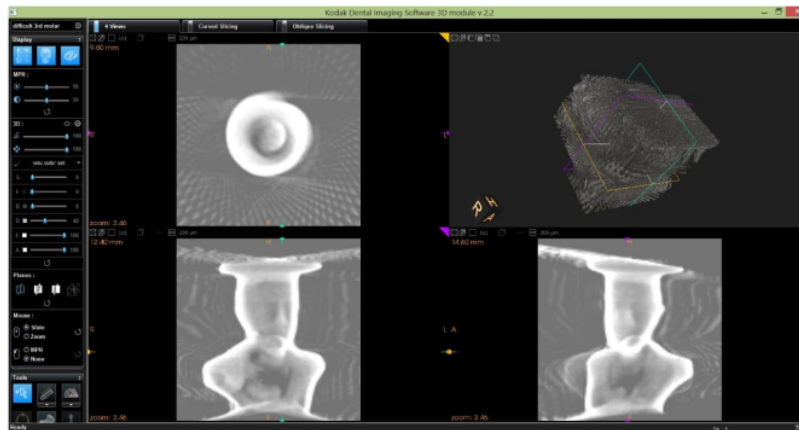

Figure 5. Reconstruction results of phantom object.

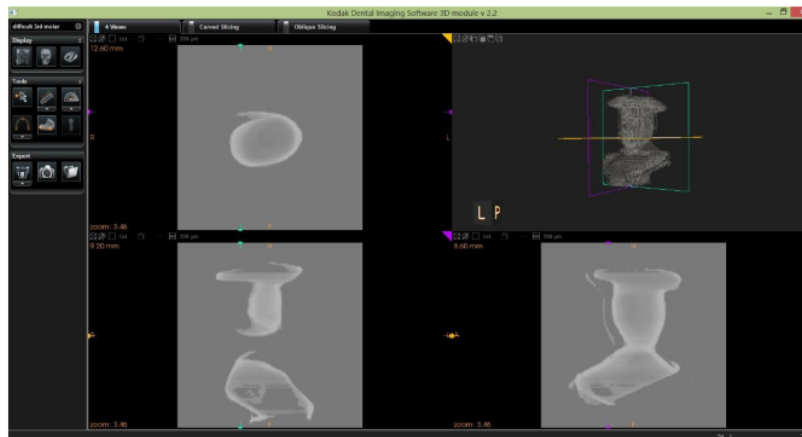

Figure 6. 3D reconstruction results with filters and segmentation.

#### 4. Conclusion

The modified microCT system has been designed. It was demonstrated that the system perform well in terms of acquisition system and image processing system. The system also provides low cost and easy operation.

#### Acknowledgments

We would like to thank to the members of Physics Department, Universitas Negeri Semarang for their helpful discussion throughout the completion of this work.

#### References

- [1] Tsutsumi T, Kajiyu H, Tsuzuki T, Goto K T, Okabe K and Takahashi Y 2018 *J. Prosthodont. Res.* **62** 298
- [2] Barbone G E *et al.* 2018 *Int. J. Radiat. Oncol.* **101** 965
- [3] Kulah K *et al.*, 2019 *Oral Surg. Oral Med. Oral Pathol. Oral Radiol.* **127** 247
- [4] du Plessis A, le Roux S G, Els J, Booysen G and Blaine D C 2015 *Case Stud. Nondestruct. Test.*

*Eval. 4 1*

- [5] Chen C, Wei Y, Zhao Z, Zou Y and Luo D 2019 *Electrochim. Acta* **305** 65
- [6] Zuolo M L *et al.* 2017 *J. Endod.* **43** 619
- [7] Li Q 2014 *Mater. Lett.* **133** 83
- [8] Susilo, Yulianti I, Addawiyah I and Setiawan R 2018 *IOP Conf. Ser. J. Phys. Conf. Ser.* **983**
- [9] Cantatore A and Müller P 2011 *Introduction to computed tomography* (Kgs.Lyngby: DTU Mechanical Engineering)
- [10] Li H, Zhang H, Tang Z and Hu G 2008 *Prog. Nat. Sci.* **18** 513



# Development of modified micro computed

---

## ORIGINALITY REPORT

---

16%

SIMILARITY INDEX

6%

INTERNET SOURCES

16%

PUBLICATIONS

9%

STUDENT PAPERS

---

## MATCH ALL SOURCES (ONLY SELECTED SOURCE PRINTED)

---

9%

★ Xiangke Li, Hai Yang, Guojun Jin. "Strain-Modulated Electronic and Thermal Transport of Monolayer Black Arsenic Phosphorus", Journal of Physics: Conference Series, 2023

Publication

---

Exclude quotes  On

Exclude matches  < 4 words

Exclude bibliography  On

# Development of modified micro computed

---

GRADEMARK REPORT

---

FINAL GRADE

**/0**

GENERAL COMMENTS

**Instructor**

---

PAGE 1

---

PAGE 2

---

PAGE 3

---

PAGE 4

---

PAGE 5

---

PAGE 6

---

PAGE 7

---