

# Development of CBCT system for medical-physics

*by* Ian Yulianti

---

**Submission date:** 10-Apr-2023 06:40AM (UTC+0700)

**Submission ID:** 2059884488

**File name:** 2020\_Development\_of\_CBCT\_system.pdf (732.38K)

**Word count:** 2527

**Character count:** 13430

PAPER · OPEN ACCESS

## Development of CBCT system for medical-physics laboratory improvement

To cite this article: Susilo *et al* 2020 *J. Phys.: Conf. Ser.* **1567** 022015

View the [article online](#) for updates and enhancements.

### You may also like

- [Cone-beam computed tomography-based delta-radiomics for early response assessment in radiotherapy for locally advanced lung cancer](#)  
Liting Shi, Yi Rong, Megan Daly et al.

- [A two-step method to improve image quality of CBCT with phantom-based supervised and patient-based unsupervised learning strategies](#)  
Yuxiang Liu, Xinyuan Chen, Ji Zhu et al.

- [A comprehensive evaluation of the accuracy of CBCT and deformable registration based dose calculation in lung proton therapy](#)  
Catarina Veiga, Guillaume Janssens, Thomas Baudier et al.

## Development of CBCT system for medical-physics laboratory improvement

Susilo<sup>1</sup>, T Darsono<sup>1</sup>, R Setiawan<sup>2</sup>, U A Taufiq<sup>1</sup>, I Yulianti<sup>1</sup> and Fianti<sup>1\*</sup>

<sup>1</sup> Department of Physics, Faculty of Mathematics and Natural Sciences, Universitas Negeri Semarang, Indonesia

<sup>2</sup> STIKES An-Nasher Cirebon, Indonesia

\*Corresponding author: [fianti@mail.unnes.ac.id](mailto:fianti@mail.unnes.ac.id)

**Abstract.** Films used in Rontgen aperture by conventional radiography process yielding a fluorescent-based digital radiography have been conducted in medical-physics laboratory, Unnes for several applications. The continued research was improving the 2D radiograph imaging to be 3D, *i.e.* the object was rotated and X-Ray radiated simultaneously that yielded a 2D radiograph data by reconstruction and rendering. These covered a development of simulation object, an algorithmic modeling of scanning simulation and FDK (Feldkamp, Davis, Kress), and finally utilizing the algorithms resulting in 3D radiograph. In the future, this cheap technology would be a benefit in dentistry, because this technology is not popular nowadays, an implication of the expensive cost. The development process covered; software developing stage of CBCT (cone beam computed tomography) system in Phantom, data analysis, and finally reaching the result: CBCT model in laboratory scale. Prototype development of CBCT system can be done through study of the system in laboratory scale and then integrating the CBCT system for validated system in laboratory scale. According to the background above, we need innovation in CBCT system supporting the development of CBCT system aperture that leads to ease the dental implant installation in dentistry. At this level, CBCT prototype was used in early validation of the concept of CBCT technology in limit quantity and laboratory scale.

### 1. Introduction

Radiological examination is one of the examinations needed to determine the treatment plan and even the successful installation of dental implants [1]. 3-dimension cone beam computed tomography (3D CBCT) is a high resolution radiography tool to meet the information needs in the installation of dental implants [2]. The tool produces 3D image that includes axial, coronal, and sagittal fields and can measure bone density. The results were density charts with maximum and minimum values, as well as differences in color mapping to give the value of the jawbone density of each voxel, completed by some visualization to measure bone quality [3].

The application of 3D CBCT tools in dentistry can be used during implant placement, examination of facial oromaxillary abnormalities and temporomandibular joints, orthogenetic surgery, impacted dental cases, bone abnormalities, trauma to the upper and lower jaw, and evaluation of sinus disease [4-5]. One factor that plays an important role in the installation of dental implants is the accuracy of the calculation of the quality and quantity of the jawbone to determine whether the patient is an indication or contra indication, treatment plan, and evaluation of the success of dental implant



Content from this work may be used under the terms of the [Creative Commons Attribution 3.0 licence](https://creativecommons.org/licenses/by/3.0/). Any further distribution of this work must maintain attribution to the author(s) and the title of the work, journal citation and DOI.

installation. Unfortunately, the use of X-ray equipment including 3D CBCT by dentists and dentist specialists is still low. Failures and complications of implantation are also still common. In developed countries the failure rate has been reported to reach 20%. One of the implant failures and complications can be caused by improper placement of the implant and biological factors [6]. Biological factors, namely poor bone quality, insufficient bone volume, planning errors in implant placement, and errors in assessing bone anatomy, which results in obstruction of osseointegration. Fatal complications, namely the occurrence of bleeding caused by perforation of solid bone that usually occurs in the lingual area of the mandible.

The failure of dental implants not only causes financial loss, but also affects the condition of the jawbone of the patient which can even have a psychological impact on the patient. Placement of the implant into the jaw carries a high risk; if the planning is incorrect and inaccurate it will cause damage to anatomical structures such as the mandibular canal and maxillary sinus. Risks that can cause the failure of dental implant treatment must be anticipated by carrying out an appropriate and accurate treatment plan. To support the right treatment plan, information of some interpretation from high-resolution digital technologies such as 3D CBCT is needed. Implant practitioners can examine from various aspects accurately and more clearly in just one shot, through 3D CBCT [7-9].

This research was carried out the development of innovative CBCT system based on intensifying screen. The benefits of these innovations can be used as national products that will be able to compete with foreign products to reduce import dependency and improve public health services.

## 2. Methods

The reasearch was started by system design. The system included building the object simulation, modeling the scanning simulation algorithms and FDK (Feldkamp, Davis, Kress) algorithms [10-11]. Then continued by system implementation. Here, the systems were implemented in software resulting some data collection. These were carried out by lab technicians and medical physicists by preparing phantom and operating the radiograph intake by phantom rotation 1-360°. Then, the reconstruction algorithms were tested by projection data. Finally, this works resulted a prototype. The process of making 3D CBCT techniques is in accordance with the flow diagram in Figure 1.

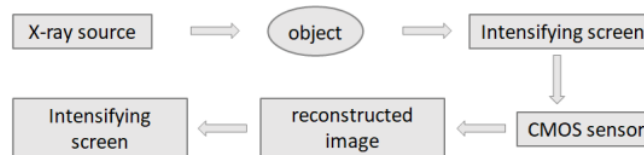
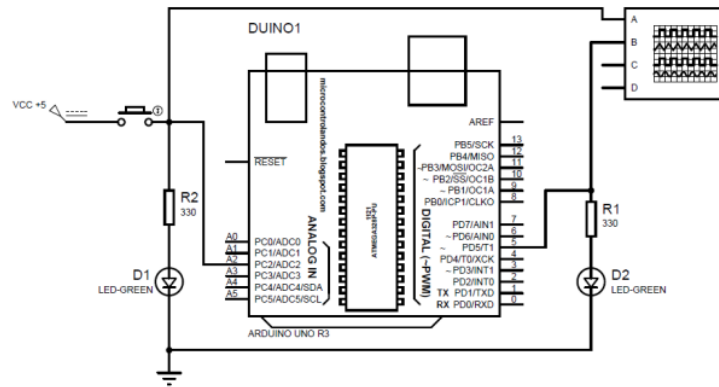

Figure 1. Flow diagram of the 3D CBCT system development

## 3. Result and Discussion

### 3.1. Delay Set of Image Capture Unit Optimization

The tool to trigger the camera and delay the Radig consists of an Arduino, two 330 ohm resistors, a push button (NO) with a 5 V source. The trigger was connected to the analog pin A2 and Arduino output on the digital pin 5. The trigger directly triggered the camera (D1) and Radig (D2) with a delay of 1 second on Radig before activating. The connection diagram of the camera trigger and Radig was shown in Figure 2.



**Figure 2.** Connection diagram of the camera trigger and Radig

```

const int buttonPin = A2;
const int ledPinA = 5;
int buttonState = 0;

void setup() {
  pinMode(ledPinA, OUTPUT);
  pinMode(buttonPin, INPUT);
  digitalWrite(buttonPin, LOW);
}

void loop() {
  buttonState = digitalRead(buttonPin);
  if (buttonState == HIGH) {
    delay (1000);
    digitalWrite(ledPinA, HIGH);
  } else {
    digitalWrite(ledPinA, LOW);
  }
  delay (50);
}
    
```

**Figure 3.** Sketch of the camera trigger and Radig

Sketch was set to give a delay of 1 second on digital output 5 connected to Radig, as shown in Figure 3. Before the delay circuit was built, the circuit has been simulated by using a proteus lunat device. The circuit was connected to a virtual oscilloscope to observe the pulse when the camera was given a trigger so that it produced a delay to give a trigger to the Radig unit. Virtual oscilloscope was set 2 volts/div and 0.5 s/div. Voltage and delay can be obtained by calculating the div on the oscilloscope screen. The channel voltages A and B were,  $2.5 \text{ div} \times 2 \text{ volt/div} = 5 \text{ V}$  and the period was  $2 \text{ div} \times 0.5 \text{ s/div} = 1 \text{ s}$ . The pulse delay results were displayed on the virtual oscilloscope.

### 3.2. System Design and Implementation

This section explained the application of system design, methods, operations, and algorithms used in developing CBCT systems [12]. The system designed aimed to examine the potential of the CBCT system in producing cross-sectional images of an object. This system was started by a general explanation of the system designed, which was in the form of a block diagram of the whole system, then proceed with a discussion of system implementation that contains an explanation of the system specifications and methods, as well as, the algorithms that was used to implement each part of the system. In the data processing section, an explanation of the flow chart was given, as well as what MATLAB M-files were used, both those already provided by MATLAB and those that were self-built.

### 3.3. System Planning

The designed system aims were to apply the CBCT system in producing 3D images. The system input was an X-ray image exposing the object, and the output was a 3D radiograph of the object. 3D

radiograph images not only providing information on the surface of the object (external), but also provide information on the inside (internal) of the object. If this radiograph image was splitted, a cross-section of the object would be obtained. The system specifications consisted of X-ray source, intensifying screen as an X-ray sensor, turntable object, experimental object, and computers for data processing (with hardware: Dual Core Intel Core i5 Processor, 4G RAM, 64 GB Hard Disk and software: Microsoft Windows 7, MATLAB 2014).

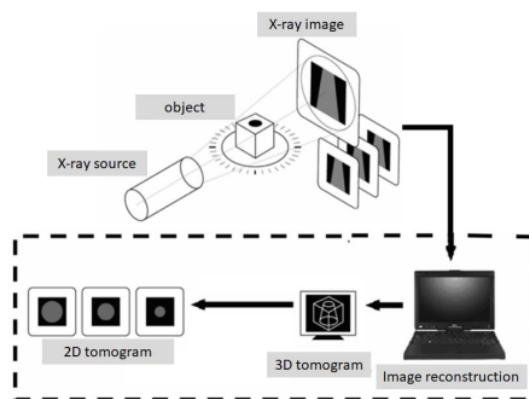

Figure 4. Simulated CT system built in this study.

#### 3.4. X-ray Source

The source of X-rays used in this study was the X-ray generator in the medical-physics laboratory, Unnes. This X-ray source can be used for the purposes of learning diagnostic radiography and non-destructive testing. In this study the object used was the skull phantom object, so the X-ray dose used was not a problem. The specifications of the X-ray source used in the experiment were 70 kV X-ray source tube, 5 mA tube current, and 1.6 s exposure time. Since the required X-ray beam was a cone beam, the collimator was opened wide in this experiment.

#### 3.5. X-ray detector

In this experiment as an X-ray detector was a fluorescent screen (Intensifying Screen) that changed the X-ray into visible light, the role of film was no longer needed [13]. Intensifying screen was rectangular in shape with a size of approximately  $40 \times 30 \text{ cm}^2$ .

#### 3.6. Turntable Object

A turntable object was a device designed to take X-ray attenuation data through an object [14]. There were several data collection methods, depended on the type of tomography used. In this study, cone tomography transmission was used. The transmission technique was used because computationally the results of shooting images on the phosphorescent layer by a DSLR camera were easier to proceed. Generally, tomography used X-ray. The parameter used in this CBCT was the X-ray attenuation parameter. Cone tomography provided advantages such as speed of data retrieval, reduction of radiation time, without collimator adjustment [15].

#### 3.7. Reconstruction Results

Data was collected by photographing the phantom skull (Figure 5(a)) 257 times to obtain a radiographic projection image from an angle of  $0\text{-}360^\circ$ . Radiographic data that has been obtained from the capture of digital radiographic image was then processed into the reconstruction phase, Figure 5(b) The reconstruction process was carried out to get an inner cut called a slice.





Figure 5. (a) Phantom skull and (b) examples of radiographs from various shooting angles

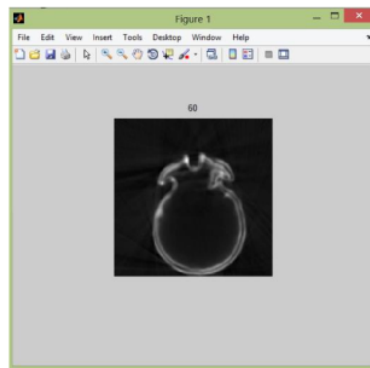

Figure 6. One reconstruction image, the result of reconstruction of a radiograph projection head image

The reconstruction process was carried out by applying the FDK algorithms with ram-litter filter so that the reconstructed image was obtained as shown in Figure 6. The results of the reconstruction are carried out by segmentation process to eliminate unneeded parts. The reconstruction image from the radiograph was converted into a 16-bit image and then saved in a dicom format, Figure 7. The computerized image was then imported into a special CBCT viewer so that it can display per-slice images including 3D images rendered from reconstruction images. The 3D image was shown in Figure 7.



**Figure 7.** Reconstruction image after conversion to 16-bit data in dicom format**Figure 8.** (a) 2D and 3D reconstruction results from several sides, (b) the results of full screen 3D reconstruction

Figure 8 showed that the results of the basic research were close to the original phantom. The results of this basic research would be developed by increasing the resolution so that 3D images that can be measured precisely in the best spatial resolution range.

#### 4. Conclusion

The CBCT development system test including a detector system was able to provide high resolution results yielding reconstruction results without shape degradation, which was influenced by the optimal order delay, as well as, by image filter during the projected image reconstruction process. The results of reconstruction with the FDK algorithm and ram-litter filter showed 3D results that were close to the original object.

#### References

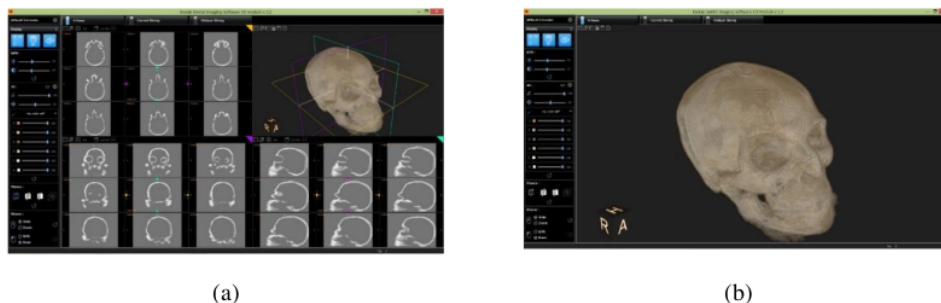
- [1] Keerthna M and Jain A R 2018 *Drug Invention Today* **10** 748
- [2] Jacobs R, Salmon B, Codari M, Hassan B and Bornstein M M 2018 *BMC Oral Health* **18** 1
- [3] Dawood A, Patel S and Brown J 2009 *British Dental Journal* **207** 1
- [4] Pramanik F & Firman R N 2015 *Dentofasial* **14** 50
- [5] Anni S, Esmacili E P and Robinson S 2015 *Insights Imaging* **6** 1
- [6] Levin L 2008 *J Appl Oral Sci.* **16** 171
- [7] Lorenzoni D C, Bolognese A M, Garib D G, Guedes F R and Sant'Anna E F 2012 *International Journal of Dentistry* **2012** 1
- [8] Jaju P P & Jaju S P 2014 *Clinical, cosmetic and investigational dentistry* **6** 29
- [9] Kapila S, Conley R S and Harrell W E 2011 *Dento maxillo facial radiology* **40** 24
- [10] Ngoc L D and Du Y C 2019 *Electronics* **8** 1381
- [11] Pauwels R, Araki K, Siewerdsen J H and Thongvigitmanee S S 2015 *Dento maxillo facial radiology* **44** 20140224
- [12] Miracle A C and Mukherji S K 2009 *AJNR Am J Neuroradiol* **30** 88
- [13] Susilo, Mosik, Darsono T, Setiawan R and Yulianti I 2019 *J. of Phys. Conf.* **1321** 032113
- [14] Susilo, Masturi, Susanti R, Yulianti I and Fatimah Q 2019 *J. of Phys. Conf.* **1170** 012076
- [15] David P. Sarment, Angi M. Christensen 2014 *J.of Forensic Radiology and Imag.* **2** 173



# Development of CBCT system for medical-physics

---

## ORIGINALITY REPORT

---

10%

SIMILARITY INDEX

3%

INTERNET SOURCES

10%

PUBLICATIONS

6%

STUDENT PAPERS

---

## MATCH ALL SOURCES (ONLY SELECTED SOURCE PRINTED)

---

6%

★ F W Mahatmanti, W D P Rengga, E Kusumastuti, Nuryono. "Adsorption of Pb(II) ion from aqueous solution onto Chitosan/silica/polyethylene glycol (Ch/Si/P) composites membrane", IOP Conference Series: Materials Science and Engineering, 2017

Publication

---

Exclude quotes  On

Exclude matches  < 4 words

Exclude bibliography  On

# Development of CBCT system for medical-physics

---

GRADEMARK REPORT

---

FINAL GRADE

**/0**

GENERAL COMMENTS

**Instructor**

---

PAGE 1

---

PAGE 2

---

PAGE 3

---

PAGE 4

---

PAGE 5

---

PAGE 6

---

PAGE 7

---