

PAPER • OPEN ACCESS

## Simulation study of $\text{Al}_2\text{O}_3\text{-H}_2\text{O}$ nanofluids as radiator coolant using computational fluid dynamics method

To cite this article: S Anis *et al* 2022 *IOP Conf. Ser.: Earth Environ. Sci.* **969** 012026

View the [article online](#) for updates and enhancements.

You may also like

- [Influence of solvents on the enhancement of thermophysical properties and stability of multi-walled carbon nanotubes nanofluid](#)  
Balaji Bakthavatchalam, Khairul Habib, R Saidur *et al.*
- [Experimental study and predicted model analysis of nanofluid wetting behavior under high voltage](#)  
Yanjun Chen, Youwei Wang, Jie Zhang *et al.*
- [Impulse performance of synthetic esters based-nanofluid for power transformer](#)  
Anu Kumar Das and Saibal Chatterjee



## ECS Membership = Connection

**ECS membership connects you to the electrochemical community:**

- Facilitate your research and discovery through ECS meetings which convene scientists from around the world;
- Access professional support through your lifetime career;
- Open up mentorship opportunities across the stages of your career;
- Build relationships that nurture partnership, teamwork—and success!

**Join ECS!**

**Visit [electrochem.org/join](https://electrochem.org/join)**



# Simulation study of Al<sub>2</sub>O<sub>3</sub>-H<sub>2</sub>O nanofluids as radiator coolant using computational fluid dynamics method

S Anis<sup>1</sup>, Y C Kayunda<sup>1</sup>, A Kusumastuti<sup>1</sup> and J P Simanjutak<sup>2</sup>

<sup>1</sup>Faculty of Engineering, Universitas Negeri Semarang, 50229 Gunungpati, Semarang, Central Java, Indonesia

<sup>2</sup>Mechanical Engineering Department, Universitas Negeri Medan, 20221 Medan Tembung, Medan, North Sumatera, Indonesia

samsudin\_anis@mail.unnes.ac.id

**Abstract.** The objective of this study was to investigate the influence of nanofluid concentration on the heat transfer rate of radiator pipes. This study used computational fluid dynamics simulation method of ANSYS Fluid Flow Fluent software. The working fluid used in this study was nanofluid prepared of Al<sub>2</sub>O<sub>3</sub> and H<sub>2</sub>O mixture. Simulation was performed at various Al<sub>2</sub>O<sub>3</sub> nanoparticles concentration ranging from 0 to 1%. The velocity and inlet temperature of nanofluid were set at 0.4 m/s and 130°C, respectively. The results of the simulation showed that the heat transfer rate and outlet temperature of nanofluid were influenced by the nanoparticles concentration. The rate of heat transfer increased with the increased of nanoparticles concentration. Among the tested concentration, 1% Al<sub>2</sub>O<sub>3</sub> provided better heat transfer activity in which it is capable to reduce the high inlet fluid temperature to become about 80°C, very close to the recommended working conditions.

## 1. Introduction.

Simulation is a special approach to studying models, which is fundamentally experimental. The principle of simulation is similar to running a field test, the simulation involves creating a model according to real conditions [1]. The simulation in this study relates to nanofluids as a radiator coolant. Radiator is a tool that serves as a tool to cool the working fluid (radiator coolant) that has absorbed heat from the engine by removing the heat of the working fluid through its cooling fins and assisted by the presence of fan to increase the speed of air flow, so that the heat energy transfer can be greater according to its needs [2,3]. Water as a fluid can cause dirty deposits in the cooling ducts and cause corrosion. Water will also freeze at low temperatures; this condition causes problems in fluid circulation [2,3]. Water has the potential to contain lime substances that can cause deposits in radiator pipes [2]. Nanofluid has been introduced to improve thermal conductivity, giving great hope to the field of heat transfer. Nanoparticles made from ultra-fine particles with a diameter of less than 100 nm have been shown that the performance and behaviour of materials changed significantly when created from nanoscales [4,5]. Preparation of nanofluid is done by mixing nano-sized particles with a fluid [3-6]. This study used computational fluid dynamic simulation method, which in simulating this experiment used ANSYS Fluid Flow Fluent software. Computational fluid dynamic is an efficient computational method for studying fluid mechanics based on numerical analysis [7,8].



Research conducted by Elsebay et al. [9] about the addition of Al<sub>2</sub>O<sub>3</sub> and CuO nanoparticles in water can increase the heat transfer rate of car radiators. The average increase in heat transfer coefficient depends on the number of nanoparticles added to pure water. The literature also shows fluid flow rate, inlet temperature, and nanofluid concentration provide significant effect on the improvement of heat transfer performance [10]. The thermal slip effect can also decrease the temperature of the fluid depending on the type of nanoparticle applied and is able to reduce the pumping power requirement [6,11].

Research conducted by researchers previously could not be known the exact condition of fluid flow conditions that occur during fluid flow from the side of the inlet and outlet. Therefore, simulation is needed that can provide more accurate information so as to improve the performance of the tool. The information needed to improve tool performance is increasing the heat transfer rate as long as the fluid flows from the inlet side to the outlet. Based on these problems, there needs to be research on the rate of heat transfer based on Computational Fluid Dynamics. Computational fluid dynamics or CFDs are system analyses involving fluid flow, heat transfer and related phenomena such as chemical reactions through computer-based simulations. CFD modelling consists of pre-processing, solving, and post processing. The objectives of this study are to investigate the influence of Al<sub>2</sub>O<sub>3</sub>-H<sub>2</sub>O nanofluid concentration on the rate of heat transfer in radiators using ANSYS Fluid Flow Fluent software. In this work, nanofluids are produced by dispersing Al<sub>2</sub>O<sub>3</sub> nano solid particles into H<sub>2</sub>O basic liquids with low thermal conductivity.

## 2. Materials and Methods

### 2.1 Thermophysical Properties of Nanofluid

Al<sub>2</sub>O<sub>3</sub> nano solid particles and water (H<sub>2</sub>O) were used as nano solid particles and base liquid fluid, respectively. They were mixed at various concentration to prepare nanofluid material for radiator coolant. In general, nanofluid has large heat transfer characteristics when compared to conventional fluids. Several nanofluid properties were then evaluated and used for simulation processes.

*2.1.1 Thermal conductivity of nanofluid.* Thermal conductivity of nanofluids is calculated based on the empirical correlation given by Xuan et al. [12] as shown in Equation 1.

$$k_{nf} = \frac{k_p + 2k_b - 2\phi(k_p - k_b)}{k_p + 2k_b + \phi(k_p - k_b)} k_b + \frac{\rho_p \phi C_{p_p}}{2} \sqrt{\frac{k_B T}{3\pi r_c \mu_{nf}}} \quad (1)$$

where  $k_{nf}$  is thermal conductivity of nanofluid (W/m.K),  $k_p$  is thermal conductivity of nano particle (W/m.K),  $k_b$  is thermal conductivity of basic fluid (W/m.K),  $k_B$  is Boltzmann constant ( $1.381 \times 10^{-23}$  J/K), and  $r_c$  is radius cluster ( $10^{-8}$  m).

*2.1.2 Specific heat.* Specific heat is the ratio of the amount of heat required to increase 1°C temperature of a substance. The specific heat can be evaluated as follows [13].

$$C_{p_{nf}} = \frac{(1-\phi)\rho_b C_{p_b} + \phi(\rho_p C_{p_p})}{\rho_{nf}} \quad (2)$$

where  $C_{p_{nf}}$  is specific heat of nanofluid (J/kg.K),  $C_{p_b}$  is specific heat of basic fluid (J/kg.K), and  $C_{p_p}$  is specific heat of nano particle (J/kg.K).

*2.1.3 Density.* Pak and Cho [14] suggested the following equation for nanofluids density determination:

$$\rho_{nf} = \phi\rho_p + (1-\phi)\rho_b \quad (3)$$

where  $\rho_{nf}$  is nanofluid density (kg/m<sup>3</sup>),  $\rho_p$  is nano particle density (kg/m<sup>3</sup>), and  $\phi$  is nano particle concentration or fraction.

**2.1.4 Viscosity.** Viscosity of fluids affects the resistance value of heat transfer. Viscosity of nanofluid can be determined as the following equation [15].

$$\mu_{nf} = \mu_b (1 + 7.3\phi + 123\phi^2) \quad (4)$$

where  $\mu_{nf}$  is nanofluid viscosity (kg/m.s), and  $\mu_b$  is basic fluid viscosity (kg/m.s).

**2.1.5 Convective heat transfer coefficient.** The coefficient of convective heat transfer in the radiator pipe can be calculated by the equation below.

$$h = \frac{Nu \times k}{D} \quad (5)$$

where  $h$  is convective heat transfer coefficient (W/m<sup>2</sup>.K),  $Nu$  is Nusselt number,  $k$  is thermal conductivity of material (W/m.K), and  $D$  is diameter of pipe (m).

Table 1 shows the basic thermophysical properties of the original materials used in this study, whereas Table 2 provides thermophysical properties of nanofluids for each concentration. Nanofluids with a concentration of 0.3% means that there is only 0.3% Al<sub>2</sub>O<sub>3</sub> in the fluid mixture.

**Table 1.** Basic thermophysical properties of Al<sub>2</sub>O<sub>3</sub> and H<sub>2</sub>O

Thermophysical Properties	H <sub>2</sub> O	Al <sub>2</sub> O <sub>3</sub>
Density (kg/m <sup>3</sup> )	998.21	3970
Specific Heat (J/kg.K)	4182	525
Thermal Conductivity (W/m.K)	0.6024	17.65

**Table 2.** Thermophysical Properties of nanofluids for each concentration

Concentration (%)	Density (kg/m <sup>3</sup> )	Viscosity (kg/m.s)	Specific Heat (J/kg.K)	Thermal Conductivity (W/m.K)
0	998.21	0.001003	4182	0.60
0.3	1007.1	0.001026	4138.8	0.66
0.5	1013.06895	0.0010426937	4110.346	0.67
1	1027.9279	0.001088556	3943.25	0.70

## 2.2 Model Characteristics

This research used computational fluid dynamics (CFD) simulation method, which in its application used ANSYS Fluid Flow Fluent software. The initial procedure applied in this study was to conduct a literature study by collecting theories related to research on nanofluid. Furthermore, the creation of fluid geometry is done using Autodesk Inventor 2020 software. Radiator design refers to an existing design. The design was included in the ANSYS software and the meshing process was carried out, then modelling on the ANSYS Fluid Flow Fluent. The design of radiator is given in Figure 1.

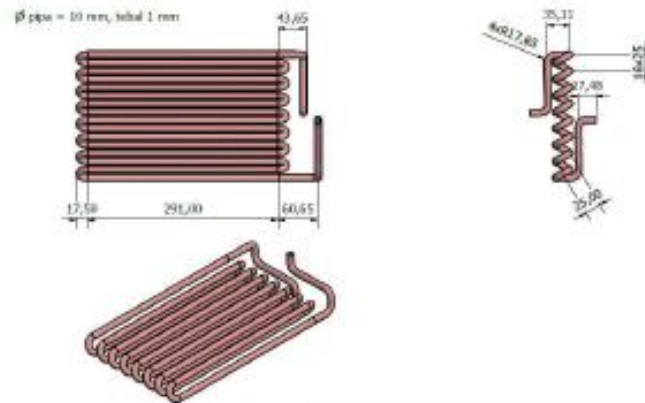

**Figure 1.** Radiator Design

*2.3 Boundary conditions*

In this work, it is assumed that inlet velocity and temperature value is 0.4 m/s and 130°C, respectively. After calculating the Reynolds number, it can be seen that the fluid flow includes a transition because the Reynolds number is more than 3000 and less than 4000, then the assumption used in viscous is k-epsilon Realizable. The value of convective heat transfer coefficient for each concentration can be seen in Table 3.

**Table 3.** Convective heat transfer coefficient

Concentration (%)	h (W/m <sup>2</sup> K)
0	118.8
0.3	198.9
0.5	212.3
1	215.6

*2.4 Numerical Method*

*2.4.1 Pre-Processing.* Geometry was converted into an Ansys Fluid Flow Fluent workbench to define the flow plane to form a fluid body as illustrated in Figure 2.

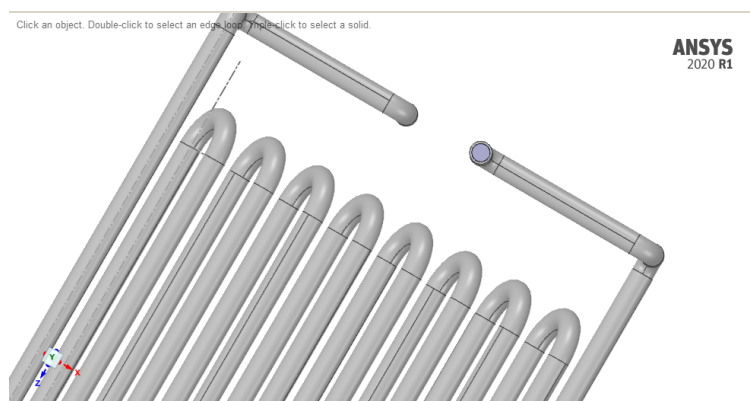

**Figure 2.** Geometry on Ansys

The next stage is the meshing process, where the meshing process can affect the accuracy value of the simulation results. The smaller meshing, the more accurate the simulation result, but it must also be adjusted to the specifications of the device used if perform calculations with a high level of accuracy. The parameters on meshing are presented in Table 4.

**Table 4.** Meshing Parameter

Parameter	Specification
Physics preference	CFD
Solver preference	Fluent
Element size	0.015 m
Smoothing	Medium
Mesh metric	Orthogonal quality
Use automatic inflation	Program controlled
Assembly mesh	None

The result of meshing with the specified parameters is shown in Figure 3. The results showed that there were 829331 nodes that indicate the number of points contained in the geometry, and 2034495 elements that indicate the number of grids in the geometry.

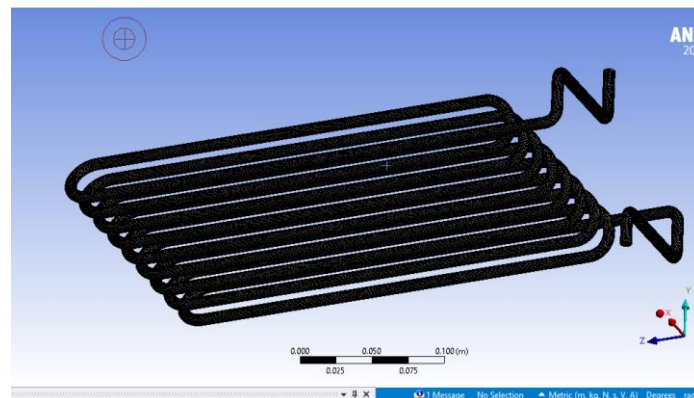

**Figure 3.** Meshing Result

**2.4.2 Solving.** The solving process aims to determine the conditions of simulation calculation. Setup in the simulation there are several assumptions including the heat transfer that occurs in the radiator pipe heat exchanger, so that the energy model is activated. After calculating the Reynolds number, it can be known that the fluid flow is in transitions regime as Reynolds number is more than 3000 and less than 4000. Based on this condition, the assumption used in viscous flow is k-epsilon Realizable because k-epsilon Realizable is widely used for complex flows with cases that tend to be simple such as heat transfer.

**2.4.3 Post Processing.** The last stage of computational fluid dynamics simulation is post processing. This stage displays the simulation results in the form of temperature contour from inlet side to outlet side, streamline velocity fluid, and fluid flow animation.



### 3. Result and Discussion

#### 3.1 Fluid Flow

The fluid flow that flows in the radiator pipe starts from the inlet to the outlet and type of flow can be known based on the calculation of the Reynolds number. Reynolds Number is a dimensionless number used to categorize fluid systems in which the effect of viscosity plays an important role in controlling the velocity or flow pattern of a fluid. Fluid flow includes laminar flow if it has the Re value of less than 2000 and if the Re value is more than 4000 then the flow includes turbulent flow [16]. The fluid flow flowing in the radiator pipe starts from the inlet up to the outlet and the type of flow can be known based on Reynolds number calculation. A transition flow is a flow regime between laminar flow and turbulent flow. Reynolds number for transition flow is between 2300 and 4000. Table 5 shows the results of Reynolds number values, while Figure 4 shows velocity streamline for each nanofluids concentration.

**Table 5.** Reynolds Number Value

Concentration (%)	Reynolds Number
0.3	3926.1
0.5	3886.34
1	3777.2

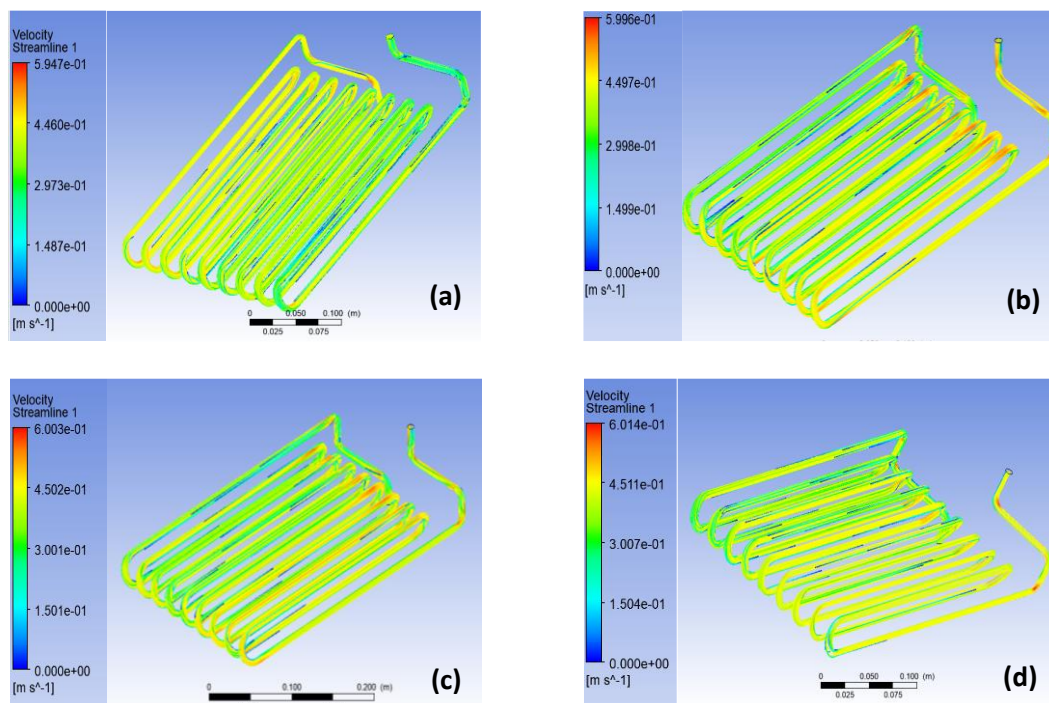

**Figure 4.** Streamline of velocity for concentration of: (a) 0% (water); (b) 0.3%; (c) 0.5%; and (d) 1%

Streamline of velocity for each concentration starts from the inlet side to the outlet side forming a flow pattern that is drawn through the lines that the fluid passes along the pipe. The 100% water has a maximum velocity of 0.5947 m/s with an average velocity of 0.411 m/s. The 0.3% concentration has a maximum velocity of 0.596 m/s with an average velocity of 0.497 m/s. The 0.5% concentration has a maximum velocity of 0.6003 m/s with an average velocity of 0.450 m/s. The 1% concentration variation has a maximum velocity of 0.6014 m/s with an average velocity of 0.451 m/s. This means that the fluid

velocity increases with increasing nanoparticle concentration. In this case, nanoparticles play a role in transporting heat energy from one place to another. This phenomenon occurs because the total energy of the moving fluid element is the sum of its internal energy with kinetic energy. There is an exchange of changes in internal energy and kinetic energy to keep the total energy of the flow constant. Based on this, the amount of internal energy will decrease by the flow of heat from the hot nanofluid to the cool environment. Consequently, the kinetic energy will increase to maintain the total energy.

### 3.2 Heat Transfer Rate and Outlet Temperature

Heat transfer is the process of energy movement due to temperature differences. The calculations we are interested in include determining the final temperature of the material and how long it will take for this material to reach that temperature. This can help inform the level of insulation required to ensure heat is not lost from the system. Lost heat is proportional to the temperature gradient (driving force or potential). The calculation result data is then exported on CFD-Post. This feature is used to display simulation results in the form of contours, streamlines, and fluid flow animations in more detail. Each variation has an inlet temperature of 130°C and has a different outlet temperature, according to the concentration of nanofluids. Figure 5 shows the contour of temperature for each nanofluids concentration.

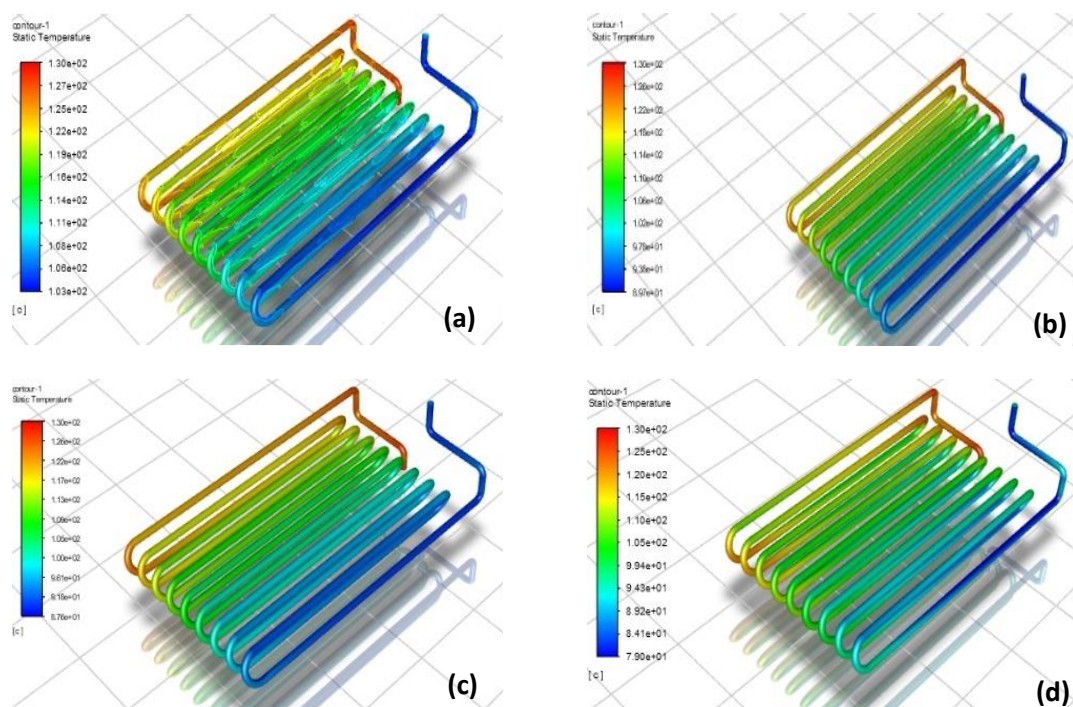
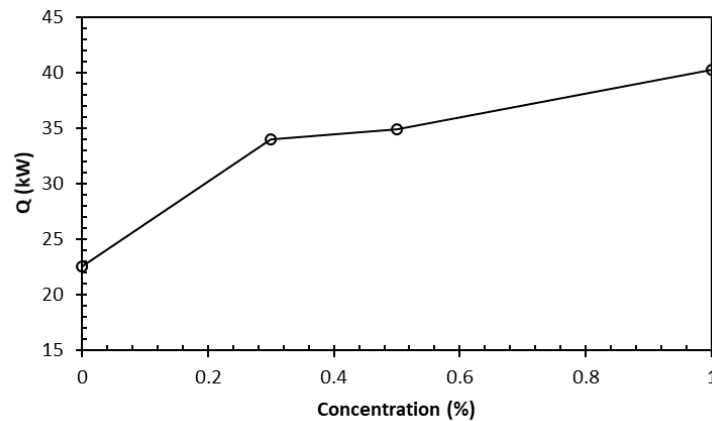

**Figure 5.** Contour of temperature along the radiator pipe for concentration of: (a) 0% (water); (b) 0.3%; (c) 0.5%; and (d) 1%

The figures above indicate the temperature contour with the inlet side depicted in red colour and the outlet side depicted in blue colour. For nanofluids with concentration of  $\text{Al}_2\text{O}_3$  of 0%, fluid temperature decreased from 130°C to 103°C. Nanofluids concentration of  $\text{Al}_2\text{O}_3$  of 0.3% was able to reduce the temperature from 130°C to 89.7°C. Furthermore, nanofluids with 0.5%  $\text{Al}_2\text{O}_3$  concentration could lower the temperature from 130°C to 87°C. Meanwhile, for nanofluids with 1%  $\text{Al}_2\text{O}_3$  concentration, the temperature drop was quite high, from 130°C to 80°C.

The simulation results showed that each concentration had a heat transfer rate varied according to the outlet temperature, as given in Figure 6. The rate of heat transfer is strongly influenced by the concentration of nanofluids.

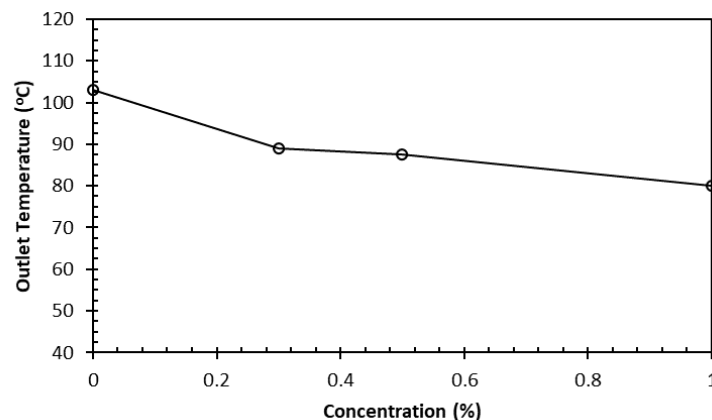



**Figure 6.** Effect of concentration of nanofluids on the heat transfer rate

The figure above shows that rate of heat transfer increased considerably with the increase of nanofluids concentration. It was found that heat transfer rate rose about 1.8 times when using a 1%  $\text{Al}_2\text{O}_3$  concentration compared to using only water as the working fluid. This could be occurred not only because of the high thermal conductivity of the coolant but also an increase in the convective heat transfer coefficient when the concentration of nanoparticles is increased [9]. As a result, the outlet temperature of the working fluid in the radiator will also change.

Figure 7 depicts the outlet temperature of the working fluid at various concentration. It could be observed that outlet temperature decreased as the increase of nanofluid concentration. As explained earlier that this phenomenon is closely related to the magnitude of the rate of heat transfer where the greater the rate of heat transfer, the faster the heat is released to the environment. Similar phenomenon has also been observed in previous studies [10,11].



**Figure 7.** Effect of concentration of nanofluids on the outlet temperature

The result showed that the optimum outlet temperature of  $80^\circ\text{C}$  was obtained at a concentration of 1% with a temperature reduction of about 38.5%. This result is very close to the generally recommended working conditions. The change of temperature is inseparable from the thermophysical properties of nanofluid at various concentration. The results of the calculations prove that the greater the thermal conductivity of nanofluid, the more it can lower the outlet temperature. The increase in concentration is also accompanied by an increase in density, viscosity, thermal conductivity and convective heat transfer coefficient. However, the specific heat will decrease as the nanofluid concentration increases.

#### 4. Conclusion

The use of nanofluid from a mixture of  $\text{Al}_2\text{O}_3$  with water as a radiator coolant has been investigated through simulation studies by using computational fluid dynamics method. This study shows the effect of nanoparticle concentration on the rate of heat transfer and the outlet temperature of the working fluid from the radiator. Under the same conditions of velocity and inlet temperature of the working fluid, increasing the concentration of nanoparticles accelerates the rate of heat transfer released to the environment. As a consequence, the temperature of the working fluid decreased along the radiator pipe. This is mainly due to the better thermal conductivity of the nanofluids compared to the base fluid of water. It was found that 1% of  $\text{Al}_2\text{O}_3$  in the nanofluid was able to reduce the coolant outlet temperature close to the generally recommended working conditions.

#### References

- [1] Zeigler B P 2017 1-How Can Modeling and Simulation Help Engineering of System of Systems? *Computational Frameworks* ed M K Traoré (Elsevier) p. 1-46
- [2] Subudhi S and Kumar A 2020 Application of Nanofluids for Radiator Cooling *Encyclopedia of Renewable and Sustainable Materials* ed S Hashmi and I A Choudhury (Elsevier) p 1-9
- [3] Sidik N A C, Yazid M N A W M and Mamat R 2017 Recent advancement of nanofluids in engine cooling system *Renewable and Sustainable Energy Reviews* **75** 137-144.
- [4] Bhanvase B A, Barai D P, Sonawane S H, Kumar N and Sonawane S S 2018 Intensified Heat Transfer Rate with the Use of Nanofluids *Handbook of Nanomaterials for Industrial Applications* ed C M Hussain (Amsterdam: Elsevier).
- [5] Sidik N A C, Yazid M N A W M and Mamat R 2015 A review on the application of nanofluids in vehicle engine cooling system *International Communications in Heat and Mass Transfer* **68** 85-90
- [6] Hafeez M B, Amin R, Nisar K S, Jamshed W, Abdel-Aty A-H and Khashan M M 2021 Heat transfer enhancement through nanofluids with applications in automobile radiator Case Studies in Thermal Engineering **27** 101192
- [7] Tryggvason G 2016 Chapter 6 - Computational Fluid Dynamics *Fluid Mechanics (Sixth Edition)* ed P K Kundu, I M Cohen and D R Dowling (Academic Press) p 227-291.
- [8] Junka R A, Daly L E and Yu X 2013 Bioreactors for evaluating cell infiltration and tissue formation in biomaterials *Characterization of Biomaterials* ed A Bandyopadhyay and S Bose (Baltham: Elsevier) p 138-181.
- [9] Elsebay M, Elbadawy I, Shedid M H and Fatouh M 2016 *Applied Mathematical Modelling* **40** 13-14
- [10] Peyghambarzadeh S M, Hashemabadi S H, Jamnani M S, and Hoseini S M 2011 *Applied Thermal Engineering* **31** 1833-1838.
- [11] Delavari V and Hashemabadi S H 2014 *Applied Thermal Engineering* **73** 380-390.
- [12] Xuan Y, Li Q and Hu W 2003 *AIChE Journal* **49** 1038-1043.
- [13] Xuan Y and Roetzel W 2000 *J. Heat Mass Transfer* **43** 3701-3707.
- [14] Park B C and Cho Y I 1998 *Exp. Heat Transf.* **11** 151-170.
- [15] Maïga S E B, Nguyen C T, Galanis N and Roy G *Superlattices and Microstructures* **35** 543-557.
- [16] Lee T S, Liao W and Low H T 2003 *International Journal for Numerical Methods in Fluids* **42** 717-74