

ISPHE 2020

Proceedings of the 5th International Seminar of Public Health and Education

Strengthening Disease Prevention through Health Education and Physical Activity for Sustainable and
Equitable Health Development

Universitas Negeri Semarang, Semarang, Indonesia

22 July 2020

EDITORS

Okta Handayani

Sri Sumartiningsih

Natalia Putriningtyas



Proceedings of the 5th International Seminar of Public Health and Education

Strengthening Disease Prevention through Health Education and Physical Activity for
Sustainable and Equitable Health Development

22 July 2020, Universitas Negeri Semarang, Semarang, Indonesia

ISPHE 2020

General Chair

RR. Sri Ratna Rahayu, Universitas Negeri Semarang, Indonesia

Technical Programme Chairs

Mahalul Azam, Universitas Negeri Semarang, Indonesia

Oktia Woro Kasmini Handayani, Universitas Negeri Semarang, Indonesia

Conference Organization

Steering Committee

Tandiyo Rahayu	Universitas Negeri Semarang
Taufiq Hidayah	Universitas Negeri Semarang
Andry Akhiruyanto	Universitas Negeri Semarang

Organizing Committee

General Chair

RR. Sri Ratna Rahayu	Universitas Negeri Semarang
----------------------	-----------------------------

General Co-Chairs

Gustiana Mega Anggita	Universitas Negeri Semarang
Lukman Fauzi	Universitas Negeri Semarang

TPC Chair and Co-Chair

Mahalul Azam	Universitas Negeri Semarang
Oktia Woro Kasmini Handayani	Universitas Negeri Semarang

Sponsorship and Exhibit Chair

Widya Hary Cahyati	Universitas Negeri Semarang
--------------------	-----------------------------

Local Chair

Mardiana	Universitas Negeri Semarang
----------	-----------------------------

Publicity & Social Media Chair

Dwi Gansar Santi Wijayanti	Universitas Negeri Semarang
----------------------------	-----------------------------

Publications Chair

Natalia Desy Putriningtyas	Universitas Negeri Semarang
----------------------------	-----------------------------

Web Chair

Efa Nugroho	Universitas Negeri Semarang
-------------	-----------------------------

Panels Chair

Mursid Tri Susilo	Universitas Negeri Semarang
-------------------	-----------------------------

Demos Chair

Galuh Nita Prameswari	Universitas Negeri Semarang
-----------------------	-----------------------------

Technical Program Committee

Mustafa Daru Affandi	Universitas Negeri Semarang
Mona Subagja	Universitas Negeri Semarang
Wiga Nurlatifa Romadhoni	Universitas Negeri Semarang

Preface

We are delighted to introduce the proceedings of the 5th International Seminar on Public Health and Education (ISPHE 2020) with the theme “Strengthening Disease Prevention through Health Education and Physical Activity for Sustainable and Equitable health Development”. This conference has brought researchers, developers and practitioners around the world.

The technical program of 5th ISPHE 2020 consisted of 103 papers, including 2 invited papers in oral presentation sessions at the main conference Panel. The conference panel were: Panel 1 – Health Education; Panel 2 – Physical Activity; Panel 3 – Applied Technologies for Health. Aside from the high quality technical paper presentations, the technical program also featured three keynote speeches. The three keynote speeches were Febrio Kacaribu, Ph.D from Ministry of Finance of Republic Indonesia; Prof. Hao-Jan Yang, B.S., M.S., Ph.D from Chung Shan Medical University, Taiwan; Prof. Dato’ Dr. Syed Mohamed Aljunid, MD., MSc(PH)., Ph.D, DLSHTM, FAMM, FPHMM, FASc from Kuwait University, Kuwait. The invited speaker was presented by Prof. Michael Yong Hwa Chia, Ph.D, PPA, FMCCY from National Institute of Education, Singapore; Assoc. Prof. Syed Abdul Shabbir, M.D, M.Sc., Ph.D from Taipei Medical University, Taiwan; Assoc. Prof. Niruwan Turbull from Mahasarakham University, Thailand; Prof. Dr. dr. Oktia Woro Kasmini Handayani, M.Kes from Universitas Negeri Semarang, Indonesia. The 5th ISPHE 2020 collaboration with Jejaring Nasional Pendidikan Kesehatan (JNPK) and also the Indonesian Public Health Association (IAKMI) and some prominent Indonesia universities in health education and sport (Malang State University, Gorontalo State University, and Manado State University). The 5th ISPHE 2020 aimed to determine the direction of health education, and physical activities related to the status of health conditions in each region; both regional and national as well as their relationship with global health trends.

Coordination with the steering chairs, Prof. Dr. Tandiyo Rahayu, M.Pd; Dr. Taufiq Hidayah, M.Kes and Andry Akhiruyanto, S.Pd., M.Pd was essential for the success of the conference. We sincerely appreciate their constant support and guidance. It was also a great pleasure to work with such an excellent organizing committee team for their hard work in organizing and supporting the conference. In particular, the Technical Program Committees, led by our TPC Co-Chairs, Dr. dr. Mahalul Azam., M.Kes and Prof. Dr. dr. Oktia Woro Kasmini Handayani, M.Kes who have completed the peer-review process of technical papers and made a high-quality technical program. We are also grateful to General Chair, Asst. Prof. RR. Sri Ratna Rahayu., M.D., M.Kes., Ph.D for her support and all the authors who submitted their papers to the 5th ISPHE 2020.

We strongly believe that 5th ISPHE 2020 provides a good forum for all researcher, developers and practitioners to discuss about health education, physical activity and applied technologies for health.

Table of Content

COVER	i
CREDIT FOR ORGANIZING	ii
PREFACE	iv
TABLE OF CONTENTS	v
ORAL AND POSTER PRESENTATIONS	
1. How to Increase the Athletes Psychological Skills?: Design and Development of Self-talk Guidance for Athletes Adiska Rani Ditya Candra, Eni Rindi Antika, Kumbul Slamet Budiyanoto, Sobihin, Hermawan	1
2. Measuring The Most Effective Spike Position in Volleyball Match Agung Wahyudi, Imam Santosa, Agus Pujiyanto	11
3. Harvard Step Test and Cooper 12 Minute Test on Improvement of Fitness Index (VO2 Max) in Basket Athletes in Pekalongan City Andung Maheswara Rakasiwi, Eko Budi Prasetyo, Irine Dwitarsari	17
4. Mental Health Issues during Covid-19 Pandemic: Directions for Future Research Anirotul Qoriah, Aftina Nurul Husna	25
5. Giving Belly Breathing Technique and Positive Affirmation of Stress and Cortisol Hormone Levels in Third Trimester Pregnant Women Annisa Septy Nurcahyani, Runjati, Sri Achadi Nugraheni	40
6. The Relationship Between Physical Fitness, Discipline and Motivation of UNNES Security Performance Aristiyanto	47
7. Peer Education: Increased Knowledge and Practice of HIV/AIDS Prevention in Female Sex Workers Arulita Ika Fibriana, Muhammad Azinar	53
8. Analysis of Lymphatic Filariasis Case Distribution for Preparing Environmental Based Elimination Strategy in Brebes Regency, Indonesia Arum Siwiendrayanti, Eram Tunggul Pawenang, Yuni Wijayanti, Widya Hary Cahyati	59
9. Policies and Strategies for Reducing Stunting through The Community Empowerment Model Bambang Budi Raharjo, Sofwan Indarjo, Efa Nugroho	68
10. Measurement of Exposure to Black Carbon and Heavy Metals on Cycle Paths in Semarang City Bambang Priyono, Agung Wahyudi, Mustafa Daru Affandi, Efa Nugroho	78
11. Modeling Associated with Picky Eating Behavior in Stunted Children Bertakalswa Hermawati, Oktia Woro Kasmini Handayani, Dhevy Fajriyatul Umma, Adinda Yustika Seftiani	83
12. Measuring Customer Satisfaction on Small-Scale Sport Event: A Case Study of The Sport Event Organizer Subject's Final Project Billy Castyana, Tandiyo Rahayu, Rumini, Dwi Gansar Santi Wijayanti, Wahyu Ragil Kurniawan	90
13. Support and Obstacles for Pregnant Woman Class in Sukoharjo, Indonesia: A Qualitative Study Burhannudin Ichsan, Harsono Salimo, Ari Probandari, Eti Poncorini Pamungkasari	97
14. Validity and Reliability Test of The Physical Exercise Movements Screening to Improve Fitness for Elderly Cerika Rismayanthi, Sugiyanto, Agus Kristiyanto, Muchsin Doewes	104
15. A Study on the Needs for Guidelines on Part-And-Whole-Based Training for Volleyball Smash Basic Technique Danang Wicaksono, Furqon Hidayatullah, Agus Kristiyanto, Sapta Kunta Purnama	112
16. Education and Reminder Software for Strengthening Anemia Prevention Program in Adolescent Girls Dian Rohmatika, Bedjo Santoso, Leny Latifah, Melyana Nurul Widyawati	118

17. The Development and Validation of Short Self-Regulation Scale (SSR) on Indonesian College Students	
Dini Tresnadiani, Argian Rizki Taufik	126
18. The Relationship of Concentration and Accuracy Against Shooting Free Throw Results in High School Students Who Follow Basketball Extracurricular	
Doni Pranata, Widiyanto	136
19. The Competitive Anxiety (Cognitive, Somatic, Affective, and Motoric) among Martial Art Athletes	
Donny Wira Yudha Kusuma, Mugiyo Hartono, Mohammad Annas, Harry Pramono, Endang Sri Hanani, Pradesta Ayu Krismonita	142
20. How Difficult Google Classroom is? A Case Study of Blended Learning Method in Physical Education	
Dony Tirta Hendriansyah, Billy Castyana, Tandiyu Rahayu, Mohammad Arif Ali, Gustiana Mega Anggita	148
21. Correlation between Teenage Nutrition Knowledges in Preventing COVID-19	
Duwi Sulistiani, Sri Ratna Rahayu, Ari Yuniastuti	155
22. Perception Survey, Mental Health and Social Media Exposure in Adolescents during The COVID-19 Pandemic	
Efa Nugroho, Alfiana Ainun Nisa, Arunia Prasya Atikassyifa	161
23. Early Detection of Toxic Profenofos Pesticide Exposure in Farmers using Simple Chemicals	
Eram Tunggul Pawenang, Hartono, Isna Qadrijati, Pranoto	171
24. Satisfaction Level of School Residents in Implementing A Child Safety System in School	
Evi Widowati, Herry Koesyanto, Sugiharto, Anik Setyo Wahyuningsih, Eko Harjanto	178
25. Classification of Arch Height Index and Arcus Pedis to The Agility	
Fajar Awang Irawan, Limpad Nurrahmad, Dhias Fajar Widya Permana	185
26. Physical Activities and Second Language Proficiencies; A Systematic Review	
Fatona Suraya, Hendi Pratama, Puput Arfiandhani	192
27. The Impact of The Implementation of Gradual Run Warming Up toward The Development of The Cardio Endurance Ability	
Fitri Rosdiana, Dikdik Zafar Sidik, Yudi Nurcahya	200
28. Development of Comprehensive General Nutrition and Nutrition Label Questionnaire	
Galuh Nita Prameswari, Arif Rahmat Kurnia, Awalukin Arianto, Tsaniatin Nahla, Mila Aliffia	206
29. Integrating Leadership into Futsal Training Program for Positive Youth Development	
Gemi Candra, Ruli Saepul Hayat, Amung Ma'mun, Nuryadi	212
30. The Differences of Elementary School Students' Interest on Traditional Games and Online Games	
Gustiana Mega Anggita, Hari Amirullah Rachman, Chang Yun-Chen, Sugiarto, Mohammad Arif Ali, Cholid Chaerudin, Adiska Rani Ditya Candra, Fuadah Nor Wiqoyatul Milla	223
31. The Effect Of Zinc Oxide Dust and Environmental Conditions of Training Ground on Lung Forced Vital Capacity Conditions of Central Java Weighthlifting Athletes	
Hadi, Mustafa Daru Affandi, Syahru Romadhoni	231
32. Athletes' Stress Determinants when Countering Fear of Failures at Their Training Center Program	
Heny Setyawati, Didik Rinan Sumekto, Nur Haziyanti, Fatona Suraya, Sungkowo, Thania Kusumaningtyas, Laksmana Pandu Pratama	238
33. Physical Growth and Motor Development of 5th Grade Students on Sub-district Pituruh Purworejo	
Hermawan Pamot Raharjo, Fera Andriyani	251
34. The Use of Oxytocin Electrostimulator Corsets as A Preventive Measures of Postpartum Bleeding Potential	
Ida Ayu Putu Dewi Adnya Suwari, Runjati, Djamaluddin Ramlan	256
35. Developing Mobile Apps Technology to Improve Student Performance in Physical Education	
Ipang Setiawan, Wahyu Ragil Kurniawan, Dwi Gansar Santi Wijayanti, Bhayu Billiandri	267

36. Effectiveness of Digital Learning in Primary Schools at COVID-19	
Jonni Siahaan, Rif'iy Qomarrullah, I Putu Eka Wiajaya Putra	281
37. Effect of Temperature on Spermatozoa Morphology	
Khori Halimah, Ari Yuniastuti, Sri Ratna Rahayu	290
38. Lecturer in the COVID-19 Pandemic Period at 30 Universities in Indonesia	
Khurotul Aini, Aisyah Kemala	296
39. Indonesian Pencak Silat Athletes Management	
Lesmana, Tatang Muhtar, Nurlan Kusmaedi, Adli Hakama	307
40. Physical Activity Trends In Millennial Generation : Kill the Body Fat	
Linda Desrianda Tamher, Giat Akbar Maulana, Mustik Fitri, Pipit Pitriani	317
41. Median Survival of Clinical Condition Improvement Factors among Patients with Type 2 Diabetes Mellitus in Semarang City, Indonesia	
Lukman Fauzi, Sri Ratna Rahayu, Anisa Wahyu Hardini, Lindra Anggorowati	325
42. Stunting Risk Factors Based on Priority Region in Indonesia: 2018 National Basic Health Survey	
Mahalul Azam, Muhamad Zakki Saefurrohimi, Syed Mohamed Aljunid	335
43. People's Clean and Healthy Behaviors during the COVID-19 Outbreak: A Case Study in DKI Jakarta Province	
Marlinda Budiningsih, Nofi Marlina Siregar, Masnur Ali	347
44. Development of Health Information System in TB Control Decision Support: Territoriality-Based Approach	
Maryani Setyowati, Noor Alis Setiyadi, Suharyo, Dwi Feri Febiyanto, Slamet Sudaryanto	355
45. Delayed Onset of Muscle Soreness and The Activation of The Immune System	
Mohammad Arif Ali, Setya Rahayu, Yang, Chia-En, Nandaru Fajar Sumirat, Bayu Pangestu, Gustiana Mega Anggita, Sugiarto, Fuadah Nor Wiqoyatul Milla	371
46. Perception of HIV/AIDS Risk Behavior among Students in Central Java Indonesia	
Muhammad Azinar, Alfiana Ainun Nisa, Furqonawati	378
47. Feeding Pattern of Under-Five Children during COVID-19 Pandemic	
Mursid Tri Susilo, Arif Rahmat Kurnia, Fitriyatun Na'imah, Muhammad Fadlil Fatihunnajah Annisa Wahyu Hidayah	388
48. Effect of Demographic, Social and Economic Factors on Adolescent Dating and Sexual Behavior in Indonesia	
Najib, Efa Nugroho	396
49. The Effect of Physical Activity on Body Composition in 9 and 10 Years Old Children	
Nawan Primasoni, Sugiyanto, Furqon Hidayatullah, Muchsin Doewes	407
50. Potential of The Red Dragon Fruit (Hylocereus polyrhizus) as An Antioxidant Exogen to Increase Catalase Giving High-Intensity Physical Activity	
Novita Sari Harahap, Nurhayati Simatupang, Awaluddin Sibuea, Suprayitno	414
51. Health Cadres in Fighting Dengue Hemorrhagic Fever	
Nur Siyam, Dyah Mahendrasari Sukendra, Yunita Dyah Pustita Santik	421
52. Rice Bran for Diabetes Mellitus Prevention and Snackification	
Oktia Woro Kasmini Handayani, Siti Fathonah, Arif Rahmat Kurnia	428
53. Basic Movement of The Split Leap Rhythmic Gymnastic	
Ranu Baskora Aji Putra, Tommy Soenyoto, Agus Darmawan, Roas Irsyada	434
54. Developing Assessment Model of a Tennis Forehand Stroke as Biomechanics Movement Perspective	
Ricko Irawan, Agus Raharjo, Lulu April Farida	443
55. The Correlation between Wind Direction and Wind Speed with The Landing Accuracy Result on Paragliding Athletes	
Sahri, Nanang Indardi, Nur Amin	449
56. Exercising in Urban Environment during COVID-19 Pandemic	

Said Junaidi	455
57. Effectiveness Test of Tools (Wire Steel) toward Forwarding Somersault Skills	
Sani Gunawan, Fegie Rizkia Mulyana, Ridwan Gumilar	465
58. The Achievement of Physical Education Learning Objectives during Covid-19 Pandemic	
Septian Williyanto	473
59. Physical Exercises cause Muscle Damage and Potential Treatments to Increase Range of Motion	
Setya Rahayu, Mohammad Arif Ali, Natsuangkorn Kongchulagul, Ebenezer Silaban, Didit Prakosa Adi Nugroho, Muchamad Sadhali, Sugiarto, Gustiana Mega Anggita	481
60. The Potential of Red Beetroot Powder as an Athlete Supplementation According to Its Organoleptic Properties	
Setya Rahayu, Natalia Desy Putriningtyas, Tandiyo Rahayu, Mahalul Azam, Eka Yuli Astuti	488
61. Sports Talents Selection of Early-Age Athletes in Central Java using Natural and Scientific Methods	
Soedjatmiko, Wahadi	494
62. Community Characteristics in COVID-19 Preventive Precautions	
Sri Ratna Rahayu, Intan Zainafree, Aufiena Nur Ayu Merzistya, Tika Dwi Cahyani	504
63. The Application of FIFA 11+ Injury Prevention Program on Youth Football Club in Semarang City	
Sri Sumartiningsih, Sugiharto, Jens Eiberger, Anggit Risdiyanto, Ashril Yusof	514
64. Socio-Demographic Characteristics Associated with Loss To Follow-up of Antiretroviral Therapy Among HIV and AIDS Patients in Semarang City, Central Java Province: A Case Control Study	
Sutini, Widya Hary Cahyati, Sri Ratna Rahayu, Muchlis Achsan Udji Sofro, Nur Fahanah, Setyo Pramudo, Farid Agushybana, Selamet Hidayat, Tuti Susilowati, Slamet Riyadi	520
65. Student's Compliance In Doing Physical Activities during COVID-19 Pandemic	
Sutopo Patriajati, Arnia Dian Kusuma Devi	530
66. Blended Learning as The New Innovation in Physical Education Class	
Tandiyo Rahayu, Mohammad Arif Ali, Katrin Koenen, Andrea Blume, Gustiana Mega Anggita, Billy Castyana, Hermawan Pamot Raharjo	540
67. Digital Media Habits among Parent of Preschool Child Aged 2-6 Years in Semarang City, Indonesia	
Tandiyo Rahayu, Widya Hary Cahyati, Lukman Fauzi, Michael Yong Hwa Chia, Hendri Hariyanto, Anisa Wahyu Hardini, Farida Nurjanati Hardanis	546
68. The Effect of Cardio and Tabata Exercises on Decreasing Body Fat, Weight and Increasing Physical Fitness	
Taufikkurrachman, Amy Nilam Wardathi, Afif Rusdiawan, Reno Siska Sari	553
69. Transparency Level Profile of Sports Organizations in Central Java, Indonesia	
Tri Rustiadi, Billy Castyana, Dwi Tiga Putri, Heny Setyawati	570
70. Development Model For Android-Based Bullet-Bulleted Obraine Styles	
Ucok Hasian Refiater, James Tangkudung, Hernawan, Firmansayah Dlish	577
71. Improving Prime Skills of Artistic Swimming with Mental Training through Land Drill	
Wasti Danardani, Soegiyanto KS, Hari Setijono, Sulaiman	586
72. Sociometry of a Women Handball Team	
Wiga Nurlatifa Romadhoni, Nasuka Nasuka, Erwin Nizar Priambodo	596
73. Analysis of Physicochemical and Sensory Quality of Chia Seeds Sport Energy Gel (<i>Salvia hispanica</i>, L) during Storage	
Yanesti Nuravianda Lestari, Eko Farida, Nur Fauzi, Fadjrul Falah Fikri	603

How to Increase the Athletes Psychological Skills?: Design and Development of Self-talk Guidance for Athletes

Adiska Rani Ditya Candra¹, Eni Rindi Antika², Kumbul Slamet Budiyanto³, Sobihin⁴,
Hermawan⁵

{adiska_rani@mail.unnes.ac.id¹, rindi@mail.unnes.ac.id², kumbulkang-
dipati@mail.unnes.ac.id³}

Universitas Negeri Semarang, Semarang, Indonesia^{1,2,3,4,5}

Abstract. The study aims to develop and perform validation stages toward the "Self-Talk Guidance" book for athletes. This guide book focused on the steps that must be taken to apply the psychological intervention techniques to self-talk in various situations during training or competition. The target of developing this book is professional athletes who will later be used as research subject. The study uses the ADDIE (Analysis, Design, Development, Implementation, Evaluation) Research and Development model. This research involves experts in fulfilling expert judgment to validate the book developed and to create products that can be used for the testing process directly to check the effectiveness of the product. The results of research analysis obtained by the product have excellent criteria on the results of expert judgment. The conclusion of this research is that the product is feasible to use and ready for product trials and product effectiveness tests.

Keywords: Athlete, Psychological Intervention Techniques, Self-talk Guidance.

1 Introduction

Increased interest in psychology in the field of sports is seen in various types of research that links the psychological relationship in the world of sports. Several researchers Birrer & Morgan; Sindik *et al*; MacNamara *et al* examines the interrelationship of psychological skills, as well as the identification of talents on the athlete's performance which provides a strong empirical basis on the importance of psychological characteristics in facilitating athlete development in sports [1,2,3]. A developed mindset that provides a solid foundation for intervention and psychological factors is central to many highly beneficial talent development environments [4]. Other studies

have shown that embedding psychological skills into a development environment ensures that prospective elite athletes use and develop appropriate skills to overcome current and future challenges in their main performance [3].

Psychological skills have an impact on the physical performance of athletes in achieving peak performance. Weinberg and Gould also stated that most coaches think that winning in a match depends on 50% psychological preparation [5]. Therefore, most athletes do mental training as an additional effort to supplement physical training. Thelwell mentions that mental exercise interventions are used to facilitate specific positive outcomes [6]. Thelwell's research results compared several psychological interventions used such as imagery, self-talk, relaxation on athlete performance. It was found that psychological skills can affect performance in different ways.

Psychological skills can be trained and developed through Psychological Skills Training (PST). The importance of psychological skills training (PST) has been recognized and athletes using psychological intervention strategies have also increased [1]. Although interest has increased, several things need attention. First, researchers have recently given reasons for the choice of skills in interventions. Second, many focus on measuring interventions on performance outcomes and the third on the extent to which psychological skills affect performance in the overall competition [6]. Concerning the measurement of psychological interventions, various studies conducted by M. Behnke *et al*; Sindik *et al*;; Zourbanos *et al* which includes measurements, inventory development and psychological questionnaires [7,2,8].

Some mental training that has been validated include imagery techniques [9], self-talk techniques [10], and pre-work routines [11]. And in this discussion, it refers to the self-talk technique. The sports psychology literature states that self-talk techniques have progressively increased. The study of self-talk by sharing research designs and tasks fully supports that self-talk can be an effective cognitive intervention strategy for performance improvement [12] [13]. The meta-analytic study of self-talk also concludes that the effect of self-talk is recommended and suggested as a strategy to facilitate performance improvement exercises and to be a recommendation for new research directions [14].

However, as many studies have revealed the effect of self-talk on performance, there is no list of materials used as an intervention strategy and its structure has not been established [7]. This refers to the scarcity of research on the structure of the use of strategies for self-talk interventions both procedures and steps to use self-talk. A lack of understanding of the situation that has to do with how the results of applying self-talk to achieve success are impossible [15]. Paying attention to the evidence relating to the effectiveness of self-talk and research that focuses on measuring the level of intervention strategies for improving performance and enhancing psychological skills must be accompanied by how the stages are carried out.

Some recommendations referred to the use of self-talk in enhancing psychological skills require specific guidance for athletes which contains steps for the use of self-talk intervention strategies in practice and competition. This purpose of this research will prepare the design and development that will be used as a basis for further research on the development of the Self-talk Guidance book that can be used by the athletes.

2 Methods

This research is RnD research using ADDIE model. The purpose of this research is intended to produce designs and develop products that are ready to be tested. The product developed is a guide book on Self-talk Intervention Strategies that can be practiced by athletes and namely "Self-talk Guidance".

Development procedures using the ADDIE model are often used to describe systematic approaches to instructional models and center on individual learning and performance. The ADDIE model by M Branch [16] and clarified by Molenda (2003) in Shelton [17] consists of five phases namely Analyze, Design, Develop, Implement and Evaluate.

1. Analyze contains an analysis of problem identification and product needs analysis
2. The design contains the formulation of the method, the content of the material and the determination of strategies in making the Self-talk guidebook product based on the problem being examined
3. Develop, the stage of product creation and development that results in a self-talk guidance book.
4. Implement, prepare athletes and coaches with research areas that have been conditioned for the implementation of the use of products
5. Evaluated, to evaluate the system development method used and see the results of research.

Table 1. Rating range for Expert Judgement

Scale	Value Range	Criteria
5	$X > 4,21$	Excelent
4	$3,40 < X \leq 4,21$	Very good
3	$2,60 < X \leq 3,40$	Good
2	$1,79 < X \leq 2,60$	Fair
1	$X \leq 1,79$	Poor

Data analysis techniques to determine product validity using descriptive percentages with the following formula:

$$P = \frac{\sum x_i}{\sum x_j} \times 100\%$$

Calculation of the percentage results will provide the conclusions presented in the percentage classification as follows:

Table 2. Percentage Classification of Product Feasibility Test

Procentage	Clasifie	Justify
75 – 100 %	Very good	Very feasible to use
50 – 75 %	Good	Proper to use
25 – 50 %	Fair	Revised
0 – 25 %	Poor	Not feasible to use

3 Results and discussions

3.1 Results

A Guidebook on the use of a self-talk intervention strategy called “Self-talk Guidance“ has been developed with ADDIE development research procedures. The stages that have been carried out so far include Analysis, Design, and Develop. The results of this research can be described as follows:

a) Analysis

The analysis phase is obtained based on needs analysis and identification of problems that exist in athletes. Furthermore, this analysis phase also looks for gaps or differences between psychological skills training and athlete performance in training and competition. Information was obtained based on the results of interviews with the Coaches, this time represented by the Central Java softball trainer and the chairman of the KONI in Central Java. The results of the analysis and problems identification formulate the main problems such as (1) the coaches states that athletes in a state of urgency often feel unsteady and experience some problems with psychological factors such as anxiety, discomfort, decreased concentration which will have an impact on the results of the throw or punch during competition, (2) the coaches feels there is a need for various exercises combined with psychological skills training, (3) during the training session the athlete also does not understand how to improve psychological skills through psychological intervention strategies.

Based on the results of the analysis obtained that athletes need to get mental training ibased on athlete needs. There is no structured mental training program that makes researchers have a plan and think of strategies so that athletes can have psychological skills with exercises that can be done individually both with coaches and without coaches. The researcher formulated a strategy to create an intervention strategy guide book, Self-talk that would assist athletes in controlling themselves in improving performance related to psychological skills.

b) Design

The formulation of ideas regarding the development of a self-talk guidance for athletes will be designed at this stage. The design of the content of the material from the book involves colleagues who are engaged in guidance and counseling. This is designed so that the contents of the material do not come out of the context of self-talk guides that are designed for athletes. The design of the book is packed with attention to the breadth of the scope of the material with a calculated theme.

The design of the contents of the book consists of several parts or divided into chapters to make it easier for athletes to understand the contents of the manual. At this stage the researcher also looks for sources both from books or journal articles to complete the material contents Not only preparing materials for the design phase also formulates a questionnaire that will be used for assessment of the feasibility of the book by the expert, and a questionnaire that will be given to the coaches and also the athletes

c) Develop

At this stage, the design formulation will be developed. scope of the content of several chapters will be made in full and ready to be made into a book as a whole.

After that, the book validation proses to check whether the book that has been made is feasible for use or not and whether there are revisions that must be made. Validation in expert judgment will be conducted by 2 experts, one of them is a sport psychologist and the other one is guidance and counseling expert.

The initial draft of the development of the Self-talk Guidance book is divided into sections or chapters including:

Chapter 1 Contains instructions for understanding and reading the guidebook.



Fig. 1. Cover book of self-talk guidance

Chapter 2 Contains definitions and general descriptions of sports psychology, as well as psychology techniques in sports



Fig. 2. Content of chapter 2

Chapter 3 Contains a description of the definition of self-talk and the types of self-talk. In the sport psychology self-talk is divided into motivational self-talk and instructional self-talk. In this case a lot of research related to the comparison of these two types of self-talk. In the Self-talk Guidance book, Self-talk is divided into 4 types proposed by Jones (2003; 2005) namely (1) Goal Setting Self-talk; (2) Cooling and Calming Self-talk; (3) Self-talk Coaching; (4) Corrective Self-talk.



Fig. 3 Content of chapter 3 and instructional questions that must be answered and conducted by athletes

Chapter 4. This chapter contains a strategy of implementing self-talk in which this chapter presents illustrations of cases that are familiar with sharing the type of self-talk. For example when athletes do self-talk but direct towards negative self-talk, there are directions and ways for athletes to be able to apply self-talk correctly so that when athletes speak that make them lose concentration, lack of confidence, do not feel the spirit can be changed into positive self-talk that can increase arousal, reduce anxiety, increase self-confidence and concentration which will directly affect the athlete's mindset and affect the athlete's performance. And in each session, a type of case is given for athletes who will apply self-talk to practice on their own according to the stages of each type of self-talk.

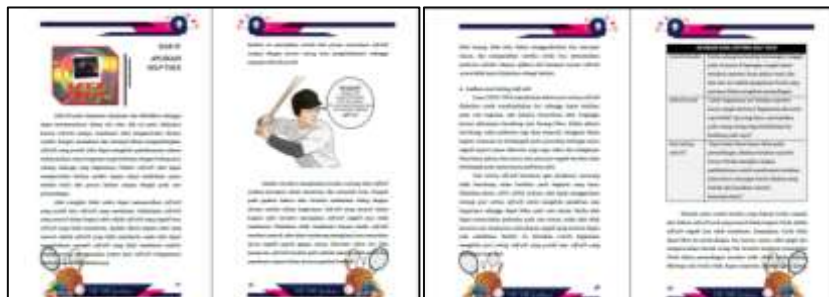

Fig. 4. Content of chapter 4 and illustrate in each type of self-talk

Based on the results of expert judgment by the expert, the following data were obtained

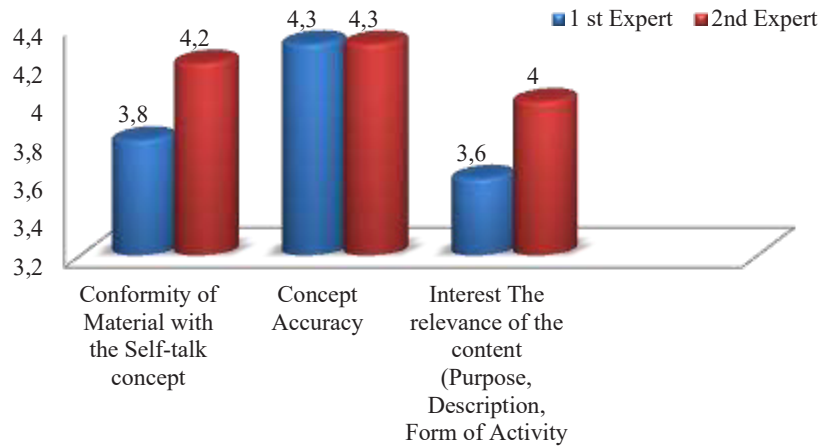

Fig. 5. Diagram mean result expert judgment of self-talk guidance

Based on the table above, it is known that the result of the first expert was obtained a mean of 3.9 and is categorized very good while the second expert with a mean of 4.2 with an excellent category. Based on the results of the first expert discussion said that the book can help the athletes based on research, but there need to be revisions such as add research results to strengthen why self-talk is effective to use, give illustrations of world elite athletes who use self-talk. While the second expert reveals the whole book can help athletes to improve their psychological skills. What needs to be added is the concept of sports psychology is not only about psychological techniques, but also added psychological aspects in sports. After discussing the aspects of sports psychology it is more obvious to enter into a psychological intervention strategy where this strategy is intended to improve the psychological aspects of athletes' psychological skills.

The results of expert judgment will be calculated product feasibility test. Product feasibility test results obtained from the first expert is 78 % and form the second expert is 83,64%. According to data on the results of the product feasibility test from the two experts stated that the product is feasible to use. That means the product is ready to be continued in the next phase, which is the implementation phase and ready to be used as a trial product.

3.2 Discussions

Development using the ADDIE model is mostly used as a basis for making instructional assignments for individual learning in a learning environment. The appli-

cation of the ADDIE concept is designed for a supportive system to facilitate the complexity of intentional learning by addressing variations. In this study using ADDIE because R. Branch explains that ADDIE can be used depending on the context in which ADDIE is applied. The Center for Instructional Design on individual learning has a direct and long-term learning phase. ADDIE considers the process of making products most effective because ADDIE is a process that functions as a guide to complicated work discussions that are appropriate for developing educational products and other learning resources [16].

The same thing as this self-talk implementation manual is because the book is focused on athletes to learn various intervention strategies as a training process to improve psychological skills. The development of the Self-talk guidance book is designed so that athletes can apply self-talk techniques with various types of self-talk following the situation being faced both during practice and during training. That is the reason researchers use the ADDIE concept as a development model for this book.

Based on the results of studies that have been submitted by researchers that the Self-talk Guidance book is ready to be tested, then why is the Self-talk guide book? Research related to self-talk in sports has been tested and has its limitations. The effectiveness of the use of self-talk has shown significant results such as research by Antonis Hatzigeorgiadis *et al* (2017) who examined the effect of self-talk on attention from the results of this study that self-talk is an intervention strategy that can improve performance in sports. Self-talk has a beneficial effect on attention. Recommendations from this study are important for developing theories and comprehensive information to provide self-talk practice [18]. A similar study by Yu-kai Chang *et al* (2016) which compared motivational self-talk and instructional self-talk from the research results concluded that both experimental groups had better results on the performance of softball athletes than the control group and the recommendations of this study motivational self-talk have better results than instructional self-talk [19].

Findings related to self-talk that support in facilitating learning and improving the performance of task implementation need to have a strategy and a plan that must be strongly encouraged. Regardless of any purpose, if the research does not yet support all the functions that can be carried out by self-talk, but when self-talk is designed well and carefully according to individual needs, this self-talk will have a significant affect such as increasing attention, regulating cognitive reactions and emotions, increase self-confidence, trigger automatic performance, and increase motivation [20].

Based on previous studies results, an outline the implementation of self-talk will greatly benefit if the application of self-talk is well designed and carefully adjusted to the needs. As well as providing appropriate information on implementing self-talk intervention strategies. The development of the Guidance Self-talk was indeed designed and made so that athletes could obviously know the self-talk intervention strategy properly and correctly. In addition, athletes can learn to use self-talk either accompanied by a coach or not and use self-talk in various situations both during training and competition.

4 Conclusions

This study aims to design and develop a book on the application of psychological self-talk intervention strategies, namely self-talk guidance intended for athletes. This study uses the concept of developing ADDIE models that are focused on athlete learning can be practice self-talk intervention techniques/strategies in a variety of situations. The results of the study indicate that the development of the book "Self-talk Guidance" is appropriate to be used and continued at the implementation stage of product trials. Self-talk is a psychological intervention strategy that is widely used and recommended by researchers to improve psychology skills for athletes. The design of giving self-talk intervention strategies needs to be carefully considered according to the needs of athletes so that self-talk can provide significant benefits.

Acknowledgments

This study would not have been possible without the help that I received from all of my friends, colleagues. To begin with, we would like to acknowledge the honorable both of the experts who helped this study running well and give the suggestions and best recommendation for best quality the Sself-talk Guidance. Expert are in sport Psychology is Mr. Donny Wira Yudha P.hD and from Guidance and Counseling is Mr. Mulawarman P.hD. Next acknowledge for my partners who have contributed in developing the contents and structure of Self-talk Guidance book, Eni Rindi Antika.. And all research members who have contributed to run this research. This study was granted by Faculty of Sports Science, Universitas Negeri Semarang (DIPA FIK UNNES Tahun Anggaran 2020).

References

- [1] Birrer D, Morgan G. Psychological skills training as a way to enhance an athlete's performance in high-intensity sports. *Scand J Med Sci Sport*. 2010;20(SUPPL. 2):78–87.
- [2] Sindik J, Novokmet N, Havas-Augustin D. The application of psychological skills inventory for sports at Croatian coaches and recreational table tennis players. *Sport Sci* 6. 2013;1(2014):54–60.
- [3] MacNamara Á, Collins D. Profiling, exploiting, and countering psychological characteristics in talent identification and development. *Sport Psychol*. 2015;29(1):73–81.
- [4] MT Elferink-Gemser, C Visscher. Who are the superstars of tomorrow? Talent development in Dutch Soccer. In: *Talent identification and development in sport*. London: Routledge; 2013. p. 115–25.
- [5] Weinberg RS, Daniel G. *Foundation of Sport and Exercise Psychology*. Sixth Ed. 2015.
- [6] Thelwell R, Weston N, Greenlees I. Examining the use of psychological skills throughout soccer performance. *J Sport Behav*. 2010;33(1):109-127.
- [7] Behnke M, Tomczak M, Kaczmarek LD, Komar M, Gracz J. The Sport Mental Training Questionnaire: Development and Validation. *Curr Psychol*. 2019;38(2).
- [8] Zourbanos N, Hatzigeorgiadis A, Chroni S, Theodorakis Y, Papaioannou A. Automatic self-talk questionnaire for sports (ASTQS): Development and preliminary validation of a measure identifying the structure of athletes' self-talk. *Sport Psychol*. 2009;23(2):233–51.
- [9] Gentili R, Han CE, Schweighofer N, Papaxanthis C. Motor learning without doing: Trial-

- by-trial improvement in motor performance during mental training. *J Neurophysiol.* 2010;104(2):774–83.
- [10] Hatzigeorgiadis A, Galanis E, Zourbanos N, Theodorakis Y. Self-talk and Competitive Sport Performance. *J Appl Sport Psychol.* 2014;26(1):82–95.
- [11] Velentzas K, Heinen T, Schack T. Routine integration strategies and their effects on volleyball serve performance and players' movement mental representation. *J Appl Sport Psychol.* 2011;23(2):209–22.
- [12] Hardy J, Gammage K, Hall C. A descriptive study of athlete self-talk. *Sport Psychol.* 2001;15(3):306–18.
- [13] Hatzigeorgiadis A, Zourbanos N, Goltsios C, Theodorakis Y. Investigating the functions of self-talk: The effects of motivational self-talk on self-efficacy and performance in young tennis players. *Sport Psychol.* 2008;22(4):458–71.
- [14] Hatzigeorgiadis A, Zourbanos N, Galanis E, Theodorakis Y. Self-talk and sports performance: A meta-analysis. *Perspect Psychol Sci.* 2011;6(4):348–56.
- [15] Latinjak A, de las Heras B, Sacot A, Fernandez D, Robinson D, Lane A. Effects of Reflection to Improve Goal-Directed Self-Talk on Endurance Performance. *Sports.* 2018;6(2):55.
- [16] Branch RM. *Instructional Design. Instructional Design : The ADDIE Approach.* New York Dordrecht Heidelberg London: springer; 1978. 1–190 p.
- [17] Shelton K, Saltsman G. Applying the ADDIE model to online instruction. *Adapt Inf Commun Technol Eff Educ.* 2007;(October 2004):41–58.
- [18] Hatzigeorgiadis A, Galanis E. Self-talk effectiveness and attention. *Curr Opin Psychol [Internet].* 2017;16(d):138–42.
- [19] Chang YK, Ho LA, Lu FJH, Ou CC, Song TF, Gill DL. Self-talk and softball performance: The role of self-talk nature, motor task characteristics, and self-efficacy in novice softball players. *Psychol Sport Exerc.* 2014;15(1):139–45.
- [20] Theodorakis Y, Hatzigeorgiadis A, Zourbanos N. *Cognitions: Self-Talk and Performance.* 2012. 1–42 p.

Measuring The Most Effective Spike Position in Volleyball Match

Agung Wahyudi¹, Imam Santosa², Agus Pujianto³
 {agungwahyudi@mail.unnes.ac.id¹, santosoimam29@mail.unnes.ac.id², gusp-
 jianto.73@mail.unnes.ac.id³}

Universitas Negeri Semarang, Semarang, Indonesia^{1,2,3}

Abstract. This research was conducted to find out which position is the most effective in order to score points faster. A descriptive quantitative research was conducted with survey and observation methods at volleyball matches participated by 24 elite Indonesian athletes at the 2019 ASEAN School Games. Observation and survey were made at UIN Walisongo Semarang Sport Complex on 19-23 July 2019 by observing aspects of attacking positions and the effectiveness of the attack. Data were analyzed using descriptive method to find out which spike position was the most effective. Data showed that the middle position is the most effective position to spike, both for the men's team (78.3%) and women's team (67.31%). Based on the result, middle position is able to make the attacking team Setter direct the ball using the quick technique. The middle position also can make Setter bounce the ball higher and unreachable by the blocker defense team.

Keywords: children volleyball, spike position, ASEAN School Games

1 Introduction

Volleyball nowadays, is very popular in various Southeast Asian countries. This can be seen when volleyball is a sport that is competed in the SEA Games and at the student level, such as the ASEAN School Games. In Indonesia, volleyball, these days, has been widely played by the public. This can be seen by the increasing number of volleyball clubs being founded and volleyball matches being conducted at the moment. During the matches and coaching conducted by the club, they have managed to score talented athletes in various regions in Indonesia. Even the Men's Indonesia Volleyball Team was able to become the runner-up since the ASEAN School Games was first held and the Women's Team managed to win first place in 2013-2014. However, the success of an athlete is still determined by the ability and good technique. In volleyball, athletes must have motor skills and the ability to jump. In addition, they also have to hone power, agility, flexibility, and good reaction speed [1]. One technique that is a determining factor in volleyball is Spike. Because this technique is an important part of being able to win a volleyball match [2]. In addition to a capable

technique, Spiker is also required to have a high posture so he can easily carry out attacks to the opponent's area.

The spike technique in volleyball is not an easy technique to do. The technique has four phases that must be done, namely approach phase, arm cocking phase, acceleration phase, and follow through phase [3]. In addition, the movement of the spike is also influenced by several factors, including the height of the ball when in contact with the player's hand, the tempo of the attack, etc [4]. Therefore, this technique must often be trained and carried out to get maximum results, even a professional volleyball athlete spikes 40,000 times a year [5]. However, mastering the technique alone is not enough to guarantee victory in volleyball matches. Players must know which position is the most effective in making spikes so they can immediately score points.

Spike technique can be performed from various positions, including positions four, three, two, and rear position (attack line). From some of these positions, a coach must pay attention to the level of difficulty and the most effective position to generate numbers so that he can arrange teams based on the types of players correctly. However, not all coaches understand the importance of using skills or tactics in sports matches. In fact, a match that does not have a directed tactic can affect the final outcome of the game and will psychologically affect the mental condition of athletes and team cohesiveness on the field [6,7].

Volleyball as a sport played by six people in a team has several techniques, namely serves, passing, spike, and blocking [8]. When the team has 25 points, the team is declared to win the round. As a team sport, volleyball requires good teamwork so they can work well together. This sport also requires good technical mastery, good physical condition, expertise in managing tactics, and strong mentality to bring maximum achievement [9]. One of the most important techniques in determining victory is a spike because this technique serves to get points quickly. In this technique, there are three effective methods for doing this, including high bait, Tip Technique (slow spike), and sharp spike [10]. Besides, in volleyball matches, knowledge of the court zone is important to learn because the different abilities and actions that must be taken when the team competes are very dependent on the athlete's position in the court [11]. Therefore, the trainer must be able to train various variations and choices of attacks that cannot be predicted because this will be fundamental to the pattern of attacks. By learning the pattern of the game and the possibilities of situations that can occur during a match, this also helps prepare the athlete when competing.

Spike is a technique that can make points in volleyball is an essential skill [2]. Spike movement must be able to make the ball pass over the net, especially if the technique can produce sharp blows to the opponent's area so that his attacks cannot be blocked [12]. There are several stages that must be done so that athletes can make spike movements, consisting of footwork steps, repulsion, release the ball in the air, and landing. In addition, athletes can also practice this technique with several variations of exercises, such as simple open spike exercises, spike exercises with the help of passing, and semi-spike exercises [13]. However, at the beginning of practicing the spike movement, many mistakes that often occur include improper body position, the imposition of the ball with the arm, and swinging the arm that is still wrong [14].

To be able to create spike movements that can make points quickly, the trainer needs to know that there are several different types of athletes in choosing positions that can support the quality of the movement. If the athlete is the Ace Spike type, he

will more often use high passes when spiking. While athletes with the Quicker type, they feed shorter or with a fast ball and the all-round athlete can use more mixed movements [15]. Spikes have a variety of spike results in accordance with the direction of the ball, such as cross-court spikes and straight spikes. In addition, based on the road curve, the results of the spike movement have several differences, namely strong spike, lob spike, and drive spike. Spike movements can also be divided based on the height of the ball just before the athlete makes an attack, namely open spike, semi spike, and quick spike [16].

From those statements, it can be seen how important it is to understand the tactics and strategy in volleyball, especially the position in spike movements. In fact, the spike movement is the fastest movement to get points, but there is no research on which positions are most effective in spike movements. Though research on matches and tactics in volleyball matches is very important. This can help to optimize the training process by developing strategies and concepts to improve the ability of athletes and teams [7]. Therefore, this research was conducted to find out which position is the most effective in order to score points faster.

2 Methods

This is a descriptive quantitative research with survey and observation methods conducted at volleyball matches participated by 24 elite Indonesian athletes at the 2019 ASEAN School Games. Observations were made at UIN Walisongo Semarang Sport Complex on 19-23 July 2019 by observing aspects of attacking positions and the effectiveness of the attack. Data were analyzed using descriptive percentages method so that they could find out which spike position was the most effective with the following criteria:

Tabel 1. Spike Successful Criteria

Percentage	Criteria
76% - 100%	Very Good
51% - 75%	Good
26% - 50%	Average
0% - 25%	Poor

3 Results and discussions

During the observation, the men's team made 259 spikes (blue bar) and the women's team made 314 spikes (orange bars). When viewed in more detail, the men's team mostly made 103 spike movements in the front position and only made 49 spike movements in the back position. This is due to the men's team setters more often directing the ball to the front position using the drive ball. This direction of the ball can

make it easier for the spiker to strike back because in volleyball matches, the opposing team puts set-upper in the middle to block. However, usually the set-upper has a short height when compared to speakers who tend to have tall bodies so as to make the attacking team superior.

While the women's team made 144 spikes in the front position and only made 48 spikes in the back attack position. This is due to the Setter on the women's team more often carrying out attacks to provide an opportunity for Spiker who master the Open Spike technique to attack by relying on power. This attack becomes difficult to block by Middle-Blocker opponents so that Spiker is easier to get points.

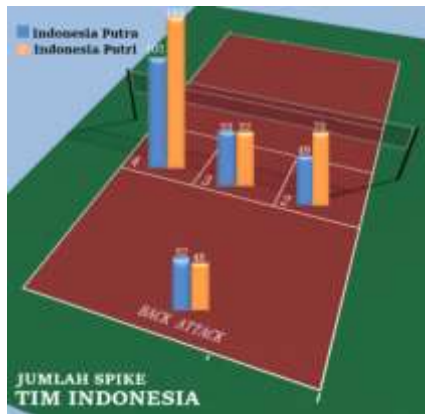

Fig 1. Number of Spike is performed by Athletes

However, if seen from the effectiveness of the spike movement position in getting points, then the middle position is the most effective position to spike, both for the men's team and women's team. In addition, the most common spike movement in the middle position is the Quick Spike.

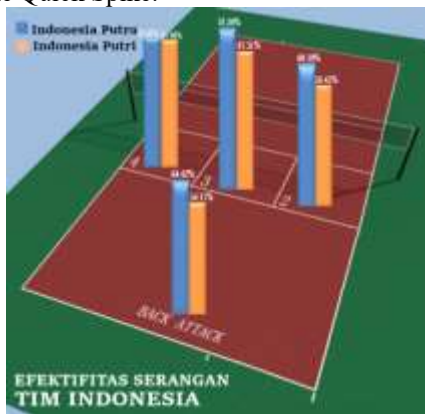

Fig 2. Percentage of Spike Position's Effectiveness

When talking about strategy in volleyball matches, there are two types of attacks that can be done, namely side-out attacks or counterattacks. Side-out attacks have better effectiveness because it is more balanced to keep attacking during matches. However, with the help of a counterattack, the team also received additional benefits to win the match [17].

The middle position is the most effective because the attacking team Setter can direct the ball using the Quick technique. This technique can create a pattern of attack with a quick type so that it can outwit the opponent. This is also supported by Palao and Ahrabi-Fard's statement that the success of a team to win the match is to put the setter and spiker in the middle position. When Setter is in the middle position with Spiker, he/she has four attack options. Although this is not the only factor in determining the success of the attack, but by doing so, the team has the balance to carry out the second attack. This balance occurs because the Setter is closer to the Spiker so it can counterattack quickly [11]. In addition, the middle position can make Setter create a ball that bounced high and out of the reach of the Blocker of the defense team so that Spiker can carry out powerful and sharp attacks. Such attacks will be more effective than relying on rally points that have the possibility of failing more [18]. Besides, training the team to carry out attacks in a balanced position will help athletes to overcome positions that are not ideal for attacking.

4 Conclusion

Based on the results and discussion, it can be concluded that the middle position is the most effective position in spike movements in order to get points faster. It is also an input for the trainer to give more practice portions to techniques that are useful for conducting attacks in the middle position. Later, further research can be done by looking at the weakest attack areas during volleyball matches.

References

- [1] Lehnert, M., Sigmund, M., Lipinska, P., Vařeková, R., Hroch, M., Xaverová, Z., & Zmijewski, P. Training-induced changes in physical performance can be achieved without body mass reduction after eight week of strength and injury prevention oriented programme in volleyball female players. *Biol. Sport.* 2017; 34(2):205.
- [2] Castro, J., & Mesquita, I. . Implications of offensive spacing in elite male volleyball attack characteristics. *PJSS.* 2018; 8(1):114-125.
- [3] Kugler, A., Krüger-Franke, M., Reininger, S., Trouillier, H. H., & Rosemeyer, B. Muscular imbalance and shoulder pain in volleyball attackers. *Br. J. Sports Med.* 1996; 30(3):256-259.
- [4] García-de-Alcaraz, A., Ortega, E., & Palao, J. M.. Effect of age group on male volleyball players' technical-tactical performance profile for the spike. *Int. J. Perf. Anal. Spor.* 2015; 15(2):668-686.
- [5] Reeser, J. C., Fleisig, G. S., Bolt, B., & Ruan, M. Upper limb biomechanics during the volleyball serve and spike. *Sports Health.* 2010; 2(5):368-374.
- [6] Nasution, N. S. Hubungan Kekuatan Otot Lengan Dan Percaya Diri Dengan Keterampilan Open Spike Pada Pembelajaran Permainan Bola Voli Atlet Pelatkab Bola Voli Putri Kabupaten Karawang. *JUDIKA.* 2015;3(2).
- [7] Garganta, J. Trends of tactical performance analysis in team sports: bridging the gap between research, training and competition. *RPCD.* 2009; 9(1):81-89.

- [8] Santoso, D. A. S., & Irwanto, E. Studi Analisis Biomechanics Langkah Awalan (Footwork Step) Open Spike Dalam Bola Voli Terhadap Power Otot Tungkai. *JORPRES*. 2018; 14(1):81-89.
- [9] Andibowo, T. Pengaruh Latihan Standing Servis dan Jumping Servis Terhadap Kemampuan Servis Atas Bola Voli. *JIP*. 2018;4(2).
- [10] Muklis. Survey Smash Dalam Kejuaraan Bola Voli Forsa Cup Putri Tahun 2014 / 2015 Di Desa Doko Kecamatan Ngasem Kabupaten Kediri. Kediri: Universitas Nusantara PGRI Kediri; 2014.
- [11] Palao, J., & Ahrabi-Fard, I. Side-out success in relation to setter's position on court in women's college volleyball. *Int. J. App. Sports Sci*. 2011; 23(1): 155-167.
- [12] Supriyadi, S., & Sunijantoro, A. G. Pengembangan Pola Latihan Penyerangan dalam Permainan Bola Voli Menggunakan Media Audio Visual pada Tim Bola Voli Putri UKM UABV Universitas Negeri Malang. *JSS*. 2018; 6(1).
- [13] Pranopik, M. R. Pengembangan Variasi Latihan Smash Bola Voli. *JPSI*. 2017; 1(1).
- [14] Ilham Surya Fallo, H. Upaya Meningkatkan Keterampilan Smash Permainan Bola Voli Melalui Pembelajaran Gaya Komando. *JPO*. 2016; 5(1):10-19.
- [15] Zuhermandi, Z., Sahputra, R., & Wakidi, W. Penerapan Media Bola Gantung Untuk Meningkatkan Aktivitas Smash Dalam Permainan Bola Voli Pada Siswakesel XB SMA Negeri 1 Nanga Pinoh. *JPKR*. 2015; 2(1):18-29.
- [16] Ahmadi, N. Panduan Olahraga Bola Voli. Surakarta: Era Pustaka Utama; 2007.
- [17] Kartikaningtyas, E. Pengaruh Metode Latihan Quick Smash Dengan Awalan Dan Tanpa Awalan Terhadap Hasil Quick Smash Dalam Permainan Bolavoli Pada Atlet Putra Klub PORVIT Kabupaten Kudus Tahun 2010. Semarang: Universitas Negeri Semarang; 2011.
- [18] Silva, M., Lacerda, D., & João, P. V. Match analysis of discrimination skills according to the setter defence zone position in high level volleyball. *Int. J. Perf. Anal. Spor*. 2014; 14(2):463-472.

Harvard Step Test and Cooper 12 Minute Test on Improvement of Fitness Index (VO2 Max) in Basket Athletes in Pekalongan City

Andung Maheswara Rakasiwi¹, Eko Budi Prasetyo², Irine Dwitasari Wulandari³
{maheswaraandung@gmail.com¹, hasan143173@gmail.com², irenealmerna@gmail.com³}

Pekalongan University, Pekalongan, Indonesia^{1,2,3}

Abstract. Fitness index is to know the ability of VO2 max which includes cardiovascular and cardiorespiratory fitness. In the Pekalongan city basketball athlete, the problem with athletes is the athlete's fitness condition, high level of activity or training activities. The purpose of doing a fitness index is to find out the effectiveness of providing a Harvard step test and 12-minute cooper test on basketball athlete fitness index to prevent collapsing of athletes while exercising. Pre and post-test group design method of the fitness ability of the athlete's index with the Harvard step test and cooper test methods. Research Results using measurements that have been made obtained results on the measurement of fitness index using harvard step test and cooper test of significant value. With better or increased endurance will reduce the risk of collapse in athletes caused by the inability to accept the portion of the exercise or compete.

Keywords: Harvard Step Test, 12 Minute Cooper Test, Fitness Index

1 Introduction

Sport has become a necessity of life for humans, exercise, especially health sports will be able to maintain and improve the degree of human life. Humans without sports activities will experience a decrease the physical condition so they are susceptible to various diseases. Sports activities from time to time always experience development because it is very needed for human life. Achievement sports are sports that in practice require intensive and leveled training because there is a target for achievement. Sports achievements are strongly influenced by the elements of tactics, techniques and the quality of physical conditions, so their development always involves research from experts. Every sports athlete needs good physical condition. Endurance athletes must also be good so that they are able to accept every training load given to achieve maximum performance. Endurance is the ability of the body's organs to work within a certain period. Endurance in sports is the ability of athletes to fight fatigue during activities or work. The cardiovascular system, breathing and circulatory system af-

affected and affects the quality of endurance systems. The factors that influence endurance are the maximum ability to meet oxygen consumption, which is characterized by $VO_2\text{max}$. $VO_2\text{max}$ is the maximum volume of O_2 that is processed by the human body during intensive activities. This $O_2\text{max}$ volume is a level of the body's ability, athletes who have high $VO_2\text{max}$ have good endurance and fitness [1].

Body fitness in an athlete is a major aspect that must be considered by an athlete, this fitness can be seen from the physical, psychological and functional athlete. When viewed the fitness component can consist of 2 aspects namely physical fitness and physical skills. Physical fitness includes cardiovascular endurance, muscle strength, muscle endurance, flexibility and body composition. While skills include speed, explosive power, balance, agility and coordination. Athletes need overall health conditions be able to give their full competitiveness. Imbalance in the body will certainly affect the performance of athletes when participating in competitions, one of which is the index fitness component.

The given exercise will respond to the increase in metabolism in the body as a result of increased activity carried out. A good response to the provision of proper training will be very beneficial for an athlete to be able to maintain stamina and avoid the risk of sports injuries. Cardiovascular response when doing exercise is influenced by the work of the heart which is increasing, this is marked by an increase in heart rate. Cardio respiration response will also increase according to the activities carried out, this is marked by an increase in pulse rate and the amount of breathing done [2].

Endurance of the body's organs in sports is the ability of athletes to fight fatigue during activities or work, endurance training is affected cardiovascular system, breathing and circulatory system. Therefore, the factors that influence endurance are the maximum ability to meet oxygen consumption, which is characterized by $VO_2\text{max}$. $VO_2\text{max}$ is the maximum volume of O_2 that is processed by the human body during intensive activities. This $O_2\text{max}$ volume is a level of the body's ability expressed in liters per minute or milliliters / minutes / kg body weight. Athletes who have high $VO_2\text{max}$ have good endurance and fitness [4].

For an athlete, fitness will be very much needed as an effort to achieve achievement targets, therefore providing proper training on the endurance of cardiorespiration, cardiovascular and flexibility of muscles as one of the main movers of the body. The training environment or competition will have different metabolic effects on the body. The training ground environment in the highlands or the cold environment or the training environment in the lowlands hot environment gives different effects on the body's metabolism. The body needs to adjust to the exercise activities carried out on the differences between the two environments. An athlete doing a competition in a hot environment will certainly accelerate metabolism in the body, spending more sweat and accompanied by a large amount of energy used so that the physical condition of an athlete will get tired more easily. If an athlete fights with a cold air environment will also have different effects on the body's metabolism. The heating is done and the process of burning the body's metabolism will be slow, energy will not quickly escape from the body [5].

Muscle, heart, cardiovascular or cardiorespiratory endurance is needed for athletes so that when athletes do exercises or compete in hot or cold environments it will make it easier for the body to adapt. So it will not reduce the risk of injury when competing or training. Seeing this, it is very necessary to measure the cardiovascular work

ability of an athlete. If the athlete has good quality cardiovascular endurance, then the risk of physical fatigue and heart collapse when the athlete does the exercise or compete will decrease. Measurement and improvement of cardiovascular endurance in accordance with the type of exercise practiced by an athlete. Therefore, researchers are interested to know the benefits of the Harvard step test and Cooper test for increasing endurance athletes in terms of the fitness index. This research will provide information for an athlete, agency manager, athlete trainer to be able to pay attention to athletes in terms of cardiovascular endurance and endurance to the activities of an athlete. Muscle, cardiovascular or cardiorespiratory endurance is needed for athletes so that when athletes do exercises or compete in hot or cold environments it will make it easier for the body to adapt. So it will not reduce the risk of injury when competing or training.

The cardiovascular system is a blood circulation organ consisting of the heart, blood components and blood vessels that function to deliver and supply oxygen and nutrients throughout the body's tissues that are needed in the body's metabolic processes. The cardiovascular system requires many varied mechanisms so that the regulatory function can respond to bodily activities, one of which is to increase blood supply activity so that tissue activity can be fulfilled. In severe circumstances, the blood flow is more directed at vital organs such as the heart and brain which function to maintain and maintain the circulatory system itself. Physical exercise is an activity a person does to improve or maintain physical fitness. Physical exercise is generally grouped into several categories, depending on the effect it has on the human body. Exercise results in physiological changes in almost all body systems, especially in the muscular and cardiovascular systems. The effect of exercise on the body is everything that happens in exercise. However, if the exercise load is too light, the effects of the exercise after recovery will be less than expected. If the training load is too heavy then the condition will return to normal. When an athlete does aerobic exercise, the heart and respiratory muscles become stronger. Also, blood pressure decreases athlete, and the number of blood cells increases. The body becomes more efficient and, as a result, exercises that were previously very heavy to become easier and add less weight to the body. Exercise becomes easier, so their ability to improve is reduced by overall fitness athletes [6].

Aerobic changes that occur in the aerobic system after exercise, namely increasing the content of myoglobin, the content of myoglobin in skeletal muscle has been shown to substantially increase the quality of training. Myoglobin is an oxygen-binding pigment that is similar to hemoglobin. In this case, it acts as a store for oxygen. However, this is considered a small function in contributing to the improvement of the aerobic system. Its main function is in helping the delivery (diffusion) of oxygen from the cell membrane to the mitochondria where it is consumed. Increased carbohydrate oxidation (glycogen). Training increases the capacity of skeletal muscle produce aerobic energy is increased. Evidence for this change is an increase in maximal aerobic power (VO₂ max) [7].

Blood and heart circulatory system, the main changes that result from clear training at rest are changes in heart size, decreased heart rate, increased stroke volume, increased blood volume and hemoglobin and changes in skeletal muscle. Changes during maximum training are common knowledge that physical training greatly increases maximum work capacity. Some of the physiological changes needed to bring

these improvements are an increase in maximal aerobic power, Increased cardiac output, Increased stroke volume, No change or slight decrease in heart rate, Increased lactic acid production, No changes in muscle blood flow.

Respiratory changes, ventilation is not a factor that can affect VO₂ max, the increase in maximal ventilation must be considered when increasing VO₂ max. The increase was caused by an increase in both tidal volume and respiratory rate. Training causes an increase in ventilation efficiency. Higher ventilation efficiency means that the amount of air ventilation at the same level of oxygen consumption is lower than in trained people. Because oxygen demand increases, it will also cause increased ventilation or air requirements in the lungs as a process of adaptation to greater oxygen demand. Some examples of activities or long activities such as running a marathon. oxygen to the respiratory muscles will be smaller than the need for oxygen in the skeletal muscles. Pulmonary volume can be measured in resting conditions (with the exception of tidal volume). Most of these changes can be attributed to the fact that training results can have a good effect on lung endurance. Athletes tend to have greater diffusion capacity at rest and during training than non-athletes. Diffusion of capacity per second is not directly affected by training. Greater lung volume in athletes will provide greater anatomy to form the alveolar and capillary capillaries.

2 Methods

This research is an experimental study with the research design used is quasi experiment design with pre and post-test group design. The population of this research is the basketball athletes KONI Pekalongan with research subjects as many as 30 people with the number of athletes aged 20 years 6 people, 21 years 12 people, 22 years 4 people, 23 years 2 people, 24 years 6 people. The early activity of this study was by asking permission to conduct research to the chairman of the KONI and the Chairperson of the Pekalongan Basketball Association as the person in charge as well as the field supervisor. Conducted socialization about the research to be carried out to KONI basketball players in Pekalongan City. Explain the purpose of the research and the procedures for conducting the research to be carried out by basketball coaches and athletes. The researcher sets the subject according to the inclusion and exclusion criteria set by the researcher. Sampling selecting athletes who represent the criteria, which have been determined by the inclusion criteria and the exclusions discussed in the eligibility criteria. Inclusion criteria included age, KONI Pekalongan athletes, willing to sample and sign informed consent, subjects with no history of physical abnormalities, subjects without cardiovascular or cardiovascular disease, patients with no structural abnormalities in posture, no other abnormalities were found. Exclusion criteria, namely subjects had posture abnormalities, subjects had a history of cardiovascular or cardiovascular disorders, a history of trauma to the vertebrae. The drop out criteria include subjects not being cooperative and not fulfilling the scheduled training program. Subjects during the study did not regularly follow the research procedures.

Data analysis includes several tests, namely the Fitness Index score comparison test between before and after training on the Harvard Step Test using a non-parametric comparison test, with the Wilcoxon match pair test. This test aims to de-

termine the Fitness Index score after the Harvard Step Test. The significance level used is $\alpha = 0.05$. Fitness Index score comparison test data between before and after training on the cooper test using the non parametric comparison test, with the Wilcoxon match pair test. This test aims to determine the Fitness index score after cooper test training. The significance level used is $\alpha = 0.05$. Fitness index score comparison test before training in the two groups using the parametric comparison test. This test aims to compare the average Fitness Index scores of the Harvard Step Test and Cooper Test groups. The significance level used is $\alpha = 0.05$.

3 Results and discussions

Subject characteristics include age, sex, description of the research subjects are presented in the following table.

Table 1. Characteristic of subject

	Frequency	Percent	Valid Percent	Cumulative Percent
Valid	20	6	20.0	20.0
	21	12	40.0	60.0
	22	4	13.3	73.3
	23	2	6.7	80.0
	24	6	20.0	100.0
Total	30	100.0	100.0	

From the table the number of subjects measured from male and female athletes in basketball is 30 athletes with several ages from the age of 20 to 6 people, 21 years 12 people, 22 years 4 people, 23 years 2 people and 24 years 6 people.

3.1 Pre test and post test harvard step test

On the results of the measurement to see differences in the results before the exercise and after the exercises are carried out can be said to have a significant difference if the p-value (p) obtained is smaller than 0.05 ($p < 0.05$). Based on the analysis, the t-count value of -6.552 with a probability value of $0.000 < 0.05$ shows that there is a significant result between pre-test and post-test in the Harvard Step Test. So it can be concluded that administering the Harvard Step Test can improve the basketball athlete fitness index.

3.2 Pre test and post test cooper test

On the results of the measurement to see differences in the results before the exercise and after the exercises are carried out can be said to have a significant difference if the p-value (p) obtained is smaller than 0.05 ($p < 0.05$). Based on Table pre and post test the value of t-count is -6.318 with a probability value of 0.000 p value < 0.05 , this shows that there are significant results between pre-test and post-test on the cooper test. So it can be concluded that administering the Cooper Test 12 minutes can improve the basketball athlete fitness index.

3.3 Effects of Harvard step test and cooper test on Fitness Indeks

The cardiovascular system performs work or activities to the maximum to pump blood and deliver oxygen to the muscles that contract, the release of adrenaline and lactic acid into the blood will increase heart rate. Sports activities will increase the work of several different components of the cardiovascular system. during the activity the skeletal muscle will increase cardiac output of the heart and blood flow from organs and inactive tissue will be redistributed to the active skeletal muscle. Skeletal muscle during exercise will increase cardiac output of the heart and blood flow from organs and inactive tissue will be redistributed to the active skeletal muscle. The body's response to physical stress carried out gives an increase in Heart Rate, Blood Pressure, Stroke volume, cardiac output, ventilation and VO₂ max. Heart rate is controlled by two nervous systems, namely parasympathetic and sympathetic. Parasympathetic nerves secrete ACh and decrease heart rate, whereas sympathetic nerves release norepinephrine and increase heart rate. At rest, sympathetic and parasympathetic nerve stimulation is in a balanced state. During exercise, parasympathetic stimulation decreases and sympathetic stimulation increases. Stroke volume (SV) is controlled by the final diastolic volume, average aortic blood pressure and the strength of ventricular contractions. The final diastolic volume = if the final diastolic volume increases, SV also increases. As the final diastolic volume increases, light stretching of the heart muscle fibers will increase the strength of the contractions. [1,8].

During sports activities blood flow also increases by decreasing the resistance of blood vessels to the systemic circulation of active skeletal muscle. Changes in oxygen delivery to the muscles during cardiac exercise increase with intensity until the maximum VO₂ is reached. During exercise, general vasodilation arises due to accumulation of vasodilatory metabolites. This results in decreased peripheral resistance, which in turn, strongly increases sympathetic activity through baroreceptor activation. Increased sympathetic activity causes vasoconstriction in the visceral organs, where vasodilation is predominantly in muscle blood vessels and coronary circulation due to local vasodilatory metabolites. Cutaneous blood vessels initially respond to sympathetic activity with vasoconstriction. As exercise progresses, reflex temperature is activated and causes cutaneous vasodilation to reduce heat production by muscle activity [4,9].

In this study the Harvard Step Test and Cooper Test methods provide cardiovascular adaptation responses due to structured and always increasing exercise, so that with increased training and activity will provide an increase in the fitness index of athletes. Many factors contribute to aerobic fitness, including the maximum capacity of the respiratory and cardiovascular system, a larger heart, red blood cells and more hemoglobin [10,11]. Genetic influence on muscle strength and muscle endurance is

generally associated with the composition of muscle fibers consisting of red and white fibers. Someone who has more is more appropriate to do activities that are aerobic, while those who have more white skeletal muscle fibers, are better able to do activities that are anaerobic. Age affects almost all components of fitness. Cardiovascular endurance shows a tendency to increase in childhood up to around twenty years and reach a maximum at the age of 20 to 30 years [12]. This endurance will decrease with age, with a decrease of 8-10% per decade for inactive individuals, whereas for active individuals the decline is 4-5% per decade [5,11]. Cardiovascular endurance at the age of children, between men and women is not much different, but after puberty there are differences. The average young woman has aerobic fitness between 15-25% smaller than young men and this depends on their level of activity. But in young women athletes who often practice only differ 10% below male athletes of the same age in terms of VO_{2max} . Women have 27% fat tissue from body composition more than men 15% of body composition [1]. Physical activity greatly affects all components of physical fitness, aerobic exercise that is done will increase cardiorespiration endurance can reduce body fat [12]. Increased blood pressure in less trained people than in untrained people, the effect of breathing exercises on the breasts including expanding the area occurs during growth, but not in adulthood. The number of breaths per minute is reduced, trained people breathe 6 to 8 times per minute, whereas in untrained people as much as 18 to 20 times per minute. Deeper breathing with diaphragms. In people who are not trained the diaphragm moves very little. In doing the same work, trained individuals breathe in smaller amounts of air, and take in more oxygen than untrained individuals.

4 Conclusions

Research conducted to determine the fitness results of the Pekalongan City Basketball Index with the Harvard Step Test and Cooper Test methods is one method that can be used to measure the fitness of an athlete. From the initial measurements before the two methods were given, the condition of the athletes was at a limit that still needed to be improved. This can be seen from the ability during training and the initial measurement results, after adding training activities using the Harvard Step Test and Cooper Test methods, it can be concluded that the training results show a significant increase in the physical abilities of the basketball athlete. The value obtained for each athlete increases, with these results expected to help a trainer to further improve training and for an athlete to be able to continue to improve endurance. With better or increased endurance will reduce the risk of collapse in athletes caused by the inability to accept the portion of the exercise or compete.

References

- [1] Bandyopadhyay A. Validity of Cooper's 12-minute run test for estimation of maximum oxygen uptake in male university students. *Biol. Sports.* 2105; 58(2): 59–63.
- [2] Cao ZB, Miyatake N, Aoyama T, Higuchi M, Tabata I. Prediction of Maximal Oxygen Uptake From a 3-Minute Walk Based on Gender, Age, and Body Composition. *J. Phys. Act. Health.* 2013; 10:280–7.
- [3] Sunil KR, Das, S.K. and Mahapatra, S. Determination of physical fitness index (PFI) with modified Harvard Step Test (HST) in young men and women. *Ind. J. Physiol and Allied Sci.* 1993; 47(2): 73-76.
- [4] Darmesh P. Study of Physical Fitness Index Using Modified Harvard Step Test in Relation with Gender in Physiotherapy Students. *IJSR.* 2015; 4(7):1215-1217.
- [5] Fletcher GF, Ades PA, Arena R, Balady GJ, Bittner VA. Exercise standards for testing and training: a scientific statement from the American Heart Association. *Circulation.* 2013; 128:873-934.
- [6] Myers J, Prakash M, Froelicher V Do D. Exercise capacity and mortality among men referred for exercise testing. *N Engl J Med.* 2002; 346:793-801.
- [7] The Impact of Physical Activity (Running) on Cardiovascular Outcomes, <https://www.acc.org/latest-in-cardiology/articles/2015/05/11/07/27/leisure-time-running-reduces-all-cause-and-cardiovascular-mortality-risk>, last accessed 25 June 2020.
- [8] Golbidi S, Laher I. Exercise and the Cardiovascular System. *Cardiol. Res. Pract.* 2012; 2012:1-15.
- [9] Suharjana. 2013. *Kebugaran Jasmani.* Yogyakarta: Jogja Global Media; 2013.
- [10] Exercise Physiology, <https://emedicine.medscape.com/article/88484-overview>, last accessed 25 June 2020.
- [11] Sharkey BJ. *Kebugaran & Kesehatan.* Jakarta: Raja Grafindo Persada; 2003.
- [12] Shashiala L, Geetanjali H., Banner R., Sanjeev K., Natraj SM. Efficiency of recovery pulse rate as an index of physical fitness. *JLS.* 2014. 4(2):216-219.

Mental Health Issues during COVID-19 Pandemic: Directions for Future Research

Anirotul Qoriah¹, Aftina Nurul Husna²
 {anirotulqoriah@mail.unnes.ac.id¹, anhusna@ummgl.ac.id²}

Universitas Negeri Semarang, Semarang Indonesia¹, Universitas Muhammadiyah Magelang,
 Magelang, Indonesia²

Abstract. Prolonged stress due to fear and uncertainty about Covid-19 pandemic situation might hamper people's ability to recover and live a new normal. However, public mental health during Covid-19 pandemic is relatively neglected topic in coronavirus-related study in Indonesia. Lacking of theoretical explanation regarding the nature of this issue, this article aims to explore conceptual progress documented in internationally published articles and to identify emerging topics on mental health issue and Covid-19 pandemic. We systematically reviewed 52 scientific articles consisting of original research, observation, literature review, letters to editor, and commentaries and concluded seven main themes: background and research methods, psychological responses, compromised quality of life, the vulnerable groups, well-being promotion efforts, potential of telemental health, and factors influencing well-being. Despite of limitations due to the method used, the findings may inform researchers and practitioners who concern in this issue to do similar investigation in Indonesia.

Keywords: mental health issues, Covid-19 pandemic, systematic literature review

1 Introduction

Covid-19 pandemic becomes a formidable non-natural disaster with seemingly no end in the near future. Covid-19 is an infectious disease caused by severe acute respiratory syndrome coronavirus 2 (SARS-CoV-2). It firstly emerged from Wuhan, China, in late December 2019 and now the outbreak has affected almost all countries around the world. World Health Organization (WHO) declared it a Global Public Health Emergency since January 30, and a Global Pandemic on March, 11. In only a half year, per June 2020, there are more than 450.000 fatalities with more than five millions confirmed cases from 216 countries [1].

In Indonesia, as Covid-19 begins to spread extensively in several provinces, on April 13 2020, Presidential Decree Number 12/ 2020 on Stipulation of Non-Natural Disasters of the Spread of COVID-19 as a National Disaster was signed by President

Joko Widodo [2]. To prevent Covid-19 patients overwhelming medical facilities, some local governments implement *Pembatasan Sosial Berskala Besar* (PSBB)/ Large Scale Social Restriction to limit people mobility and suppress virus transmission. People are told to stay at home and do self-quarantine after travel. Covid-19 prevention campaigns are so massive in media telling people to frequently wash hands, to use facial mask, to keep physical distance in public places, to avoid physical contact, and so on. School and workplace are closed for months; students and workers do their routines from home.

Impact of Covid-19 pandemic is devastating either for the infected people nor the uninfected by the disease. Medical personels, doctors and nurses, in the frontline of war against the virus are constantly under the risk. They must follow strict health protocols to avoid getting infected themselves, meanwhile personal protective equipment (PPE) is in shortage. Some must watch death of patients who cannot survive and see the grief of families left behind. Society in general is also greatly impacted especially by restrictive policy to contain the spread of the virus. Cities are under lockdown. Public places such as schools, markets, offices, and houses of worship, are closed. Study and work must be done online from home, creating imbalance in family life. People in isolation hardly meet and interact one each other and thus, lose social support. Economic activities are halted, leading to increasing number of unemployment and poverty.

Initially the spread of Covid-19 is health-related issue, but since it also causes social and economic disturbances, public mental health becomes a major concern by WHO [3]. People's well-being are at stake, not only on those who are previously healthy, but also those who already have existing mental health conditions. In some places, stigmatisation of people with Covid-19 as well as xenophobic attitude toward certain ethnic/ religious groups perceived as the source of the disease are alarming indications of social unrest. Worsening condition inevitably drives people to experience considerable degree of negative feelings such as loneliness, despair, fear, and worry. Drastic changes in daily life urge people to get ready and adapt to a new normal, to live together cautiously with the virus.

As scientists are still racing against the time to create vaccine and find drugs to cure Covid-19, mental health issue is considerably a less prioritized research focus. However, for long-term importance, anticipation of the impacts of prolonged stress experienced by medical personel and general public would be a necessity to help people becoming more resilient. In developing countries with weak society safety net and underdeveloped health systems, strenghten people from the inside would be a transformative effort. It brings opportunity for people to recover and live a new normal.

In Indonesia, research on mental health during Covid-19 pandemic is relatively low and not studied systematically. Topics of research are dominated by high concerns on bio-chemical, medical and epidemiological aspects of the disease [4–7], impact, policy and regulation regarding Covid-19 in health, education, and economic sectors [8–15], and factors contributing in Covid-19 occurence and recovery, such as weather [16] and sunlight exposure [17]. Therefore, this article tries to address the mental health issue during Covid-19 pandemic by conducting a systematic literature review. It aims to explore the progress of research and thoughts in this area and to map out emerging themes. Hopefully it will bring insights and more comprehensive

knowledge for future investigation which would be beneficial for the development of theories and practice in Covid-19 related problems.

2 Methods

2.1 Literatures Searching and Selecting Procedures

This qualitative study systematically reviews existing scientific on mental health issue during Covid-19 pandemic. A search was undertaken using search engine Google Scholar and keywords "mental health and Covid-19" and "Covid-19 in Indonesia". A total of 58 articles were retrieved which are all published in 2020 following the outbreak. The source of articles are ranging from journals in psychiatry, psychology, public health, medicine, clinical nursing, and forensic science. After thoroughly reviewing the contents, six articles were excluded because they are a brief case report in particular country. The rest 52 articles consist of original research, observational research, literature review, letters to editor, and editorials/ commentary related to mental health issues during Covid-19 pandemic.

2.2 Methodology of Literature Analysis

We conducted content analysis with procedures delineated as follow: 1) reading the articles carefully and taking some notes regarding important/ meaningful facts or ideas, 2) categorizing emerging themes and clustering them into fewer but broader main themes, 3) describing the main themes based on facts and ideas, and 4) summarizing the findings by presenting it using a table. Subsequently, we discuss the findings as conceptual framework for future research agenda.

3 Results and discussion

Table 1. Outline of Findings

No.	Main Themes	Sub Themes
1.	Background and research methods on Covid-19-related mental health issue	(1) Investigation of the nature of mental health problems as impacts of Covid-19 (2) Proposed methods to study mental health during Covid-19 pandemic (3) Research questions regarding mental health and Covid-19 pandemic
2.	Psychological responses to Covid-19	(1) Contextual factors behind psychosocial stress – Social restrictive policy (quarantine, social distancing, self-isolation) – Disruption in education, economic, and work life. (2) Kinds of psychosocial responses to Covid-19 – Emotional reactions – Unhealthy behavior – Non-compliance behavior
3.	Compromised quality of life as	(1) Dysfunction in social life (stigmatization, xenophobia, mass hysteria, & panic buying)

	side effect of Covid-19 measures	(2) Dysfunction in family life (domestic/ familial violence) (3) Decreased well-being on children and adolescent due to school closures
4.	The vulnerable groups	(1) Groups vulnerable to mental health problems during Covid-19 pandemic <ul style="list-style-type: none"> – People with direct/ indirect contact with the virus (patients and their relations) – People with physical & psychological existing condition (physical or mental illness) – Healthcare workers (doctors, nurses, & volunteers) – People exposed misinformation in media (2) Group vulnerable to risks from Covid-19 restrictive measures <ul style="list-style-type: none"> – Older and young people – Women – People of East Asian ethnicity – People with mental health problems, disability, or whose use substance or in recovery – People with reduced communication ability – Homeless people – People in institutions or criminal justice system – Workers with unsteady contract or on low income – Undocumented migrants
5.	Well-being promotion efforts	(1) Efforts in individual level (2) Efforts in group/ organizational level (3) Efforts in societal level
6.	Potential of telemental health	(1) Application of digital technology to deliver mental health services
7.	Factors influencing well-being during Covid-19 pandemic	(1) Experience of getting infected or under risk of getting infected (2) Government communication and public perception (3) Gender, relation with infected patient, history of medical problems, and occupation (4) Protective factors

3.1 Background and Research Methods on Covid-19-Related Mental Health Issues

Concerns about mental health issues during Covid-19 arise from observation of people behaviors as response to the disease as a threat. In early weeks of pandemic, media reported several phenomena, such as mass panic buying and increasing xenophobia (accusation and assault) toward Chinese-looking people in several countries. Public expressions characterized by anxiety and feeling unsafe are considered the early signs of mental health issue entailing Covid-19 outbreak. Negative societal behaviors are rooted in people's responses to fear and intolerance of uncertainty. Uncertainty alarms people to behave in extreme way in order to reduce feared uncontrollable situations. Also, when cause, progression, and outcome of the disease are not yet clear, misinformations are virally spread in social media and these lead people to posit close-minded attitude to deal with situation [18].

It takes some times for scientists starting to give more scrutiny on the nature of the problems as more incidents happened like suicide and self-harm [19,20] and fami-

ly violence [21,22]. Later survey research on population hardest hit by the outbreak at that time such as in China and Italy and on high risk groups such as healthcare workers, shows increasing cases of stress, anxiety, and depression [23,24]. Covid-19 precautionary measures such as self-isolation, quarantine, and social distancing/ restriction to general population cause environmental changes and subsequently, unintended psychological impacts [25,26]. The scale of the problem are so widespread and calling for action to set out long-term strategies.

Mental health research is very encouraged to support the mitigation effort. Various attempts are conducted to describe, understand and predict the progress of the issues, even though still in fragmented way by researcher around the world. First, by doing extensive literature review to find insights from previous mental health studies related to outbreaks in the past (e.g SARS, and MERS). Second, using survey (non-experimental quantitative study) to observe and monitor psychological needs and trend of mental health status of general population directly or indirectly affected by Covid-19. Surveys relied on self-report and may be conducted online utilizing surveillance application provided by government to be downloaded by citizens. Third, using qualitative approach to probe individuals' experience living under social restriction and having to cope with socioeconomic effects of the policies used to manage the pandemic. Qualitative research is also useful to understand causal mechanisms associated with poor mental health and identify sources of support available or protective factors [26]. Findings from multidisciplinary research would later be crucial information for intervention programs.

Several research questions are proposed by Holmes [26]: 1) What is the effect of Covid-19 on risk of anxiety, depression, and other outcomes, such as self-harm and suicide? 2) What is the optimal structure for a mentally healthy life during the outbreak and the period of social restriction? 3) What are the mental health consequences of the Covid-19 lockdown and social isolation for vulnerable groups, and how can these be mitigated under pandemic conditions? 4) What is the effect of repeated media consumption about Covid -19 in traditional and social media on mental health, and how can well-being be promoted? 5) What are the best methods for promoting well-being and adherence to behavioural advice about Covid-19 while enabling mental wellbeing and minimising distress?

3.2 Psychological Responses to Covid-19

Covid-19 pandemic affects individuals and overall society through several mechanisms: economy effects, social distancing and isolation, family relationship, health-related behaviors, disruption of social services, disrupted education and transportation, social disorder, and psychosocial effects [25,27]. Social restrictive policy (social distancing and isolation) drastically is altering what is familiar and complicating various aspects of daily life [25]. Social distancing may cause loss of income for many people in several ways. Some people may work at home, but some others lose their work completely. For those who work from home, school closures require them to provide childcare. This harshly affects family with low income and single parent. Low income increases psychosocial stress and those who are already poor will be worstly hit [27].

Social and economic changes due to public health emergency drive the psychosocial effects of Covid-19. These effects can range from emotional reactions (e.g. elevated stress, anxiety, and depression), unhealthy behaviors (e.g. substance use,

violence, and panicking) , and non-compliance to public health instructions (e.g. refuse to do self-isolation/ social restriction or to wear face mask) [28,29].

Even though Covid-19 mortality rate is lower than other respiratory diseases such as SARS and MERS, the fear of getting affected are prevalent in the mind of millions people around the globe. The fear does not solely originate from the life threatening disease. Multidimensional impacts of the disease, such as huge economic losses, the burden of quarantine and self-isolation, travel restriction, and strict monitoring and screening also play roles in shaping people's mind during pandemic. In addition, wide spread misinformation and misinfodemics in social media stir people to feel anxious [30]. Due to long-term destabilized mental health, increasing level of loneliness, depression, harmful alcohol and drug use, self-harm, suicidal behavior are expected to occur and anticipated [31]. Extreme fear and uncertainty, lower perceived health, negative societal behavior, health risk behavior, and mental disorder are other psychosocial effects of Covid-19 that should be examined attentively [31,32].

Psychological responses to the impacts of Covid-19 has a unique role in shaping attitude and behavior. People's psychological reactions toward Covid-19 pandemic play critical role in adherence to public health measures and ability to cope with the threat of infection. Inadaptive psychological reactions to pandemic may lead to maladaptive behaviors, emotional distress and defensive responses such as rejecting vaccination. Without proper psychological intervention in community, this would lead to increased risk of infection [33]. Among adaptive psychological reactions is functional fear of Covid-19 (fears about contracting the virus, feeling personally at risk of infection) which significantly predict risk-mitigating behaviors [34].

3.3 Compromised Quality of Life as Side Effect of Covid-19 Measures

Strict measures taken by authority to control pandemic might reduce the spread of Covid-19, but at the expense of people's quality of life. The Covid-19 pandemic is getting beyond a just medical phenomena; it disrupts normality and causes social dysfunction. It is indicated by the presence of stigma, xenophobia, mass hysteria, and panic behavior. In the early days of pandemic, people are reported panically buying medical and daily stuffs causing shortage of supplies in markets [30].

Problem related to family dysfunction arises in the form of increasing domestic/familial violence during quarantine period. This problem is paradoxical to government effort keeping society safe from Covid-19 outside but unintendedly confining children, women, and elderly in a dangerous situation with the abuser inside the house [22,35]. For people living with abusive relationships, staying at home is not safe at all and going outside provides relief and opportunity to look for help. Restrictive measure of pandemic indirectly causes unemployment, reduced income, limited resources, and limited social support. Those problems are likely combined in the household and subsequently become risk factors for family violence [21,22,36].

For children, decreased quality of life may link to the closures of school and campus. For children and adolescents with mental health needs like depression and autism, school closure means a lack of access to the resources they usually have through school such as peer-support group, psychological services, and school routines. For college and university students, sources of stress are related to dormitory evacuation and cancellation of anticipated important events such as final exam and

graduation ceremonies. After graduation, they are anxious about job market they are prepared for [37].

3.4 The Vulnerable Groups

The pandemic of Covid-19 affects everyone, but the impact on some groups or communities may be greater. Vulnerable groups are those who suffer direct impact of Covid-19 or indirectly affected by Covid-19 via responses to Covid-19 precautionary and mitigating measures. It is important to continue giving support to these groups who may experience mental health and psychosocial effects of Covid-19 pandemic: 1) those who have been directly/ indirectly in contact with the virus, 2) those who are already vulnerable to biological or psychosocial stressors, 3) health professional because of higher level of exposure, and 4) people who are following bad news in media [38].

In general population, there are 13 groups of people at particular risk from responses to Covid-19: 1) older people (at highest risk of severe Covid-19, especially those who live alone and not adept to use online communication), 2) young people (affected by societal disruptions in education or work sectors, most at risk of poor employment in longer term), 3) women (especially those who play role in childcare during school closure and potential to be victims of family violence), 4) people of East Asian ethnicity (due to xenophobia and social stigma as the pandemic is associated with China), 5) people with mental health problems (at risk of social isolation), 6) people who use substance or in recovery (at risk of relapse or withdrawal), 7) people with disability (affected by disrupted social services), 8) people with reduced communication ability (including those who have learning disability and limited literacy hampering ability to receive information and messages in media), 9) homeless people (may be unable to self-isolate and affected by disrupted social services), 10) people in criminal justice system (may be unable to self-isolate in prison setting or contact family), 11) undocumented migrants (may have no access or be reluctant to get to health services), 12) workers with unsteady contract or self-employment (at highest risk of losing work and have no income), 13) people on low income (already have poor health and insecure work), and 14) people in institutions (who live together in care homes or special need facilities) [27].

Unquestionably, health-care workers in hospitals or clinics, volunteers, and social service personnel are vulnerable to experience psychological break down while fulfilling their duties. Healthcare workers especially are reported experiencing insomnia, burnout, depressive symptoms, and post-traumatic stress disorder [30,39–42]. Compared to non-clinical staff in hospital, front line medical staff with close contact with infected patients were 1.4 times more likely to feel fear, twice more likely to suffer anxiety and depression [43]. Working under extreme pressures and shortage of personal protective equipment/ PPE, doctors may be unable to balance their own physical and mental health care and with those of patients due to duty [24,44]. Doctors are likely to experience moral injury, a psychological distress that results from actions which violate moral or ethical code. Unattended moral injury may lead to PTSD or depression, while providing support before, during, and after the incident may help them to gain psychological growth [44].

Eight sources of anxiety on healthcare professionals are identified as follow: 1) access to appropriate personal protective equipment/ PPE, 2) being exposed to Covid-19 at work and bringing the infection home, 3) not having rapid access to testing if they develop Covid-19 symptoms and concomitant fear of propagating infection at work, 4) uncertainty that their organization will support/take care of their personal and family needs if they develop infection, 5) access to childcare during increased work hours and school closures, 6) support for other personal and family needs as work hours and demands increase (food, hydration, lodging, transportation), 7) being able to provide competent medical care if deployed to a new area (eg, non-ICU nurses having to function as ICU nurses), and 8) lack of access to up-to-date information and communication [45].

The vulnerable groups are including those who endure quarantine for prolonged duration and with mental illness too [30,46,47]. Covid-19 pandemic measures such as area lockdown and personal hygiene instructions are likely to increase new onset Illness Anxiety Disorder in general population. On Obsessive Compulsive Disorder patients, especially those who have washing compulsion, their existing condition are likely getting worse. Disrupted daily routine and social rhythm increase stress level and may exacerbate people with depressive symptoms and chronic insomnia. [46]. Other vulnerable group are people with certain physical conditions such as Parkinson's Disease [48] and pregnancy [49]. Women in second and third trimester of pregnancy who have no worry about their health before pandemic are reported experiencing heightened health anxiety regarding their older relatives, their other children, their unborn baby, and their own health [49].

Lastly, patients and family members of infected patients are vulnerable too. Their experience are lacking exploration in previous literatures and their stories are less exposed in media too due to tendency to view mourning as a privat matter. Grief is a normal mourning that occur when death is expected. Grief is the most prevalent emotional response experienced by families left behind as common reactions after a loss. Grief is often accompanied with anxiety and depression or guilt and self-blame, and these contribute negatively to the quality of dying experience. Dynamic of grief on family members is related to social distancing/ isolation and inability to give proper funeral and burial for deceased patients [50].

3.5 Well-Being Promotion Efforts

Human-being has capacity to resilience so that most of affected people do not succumb to psychopathology during Covid-19 pandemic. People may find new strenght and experience personal growth as a result of adversity [29]. Normalization can be promoted through several ways: First, in individual level by 1) educating public about common stress responses like insomnia, panic attacks, health-related anxiety, fear of illness, increasing use of substance, irritability, isolation, and aggresion and 2) encouraging health-promoting behaviors and stress coping/ self-care methods such as sleep hygiene, activity scheduling, exercising, social connections, avoiding social media, and relaxation techniques [30].

Second, in group/ organizational level by 1) empowering family with knowledge about how to support and take care of its members, to facilitate social connection with significant others in isolation and loneliness [30], 2) integrating psychological intervention into health-care systems and community, and 3) providing psychological

guidance in work place especially hospital to attend emotional well-being of healthcare workers [40,51] as well as daily basic needs such as food, drink, rest facilities, and adequate PPE [42].

Third, in societal level by putting focus on people's mental health by infusing optimism and hope in mass communication practice [30,33,39]. Public health messages are suggested to focus on duties and responsibilities toward family, friends and fellow citizens with concern to the greater good [47].

3.6 Potential of Telemental Health

Digital technology begin to be applied in the effort of mitigating mental health issues during Covid-19 pandemic. Telemental health is the use of information and communication technology to provide mental health care remotely through for example video conferencing. Telemental health, tele-psychology, tele-psychiatry, or e-health are new field of collaborative research between psychologists/ psychiatrists, digital technology experts, and computer scientists [32,52].

Telemental health technology can bridge the gap in practices of psychology and psychiatry which now are discouraged to be carried out face-to-face [32]. When people have to minimize unurgent trip to hospital, the use of technology for communication is increasing. Psychological service goes online is becoming alternative trend, for example in a successful case of treating children and adolescents with eating disorders during Covid-19 pandemic in Singapore [53]. To ensure continuity of mental health service and care, video conferencing psychotherapy and internet interventions are among alternative solutions, despite of their weaknesses due to the nature of computer-mediated communication. Previously, online therapy is doubted and never fully integrated into normal part of routine care practice. Covid-19 pandemic thus becomes catalyst for wider acceptance and adoption of online approach by mental health professionals [54].

3.7 Factors Influencing Well-Being during Covid-19 Pandemic

Well-being during Covid-19 pandemic is measured through whether mental health problems such as stress, anxiety, and depression are present on individuals, and how it affects their functioning in daily life/ quality of life. Poor well-being is indicated by the increase of mental/ psychological distress. We found several factors affecting people's of well-being:

- a *Experience of getting infected or under risk of getting infected.* A study in China found that prevalence of depression is increasing in patients of Covid-19. However, both patients suffering Covid-19 and public in general together showing higher prevalence of depression comorbid with anxiety than individuals under quarantine. Depressed mood, somatic symptom, and anxious behavior indicated by becoming easily annoyed are reported in both groups too [55]. People under quarantine seemingly feel saver. Other than depression and anxiety, some people are reported to feel helpless, horrified, and apprehensive as well as increased stress from work [56].
- b *Government communication and public perception.* Public perception of an insufficient government response in handling the pandemic is associated with lower mental well-being. People who perceive their government are in control as showed in capability to put strong actions (for example, announcing a

nationwide lockdown) are more satisfied and thus have better mental well-being [57]. In other research in China, there is no immediate negative psychological effect of quarantine or no quarantine. Negative psychological consequences tend to raise from dissatisfaction with control measures implemented by the government. Poor communication causes failure ensuring the public that the quarantine or social restriction is acceptable and tolerable experience [58].

- c *Gender, relation with the infected patient, history of medical problems, and occupation.* From a study conducted in Italy, being female was associated with higher levels of depression, anxiety, and stress. Having acquaintances infected was associated with increased levels of both depression and stress. History of stressful situations and medical problems was associated with higher levels of depression and anxiety. Having a family member infected and young person who had to work outside their domicile were associated with higher levels of anxiety and stress. [59].
- d *Protective factors.* During Covid-19 pandemic, uncertainty and unpredictability in situation cause negative psychological impacts. However, some protective factors are found playing big role in moderating its severity and alleviating negativity: High confidence in medical personnel, perceived survivability, perceived low risk of infection, satisfaction with health information, and capability to implement personal precautionary measures [23].

3.8 Discussion

This literature study tries to fill the theoretical gap regarding Covid-19-related mental health issue. Through rigorous reading on international scientific literature, the thematic findings may inform researchers and mental health practitioners who concern with the issue specifically in Indonesia about how far the scientific endeavor has been going. We found seven main themes in literatures: background and research methods, psychological responses, compromised quality of life, the vulnerable groups, well-being promotion efforts, potential of telemental health, and factors influencing well-being. One of the themes, psychological responses to Covid-19, is expected and might seem familiar to those dwelling with mental health issue during a period of disaster in general. However, many emerging themes are novel to the recent Covid-19 outbreak.

Experiencing emotional distress such as fear, anxiety, and depression is a normal response people might show during disaster period and as the time goes, they would bounce back, adapt themselves, and continue living. It is mentioned that most people will not succumb into psychopathology after disaster [29]. However, in the context of Covid-19 pandemic, some factors should be taken into consideration because it is not like any other disaster in scale, duration, and severity in society. Natural and man-made disasters in general usually happen in only certain locality and with clear time of ending. Higher level of severity are experienced mostly by people directly impacted by the disaster. It gives chance for other unaffected community to give supports for the affected, so that general society may recover and turn to normal again. In comparison, Covid-19 pandemic is so widespread and left only few countries unaffected. The end of the pandemic is uncertain due to the absence of vaccine and countries are still struggling to contain its spread. In term of severity, millions people are directly affected as positive patients, while millions other are affected by its socially restrictive

mitigation measures. Covid-19 pandemic thus is no longer health phenomena since it causes huge social and economic disturbances.

This nature of Covid-19 pandemic explains why there are many vulnerable groups whose well-being must be supported by mental health system. Those groups are classified into two main groups: group of people who experience psychosocial effect of Covid-19 pandemic and those who are at high risk from precautionary measures to Covid-19. The second group experiences compromised well-being both in societal and familial level. It would be necessary to conduct follow up studies to explore and identify psychological needs of each groups and to give psychological interventions as support for their recovery. This applied approach is still lacking original research. Several articles discussed well-being promotional efforts as commentary and suggestion for stakeholders. As Covid-19 pandemic happened in digital era, there is a growing interest to develop telemental health or the use of digital information and communication technology to deliver mental healthcare services such as psychotherapy and counselling. This alternative is promising as Covid-19 pandemic becomes the unexpected catalisator. Development of telemental health would be the next research interest in mental health science.

Reflecting on this progress, many studies can be done in Indonesia. In comparison to the other worst hit countries by coronavirus such as China, Iran, India, Italy, or United States of America, Indonesia has unique cultural situation in the region of South East Asia. Like other countries, Indonesia also experiences economic downturn due to the pandemic. However, its society presumably shows more resilience and embraces the new normal quite easily. From observation of Indonesian social life, people are rushed to come back to their previous routine after Large Scale Social Restriction is relaxed in some locals with exception in only few sectors such as education. Hypothesized, religious beliefs may play big role in shaping Indonesians' mind so that they cannot be fearful or depressed any longer. Religious beliefs eases their emotional distress even though from scientific standpoint, it is discouraged because it may reduces alertness.

This literature study gives many insight for directions of future research especially in Indonesia. Using literature study, researcher may be able to find temporary answer based on available evidence before focusing it to a research question [60]. However, the results are challenged by several limitation especially in recent literature study. First, this study might not cover all available sources because researchers do not have access to any research database. The articles are searched using general search engine Google Scholar. Some articles were declined due to purchasing requirement. Second, the quality of findings is limited due to the quality of the sources which are dominated by commentary and observation articles. Despite of valuable informations found, they are lacking empirical evidence. Third, the findings are not free of subjectivity in the content screening process. The articles were retrieved from a vast array of scientific journal, from medicine to forensic science which are beyond both researchers' field of study (respectively, management and psychology). It is highly probable that some important facts are missed out.

4 Conclusion

Covid-19 pandemic has attracted attention of many health professionals, psychologists, and psychiatrists who concern with the mental status of effected populations around the world. Mental health issues are stem from inadapive psychosocial response, especially those are are classified into vulnerable groups, ranging from emotional reactions, unhealthy behaviors, and non-compliance to public health instructions. Efforts to promote well-being are suggested to be implemented in individual, group/ organizational, and societal level, which some begin to utilize digital technology. There is a need for more investigation in Indonesian context, either in form of preliminary or follow-up study about: the effect of Covid-19 on heightened risk of psychological problems, the consequences of restrictive measures for vulnerable groups, the effect of media exposure, the structure and dynamic of mentally healthy individuals, the intervention to promote well-being, or the role of culture and religion in the response of Covid-19. The findings would be beneficial to help mitigating the consequence of pandemic and to support Indonesia society to enter the new normal in adaptive way.

References

- [1] Novel coronavirus (COVID-19), https://www.who.int/bulletin/online_first/COVID-19/en/, last accessed 21 June 2020.
- [2] Gov't Declares COVID-19 Pandemic as National Disaster. <https://setkab.go.id/en/govt-declares-covid-19-pandemic-as-national-disaster/>, last accessed 21 June 2020.
- [3] Mental health and psychological resilience during the COVID-19 pandemic, <https://www.euro.who.int/en/health-topics/health-emergencies/coronavirus-covid-19/news/news/2020/3/mental-health-and-psychological-resilience-during-the-covid-19-pandemic>, last accessed 22 June 2020.
- [4] Harapan H, Itoh N, Yufika A, Winardi W, Keam S, Te H. Coronavirus disease 2019 (COVID-19): A literature review. *J Infect Public Health.*2020;13:667–73.
- [5] Khaerunnisa S, Kurniawan H, Awaluddin R, Suhartati S. Potential Inhibitor of COVID-19 Main Protease (M pro) from Several Medicinal Plant Compounds by Molecular Docking Study. Preprints. 2020;1–14.
- [6] Setiati S, Azwar MK. COVID-19 and Indonesia. *Acta Med Indones.* 2020;52:84–9.
- [7] Nuraini N, Khairudin K, Apri M. Modeling Simulation of COVID-19 in Indonesia based on Early Endemic Data. *Commun Biomath Sci.* 2020;3:1–8.
- [8] Yunus NR, Rezki A. Kebijakan Pemberlakuan Lock Down Sebagai Antisipasi Penyebaran Corona Virus Covid-19. *SALAM J Sos dan Budaya Syar-i.* 2020;7:227–37.
- [9] Telaumbanua D. Urgensi Pembentukan Aturan Terkait Pencegahan Covid-19 di Indonesia. *QALAMUNA J Pendidikan, Sos dan Agama.* 2020;12:59–70.
- [10] Abidah A, Hidayatullaah HN, Simamora RM, Fehabutar D, Mutakinati L. The Impact of Covid-19 to Indonesian Education and Its Relation to the Philosophy of “Merdeka Belajar.” *Stud Philos Sci Educ.* 2020;1:38–49.
- [11] Khasanah DRAU, Pramudibyanto H, Widuroyekti B. Pendidikan Dalam Masa Pandemi Covid-19. *J Sinestesia.* 2020;10:41–8.
- [12] Pujilestari Y. Dampak Positif Pembelajaran Online Dalam Sistem Pendidikan Indonesia Pasca Pandemi Covid-19. 'Adalah *Bul Huk Keadilan.* 2020;4:49–56.
- [13] Firman F, Rahayu S. Pembelajaran Online di Tengah Pandemi Covid-19. *Indones J Educ Sci.* 2020;2:81–9.

- [14] Muzakki F. The Global Political Economy Impact of Covid-19 and The Implication to Indonesia. *Joutnal Soc Polit Sci.* 2020;1:76–93.
- [15] Suryahadi A, Al Izzati R, Suryadarma D. The Impact of COVID-19 Outbreak on Poverty: An Estimation for Indonesia (Draft). SMERU Work. Pap. Jakarta; 2020.
- [16] Tosepu R, Gunawan J, Savitri D, Ode L, Imran A, Lestari H. Correlation between weather and Covid-19 pandemic in Jakarta, Indonesia. *Sci Total Environ.* 2020;725.
- [17] Asyary A, Veruswati M. Sunlight exposure increased Covid-19 recovery rates: A study in the central pandemic area of Indonesia. *Sci Total Environ.* 2020;729.
- [18] Usher K, Durkin J, Bhullar N. The COVID-19 pandemic and mental health impacts. *Int J Ment Health Nurs.* 2020;29:315–8.
- [19] Mamun MA, Griffiths MD. First COVID-19 suicide case in Bangladesh due to fear of COVID-19 and xenophobia: Possible suicide prevention strategies. *Asian J Psychiatr.* 2020;51:102073.
- [20] Sahoo S, Rani S, Parveen S, Singh AP, Mehra A, Chakrabarti S, et al. Self-harm and COVID-19 Pandemic: An emerging concern – A report of 2 cases from India. *Asian J Psychiatr.* 2020;51:102104.
- [21] Humphreys KL, Myint MT, Zeanah CH. Increased Risk for Family Violence During the COVID-19 Pandemic. *Pediatrics.* 2020;e20200982.
- [22] Campbell AM. An increasing risk of family violence during the Covid-19 pandemic: Strengthening community collaborations to save lives. *Forensic Sci Int Reports.* Elsevier B.V.; 2020;2:100089.
- [23] Wang C, Pan R, Wan X, Tan Y, Xu L, McIntyre RS, et al. A longitudinal study on the mental health of general population during the COVID-19 epidemic in China. *Brain, Behav Immun J.* 2020;87:40–8.
- [24] Wong AH, Pacella-LaBarbara ML, Ray JM, Ranney ML, Chang BP. Healing the Healer: Protecting Emergency Healthcare Workers' Mental Health During COVID-19. *Ann Emerg Med.* American College of Emergency Physicians; 2020;1–6.
- [25] Usher K, Bhullar N, Jackson D. Life in the pandemic: Social isolation and mental health. *J Clin Nurs.* 2020;1–2.
- [26] Holmes EA, O'Connor RC, Perry VH, Tracey I, Wessely S, Arseneault L, et al. Multidisciplinary research priorities for the COVID-19 pandemic: a call for action for mental health science. *The Lancet Psychiatry.* 2020;547–60.
- [27] Douglas M, Katikireddi SV, Taulbut M, McKee M, McCartney G. Mitigating the wider health effects of covid-19 pandemic response. *BMJ.* 2020;369:1–6.
- [28] Rajkumar RP. COVID-19 and mental health: A review of the existing literature. *Asian J Psychiatr.* 2020;52:102066.
- [29] Pfefferbaum B, North CS. Mental Health and the Covid-19 Pandemic. *N Engl J Med.* 2020;1–3.
- [30] Banerjee D. The COVID-19 outbreak: Crucial role the psychiatrists can play. *Asian J Psychiatr.* 2020;50.
- [31] Thakur V, Jain A. COVID 2019-suicides: A global psychological pandemic. *Brain Behav Immun.* 2020;
- [32] Čosić K, Popović S, Šarlija M, Kesedžić I. Impact of human disasters and Covid-19 pandemic on mental health: Potential of digital psychiatry. *Psychiatr Danub.* 2020;32:25–31.
- [33] Cullen W, Gulati G, Kelly BD. Mental health in the COVID-19 pandemic. *QJM An Int J Med.* 2020;1–2.
- [34] Harper CA, Satchell LP, Fido D, Litzman RD. Functional Fear Predicts Public Health Compliance in the COVID-19 Pandemic. *Int J Ment Health Addict.* 2020;
- [35] Bradbury-Jones C, Isham L. The pandemic paradox: The consequences of COVID-19 on domestic violence. *J Clin Nurs.* 2020;19:2047–9.

- [36] Usher K, Bhullar N, Durkin J, Gyamfi N, Jackson D. Family violence and COVID-19: Increased vulnerability and reduced options for support. *Int J Ment Health Nurs*. 2020;
- [37] Lee J. Mental health effects of school closures during COVID-19. *Lancet Child Adolesc Heal*. Elsevier Ltd; 2020;4:421.
- [38] Fiorillo A, Gorwood P. The consequences of the COVID-19 pandemic on mental health and implications for clinical practice. *Eur Psychiatry*. 2020;63:e32, 1–2.
- [39] Burdorf A, Porru F, Rugulies R. The COVID-19 (Coronavirus) pandemic: Consequences for occupational health. *Scand J Work Environ Heal*. 2020;46:229–30.
- [40] Galbraith N, Boyda D, McFeeters D, Hassan T. The mental health of doctors during the Covid-19 pandemic. *BJPsych Bull*. 2020;1–7.
- [41] Pappa S, Ntella V, Giannakas T, Giannakoulis VG, Papoutsis E, Katsaounou P. Prevalence of depression, anxiety, and insomnia among healthcare workers during the COVID-19 pandemic: A systematic review and meta-analysis. *Brain Behav Immun*.; 2020;1–7.
- [42] Walton M, Murray E, Christian MD. Mental health care for medical staff and affiliated healthcare workers during the COVID-19 pandemic. *Eur Hear J Acute Cardiovasc Care*. 2020;9:241–7.
- [43] Lu W, Wang H, Lin Y, Li L. Psychological status of medical workforce during the COVID-19 pandemic: A cross-sectional study. *Psychiatry Res*. 2020;288.
- [44] Greenberg N, Docherty M, Gnanapragasam S, Wessely S. Managing mental health challenges faced by healthcare workers during covid-19 pandemic. *BMJ*. 2020;368:10–2.
- [45] Shanafelt T, Ripp J, Trockel M. Understanding and Addressing Sources of Anxiety among Health Care Professionals during the COVID-19 Pandemic. *JAMA - J Am Med Assoc*. 2020;323:2133–4.
- [46] Chatterjee SS, Malathesh BC, Mukherjee A. Impact of COVID-19 pandemic on pre-existing mental health problems. *Asian J Psychiatr*. 2020;51.
- [47] Druss BG. Addressing the COVID-19 Pandemic in Populations With Serious Mental Illness. *JAMA - J Am Med Assoc*. 2020;E1–2.
- [48] Helmich RC, Bloem BR. The Impact of the COVID-19 Pandemic on Parkinson's Disease: Hidden Sorrows and Emerging Opportunities. *J Parkinsons Dis*. 2020;10:351–4.
- [49] Corbett GA, Milne SJ, Hehir MP, Lindow SW, O'connell MP. Health Anxiety and Behavioural Changes of Pregnant Women During the Covid-19 Pandemic. *Eur J Obstet Gynecol Reprod Biol*. 2020;249:96–7.
- [50] Wallace CL, Wladkowski SP, Gibson A, White P. Grief During the COVID-19 Pandemic: Considerations for Palliative Care Providers. *J Pain Symptom Manage*. Elsevier Inc; 2020;60:e70–6.
- [51] Ripp J, Peccoraro L, Charney D. Attending to the Emotional Well-Being of the Health Care Workforce in a New York City Health System During the COVID-19 Pandemic. *Acad Med*. 2020;1–4.
- [52] Whaibeh E, Mahmoud H, Naal H. Telemental Health in the Context of a Pandemic: the COVID-19 Experience. *Curr Treat Options Psychiatry*. Current Treatment Options in Psychiatry; 2020;
- [53] Davis C, Ng KC, Oh JY, Baeg A, Rajasegaran K, Chew CSE. Caring for Children and Adolescents With Eating Disorders in the Current Coronavirus 19 Pandemic: A Singapore Perspective. *J Adolesc Heal*. Elsevier Inc.; 2020;1–4.
- [54] Wind TR, Rijkeboer M, Andersson G, Riper H. The COVID-19 pandemic: The 'black swan' for mental health care and a turning point for e-health. *Internet Interv*. Elsevier; 2020;20:100317.
- [55] Zhang J, Lu H, Zeng H, Zhang S, Du Q, Jiang T, et al. The differential psychological distress of populations affected by the COVID-19 pandemic. *Brain, Behav Immun J*. 2020;87:49–50.

- [56] Zhang Y, Ma ZF. Impact of the COVID-19 pandemic on mental health and quality of life among local residents in Liaoning Province, China: A cross-sectional study. *Int J Environ Res Public Health*. 2020;17.
- [57] Fetzer T, Witte M, Hensel L, Jachimowicz JM, Haushofer J, Ivchenko A, et al. Perceptions of an Insufficient Government Response at the Onset of the COVID-19 Pandemic are Associated with Lower Mental Well-Being. *PsyArXiv*. 2020;
- [58] Zhu S, Wu Y, Zu C, Hong W, Yu Z, Chen Z, et al. The immediate mental health impacts of the COVID-19 pandemic among people with or without quarantine managements. *Brain Behav Immun*. 2020;87:56–8.
- [59] Mazza C, Ricci E, Biondi S, Colasanti M, Ferracuti S, Napoli C, et al. A nationwide survey of psychological distress among Italian people during the covid-19 pandemic: Immediate psychological responses and associated factors. *Int J Environ Res Public Health*. 2020;17:1–14.
- [60] Mallett R, Hagen-Zanker J, Slater R, Duvendack M. The benefits and challenges of using systematic reviews in international development research. *J Dev Eff*. 2012;4:445–55.

Giving Belly Breathing Technique and Positive Affirmation of Stress and Cortisol Hormone Levels in Third Trimester Pregnant Women

Annisa Septy Nurcahyani¹, Runjati², Sri Achadi Nugraheni³
 {annisaseptyn@gmail.com¹, runjati@yahoo.com², s.a.nugraheni.undip@gmail.com³}

Poltekkes Kemenkes Semarang, Semarang, Indonesia^{1,2,3}

Abstract. During pregnancy the mother has mood changing or increased anxiety which can make the mother stressed. Belly breathing techniques and positive affirmations can be an alternative for pregnant women to reduce stress levels. The design of this study was a quasi experiment with a non randomized pretest posttest with control group design. A total of 40 respondents domiciled around Public Health Center of Kalimanah, Padamara, and Purbalingga were divided into intervention and control groups. Stress level evaluated with DASS-42 and cortisol evaluated with serum blood (3 cc). The p-value (*wilcoxon*) before and after the treatment showed the treatment of belly breathing techniques and positive affirmation can affect stress and cortisol in the pregnant women significantly. Belly breathing techniques and positive affirmations can be suggested to be material in the class of pregnant women so the pregnant woman more calm, more comfortable, has a positive and confident during her pregnancy.

Keywords: belly breathing, positive affirmations, stress, cortisol

1 Introduction

During pregnancy, some pregnant women has psychological or mental changing [1]. Pregnancy woman has stress because of unbalance estrogen and progesterone hormones that can make uncomfot pregnancy such as mood swing, anxiety, fear and panic [2–4]. Stress is triggered by the mother's concern about her condition such as fear of miscarriage, fetal development is not appropriate, fear of labor, fear of not being able to normal delivery, too often hear negative experiences other people's and pain during deliver the baby [1,5].

Stress is a condition where the body's response is not specific to anything [6]. Stress affects a person's psychology, nervous system, endocrine and immune system [7]. Stress in pregnant women can affect the baby, depression during the puerperium and increase high blood pressure [8,9]. In the world, the incidence of high blood pressure during pregnancy is around 10% [10] whereas in Indonesia, high blood pressure

in pregnant women has 27.1% [11]. High blood pressure in pregnant women increases the risk of preeclampsia and eclampsia [12]. In addition, stress causes the mother to have insomnia.

Some factors can cause stress of pregnant women such as worries, have negative thoughts about themselves, worrying care for babies properly and having negative recordings because they often hear fear stories of labor [1,2]. Stress in pregnant woman will produce corticotropin in hypothalamus and stimulate the production of adrenocortisol and release cortisol [8,13]. Non-pharmacological therapies can help pregnant women reduce their stress levels include pregnancy exercise, prenatal yoga, listening Al-Qur'an murotal and SEFT (Spiritual Emotional Freedom Technique) [4]. However, there are other therapies such as relaxation of breath and positive affirmations can be alternative for pregnant women to reduce stress levels. According to Ilmiasih research, pregnant women will relax and comfortable, reduce anxiety when practice breathing relaxation and positive affirmations to themselves consistently. When relaxed, the body releases serotonin hormones and endorphins, so all nervous system balance [3].

2 Materials and methods

Research in this study use quasi experiment with a non-randomized pretest post-test with control group design. Subject was chosen based on the criteria of the researcher, sample was taken by non-randomized sampling method, purposive sampling technique and after the subject was selected, the researcher divided respondents into control and intervention group.

This research was conducted in Kalimanah, Padamara, Purbalingga Public Health Center working area. Respondents in this study were pregnant women 20 - 35 years old, 28-36 weeks gestational age. Measurement of stress levels using Depression Anxiety Stress Scale (DASS 42) questionnaire. DASS 42 consists of 42 question items covering three sub-variables physical, emotional and behavioral. Based on Cronbach's Alpha DASS 42 has a value of validity and reliability of 0.91. Stress categories in DASS 42 are divided into five categories: normal, mild, moderate, severe and very severe. Measurement of respondent's serum cortisol level was stored and analyzed in the laboratory of GAKI Faculty of Medicine, Diponegoro University, Semarang.

Researchers gave intervention belly breathing techniques and positive affirmations 4 times in 2 weeks with 20 minutes duration. Intervention group receive belly breathing techniques, positive affirmations and counseling, information education, while the control group only get counseling, information and education.

3 Results

3.1 Giving Belly Breathing Technique and Positive Affirmation of Stress in Pregnant Women

Based on results in this research pre-intervention average of stress level 16.70 and control group 15.85. Post intervention averaged 8.15 and control group 15.15. Stress levels in intervention and control groups decreased, p-value (wilcoxon) before and after treatment of belly breathing techniques and positive affirmations have <0.05 , it means there are significant differences before and after treatment of belly breathing techniques and positive affirmation.

Table 1. Giving Belly Breathing Technique and Positive Affirmation of Stress in Pregnant Women

Variabel	Group		<i>p value</i>	
	Intervention Mean±SD	Control Mean±SD		
Stress	Pre	16,70±2,6	15,85±1,1	0,82**
	Post	8,15±3,6	15,15±2,1	0,00**
<i>p-value</i>		0,00*	0,00*	
	Δ	8,55±3,2	0,70±2,0	0,00**

*Wilcoxon

**Mann Whitney

3.2 Giving Belly Breathing Technique and Positive Affirmation of Cortisol Hormone Levels in Pregnant Women

Based on result of cortisol hormone levels is 136.95 for pre intervention and 111.40 for post intervention, while control group pre-intervention was 111.15 and 104.50 for post intervention. The p value (wilcoxon) before and after treatment of belly breathing techniques and positive affirmations have a value <0.05 , it means concluded that there are significant differences before and after treatment of belly breathing techniques and positive affirmation of cortisol hormone.

Table 2. Giving Belly Breathing Technique and Positive Affirmation of Cortisol Hormone Levels in Pregnant Women

Variabel	Group		<i>p value</i>	
	Intervention Mean±SD	Control Mean±SD		
Cortisol	Pre	136,9±37,0	111,4±74,0	0,82**
	Post	111,1±27,1	104,5±66,0	0,00**
<i>p-value</i>		0,00*	0,00*	
	Δ	25,8±23,1	6,9±25,3	0,00**

*Wilcoxon

**Mann Whitney

4 Discussions

4.1 Giving Belly Breathing Technique and Positive Affirmation of Stress in Pregnant Women

Based on results in this study, belly breathing techniques and positive affirmations 4 times in 2 weeks with a duration of 20 minutes in pregnant women can affect stress levels of pregnant women. The p-value (wilcoxon) before and after treatment belly breathing techniques and positive affirmations have a value <0.05 , so it means concluded that there are significant differences before and after treatment of belly breathing techniques and positive affirmation of stress. Mann Whitney test results on the two groups in pre-test obtained 0.820 results which can be interpreted there is no difference between the two groups before treatment and the results of post-test results obtained 0,000 which means there is a difference between the two groups after treatment.

Pregnancy causes many physical and psychological changes; this is due to hormonal changes in pregnant women. Psychological changes such as worry by changes in body shape, worry that the fetus is born in abnormal condition, fear, anxiety and stress. Family support internally and externally can cause pregnant women to worry excessively, fear and stress, especially the third trimester because mother and family wait the baby [14].

Belly breathing teaches pregnant women to breathe deeply and exhale slowly [15]. Belly breathing takes maximum air and toxins from the lungs and helps oxygen to the lungs. When breathing deeply and regularly, breathing will slower so pulse and heart beat also decrease [16]. Belly breathing increase alveoli ventilation, reduce stress both physically and emotionally which can help reduce pain and anxiety [15]. Results of this study showed the group given belly breathing techniques decreased stress in the intervention group. This means that the breathing relaxation technique can maximize oxygen entering the lungs, make breathing slow and reduce stress in pregnant women. Stress in pregnant women caused by physical factors such as forced physical exercise, sound environmental conditions, air pollution, temperature, radiation, food consumed, additives and trauma [17]. Besides the source stress is also obtained from daily problems [18]. Same with Makwa and Hidayati's research that breathing relaxation helps reduce stress levels, makes the body more comfortable and reduces negative emotions [19].

Besides belly breathing techniques researchers also gave positive affirmations to pregnant women. According to Dr. Carmen Harra clinical psychological expert, positive affirmations can affect the universe, when word comes out in the form of sound, waves to the universe, penetrate the air and become real. When speaking "I am healthy" universe will give the ability to do that. Affirmations can affect the subconscious mind and give suggestions to yourself [14].

Researchers gave positive affirmations such as "My pregnancy is healthy", "Strong membranes", "Placenta healthy", "Smooth delivery", "When the contraction came, I always smile" with the aim of giving positive energy to pregnant women to reduce anxiety and stress. The results of this study mention the intervention group greater reduction than control group who have not positive affirmation treatment. Accordance of Indrayani and Sumarni's research, self-affirmation is effective to re-

duce level of anxiety that can cause stress in the mother, positive thoughts can expedite blood flow so that stress can be reduced [20].

4.2 Giving Belly Breathing Technique and Positive Affirmation of Cortisol Hormone Levels in Pregnant Women

Based on results of this study the p-value (wilcoxon) before and after the treatment of belly breathing techniques and positive affirmations <0.05 . Mann Whitney test results on the two groups in pre-test showed 0.010 results which can be interpreted that there are differences between the two groups before treatment and the results of the post-test results obtained 0.149 which means there is no difference between the two groups after treatment, so it can be concluded that there are differences significant between the two groups after being given an intervention.

Relaxation during pregnancy significantly reduce stress levels in pregnant women by blood pressure, pulse, decreased cortisol levels [21]. High cortisol hormone levels in the body can affect immune system, brain memory disorders, depression, osteoporosis, high blood pressure and insulin resistance [22]. Belly breathing technique is one of the relaxation techniques can be performed by pregnant women.

Belly breathing techniques and positive affirmations was given 4 times in 2 weeks with a duration of 20 minutes in pregnant women affect cortisol hormone levels in pregnant women. Results of Lestari's, Ahmad and Prasanto research doing deep breathing routinely can help lower blood pressure and helps reduce cortisol levels in the body [23]. Belly breathing can improve the parasympathetic system, provide a calming effect and stimulate the release of oxytocin and reducing cortisol [24].

The results showed that there were differences in cortisol hormone levels before being given an intervention and there was no difference after being given an intervention, there was a selective decrease but it was possible not because of the intervention given. Based on research Maulia and Ambarwati breath relaxation 3 times a day with a duration of 15 minutes can reduce blood sugar levels so that stress decreases and affects cortisol hormone levels [25]. In this study the breathing technique was only carried out for 10 minutes. Less intense duration may be one of the factors causing a significant decrease in cortisol.

Positive affirmations are affirmation to yourself to get rid of negative beliefs that exist in the subconscious mind [26]. Positive affirmations prepared for pregnant women to have physical and mental health which motivating, inspiring, providing support, changing perspectives, affecting the body, soul and mind to become daily behavior [27]. Andriyani research results, positive affirmations help reduce tension, sleep more soundly, stay relaxed, reduce feelings of worry about bad things so that the brain center of emotions (hypothalamus) control neuroendocrine, including cortisol [28]. Although the results of this study have not shown a significant decrease in cortisol hormone levels, other references continue positive emotional responses, a calmer self will make the hypothalamus decrease CRF secretion, a decrease in CRF stimulates a decrease in ACTH and has an effect on decreasing cortisol secretion [29].

Cortisol regulation can be improved when opioids, serotonin and GABA in amygdala be regulated by the activity limbic system that affected by positive affirmations, so pregnant woman feeling comfortable [14]. This is different with the results of this study where cortisol levels have not dropped significantly, this is possible

when giving positive affirmations that pregnant women are not focused and not affected limbic system in the amygdala (cortisol) [30].

5 Conclusion

Based on the results of this research belly breathing techniques and positive affirmations have effect on stress and cortisol hormone levels in pregnant women, it can be concluded that belly breathing techniques and positive affirmations 4 times in 2 weeks with a duration of 20 minutes effect on stress reduction and cortisol levels in pregnant women. Researchers combine other non-pharmacological interventions, increasing the duration of intervention to make it more effective in reducing stress and cortisol levels in pregnant women.

References

- [1] Aziz NA, Margaretha. Strategi Coping Terhadap Kecemasan Pada Ibu Hamil dengan Riwayat Keguguran di Kehamilan Sebelumnya. *J Ilm Psikol Terap.* 2017;05:200.
- [2] Kuswandi L. *Hypnobirthing: A Gentle Way to Give Birth.* Jakarta: Pustaka Bunda; 2013.
- [3] Ilmiasih R. Pengaruh Teknik Hypnobirthing Terhadap Tingkat Kecemasa Ibu Hamil Pada Masa Persiapan Menghadapi Persalinan. 2017;93–100.
- [4] Susilowati T, Pramana N, Muis SF. Non-Pharmacological Intervention on Anxiety Primigravida. *J Ilm Permas J STIKES Kendal.* 2019;9:181–6.
- [5] Larasati IP, Wibowo A. Pengaruh Keikutsertaan Senam Hamil Terhadap Kecemasan Primigravida Trimester Ketiga Dalam Menghadapi Persalinan. *J Biometrika dan Kependud.* 2012;1:26–32.
- [6] Fink G. *Stress : Concepts Definition , History.* Ref Modul Neurosci Biobehav Psychol. 2016;
- [7] Perciavalle V, Blandini M, Fecarotta P, Buscemi A, Di Corrado D, Bertolo L. The Role of Deep Breathing on Stress. *Neurol Sci.* 2017;38:451–8.
- [8] Chen PJ, Yang L, Chou CC, Li CC, Chang YC, Liaw JJ. Effects of Prenatal Yoga on Women’s Stress and Immune Function Across Pregnancy: A randomized Controlled Trial. *Complement Ther Med.* Elsevier Ltd; 2017;31:109–17.
- [9] Corbijn van Willenswaard K, Lynn F, McNeill J, McQueen K, Dennis CL, Lobel M. Music interventions to reduce stress and anxiety in pregnancy: A systematic review and meta-analysis. *BMC Psychiatry.* BMC Psychiatry; 2017;17:1–9.
- [10] Magee LA, Von Dadelszen P, Rey E, Ross S, Asztalos E, Murphy KE. Less-tight versus tight control of hypertension in pregnancy. *N Engl J Med.* 2015;372:407–17.
- [11] Lombo G, Wagey F, Mamengko L. Observations of Control System Design: Problems and Promise. *J Kedokt Klin.* 2017;1:9–15.
- [12] Kaimuddin L, Pangemanan D, Bidjuni H. Hubungan Usia Ibu Saat Hamil Dengan Kejadian Hipertensi Di RSUD GMIM Pancaran Kasih Manado. *J Keperawatan.* 2018;6:1–5.
- [13] Primawati AS, Widyawati MN, Admini A. Penurunan Tingkat Stres Ibu Hamil Dengan Terapi Musik Dan Aromatherapy Pada Kelas Ibu Hamil. *J Kebidanan.* 2018;8:37.
- [14] Cholifah N, Fahrinda R, Hartinah D. Pengaruh Pemberian Afiriasi Positif Terhadap Perubahan Psikologis Ibu Hamil dengan Pre Eklampsia di Klinik Kandungan RSUD RA Kartini Kabupaten Jepara Tahun 2017. *Indones J Perawat.* 2017;2:80–6.
- [15] Irawan FD, Sudiwati NLPE, Dewi N. Perbandingan Tekhnik Relaksasi Nafas Dalam dan Kompres Dingin Terhadap Penurunan Tingka Nyeri haid (Dismenore) Pada Mahasiswi di

- Asrama Sanggau dan Ikatan Keluarga Belu di Landungsari Kota Malang. *Nurs News (Meriden)*. 2016;1:358–68.
- [16] Yoga TTPG. *Modul Prenatal Gentle Yoga*. PT Kristala Permata Nusantara; 2018.
- [17] Rahmayani MP, Rohmatin E, Wulandara Q. Pengaruh Terapi Murotal Al-Qur'an Terhadap Tingkat Stres Pada Pasien Abortus di RSUD dr. Soekardjo Kota Tasikmalaya Tahun 2018. *J Bidan "Midwife Journal."* 2018;4:36–41.
- [18] Lumban Gaol NT. Teori Stres: Stimulus, Respons, dan Transaksional. *Bul Psikol.* 2016;24:1.
- [19] Makwa DJ, Hidayati E. Relaksasi Untuk Mengatasi Stres Sehari-hari Pada Lansia. *Pros Temilnas XI IPII*. 2019. p. 20–1.
- [20] Indrayani T, Sumarni W. Efektivitas Afiriasi Tenaga Kesehatan Pada Tingkat Kecemasan Ibu Bersalin Multipara Di RSUD Bula Kabupaten Seram Bagian Timur Tahun 2018/2019. *J Ilmu dan Budaya*. 2019;41:7489–94.
- [21] Septianingrum Y. Terhadap Penurunan Stres, Kecemasan. *J Ilm Kesehat*. 2015;8:206–12.
- [22] Shopia, Seotriyana N, Nuzulmi A. Efektivitas Pranayama Terhadap Penurunan Kecemasan Pada Ibu Hamil Trimester III. *Pertem Ilm Nas Penelit dan Pengabd Masy*. 2018;1:432–9.
- [23] Lestari ADP, Ahmad RA, Prasanto H. Efek Metode Deep Dan Affirmation Positif Pada Penurunan Tekanan Darah Pasien Hipertensi Di Kulon Progo. *J Community Med Publik Heal*. 2017;Vol. 33 No:1–6.
- [24] Salafas E, Anisa; R, Rusita; VI. Efektivitas Hypno-Eft dan Pernafasan Yoga dalam Memurunkan Kecemasan Ibu Hamil di BPM Ny. Sri Kustinah. 2016;7:84–94.
- [25] Rizki Maulia I. Terapi Relaksasi Teknik Nafas Dalam (Deep Breathing) Dalam Menurunkan Kadar Gula. *J Profesi Keperawatan*. 2017;4:59–67.
- [26] Yuwinten, Tajmiati A, Nurvita N. Pengaruh Komunikasi Afiriasi Terhadap Durasi Mual Muntah Ibu Hamil Trimster I Kecamatan Cibereum Kota Tasikmalaya Tahun 2018. *J Kesehat Bakti Tunas Husada J Ilmu Keperawatan*. 2018;18:237–48.
- [27] Syaras D, Yasir Y, Wirman W. Komunikasi Intrapersonal Pasien Hypnobirthing Di Rumah Sakit Bersalin Annisa Pekanbaru. *J Ris Komun*. 2019;2:13–20.
- [28] Andriyani A, Sulaeman JSJ, Marhaeni D. Kelas Hypnobirthing Sebagai Mind-Body and Interventions: Study Kualitatif Di Puskesmas Rawat Inap Kota Yogyakarta. *J Ilmu Kebidanan*. 2016;4:37–52.
- [29] Lisdiana. *Regulasi Kortisol Pada Kondisi Stres Dan Addiction*. Biosaintifika J Biol Educ. 2012;4.
- [30] Indonesia H. *Modul Panduan Pelatihan Basic Hypnosis dan Hypnobirthing*. Jakarta: PT Kristala Permata Nusantara; 2019.

The Relationship Between Physical Fitness, Discipline and Motivation of UNNES Security Performance

Aristiyanto¹
{aristiyanto01@gmail.com¹}

Universitas Ngudi Waluyo, Semarang, Indonesia¹

Abstract. This study aims to analyze and describe the relationship between the independent variables and the dependent variable. This type of research uses quantitative correlational. The number of samples used was 61 from a population of 109 members of UNNES security s. The instrument used was the kesamaptaan test and questionnaire sheets. Data analysis using correlation and regression, the results showed: (1) physical fitness made an effective contribution of 10,8%, (2) discipline made an effective contribution of 46,3%, (3) motivation made an effective contribution of 4,2%, (4) jointly physical fitness, work discipline and work motivation contributed 61,4% to the performance of UNNES Security members. Recommendations from this study are that efforts should be made to improve fitness physical, work discipline and work motivation UNNES Security together in order to improve the performance of Security Semarang State University.

Keywords: Physical Fitness, Discipline, Motivation, Performance

1 Introduction

Security s in this case are Police partners who carry out limited police functions, in the context of empowering independent self-security security as Police partners in carrying out tasks in special coordination, to increase legal awareness and improve security in their environment [1]. Safeguards as part of overall management, which involves the organizational structure, planning, responsibilities, implementation, procedures, processes and resources needed for the development of planning, winning, reviewing and maintaining security policies in a safe, efficient and productive manner [2].

Semarang State University as one of the leading LPTKs in Indonesia as stated in its mission; organize and develop education in educational and non-educational programs which are superior in view of conservation and international reputation. Supported by human resources totaling more than 1090 lecturers, and 32,913 students [3]. Comparison of the number of UNNES Security against Lecturers and Students is 1 person compared to 311 people [4].

UNNES security performance can be optimized if supported by good physical fitness in addition to other factors, in some previous studies physical fitness is a supporting factor for officers to carry out their duties optimally [5.6]. Physical fitness is a condition that reflects one's ability to perform tasks productively without experiencing significant exhaustion [7 – 9].

Discipline in this case as one of the factors has an influence on good performance [10]. Work discipline is an attitude and behavior that shows employee obedience to organizational regulations [11]. UNNES Security Guard requires work discipline to support the implementation of basic tasks and functions related to security in the work environment of UNNES. Work discipline directs members of UNNES security guards to obey the norms, code of ethics, statutory regulations and official regulations that apply in UNNES.

Another factor that also determines performance is work motivation [12]. Motivation is the strength that is in a person, which encourages behavior to take action [13]. There is a positive relationship between achievement motivation and work performance [14]. It is suspected that the emergence of good work motivation from members of UNNES security will result in good performance as well.

2 Methods

This type of research is quantitative correlational. The population in this study were 109 members of the Semarang State University Security Guard. The sampling technique is done by purposive sampling technique [15]. The sample size was 61 members of the UNNES security guard. The research instrument used for physical fitness was a safety test A with a 12-minute run (cooper test) and a safety test B with pull ups, sit ups, pushups, shuttle runs. Research instruments to determine the discipline, motivation and performance of UNNES Security Guard with questionnaire sheets, the use of instruments and measurement methods in more detail will be explained below;

2.1 Measurement of physical fitness

The tool used is the A and B Kesamaptaan test [16]. In the A Kesamaptaan test, members of the UNNES security carried out a 12-minute run which was then measured by the distance of his run, then adjusted to the existing norms. For Pull Up, sit up, push up, and shuttle run tests, the testee tests once and then is given the opportunity to carry out the test 3 times, then the best value is taken and adjusted to the existing test norms.

2.2 Measurement of discipline, motivation & performance

The instrument used in measuring discipline, motivation and performance is a questionnaire, which is a written statement that is used to obtain information from respondents in the sense of reports about their personalities, or things they know [17]. A valid and reliable instrument was obtained by first testing the questionnaire against members of the UNNES security as a non-sample population. The results of the calculation of the validity of the questionnaire on the variables of discipline, motivation, and performance on each of the questions from the respondents showed the value of $r_{count} > r_{table}$ (0.254) at a significance level of 5%, thus meaning the questionnaire was declared valid.

The research data is stated to be reliable if the instrument shows its consistency, in this case is the discipline, motivation, and performance of UNNES security guards. Based on the calculation results of the instrument analysis data the disciplinary variable shows the value of cronbach's alpha 0.794 greater than r_{table} that is 0.254, the motivational variable instrument shows the value of cronbach's alpha 0.901 greater than r_{table} that is 0.254, the performance variable instrument shows the value of cronbach's alpha 0.943 greater than r_{table} that is 0.254, this means the research instrument is declared reliable or in other words the instrument is of consistent value.

2.3 Data Analysis

Data from the results of measurements of physical fitness, discipline, motivation and performance results of UNNES security guards were analyzed univariately to obtain an overview of basic data with the aim of knowing the frequency distribution of all variables and facilitating further analysis. Then the bivariate analysis is performed using the Pearson correlation test which aims to determine the relationship between each variable. Data analysis in this study uses regression analysis techniques and correlation analysis. To get the right analytical results, testing the analysis requirements is needed in order to obtain the following confidence:

1) the data is normally distributed, so that the normality test is done, after the data is analyzed it is found that the Asymp value. Sig = 0.174 > 0.05 so the data is normally distributed. 2) between the independent variable data and the dependent variable has a linear relationship, so that the linearity test is performed. The results of data analysis found that; the value of linearity Y to X1 Sig = 0,000 < 0.05 This means that the linear relationship between Y and X1. Y linearity value of X2 Sig = 0,000 < 0.05 means there is a linear relationship between Y and X2. Y linearity value of X3 Sig = 0,000 < 0.05 which means there is a linear relationship between Y and X3. 3) the data is homogeneous, so the homogeneity test is carried out with the Levene test and based on the results of data analysis, the value for Y to X1 is Sig = 0.103 > 0.05. Y with respect to X2 Sig = 0.16 > 0.05. Y with respect to X3 Sig = 0.111 > 0.05 so that all variables are declared homogeneous.

3 Results and discussions

This study involved 61 members of UNNES security guards as research subjects, all of whom were male, according to the level of education there were 11 security guards who had just taken Pragada, 47 were Gada Pratama certified and 3 were Gada Madya certified. Based on their tenure, 14 people have 1-5 years of service, 23 with 6-10 years, 16 people with 11-15 years and 8 people with more than 15 years. General description of the characteristics of research subjects can be seen in table 1.

Table 1. Overview of Characteristics of Resarch Subjects

Characteristic	N	Range	Min- imum	Max- imum	Mean	Std. Deviation	Performance (Y)			
							Correlation	Sig.	Deter- mination	Sig.
Physical Fitness (X1)	61	42	38	80	65,46	8,026	3,06	0,003	0,108	0,000
Dicipline (X2)	61	39	60	99	80,98	9,806	3,667	0,001	0,463	0,000
Motivation (X3)	61	50	46	96	78,21	9,158	2,501	0,015	0,042	0,015
Simultaneously X1, X2, X3							30,173	,000 ^b	0,614	0,000

3.1 Correlation between physical fitness with performance

From the results of the t test in table 1 above, obtained t value = 3.060 with the value of Sig / P Value = 0.003 < 0.05 this means that there is a positive and significant relationship which means supporting the research hypothesis. Based on these results it means that there is a significant influence between physical fitness on the performance of UNNES security guards.

The results of the analysis indicate a positive relationship between physical fitness variables (X1) and performance variables (Y), this means that the physical fitness of UNNES security will be directly proportional to its performance. Means that if every member of UNNES security guard who has physical fitness in a good category, it will affect the performance improvement. In other words, the performance of UNNES security will increase along with the increase in physical fitness.

Effective contribution of physical fitness variables to performance variables can be determined by looking at how large the determinant coefficient (R Square Change). Based on table 1 above, the effective contribution of physical fitness to performance is R Square Change = 0.108 or an effective contribution of 10.8%.

3.2 Correlation between dicipline with performance

From the results of the t test in table 1, the calculated value of t = 3.667 with Sig / P Value = 0.001 < 0.05 means that there is a positive and significant relationship which means that supports the research hypothesis. Based on these results it means that there is a significant influence between discipline on the performance of UNNES

security guards. Effective contribution of disciplinary variables to performance variables can be determined by looking at how large the determinant coefficient (R Square Change) in table 1 above, the effective contribution of discipline to performance is R Square Change = 0.463 or an effective contribution of 46.3%.

3.3 Correlation between motivation with performance

From the results of the t test of motivation variables on performance in table 1 above, the value of t test = 2.501 with Sig / P Value = 0.015 < 0.05 means that there is a positive and significant relationship which means that supports the research hypothesis. Based on these results it means that there is a significant influence between discipline on the performance of UNNES security guards. Effective contribution of disciplinary variables to performance variables can be determined by looking at how large the determinant coefficient (R Square Change) in table 1 above, the effective contribution of discipline to performance is R Square Change = 0.042 or an effective contribution of 4.2%.

3.4 Correlation between physical fitness, discipline and motivation with performance

F value for simultaneous test where $F = 30,173$ with significance = 0,000 < 0.05 This means that the independent variable (X) simultaneously has an influence on the dependent variable (Y), can be seen in table 1. The effective contribution of the independent variable together with respect to dependent variable is R Square = 0.614, this means that the independent variable jointly contributes an effective contribution of 61.4% to the dependent variable (see in the table 1 above).

4 Conclusions

It can be concluded that physical fitness, discipline and work motivation have an influence on performance by making an effective contribution of 61.4%. While the remaining 36.6% is explained by other variables not examined in this study. It should be noted that there are other factors that also have a relationship between security guard performance. For this reason, it is hoped that in subsequent studies it will be able to explore more of these factors so that they will further enrich the findings of the study and broaden the treasury of science.

Acknowledgements

Thank you are conveyed to the UNNES Security Guards who have agreed to become research subjects. Researchers are also grateful to all leaders of UNNES who have given research permission, so that this research can run well.

References

- [1] Satpam LP. Kumpulan Materi Diklat Satpam Tingkat Gada Pratama Pola 232 Jam. Semarang: PT. Produktif Citra Sukses; 2016.
- [2] Satpam LP. Kumpulan Materi Diklat Satpam Tingkat Gada Utama Pola 232 Jam. Semarang: PT. Produktif Citra Sukses; 2017.

- [3] Simpeg UNNES, <http://simpeg.unnes.ac.id>, last accessed 18 June 2020.
- [4] UNNES Dalam Data, <http://unnes.ac.id>, last accessed 18 June 2020.
- [5] Sumaesah. Upaya Meningkatkan Kemampuan Kesamaptaaan Jasmani Personel Polrestabes Semarang Guna Mendukung Tugas Operasional Kepolisian. Sukabumi: Sekolah Inspektur Polisi Sukabumi; 2014.
- [6] Utami S. R. Hubungan Antara Status Gizi dan Tingkat Kebugaran Jasmani dengan Produktivitas Kerja Pada Tenaga Kerja Wanita Unit Spinning 1 Bagian Winding PT. Apac Inti Corpora Bawen. UJPH. 2014; 3(4):39–47.
- [7] Ismaryati. Tes dan Pengukuran Olahraga. Surakarta: Lembaga Pengembangan Pendidikan UNS dan UPT Penerbitan dan Percetakan UNS; 2006.
- [8] Dangsinia M., Rosmalina Y., Permaesih D., Herman S. Cara Praktis Pendugaan Tingkat Kesehatan Jasmani. Bul. Penel. Kes. 2001; 29(4):174–183.
- [9] Caspersen C. J., Powell K. E., Christenson, G. M. Physical activity, exercise, and physical fitness: definitions and distinctions for health-related research. Public Health Rep. 1985; 100(2):126–131.
- [10] Wulandari. Keterampilan Kerja, Kedisiplinan Kerja dan Efektifitas Komunikasi sebagai Prediktor Produktivitas Kerja Karyawan Bagian Produksi PT. Phillips Industries Batam. Jakarta: Universitas Terbuka; 2013.
- [11] Wungubelen, R. L. Pengaruh Kepemimpinan dan Disiplin Terhadap Kinerja Pegawai pada Inspektorat Kabupaten Flores Timur. Jakarta: Universitas Terbuka; 2013.
- [12] Mulyasa E. Penelitian Tindakan Kelas: Meningkatkan Produktivitas Sekolah. Bandung: Remaja Rosdakarya; 2009.
- [13] Widodo S. E. Manajemen Pengembangan Sumber Daya Manusia, 1st Ed. Yogyakarta: Pustaka Pelajar; 2015.
- [14] Mangkunegara A. P. Manajemen Sumber Daya Manusia. Bandung: PT. Remaja Rosdar Karya; 2005.
- [15] Arikunto S. Prosedur Penelitian Suatu Pendekatan Praktik. Jakarta: PT. Rhineka Cipta; 2013.
- [16] POLRI M. Pedoman Administrasi Ujian Kesamaptaaan Jasmani dan Beladiri Polri bagi Pegawai Negeri pada Polri. Jakarta: Markas Besar Kepolisian Negara Republik Indonesia; 2004.
- [17] Arikunto S. Dasar-Dasar Evaluasi Pendidikan. Jakarta: Bumi Aksara; 2013.

Peer Education: Increased Knowledge and Practice of HIV/AIDS Prevention in Female Sex Workers

Arulita Ika Fibriana¹, Muhammad Azinar²
 {arulita.ika.f@mail.unnes.ac.id¹, azinar.ikm@mail.unnes.ac.id²}

Universitas Negeri Semarang, Semarang, Indonesia^{1,2}

Abstract. Prevalence of HIV/AIDS is still high in all regions of Indonesia. One of them in Batang, Central Java. In 2019 there were 75 new cases of HIV/AIDS and 10 people had died. Most cases occur in Female Sex Workers (FSWs). Low knowledge and economic reasons cause the weak behavior of preventing HIV/AIDS transmission by FSWs in the localization. This research is pre experiment with one group pretest posttest design. Total 61 FSW samples were selected purposively. Chi square test to analyze the correlation between knowledge and practice of HIV/AIDS prevention and Mc Nemar test to analyze differences in knowledge of HIV/AIDS and Condom Negotiation between before and after the implementation of peer education. The results showed that knowledge was significantly related to HIV/AIDS prevention practices. The peer education model can significantly increase knowledge and skill of condom negotiation among FSWs in localization.

Keywords: HIV/AIDS, Knowledge, FSW

1 Introduction

Case of HIV/AIDS in Indonesia from time to time is always increasing. Likewise in Central Java Indonesia. HIV/AIDS cases in the last three years have also increased. This fact has made Central Java province ranked fifth in the largest number of AIDS cases nationally. Based on data, it is known that in Central Java an average of 10 new AIDS cases occur every day [1].

Batang Regency is one of the districts that has a high risk of transmission of HIV/AIDS because the region has the most localization sites in Central Java, namely 12 prostitution localizations spread along the Pantura street of Javanese island. AIDS cases in Batang continue to increase. Since 2007 to June 2018 there have been 1,039 cases of HIV/AIDS, 165 of which have died. Another fact is cumulative, many cases occur in housewives, 204 cases [2].

In the past year, 75 new cases of HIV/AIDS have been found in the Batang district and 10 people have died. Data from the Batang AIDS Commission stated that the

HIV/AIDS cases in Batang in the past year were dominated by women (63%) and mostly came from Female Sex Workers (FSWs). FSWs are the group that has the biggest risk factor due to sexual behavior that changes partners [2]. This fact shows that HIV/AIDS is increasingly worrying both in quantitatively and qualitatively.

Banyuputih sub-district is the region with the highest HIV/AIDS cases in Batang, which is 22 cases, followed by Bandar district with 20 cases and Gringsing 16 cases [2]. This is indicated because the region has the most places of prostitution localization in Batang, namely 3 localizations and some hidden localization in the form of cafes and karaoke venues [2].

The data shows that FSW are a high-risk group that is infected and also transmits HIV/AIDS. In Indonesia, it is predicted that more than 50% of FSW suffer from sexually transmitted diseases. This is exacerbated by the behavior of female sex workers who do not pay attention to their own health status. Most FSW do not want to do health checks and seek information related to their health status due to economic reasons and negative stigma. They prefer to buy their own medicines, including using antibiotics without consulting health workers.

Knowledge about HIV / AIDS is still low among FSWs and economic reasons have been the main cause of the low efforts to prevent transmission among them. The unavailability of comprehensive and sustainable information in the localization causes FSW to not fully know the information about the spread and ways to prevent the disease. Behavioral change that focuses on increasing knowledge and health beliefs, developing skills, and supporting the social environment can be effective strategies to reducing HIV/AIDS risk behaviors among female sex workers.

Peer education is a form of behavior change communication strategy based on peer groups. Peer education is a program based on the reason that peers have a strong influence on individual behavior. Peer educators are assumed to have a level of trust and comfort with their peers which allows a more open discussion about sensitive topics [3]. Peer education programs might empower both educators and target groups by creating a sense of solidarity and collective action [4]. This study aims to analyze the relationship between knowledge and practice of HIV/AIDS prevention and analyze differences in knowledge and skills in condom negotiation between before and after FSW following a peer education program in localization.

2 Method

This is pre experiment research with one group pretest posttest design. The population of this study was the FSW in the Panundan Banyuputih localization in Batang regency. The research sample was taken by purposive sampling with the condition that they have lived in the localization for at least 2 months, can read and write, take part in peer education at least 4 times from the total meeting of 6 times. Based on these requirements, the eligible samples were 61 FSW. Research data collection using a questionnaire.

Data analysis used the Chi square test to analyze the relationship between knowledge and HIV/AIDS prevention practices and Mc Nemar test to analyze differences in HIV/AIDS knowledge between before and after the implementation of peer

education. This research protocol has been reviewed and approved by the Ethics Commission of Health Research Universitas Negeri Semarang with Ethical Clearance number 137/KEPK/EC/2019.

3 Results and discussions

From 61 FSW is known that their average age is 28 years. The youngest is 20 years old and the oldest 47 years old. The following is an overview of the level of education, marital status and length of service as FSW in the Panundan Localization in Banyuputih, Batang district.

Table 1. Female Sex Worker Characteristic

Characteristic	Frequency	%
Education Level		
No School	2	3,3
Elementary School	39	63,9
Junior High School	18	29,5
Senior High School	2	3,3
Marriage Status		
Single	5	8,2
Merried	13	21,3
Widowed / divorce	43	70,5
Length of Work as FSW		
<1 year	16	26,2
1-5 years	39	63,9
6-10 years	4	6,6
>10 years	2	3,3

Table 1 above shows that the majority of FSWs with elementary school education are 63.9%, and 29.5% of junior high schools, and there are 2 people (3.3%) of senior high school graduates. Judging from the marital status, the majority of FSWs were widowed/divorced at 70.5%. However, there were 21.3% of FSWs who were still married and there were 5 people (8.2%) FSWs who were not married. Based on the length of work as FSW, the majority of FSW who have worked as FSW are between 1 and 5 years. However, there were 16 FSW (26.2%) who took the profession as new FSW (less than a year).

Table 2. The correlation between knowledge and HIV / AIDS prevention practices

Variabel	HIV/AIDS prevention practices		<i>p value</i>
	Not good	Good	
Knowledge			
Not good	31 (96,9%)	1 (3,1%)	0,010
Good	21 (72,4%)	8 (27,6%)	

Table 2 shows there is correlation significantly between knowledge and HIV/AIDS prevention practices (p value 0.010). FSW with good knowledge have a tendency to practice HIV/AIDS prevention better than those with low knowledge. This research is also known that there are still many FSWs who have poor knowledge (52.45%).

Table 3. Knowledge Difference between Before and After the Implementation of Peer Education in Localization

Variable	Knowledge (<i>Post-test</i>)		<i>p value</i>
	not good	good	
Knowledge (<i>Pre-test</i>)			
not good	16 (26,2%)	16 (26,2%)	0,000034
good	0 (0,0%)	29 (47,5%)	
	Condom Negotiation (<i>Post-test</i>)		
	not always	always	
Condom Negotiation (<i>Pre-test</i>)			
not good	22 (36,1%)	26 (42,6%)	0,00000002
good	0 (0,0%)	13 (21,3%)	

The results (table 3) shows there are differences in FSW knowledge between before and after the application of the Peer Education model in Localization. FSW who before applying the Peer Education model who had poor knowledge, after following the Peer Education model their knowledge became better. This shows a significant increase in knowledge (p value 0,000034) and skill of Condom Negotiation (p value 0,00000002) after FSW joined Peer Education.

Peer Education is a form of behavioral change communication intervention aimed at increasing the practice of preventing HIV/AIDS transmission through increasing knowledge about HIV/AIDS among FSWs in localization. Peer education actively involves the role of FSW, namely as peer educators, peer counselors and at the same time as targets of peer education. The implementation of peer education in this localization has been able to increase FSW's knowledge in localization. Peer Education has also indirectly provided awareness and motivation on the importance of using condoms in risky sexual behavior, as well as regular STI screening and Voluntary Counselling and Testing HIV. The results of this study are in line that health education provided to the Commercial Sex Workers community has an influence on increasing the knowledge and attitudes of Sex Workers communities [5]. Another study, health education can improve knowledge and attitudes in controlling HIV/AIDS [6].

Support among fellow FSWs in localization to remind one another and support one another in preventing transmission of HIV/AIDS has affected the better awareness of FSWs in preventing HIV/AIDS transmission by increasing condom use, in-

creasing FSW participation in STI screening and participating in VCT. These results are consistent with research that states there is health education to improve attitudes and awareness in controlling HIV/AIDS [6].

The reason of FSW's clients and FSW are not to use condoms is the lack of information about the importance of condoms as a prevention of transmission of sexually transmitted diseases including HIV/AIDS. The use of condoms is felt unpleasant, uncomfortable, and can reduce pleasure in sexual activity. Therefore, FSW need to be empowered to not only reject the unprotected sex, but also to be able to motivate the clients for using condoms. These skills can be improved through continuous intensive peer education interventions. This is in accordance which states that condom intervention and promotion must also be able to overcome the factors that affect the ability of FSW to negotiation of condom use [7].

This research also in line with those stating that peer education has produced positive changes in comprehensive knowledge related to HIV in students and shows a better interest in taking HIV tests [8]. This can be explained by assuming that peer educators are reliable source of information about HIV/AIDS for adolescents. This research is in line with research on the influence of peer education in other countries [9,10,11].

Peer education can significantly increase knowledge about HIV [12]. Peer education is effectively to increasing knowledge, attitudes, and prevention practices against HIV/AIDS among adolescents in schools. Program for education about HIV/AIDS must therefore be designed to target this group taking into account their characteristics. Program for education about HIV/AIDS must therefore be designed to Female sex Worker by their characteristics [13].

4 Conclusions

Knowledge was significantly related to HIV/AIDS prevention practices. The implementation of peer education in the localization is effective in increasing knowledge about HIV/AIDS in FSWs. There are differences in FSW knowledge between before and after the application of the Peer Education model in Localization. FSW who before applying the Peer Education model who had poor knowledge, after following the Peer Education model their knowledge and Condom Negotiation became better.

References

- [1] Director General of P2PL, Ministry of Health. Statistics on HIV/AIDS Cases in Indonesia Trimester IV of 2018. Jakarta: Ministry of Health of the Republic of Indonesia; 2018
- [2] Central Java AIDS Commission. HIV / AIDS data in Central Java. Semarang: Central Java AIDS Commission; 2019
- [3] Campbell C, MacPhail C. Peer education, gender and the development of critical consciousness: Participatory HIV prevention by South African youth. *Social Science and Medicine*. 2002; 55(2):331–345.

- [4] Strange V, Forrest S, Oakley A. Peer-led sex education--characteristics of peer educators and their perceptions of the impact on them of participation in a peer education programme. *Health Educ Res.* 2002;17(3):327-337.
- [5] Dewi, N.S. Effects of Health Education on Changes in Knowledge and Attitudes in HIV and AIDS Prevention in Commercial Sex Workers. *Media Ners.* 2008; 2(1): 1-44.
- [6] Purnomo K.I., Bhisma M dan Putu S. Comparison of the Effects of Peer Education Methods and Lecture Methods on Knowledge and Attitudes towards HIV/AIDS Control in Sports and Health Faculty Students. *Jurnal Magister Kedokteran Keluarga Universitas Pendidikan Ganesha;* 2013. 1(1): 49-56.
- [7] Bharat, Shalini; et al. Are female sex workers able to negotiate condom use with male clients? The case of mobile FSWs in four high HIV prevalence states of India. *PloS ONE.* 2013; 8(6).
- [8] Takele Menna, Ahmed Ali, and Alemayehu Worku. Effects of peer education intervention on HIV/AIDS related sexual behaviors of secondary school students in Addis Ababa, Ethiopia: a quasi-experimental study. *Reprod Health.* 2015; 12: 84.
- [9] Gallant M, Maticka-Tyndale E. School-based HIV prevention programs for African youth. *SocSci Med.* 2004; 58:1337-51.
- [10] Medley A, Kennedy C, O'Reilly K, Sweat M. Effectiveness of Peer Education Interventions for HIV Prevention in Developing Countries: A Systematic Review and Meta-Analysis. *AIDS Educ Prev.* 2009; 21(3):181-206.
- [11] Kindeberg T, Christensson B. Changing Swedish students' attitudes in relation to the AIDS epidemic. *Health Educ Res.* 1994; 9:171-81.
- [12] Amy Medley, Caitlin Kennedy, Kevin O'Reilly, and Michael Sweat,. 2009. Effectiveness of Peer Education Interventions for HIV Prevention in Developing Countries: A Systematic Review and Meta-Analysis. *AIDS Educ Prev.* 2009; 21(3): 181-206.
- [13] Adeleye Abiodun Adeomi, Oluwatosin Adediran Adeoye, Esther Olufunmilayo Asekun-Olarinmoye, Olugbemiga Lanre Abodunrin, Adenike Iyanuoluwa Olugbenga-Bello, and Adedayo Olukemi Sabageh. Evaluation of the Effectiveness of Peer Education in Improving HIV Knowledge, Attitude, and Sexual Behaviours among In-School Adolescents in Osun State, Nigeria. *AIDS Research and Treatment.* 2014.

Analysis of Lymphatic Filariasis Case Distribution for Preparing Environmental Based Elimination Strategy in Brebes Regency, Indonesia

Arum Siwiendrayanti¹, Eram Tunggul Pawenang², Yuni Wijayanti³, Widya Hary Cahyati⁴
{a_shiwi@mail.unnes.ac.id¹, eramtepe@mail.unnes.ac.id², yuniwija@mail.unnes.ac.id³}

Universitas Negeri Semarang, Semarang, Indonesia^{1,2,3,4}

Abstract. Brebes Regency is a new endemic area for lymphatic filariasis in Central Java Province, Indonesia, which has farming area and coastal area. This study aimed to analyze the lymphatic filariasis cases distribution in Brebes Regency for preparing environmental strategy of elimination. This was a descriptive study with spatial and documentary approach. The scope of location covered all subdistricts. The lymphatic filariasis case distribution was analyzed spatially. The analysis of zero case subdistricts vulnerability and environmental control preparation were composed based on previous studies and secondary data. The result showed that most cases were located on farming area. The zero case subdistricts were vulnerable. Three concepts of environmental control approaches were composed. It was concluded that elimination program in Brebes Regency should prior the farming areas. It was a unique finding that the previous studies told the contrary that coastal areas were more vulnerable for lymphatic filariasis.

Keywords: lymphatic filariasis, case distribution, filariasis endemic area, coastal area, farming area.

1 Introduction

Lymphatic filariasis or elephantiasis is caused by parasitic infections classified as nematodes from the *Filariodidea* family. There are three types of filaria worms namely *Wuchereria bancrofti*, *Brugia malayi*, and *Brugia timori*. Lymphatic filariasis is spread by various mosquitoes like *Culex*, *Aedes*, *Anopheles*, *Armigeres*, and *Mansonia*. [1,2] World Health Organization (WHO) had launched the elimination of lymphatic filariasis program which was targeted to achieve it in 2020. But especially in Central Java Province, Indonesia, in the last two years the number of regencies / cities that have endemic filariasis had increased from 2 to 9. The strategy from WHO in eliminating lymphatic filariasis were by mass drug administration, environmental control, and management of clinical cases of lymphatic filariasis. Lymphatic filariasis elimination strategies from WHO faced different challenges in each country that applies them. Considering local conditions is needed in

implementing the elimination strategies, especially in environmental control aspect where conditions can be very different in each region.[1]

Lymphatic filariasis endemic area is an area which has more than 1% percentage of microfilaria positive blood sample. Central Java Province, Indonesia, before 2017 only had 2 endemic areas, namely Pekalongan Regency and Pekalongan City. After 2017, Central Java Province had 9 regencies/cities as lymphatic filariasis endemic areas, namely Pekalongan City, Pekalongan Regency, Brebes Regency, Wonosobo Regency, Semarang Regency, Grobogan Regency, Blora Regency, Pati Regency and Demak Regency. The highest number of new case findings in Central Java occurred in Brebes Regency. The number of lymphatic filariasis case in Brebes Regency had increased from year to year. Lymphatic filariasis cases in 2016 in Brebes Regency numbered 25, increased to 54 in 2017, and increased to 65 in 2018.

Brebes Regency has unique condition in space. It has combination between farming area and coastal area. Brebes Regency is famous because of its red onion commodity which dominate its farming areas. Besides red onion, Brebes Regency also has rice, corn, potato, and various fruits commodities. Brebes Regency is also known as salted eggs producer. Therefore, duck farming is also often found there. The other livestock in Brebes Regency are cow, buffalo, goats, and sheep. Brebes has several subdistricts bordering the seashore which are famous with its mangrove tourism track. Those all have potency to be mosquito breeding places. Slum farming areas and puddles can be mosquito breeding and resting places in farming areas.[3–7] Likewise, slum coastal settlements and tidal flood can be mosquito breeding and resting places in coastal areas.[8–14] This study aimed to analyze the distribution of lymphatic filariasis cases in Brebes Regency for preparing suitable environmental based strategy for lymphatic filariasis elimination.

2 Methods

This was a descriptive study with spatial and documentary approach. The scope of location covered all subdistricts in Brebes Regency. Lymphatic filariasis case data were collected from Health Office of Brebes Regency. The data were confirmed to each Public Health Center (*Puskemas*) in Brebes Regency. The lymphatic filariasis case was analyzed spatially to determine its distribution in farming area and coastal area. The number of lymphatic filariasis case was written down on each subdistrict on the Brebes Regency map taken from id.wp-Wic2020 (*Lisensi Bebas GNU*, Version 1.2). The data for analyzing the vulnerability of zero case subdistricts were collected from Statistic Central Bureau of Brebes Regency, Central Java Environment Agency, and Agricultural Office of Brebes Regency with documentary approach. The environmental based elimination strategy preparation was composed based on previous studies and secondary data from Statistic Central Bureau of Brebes Regency, Central Java Environment Agency, and Agricultural Office of Brebes Regency.

3 Results and Discussions

3.1 Spatially Distribution of Lymphatic Filariasis Case in Brebes Regency

The most cases of lymphatic filariasis were located on Ketanggungan Subdistrict. It is a farming area or non-coastal area. Ketanggungan Subdistrict is one of the red onion farming centers in Brebes Regency.[15] Red onion farming area is wetland farm or agricultural land with pooled water. This pooled water of red onion farmland had the potential to become a breeding place for mosquitoes.[16] Ketanggungan Subdistrict also had the second highest of cow livestock population. Several studies proofed the correlation between the presence of cattle pens and lymphatic filariasis case.[10,16,17] The subdistrict with second highest number of lymphatic filariasis cases is Paguyangan Subdistrict which is also an agricultural or non-coastal area. Agricultural commodities from Paguyangan Subdistrict are rice, cassava, corn, and sweet potatoes. Rice field area is wetland farm or agricultural land with pooled water. It could be a breeding place for mosquitoes.[16] The cassava, corn, and sweet potato farming areas were dry land farms or plantation lands without pooled water. Plantation land with a lot of plants and shrubs could also be a resting place for mosquitoes.[3,10] Paguyangan Subdistrict had the highest position in poultry eggs and cow milk. It was closely related to raising cattle and poultry. Duck farming needed pooled water scape which could be breeding place for mosquitoes. Cattle pen could be resting place for mosquitoes and previously proofed related to lymphatic filariasis case by several studies.[10,16,17]

Subdistrict with the highest number of lymphatic filariasis cases in Brebes Regency was not in the coastal area. It was a different finding from some previous studies. Previous studies had found that lymphatic filariasis cases were more prevalent in coastal areas. Slums and tidal flood were strongly suspected of being mosquito breeding and resting places. The limited socioeconomic capacity of coastal settlers also made it more difficult for improving environmental conditions in coastal areas.[8–10] Several studies had correlated mangrove ecosystem condition with mosquito density. Those studies explained that undisturbed mangrove ecosystem would become a habitat for mosquitoes so that mosquitoes did not fly towards settlement areas. This was indicated by the higher mosquito density in the mangrove area and the lower mosquito density in the settlement area. The condition of mangrove ecosystem that were disturbed due to human activities caused mosquitoes to lose their habitat so that they fly towards the settlement area. This resulted in a higher density of mosquitoes in the settlement. [11,14,18,19] Several other studies linking the condition of mangrove ecosystems with the spread of mosquito-borne diseases. When the mangrove ecosystem was disturbed, mosquitoes flied towards the settlement. The higher density of mosquitoes in settlements increased the risk of transmitting mosquito-borne diseases. De Souza's et al. (2012) research showed that mosquitoes around disturbed mangrove areas were the type of mosquito that spreads disease. [20–23] Data from the Central Java Environment Agency showed that Brebes Regency had good mangrove quality and quantity in space. It could keep mosquito population in the mangrove area and not fly to the settlement. However, further research is needed to confirm this.



Fig. 1. Distribution of lymphatic filariasis case number in Brebes Regency. [Modified from id.wp-Wic2020 (*Lisensi Bebas GNU*, Version 1.2)]

3.2 The Vulnerability of the Zero Case Subdistricts in Brebes Regency

There were 2 subdistricts which did not have lymphatic filariasis cases, namely Kersana Subdistrict and Bumiayu Subdistrict. Both of them should be prevented from lymphatic filariasis transmission. Table 1 detailed aspects that illustrate the vulnerability of the two subdistricts to transmission of filariasis.

Kersana Subdistrict was bordered with Ketanggungan Subdistrict which had the highest number of lymphatic filariasis case and also bordered with other subdistricts which had lymphatic filariasis cases. It would increase the risk of lymphatic filariasis transmission because mosquitoes could fly to the nearest area. This concern was reinforced by the existence of environmental conditions that support mosquito breeding and resting. Kersana Subdistrict had 45.5 Ha dry land farm and also 175 cows and buffaloes. Dry land farm with a lot of plants and shrubs could also be a resting place for mosquitoes.[3,10] Presence of cattle pens would increase the risk of lymphatic filariasis because the cattle would attract the mosquito and the cattle pens were suitable for mosquito resting place.[10,16,17] Kersana Subdistrict also had 3,020 Ha wetland farm consisted of paddy field and red onion farm. The pooled water on wetland farm was suitable for mosquitoes breeding place.[16]

Bumiayu Subdistrict was bordered with Paguyangan Subdistrict which had the second highest number of lymphatic filariasis case and also bordered with other subdistricts which had lymphatic filariasis cases. It would increase the risk of lymphatic filariasis transmission because mosquitoes could fly to the nearest area. This concern was reinforced by the existence of environmental conditions that support mosquito breeding and resting. Bumiayu Subdistrict had 4,163 Ha dry land farm and also 1,411 cows and buffaloes. Dry land farm with a lot of plants and shrubs could also be a resting place for mosquitoes.[3,10] Presence of cattle pens would increase the risk of lymphatic filariasis because the cattle would attract the mosquito and the cattle pens were suitable for mosquito resting place.[10,16,17] Bumiayu Subdistrict also had 12,076 Ha wetland farm consisted of paddy

field and red onion farm. The pooled water on wetland farm was suitable for mosquitoes breeding place.[16]

Table 1. The vulnerability of the zero lymphatic filariasis case subdistricts in Brebes Regency.

Subdistrict	Risk factors	Protective factors
Kersana	Bordered with the highest cases subdistrict (Ketanggungan). Surrounded by other districts that had cases. Has 2,154 Ha paddy field area. Has 866 Ha red onion farm. Has 175 cows and buffaloes. Has 45.5 Ha dry land farm.	The highest usage of pesticides.
Bumiayu	Bordered with the second highest cases subdistrict (Panggung). Surrounded by other districts that had cases. Has 7,913 Ha paddy field area. Has 1,411 cows and buffaloes. Has 4,163 Ha dry land farm.	Has no red onion farm.

Both Kersana Subdistrict and Bumiayu Subdistrict had many risk factors of lymphatic filariasis transmission. They were surrounded by the other subdistricts which had lymphatic filariasis cases and had potential environment conditions which were suitable for mosquito breeding and resting. Bumiayu Subdistrict has a protection factor in the form of the absence of shallot farmland where onion farmland is at risk of becoming a breeding place for mosquitoes because there is standing water. However, Bumiayu Subdistrict had a wider total of wetland and dryland farming areas than Kersana Subdistrict. The number of cattle in Bumiayu Subdistrict was also higher than Kersana Subdistrict. In addition, Kersana Subdistrict was recorded as the subdistrict with the highest level of pesticide use in Brebes Regency. Excessive use of pesticides could kill mosquito larvae and adult mosquitoes. This would reduce the risk of lymphatic filariasis transmission, even though the overuse of pesticide could endanger the environment and human health.[24–27] It could be stated that both Kersana Subdistrict and Bumiayu Subdistrict are vulnerable for lymphatic filariasis transmission, but Bumiayu Subdistrict is more vulnerable.

3.3 The Concept of Environmental Based Elimination Strategy in Brebes Regency

There were three concepts composed based on the risk and protective factors explained previously. They should be implemented in farming area, coastal area, and settlement which were detailed in Table 2.

Table 2. The Concept of Environmental Based Elimination Strategy in Brebes Regency.

Area	Environmental Prevention
Farming area	For wetland farming (paddy field and red onion farm): Implementing Minapadi System where fish are released into pooled water on agricultural wetlands. For dry land farming (field of potato, corns, etc.): Keeping the field tidy without herbages and shrubs and keeping enough space between agricultural crops.
Coastal area	Maintaining the sustainability of mangrove ecosystems.
Settlement area	Keeping cattle pens not connected directly with the dwelling house. Installing mosquito wire net to house vents.

The application of the Minapadi system is expected to prevent mosquito breeding. Fish can eat mosquito larvae. The Minapadi system has long been known in Indonesia by placing fish in agricultural wetlands so that beside harvesting crops it can also harvest fish. However, there are some obstacles in the application of Minapadi system, including the phenomenon of fish theft from land and contamination of pesticides that will poison the fish. If this Minapadi is focused on controlling the transmission of lymphatic filariasis, it is better to choose larvivorous fish than production fish so that the fish is not stolen. Regarding the use of pesticides, it is recommended to use them in wisely and it would be better to implement organic farming system without pesticides. Organic farming without pesticides is safer for the environment and human health.[16,28–30] Shrubs and herbages could be resting places for mosquitoes. Keeping the dry land farm tidy and keeping enough space between agricultural crops would reduce its probability to be resting places for mosquitoes.[4,10,31]

The condition of mangrove ecosystem that were disturbed due to human activities caused mosquitoes to lose their habitat so that they fly towards the settlement area. This resulted in a higher density of mosquitoes in the settlement. Maintaining the sustainability of mangrove ecosystems would result in many benefits, not only preventing lymphatic filaria transmission but also protecting coastal area from abrasion and severe impact of disaster. [11,14,18,19]

The villagers used to place the cattle pens close to and even connected with their houses for reasons of avoiding cattle theft and also limited land. Whereas several studies had proven that close cattle pens to house will increase the risk of lymphatic filariasis transmission because livestock and their pens would attract mosquitoes. If it is not possible to move away the cattle pens from the house, efforts must be made to ensure that the cattle pens are not integrated with the house. Even if it is integrated with the house, it must be separated with a permanent wall without any hollows. Installing a mosquito wire net to house vents will prevent mosquitoes from entering the house. Filariasis is transmitted through mosquito bites. Preventing the entry of mosquitoes into the house will reduce the risk of transmission of filariasis. It should be implemented settlement areas both on farming and coastal areas.[3,16,17]

4 Conclusions

Conclusion of this study was that the greatest number of lymphatic filariasis cases were spatially located on farming area subdistricts. It was a unique finding that the previous studies told the contrary that coastal areas were more vulnerable for lymphatic filariasis. Further studies are needed to explain both specific risk factor of lymphatic filariasis in Brebes Regency's farming area and protective factor of it in Brebes Regency's coastal areas. They were two zero case subdistricts in Brebes Regency which needed to be prevented from lymphatic filariasis transmission. Both of them were vulnerable for lymphatic filariasis transmission, but Bumiayu Subdistrict was more vulnerable. Three concepts of environmental control approaches were composed. These should be implemented in farming areas, coastal areas, and settlement areas both on farming and coastal areas.

Acknowledgments

We gratefully thank the Faculty of Sport Science of Universitas Negeri Semarang for funding this study through Flagship College Program (*Penelitian Unggulan Perguruan Tinggi*) 2020.

References

- [1] World Health Organization. Global Programme to Eliminate Lymphatic Filariasis: Managing Morbidity and Preventing Disability. World Heal. Organ. Geneva-Switzerland: Department of Control of Neglected Tropical Diseases (NTD) World Health Organization; 2013.
- [2] Eldridge BF, Edman JD, editors. Medical Entomology--A Textbook in Public Health and Veterinary Problems Caused by Arthropods. Revised Ed. Dordrecht: Springer Science+Business Media, B.V.; 2004.
- [3] Siwiendrayanti A, Pawenang ET, Indarjo S. Spatial analysis and behavior evaluation to identify differentiating factors of filariasis endemic status. *Adv Sci Lett.* 2017;
- [4] Khikmah N, Pawenang ET. Review of Environmental Aspects and Community Behavior in the Determination of Filariasis Risk Vulnerability Zone. *Unnes J Public Heal.* 2018;7:38–49.
- [5] Okon OE, Iboh CI, Opara KN. Bancroftian filariasis among the Mbembe people of Cross River state, Nigeria. *J Vector Borne Dis.* 2010;47:91–6.
- [6] Upadhyayula SM, Mutheneni SR, Kadiri MR, Kumaraswamy S, Nagalla B. A cohort study of lymphatic filariasis on socio economic conditions in Andhra Pradesh, India. *PLoS One.* 2012;7:1–8.
- [7] Mutheneni SR, Upadhyayula SM, Kumaraswamy S, Kadiri MR, Nagalla B. Influence of socio-economic aspects on lymphatic filariasis: A case-control study in andhra pradesh, India. *J Vector Borne Dis.* 2016;53:272–8.
- [8] Nurjazuli, Santjaka A. Potential Sources of Transmission and Distribution of Lymphatic Filariasis in Semarang City, Central Java, Indonesia. *Unnes J Public Heal.* 2020;9:43–9.
- [9] Nurjazuli N, Setiani O, Lubis R. Analysis of Lymphatic Filariasis Transmission Potential in Pekalongan City, Central Java, Indonesia. *Asian J Epidemiol.* 2018;11:20–5.
- [10] Siwiendrayanti A, Pawenang ET, Indarjo S, Hikmah IH. Filariasis Vulnerability Zonation Based on Environmental and Behavioural Aspects in Pekalongan City, Indonesia Filariasis Vulnerability Zonation Based on Environmental and Behavioural Aspects in Pekalongan City, Indonesia. *IOP Conf Ser Earth Environ Sci.* IOP Publishing; 2020. p. 448 012016.

- [11] Ismail TNST, Kassim NFA, Rahman AA, Yahya K, Webb CE. Day biting habits of mosquitoes associated with mangrove forests in Kedah, Malaysia. *Trop Med Infect Dis.* 2018;3:1–8.
- [12] Siwiendrayanti A, Pawenang ET, Windraswara R, Wijayanti Y. Sequential Neighborhood Filariasis Transmission in Coastal Areas of Demak Regency, Indonesia. *Adv Soc Sci Educ Humanit Res.* Semarang: Atlantis Press; 2019. p. 241–5.
- [13] Claflin SB, Webb CE. Surrounding land use significantly influences adult mosquito abundance and species richness in urban mangroves. *Wetl Ecol Manag.* 2017;25:331–44.
- [14] de Souza AS, Couri MS, Florindo L. The Impact of Industrial Anthropization on Mosquito (Diptera, Culicidae) Communities in Mangrove Areas of Guanabara Bay (Rio de Janeiro, Brazil). *Neotrop Entomol.* 2012;41:68–73.
- [15] BPS Statistics of Brebes Regency. Brebes Regency in Figures 2020. Brebes: BPS Statistics of Brebes Regency; 2020.
- [16] Juwita F, Cahyati WH, Yuniastuti A. Risk Factors of Filariasis in Brebes Regency. *Public Heal Perspect J.* 2020;5:137–46.
- [17] Syuhada Y, Nurjazuli, W NE. Study Of Environmental And Behavioral As Risk Factor Of Filariasis In District Of Buaran And Tirto Pekalo. *Kesehat Lingkung Indones.* 2012;11:95–101.
- [18] Masela DF. Pengaruh Struktur dan Komposisi Mangrove bagi Kerapatan Nyamuk di Desa Kopi dan Desa Minanga Kecamatan Bintauna. Daniel F. Masela/ 080317009. *COCOS.* 2012;1:1–8.
- [19] Kojongian G, Pijoh VD, Bernadus JBB. Survei Nyamuk Anopheles spp di Pesisir Selat Lembeh Kota Bitung. *J Kedokt Klin.* 2016;1:37–45.
- [20] Putra AK, Bakri S, Kurniawan B. Peranan Ekosistem Hutan Mangrove pada Imunitas terhadap Malaria: Studi di Kecamatan Labuhan Meringgai Kabupaten Lampung Timur. *J Sylva Lestari.* 2015;3:67–78.
- [21] Wigaty L, Bakri S, Santoso T, Wulan S. R. Wardani D. Pengaruh Perubahan Penggunaan Lahan Terhadap Angka Kesakitan Malaria: Studi Di Provinsi Lampung. *J Sylva Lestari.* 2016;4:1–10.
- [22] Palaniyandi M, Anand P, Maniyosai R. Spatial cognition : a geospatial analysis of vector borne disease transmission and the environment, using remote sensing and GIS. *Int J Mosq Res IJMR.* 2014;1:39–54.
- [23] Ramasamy R, Surendran SN. Global climate change and its potential impact on disease transmission by salinity-tolerant mosquito vectors in coastal zones. *Front. Physiol.* 2012.
- [24] Kibuthu TW, Njenga SM, Mbugua AK, Muturi EJ. Agricultural chemicals: Life changer for mosquito vectors in agricultural landscapes? *Parasites and Vectors. Parasites & Vectors;* 2016;9:1–9.
- [25] Siwiendrayanti A, W NE. Hubungan Riwayat Pajanan Pestisida Dengan Kejadian Gangguan Fungsi Hati (Studi pada Wanita Usia Subur di Kecamatan Kersana Kabupaten Brebes) Association Between Pesticides Exposure and Liver Disfunction (Study on women childbearing-age at Kecamatan Ker. *J Kesehat Lingkung Indones.* 2012;11:9–14.
- [26] Emidi B, Kisinza WN, Mmbando BP, Malima R, Mosha FW. Effect of physicochemical parameters on Anopheles and Culex mosquito larvae abundance in different breeding sites in a rural setting of Muheza, Tanzania. *Parasites and Vectors. Parasites & Vectors;* 2017;10:1–12.
- [27] Gardner AM, Anderson TK, Hamer GL, Johnson DE, Varela KE, Walker ED, et al. Terrestrial vegetation and aquatic chemistry influence larval mosquito abundance in catch basins, Chicago, USA. *Parasites and Vectors.* 2013;6:1–11.
- [28] Sinka ME, Bangs MJ, Manguin S, Chareonviriyaphap T, Patil AP, Temperley WH, et al. The dominant anopheles vectors of human malaria in the Asia-Pacific region: Occurrence data, distribution maps and bionomic précis. *Parasites and Vectors.* 2011;4.
- [29] El-Zeiny A, El-Hefni A, Sowilem M. Geospatial techniques for environmental modeling of mosquito breeding habitats at Suez Canal Zone, Egypt. *Egypt J Remote Sens Sp Sci. National Authority for Remote Sensing and Space Sciences;* 2017;20:283–93.

- [30] Bond JG, Casas-Martínez M, Quiroz-Martínez H, Novelo-Gutiérrez R, Marina CF, Ulloa A, et al. Diversity of mosquitoes and the aquatic insects associated with their oviposition sites along the Pacific coast of Mexico. *Parasites and Vectors*. 2014;7.
- [31] Wulandhari SA, Pawenang ET. Analisis Spasial Aspek Kesehatan Lingkungan Dengan Kejadian Filariasis Di Kota Pekalongan. *Unnes J Public Heal*. 2017;6:59–67.

Policies and Strategies for Reducing Stunting through The Community Empowerment Model

Bambang Budi Raharjo¹, Sofwan Indarjo², Efa Nugroho³
 {bambangbr@mail.unnes.ac.id¹, sofwan_indarjo@yahoo.co.id²,
 efa.nugroho@mail.unnes.ac.id³}

Universitas Negeri Semarang, Semarang, Indonesia^{1,2,3}

Abstract. WHO (World Health Organization) has set a maximum limit of stunting sufferers that is 20% of the total number of children under five. In Indonesia, the percentage of stunting toddlers in 2018 according to the results of the Basic Health Research (Riset Kesehatan Dasar) was 30.8% even reaching 37.2% in 2013. The number of stunting in Demak in 2013 was 50.28% (50,780 toddlers). Various efforts and programs have been carried out but have not reached maximum results, in 2019 the incidence of stunting in the Demak Regency is still 50.23% (48,829 children under five years old) and 4.29% (6,129 children under five years old) potentially stunting. The purpose of this study was to determine the policies and strategies for stunting prevention through community empowerment models. This research used a systematic review design. Articles were obtained from various sources and then filtered to get the core articles to be analyzed. One of the results of the research is that the BKKBN has developed the Kampung KB program. The spirit of forming and establishing Kampung KB throughout the archipelago has resulted in hundreds of Kampung KB. The presence of Kampung KB aimed to improve the quality of life of the community at the village level or equivalent through the Bangsa Kencana program and the development of other sectors to create quality small families including on the family health side. It is hoped that the influence of the optimization of the Kampung KB as a strategy for the acceleration of stunting countermeasures.

Keywords: Stunting, Policy, Community Empowerment.

1 Introduction

Stunting or dwarf disease is one of the nutritional problems experienced by toddlers, where toddlers experience a condition of failure to grow due to chronic malnutrition so that the toddler is too short for his age [1]. Stunting is a continuation process that does not happen suddenly [2]. Broadly speaking, stunting is caused by a lack of

nutritional intake in a long time and the occurrence of recurrent infections, and both of these causes are influenced by inadequate parenting from the womb until the first 1,000 days of birth [3].

Chronic malnutrition that occurs in stunting toddlers is caused by poor parenting practices, limited health services, lack of access to nutritious food, and lack of access to clean water [4]. Another opinion according to Khoirun Ni'mah and Siti Rahayu Nadhiroh (2015), in their research shows that low birth length, toddlers who do not get exclusive breastfeeding, low family income, low maternal education, and lack of mother's nutritional knowledge are factors related to the incidence of stunting in infants [5]. Another study according to Farah Okky Aridiyah (2015) also showed that the factors that influence stunting in children under five in rural and urban areas are mother's education, family income, mother's knowledge about nutrition, exclusive breastfeeding, age of MP-ASI, level of Adequacy of zinc and iron, a history of infectious diseases and genetic factors [6]. According to the Ministry of PPN / Bappenas, the causes of stunting are classified into 2 (two) namely direct and indirect causes. The cause is directly related to nutrition and health status, while the cause is not directly related to other factors outside health such as food security, social environment, health environment, and residential environment.

The magnitude of the impact of stunting made the government pay great attention to this problem. To handle this case, cross-sector involvement is needed. Including BKKBN. As a government institution that is concerned with population problems, BKKBN has specific and concrete activities in overcoming stunting, namely through the Population, Family Planning and Family Development (KKBP) program which has now changed its name to Proud Kencana which is short for "Pembangunan Keluarga, Kependudukan dan Keluarga Berencana". Bangga Kencana Program has many benefits for families. In terms of health, the Proud Kencana program is beneficial for mothers and children. For Mothers, the Bangga Kencana program can: a) Prevent anemia (lack of blood); b) KB can maintain health physical and reproductive health more optimal; c) Prevent excessive bleeding after childbirth and accelerate recovery of uterine conditions; d) Prevent Unwanted Pregnancy; e) Closer to the mother in health services; f) Increase the harmony of the family For children, the program Bangga Kencana can: a) Prevent malnutrition in children; b) Growth and development ak guaranteed; c) 6 months exclusive breastfeeding needs can be fulfilled. The efforts made in order to improve the achievements of the Bangga Kencana program are the establishment of a Kampung KB.

In general, the purpose of the establishment of the Kampung KB is to improve the quality of life of the community at the village level or equivalent through the Bangga Kencana program and the development of other related sectors in order to create quality small families. Whereas specifically, the Kampung KB was formed in addition to increasing the participation of the government, non-governmental and private institutions in facilitating, assisting and fostering the community to carry out the program and related sector development, also to increase public awareness about population-oriented development and community health development.

This is certainly in line with the problems being faced in Demak Regency. The high stunting rate in the Regency is expected to be suppressed by the intervention of the Kampung KB program which is modified according to the needs and characteristics of the people of Demak Regency.

Related to stunting, WHO (World Health Organization) has set a maximum limit of stunting sufferers, which is 20% of the total number of children under five. In Indonesia, the percentage of stunting toddlers in 2018 according to the results of the Basic Health Research (Riskesdas) was 30.8%, even reaching 37.2% in 2013. In the context of overcoming and accelerating the reduction of stunting in Indonesia, the government then set 1,000 priority villages stunting intervention in 100 districts / cities and 34 provinces [7,8]. The determination of 100 priority districts / cities is determined by looking at indicators of the number of stunting children under five, the prevalence of stunting, and the level of poverty until at least 1 district / city has been selected from all provinces, one of which is Demak Regency. The incidence of stunting in Demak Regency in 2013 was 50.28% (50,780 toddlers). Various efforts and programs have been carried out but have not yet reached maximum results, in 2019 the incidence of stunting in Demak Regency is still 50.23% (48,829 children under five years old) and 4.29% (6,129 children under five years old) potentially stunting [9].

The purpose of this study was to determine the effect of family planning optimization optimization interventions in improving community knowledge, attitudes, and practices as a Strategy for the Acceleration of Stunting Countermeasures in Demak Regency.

2 Method

2.1 Reserch design

This study uses a Randomize Control Trial (RCT) design designed to find out the effects of family planning optimization optimization interventions on villages with stunting toddlers in Demak Regency.

2.2 Population and sample

The population in this study included parents of toddlers who experienced stunting in Demak Regency.

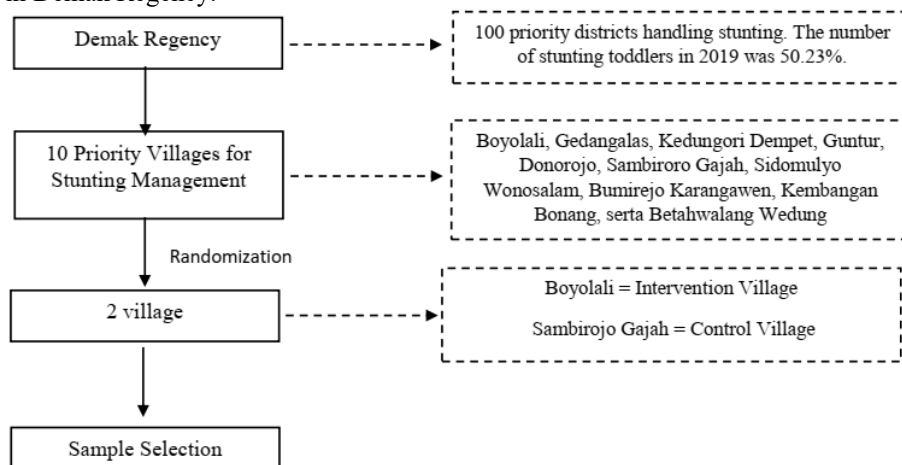

Fig. 1. Justification of Locus Selection, Population, and Research Samples

According to the inclusion criteria, 64 parents were selected to participate in the study. They were randomly divided into two groups: control and experimental groups (32 in each group). Inclusion criteria for patients are: parents who have stunting toddlers, are willing to participate, and live in Demak Regency. Exclusion criteria did not participate in one of the training sessions.

2.3 Data collection

Data were collected using 2 questionnaires. The first questionnaire was the Indonesian version of The Health Promoting Life Style Profile II (HPLP II) and a questionnaire prepared by researchers based on the PRECEDE-PROCEED model.

The HPLP II questionnaire was first developed by Walker et al in 1978. In the current study a multidimensional assessment was carried out by assessing health promotion behavior in six aspects namely nutrition (7 items), physical activity (7 items), responsibility for health (13 items), stress management (6 items), interpersonal relationships (8 items), and self-actualization (11 items). The questionnaire included 52 questions based on a four-item Likert scale with ratings: never = 1, sometimes = 2, often = 3, and always = 4. Total health promotion behavior scores between 52 and 208 with higher scores indicate a sedentary lifestyle healthier. For each aspect of behavior, scores are calculated separately. Therefore, the score for each subscale is calculated by the answer score given to questions from the same subscale. In each subscale and in the total scale, reaching less than 50% of the total score indicates bad status, 50% to 75% represents average status, and greater than 75% indicates good status.

The second questionnaire was prepared by the researcher based on the PRECEDE-PROCEED Model based on information found in the literature review. The questionnaire has four parts namely demographic information (including age, sex, subject and parent education, and occupation of the parents), predisposing factors (including 10 questions about knowledge and 15 questions about attitudes towards healthy lifestyle), supporting factors (including four questions to measure stress management skills, interpersonal relationships, self-actualization, access to and use of training resources), and reinforcement factors (consisting of three questions to measure support and encouragement of peers, family and health service staff). Questions related to knowledge, possible factors, and reinforcement factors are scored in the form of Yes = 1 and No = 0, while attitude questions are scored based on a 4-item Likert scale that ranges from strongly disagree = 1 to strongly agree = 4. Therefore, the total score ranges from the predisposing factors section to 25-70, the supporting factors section from 0-4, and the reinforcement factors section from 0-3 (higher scores indicate better health status).

3 Results and discussions

3.1 Stunting

Stunting is a chronic malnutrition problem that is caused by a lack of nutrition in a long time due to the provision of food that is not appropriate to nutritional needs. Stunting occurs when the fetus is still in the womb and only appears when the child is two years old. Nutritional deficiencies at an early age increase infant and child mortality, cause sufferers to get sick easily and have a posture that is not optimal as an adult [10].

Stunting in infants is a consequence of several factors that are often associated with poverty including nutrition, health, sanitation and the environment. The main factors causing stunting are: Humans need food for their survival [11]. Food is a source of energy to support all activities or human activities. A person cannot produce energy in excess of what is obtained from food unless he borrows or uses energy reserves in the body. But this habit of borrowing can lead to serious conditions, namely malnutrition, especially energy. The condition of poor environmental sanitation allows various types of diseases including diarrhea, helminthiasis, and digestive tract infections. If the child suffers from a digestive tract infection, absorption of nutrients will be disrupted which causes nutrient deficiencies. Someone who is deficient in nutrients will be susceptible to disease and experience growth disorders.

Stunting is a major nutritional problem that will have an impact on social and economic life in society. In addition, stunting can affect children under five in the long term, which is disturbing their health, education and productivity in the future. Stunting children under five tend to have difficulty achieving optimal growth and development potential both physically and psychomotor [12].

Developmental disorder is a condition of the child not being able to achieve the task of development at the estimated time. Disorders can occur in many areas of development, for example in motor, language, social, or thinking. Stunting that occurs during childhood is a risk factor for increased mortality, cognitive abilities, and low motor development and unbalanced bodily functions [13].

3.2 Kampung KB

Hearing the term "Kampung", the impression that arises in our minds will definitely be aimed at a place of residence of a group of people or families with all the backwardness, limitations, lagging, old-fashioned, slum, remote, and several other designations associated with the village.

We cannot deny that the village is very identical with such terms, so is the case with the KB Village which has recently become a popular icon not only among the BKKBN, but has also been widely discussed by departmental institutions or non-departmental level from the regional level to the central level.

Indeed, since the KB Village was announced by the President of Indonesia (Ir. Joko Widodo) in January 2016, that the KB Village has been widely discussed by the public from the lower classes, the middle to the elite, and even writings on the KB village many fill in the news columns in the mass media (newspapers, magazines, tabloids) and even become quite hot and popular news in the electronic media.

So why is this KB village established, there are a number of things behind it, namely: (1) the KB program no longer resonates and sounds echoed like in the New Order era, (2) to improve the quality of life of people at the village level or equivalent through the Proud program Kencana and related sector development in order to realize quality small families, (3) strengthening the Proud Kencana program which is

managed and organized from, by and for the community, (4) realizing Indonesia's development ideals as contained in Nawacita especially the 3rd priority agenda, namely "Starting development from the periphery by strengthening regions and villages within the framework of a unitary state "and the 5th Priority Agenda, namely" Improving the quality of life of the Indonesian people", (5) promoting and reviving family planning programs to welcome the achievement of demographic bonuses that are predicted to occur in in 2010 - 2030.

3.3 Kampung KB as a forum for community empowerment

Although the establishment of the Kampung KB is mandated by the BKKBN, in principle the Kampung KB is a manifestation of the synergy between several relevant ministries from the central government and regional governments, work partners, and stakeholders, and does not miss the direct participation of the local community. Therefore, this Kampung KB is expected to be a miniature or portrait (portrait) of a village in which there is integration of the Population, Family Planning and Family Development programs which are synergized with related sector development programs which are carried out systematically and systematically, including in the health sector development. .

The Kampung KB was actually designed as an effort to ground, reappoint, and revitalize the Proud Kencana program to bring access to services to families and communities in an effort to actualize and apply 8 (eight) whole family functions in the community. Thus the activities carried out in the Kampung KB are not only identical to the use and installation of contraception, but are an integrated development program and integrated with various other development programs. So that we can make this Kampung KB forum a vehicle for community empowerment through various programs that lead to efforts to change people's attitudes, behaviors and ways of thinking towards a better way.

The aim of the intervention is to obtain positive changes from behavior modification in the six aspects of HPLP in the experimental group. Initially, a four-phase PRECEDE assessment is carried out and then appropriate interventions based on the assessment are developed, implemented and evaluated.

Interventions that are developed refer to the theoretical framework of behavior change communication. To accelerate the handling of health problems, strategic interventions need to be developed that include policies, organizations, communities, interpersonal, and individuals.

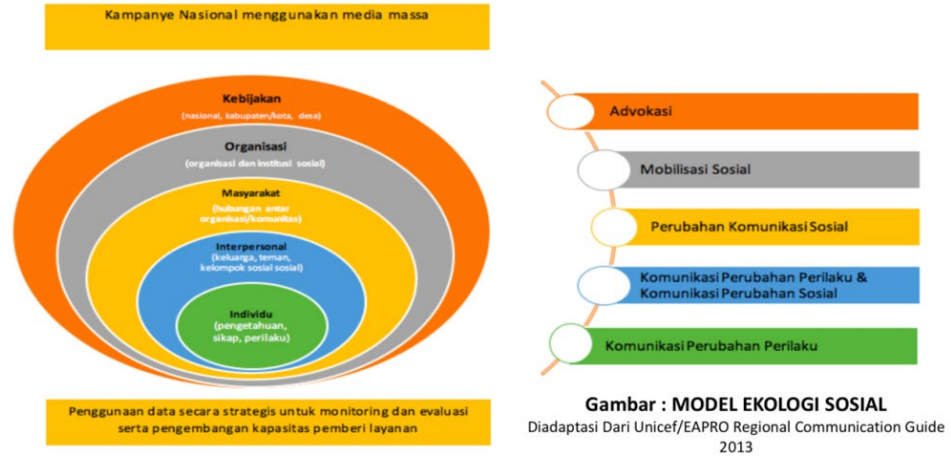

Fig. 2. Intervention Model Framework

Kampung KB is a village-level regional unit with certain criteria in which there is an integration of the Proud Provisional program and related sector development carried out systematically and systematically. It is hoped that the formation of the Kampung KB program by BKKBN is expected to carry out the Proud of the Kencana program and other development programs in an integrated and concurrent manner. The purpose of the formation of the Kampung KB is to improve the quality of life of families and communities through the Proudly Proposed program integrated with other development sectors. The Kampung KB Program will then be optimized in the form of activity in accordance with the framework of the intervention model, namely advocacy, social mobilization, social communication change, and behavior change communication. In detail are:

a. Advocation

. Socialization of Demak Regent Regulation Number 29 Year 2019

In an effort to optimize the KB village program to cope with the stunting incident in Demak, the initial step taken is advocacy to policy makers in the Kampung KB area such as the Village Head, RW Chairperson, and RT Chairperson. This advocacy began with the socialization of Demak Regent Regulation No. 29 of 2019 concerning the Stunting Management Regional Action Plan in Demak Regency in 2019-2021. This regulation concerning the Regional Government action plan that contains programs and activities in the field of stunting countermeasures in order to realize quality and competitive human resources, so that with socialization to policy makers it is expected that they will be able to know and understand the contents of these regulations and commit to participate in efforts to prevent stunting by optimizing the Kampung KB program [14].

Proposed Village Regulations Regarding Stunting

The results of the advocacy activities that have been carried out to policy makers are expected to produce related Village Regulations on optimizing family planning villages in overcoming stunting in the region.

b. Social Mobilitation.

In the opinion of Soerjono Soekanto, the understanding of social mobility is a movement in social structure, that is, certain patterns that govern the organization of a social group. In this activity required the formation of organizing in the form of cadres with the program: 1) Formation of cadres concerned with stunting. The formation of these cadres is to coordinate if there are stunting to be referred and handled. 2) Data collection and examination of pregnant women. The importance in overcoming stunting starts from pregnant women, in this activity the cadres list all pregnant women to carry out pregnancy-related examinations. 3) Early detection of stunting cases: In this activity the cadres detect all toddlers in prevention efforts and if there is detected stunting, the cadres immediately make a referral.

c. Change in social communication

. Wilbur Schramm through his study commissioned by UNESCO examines the role of communication in national development. In his report entitled *Mass Media and National Development: The Role of Information in Developing Countries*, in 1964, Schramm stated the role of mass media in national development as an agent of social change. The location of its role is to help accelerate the process of transition from traditional societies to modern societies. In particular the transition from habits that hinder development to new attitudes that are responsive to reform for development [15]. Development is expected to be carried out voluntarily in which every individual takes part in it and information about development is received equally. With this in mind, family planning changes can be implemented in social communication to provide education in increasing the level of knowledge targeting pregnant and lactating women and mothers with children under five. This activity takes place at the *posyandu* by providing: 1) Stunting Education. This activity provides knowledge of the causes and effects of stunting. 2) Education of 1000 HPK. This educational activity provides knowledge of how important 1000 HPKs are related to family education, especially mothers during pregnancy, childbirth and breastfeeding, nursing care for infants and toddlers.

d. Communication change behavior

. In the Kampung KB there is a Toddler Family Development Program (BKB), this activity provides cadres counseling stimulation of child development and counseling for families who have toddlers. This program can also be used to provide education regarding 1000 HPK to fertile age couples.

Behavior change communication can also be provided to adolescents through the Youth Information and Counseling Center (PIK-R) program. PIK-R is a forum for PKBR program activities managed from, by, and for adolescents to provide information and counseling services on Family Life Planning for Adolescents and other supporting activities including education related to stunting [16].



Fig. 3. Optimization of the KB Village as a Strategy for the Acceleration of Stunting in the District of Demak

Process Evaluation

Process evaluation occurs during program implementation and is used to evaluate the process in which the program is run. In this phase, the achievement of intervention goals is measured. In this study, process evaluation includes evaluating program components such as program staff, methods, materials used, and activities.

Impact Evaluation

This phase determines the direct effect of the program on target behavior, and it occurs after the program ends. In this study, impact evaluation consists of assessing changes in predisposing, reinforcing, and enabling factors that influence behavior immediately after and one month after intervention activities through questionnaire analysis.

4 Conclusions

The results of the research is that the BKKBN has developed the Kampung KB program. The spirit of forming and establishing Kampung KB throughout the archipelago has resulted in hundreds of Kampung KB. The presence of Kampung KB aimed to improve the quality of life of the community at the village level or equivalent through the Bangsa Kencana program and the development of other sectors to create quality small families including on the family health side. It is hoped that the influence of the optimization of the Kampung KB as a strategy for the acceleration of stunting countermeasures. The intervention is still ongoing, so for the results of the effectiveness of the intervention cannot be reported.

References

- [1] Budhathoki SS, Bhandari A, Gurung R, Gurung A, Kc A. Stunting Among Under 5-Year-Olds in Nepal: Trends and Risk Factors. *Matern Child Health J.* 2019;1-9.
- [2] Tanjung C, Prawitasari T, Sjarif DR. Comments on “ Stunting is not a synonym of malnutrition. ” *Eur J Clin Nutr.* 2020;3-4.
- [3] Habimana S, Biracyaza E. Risk Factors Of Stunting Among Children Under 5 Years Of Age In The Eastern And Western Provinces Of Rwanda: Analysis Of Rwanda Demographic And Health Survey 2014/2015. *Pediatr Heal Med Ther.* 2019; 10:115-130.
- [4] Titaley CR, Ariawan I, Hapsari D, Muasyaroh A, Dibley MJ. Determinants of the stunting of children under two years old in Indonesia: A multilevel analysis of the 2013 Indonesia basic health survey. *Nutrients.* 2019;11(5).
- [5] Nadhiroh, Siti Rahayu; Ni'mah K. Faktor yang berhubungan dengan kejadian. *Media Gizi Indones.* 2010;1:13-19.
- [6] Aridiyah FO, Rohmawati N, Ririanty M. Faktor-faktor yang Mempengaruhi Kejadian Stunting pada Anak Balita di Wilayah Pedesaan dan Perkotaan. *J Pustaka Kesehat.* 2015;3(1):163-170.
- [7] Dinas Kesehatan Propinsi Jawa Tengah. *Profil Kesehatan Jawa Tengah.*
- [8] Kementerian PPN. *Rencana Aksi Nasional dalam Rangka Penurunan Stunting: Rembuk Stunting.* Jakarta: Kementerian Kesehatan Republik Indonesia; 2018.
- [9] Profil Kesehatan Kab. Demak, <https://drive.google.com/file/d/14gzaQGrHHypirkUCIhWDb5A7V03yOuX/view>, last accessed: 17 June 2020.
- [10] Aguayo VM, Nair R, Badgaiyan N, Krishna V. Determinants of stunting and poor linear growth in children under 2 years of age in India: An in-depth analysis of Maharashtra's comprehensive nutrition survey. *Matern Child Nutr.* 2016;12:121-140.
- [11] Woldeamanuel BT, Tesfaye TT. Risk Factors Associated with Under-Five Stunting, Wasting, and Underweight Based on Ethiopian Demographic Health Survey Datasets in Tigray Region, Ethiopia. *J Nutr Metab.* 2019;2019.
- [12] Alderman H, Nguyen PH, Menon P. Progress in reducing child mortality and stunting in India: An application of the Lives Saved Tool. *Health Policy Plan.* 2019;34(9):667-675.
- [13] Rezapour B, Mostafavi F, Khalkhali HR. School-Based and PRECEDE-PROCEED-Model Intervention to Promote Physical Activity in the High School Students: Case Study of Iran. *Glob J Health Sci.* 2016;8(9):271.
- [14] Astuti S, Megawati G, Samson C. Gerakan Pencegahan Stunting Melalui Pemberdayaan Masyarakat Di Kecamatan Jatinangor Kabupaten Sumedang. *Dharmakarya.* 2018;7(3):185-188.
- [15] Calano BJD, Cacal MJB, Cal CB, et al. Effectiveness of a community-based health programme on the blood pressure control, adherence and knowledge of adults with hypertension: A PRECEDE-PROCEED model approach. *J Clin Nurs.* 2019;28(9-10):1879-1888.
- [16] Bazpour M, Gheibizadeh M, Malehi AS, Keikhaei B. The effect of a training program based on the PRECEDE-PROCEED model on lifestyle of adolescents with Beta-Thalassemia: A randomized controlled clinical trial. *Int J Hematol Stem Cell Res.* 2019;13(1):12-19.

Measurement of Exposure to Black Carbon and Heavy Metals on Cycle Paths in Semarang City

Bambang Priyono¹, Agung Wahyudi², Mustafa Daru Affandi³, Efa Nugroho⁴
{bambangpriyono@mail.unnes.ac.id¹, agungwahyudi@mail.unnes.ac.id², da-
ru.affandi@mail.unnes.ac.id³}

Universitas Negeri Semarang, Semarang, Indonesia^{1,2,3,4}

Abstract. Cycling is very popular regardless of age from young to old and even children. The number of cyclists increased during the COVID-19 pandemic. There is no Open Sport Space or a special lane that causes the participants to choose the highway as the route. Besides being at risk of accidents, they are also vulnerable to traffic air pollutants or the traffic-related air pollutants (TRAP). The TRAP components are Carbon Black (BC), Nitrogen Dioxide (NO₂), Ultrafine Particles (UFPs), and Heavy Metals. TRAP is dangerous for health. The purpose of this study was to determine the level of pollutants on the highway that was passed by cyclists. This research was experimental research. The population and research sample was Semarang City Highway and cyclist community. The results of this study showed that the levels of pollutants during the COVID-19 pandemic were lower when compared to normal days.

Keywords: Exposure, Pollutant, Cyclist.

1 Introduction

The phenomenon of sports culture in the community is believed to be not merely a health-supporting activity, but also a support for social needs in which health, psychological, and socio-cultural fitness values can be attached. Sport can make a real valuable contribution and inspire human well-being and survival from physical, spiritual and social aspects. The meaning contained in sports activities is not just physical education and achievement, but more broadly related to overall goals, and can contribute to life for each individual in physical, mental and social aspects. The sport that is currently favored by the public right now is cycling.

Cycling is now a trend among the people, in addition to running. Some even think that besides being used as a transportation and sports suggestion, cycling is also a lifestyle. Cycling is very popular regardless of age from young to old and even children. We have now met many workers who are cycling to go to the office and also elementary school students to students who are cycling to their respective destinations.

To be able to carry out sports activities optimally, sports facilities and infrastructure are needed, including open spaces that can be accessed to exercise so that they can move freely

without any obstacles. Open space in sports (OSS) is a basic requirement for sports activities. Without adequate and narrow open spaces it is difficult to expect community participation in sports activities. The more public sports facilities and infrastructure available, the easier it is for people to use and use them for sports activities. Conversely, the more limited public sports facilities and infrastructure available, the more limited the opportunity for people to use and utilize them for sports activities. Thus, the availability of public sports facilities and infrastructure will affect the level and pattern of community participation in sports.

Cycling is a recreational or sports activity, and is one of the modes of land transportation that uses bicycles. The bike was first introduced in the 19th century AD. Many cycling enthusiasts who carry out these activities in various fields, such as hills, steep terrain or just rural and urban areas. People who use bicycles as a routine mode of transportation can also be called commuters. The use of bicycles as a mode of routine transportation is not only done by workers who work in the informal sector, but also is done by workers who work in the formal sector.

The number of cyclists is now increasingly found on the streets. In other words, this relaxed but healthy exercise is increasingly in demand. The cyclist community is also increasing now.

But cyclists rarely pay attention to the health risks that can arise if they carry out their hobbies in places where air pollution is high. Unwittingly the dirty air we breathe every day, can be very dangerous for health. Yet according to WHO, currently 9 out of 10 people breathe in polluted air. The impact of air pollution has also killed around 7 million people each year.

Increased interest in cycling in the city of Semarang is not matched by an increase in supporting facilities and infrastructure. The absence of Open Space Sports (OSS) or special lanes causes the participants to choose the highway as the route. Besides being at risk of accidents, they are also vulnerable to exposure to air pollutants due to traffic or the term traffic-related air pollutants (TRAP). The TRAP components include Carbon Black (BC), Nitrogen Dioxide (NO₂), Ultrafin Particles (UFPs), and Heavy Metals. TRAP is dangerous for health. TRAP has been linked to several adverse health outcomes including increased asthma, cardiovascular risk, risk of lung cancer, fatal myocardial infarction, and increased mortality. TRAP is a silent killer because of its physical nature which is tasteless, colorless, and odorless, but in high concentrations can cause death in humans who are exposed quickly.

A study on TRAP exposure for cyclists in Semarang City is needed so that efforts to mitigate exposure to air pollution for cyclists can be carried out. The purpose of this study is to determine the Exposure of Black Carbon, Ultrafin Particles, and Heavy Metals in the Cycling Community.

2 Method

This research is an experimental research with one group pretest post test design. The population and sample of the study are Semarang City Cyclists Community.

The study was carried out by measuring pollutants on the routes that cyclists traveled and exposure to pollutants on cyclists. Because of the high temporal variability of TRAP that is measured, monitoring can only be considered representative if the data series is large.

In our study, walking monitoring per week (according to the cycling schedule) was carried out along the route of travel. For each route 8 repetitions are performed, between 6/1/2020 and 3/23/2020. To consider the effects of road congestion and looseness, the route changes every week. The average cycling speed is 20 km / hour. Also installed a heart rate measuring device.

3 Results and discussions

The level of atmospheric pollution in a heterogeneous and typical urban environment can be known to vary greatly in space and time. While spatial variation is the main association with differences in traffic intensity, urban topology and distance to individual pollutant sources, temporal variations consist of day to day (mainly meteorological fluctuations and urban backgrounds), daily conditions (mainly due to traffic dynamics) and scale variations micro (short-term single event) [1].

Because the traditional stationary air quality monitoring network is limited in terms of spatial coverage, cellular monitoring devices, the possibility of personalized monitoring and high resolution, has become increasingly popular over the past decade [2-4]. Especially for atmospheric pollutants that experience large temporal spatial variations in urban environments. Cellular monitoring provides valuable insights into the range of atmospheric pollution faced by city dwellers in daily life, and the potential for this to occur in the local area which, as a result, can be targeted by policy makers and urban planning planners [5,6].

Table 1. Recap of CO level measurement

No	Location	Data read (ppm)					Average
		1	2	3	4	5	
1	Simpang Lima	16	15	18	16	16	16,2
2	Pertigaan Thamrin	14	14	13	15	14	14
3	Tugumuda	14	13	12	16	17	14,4
4	Perempatan Petompon	12	11	12	12	10	11,4

As with walking, cyclist exposure is also quite a contentious issue, with research providing conflicting results. Studies found CO levels to be substantially lower than cars, and lower than pedestrians during most sampling instances Later research confirmed the contrary, with cyclists receiving higher levels than walk, car and bus.

Nevertheless, there are various potential factors influencing cyclist exposure. These include: position on the road; traffic light timings; ability to pass between congested traffic; height of cyclist from ground; chosen route; traffic density and use of bus or cyclist lanes. In a journal entitled "Personal exposure to Black Carbon in transport microenvironments", the results showed 6% of the time spent in transportation but contributed to carbon black exposure to the body by 21% [7]. The concentration of carbon black in transportation is 2-5 times higher than its concentration in the home. The highest exposure to black carbon uses bus, motorcycle and car transportation while the lowest uses train. Exposure by cycling or walking in busy traffic also results in high exposure, whereas using bicycles in a quiet or rural area receives low carbon black exposure. For the use of a car at work activities receive higher carbon black exposure than using a car for recreational activities. The highest dose of

carbon black inhalation occurs when cycling or walking casually on a highway or urban road.

Table 2. Recap of PM 10 dust measurement

No	Location	Time (Min)	Air Flow (l/m)	Air Volume (m3)	Weight 2	Weight 1	Dust Weight	Dust (MG/m3)	Conc
1	Simpang lima	60	750	45	5122	4720	402	8,933333333	
2	pertigaan thamrin	60	700	42	5104	4940	164	3,904761905	
3	tugumuda	60	750	45	5098	4855	243	5,4	
4	perempatan petompon	60	750	45	4990	4856	134	2,977777778	

Jelle Hofman et al (2018), with the title "Cyclist exposure to black carbon, ultrafine particles and heavy metals: An experimental study along two commuting routes near Antwerp, Belgium". The results showed that the average black carbon was 300% and ultrafine particles were 20% higher in the traffic lane than in the bicycle lane (vehicle free) [8]. This research shows that cyclists who wish to reduce their exposure to black carbon, ultrafine particles and heavy metals must choose lane routes with fewer vehicles or busy lanes.

The exposure of carbon black on the main (busy) line was very high especially at the crossroads, where many machines stopped. This exposure is greatly reduced when cyclists pass alternative route routes that do not have many vehicles and do not have many intersections. Measurements in the urban environment, influenced by traffic and biomass burning, show that air pollution of the main traffic, and carbon black in particular, has a significant impact on cyclist exposure. The results imply that cycling route planning must aim for greater distances between cycling routes and motorized traffic, must consider the number of intersections and consider at the same time the exchange / distance.

Table 3. Recap of the results of lung phalms measurement

No	Name	Gender	Age	FVC	FEV1	FEV1/FVC %	PEF	Information
1	Asti	F	29	86	88	104	73	Normal Spirometry
2	Budi	M	36	93	87	98	62	Normal Spirometry
3	Choirul	M	30	94	96	104	71	Normal Spirometry
4	Ramlan	M	69	100	115	119	81	Normal Spirometry
5	Sigalingging	M	37	134	106	83	76	Normal Spirometry
6	Suryadi	M	58	86	97	93	84	Normal Spirometry
7	Tatang	M	65	92	112	125	135	Normal Spirometry

The effect of environmental control on CO levels and dust on shows that age has no influence on road exposure which can cause lung disorders. Statistical results showed that there was no significant difference between sex and lung function ($p > 0.05$). Statistical results between years of service and pulmonary function did not show a significant difference ($p > 0.05$). Based on exercise habits, exercise generally can increase lung capacity. Individuals who do regular exercise lung capacity will increase. The conclusion is that there is no significant difference between age, and sex, on lung capacity. However, there is a relationship between exercise habits and lung function.

4 Conclusions

The results of this study showed that the levels of pollutants during the COVID-19 pandemic were lower when compared to normal days. But that does not mean harmless to cyclists. There is no significant difference between age, and sex, on lung capacity. However, there is a relationship between exercise habits and lung function.

For the next stop of research is measuring exposure to pollutants in cyclists on the highway.

References

- [1] Pattinson WJ. Cyclist Exposure To Traffic Pollution: Microscale Variance, The Impact Of Route Choice And Comparisons To Other Modal Choices In Two New Zealand Cities. Christchurch: University of Caterbury; 2009.
- [2] Gulliver J, Briggs D. Journey-time exposure to particulate air pollution. *Atmos. Environ.* 2007; 41:7195-7207.
- [3] Berghmans P, Bleux N, Panis LI, Mishra VK, Torfs R, Van Poppel M. Exposure assessment of a cyclist to PM10 and ultrafine particles. *Sci. Total Environ.* 2009; 407(4): 1286-1298.
- [4] Adams HS, Nieuwenhuijse, MJ, Colvile RN, Older MJ, Kendall M. Assessment of road users elemental carbon personal exposure levels, London, UK., *Atmos. Environ.* 2002; 36(34):5335-5342.
- [5] Boogaard H, Borgman F, Kamminga J, Hoek G. Exposure to ultrafine and fine particles and noise during cycling and driving in 11 Dutch cities. *Atmos. Environ.* 2009; 43(27):4234-4242.
- [6] Brunekreef B, Holgate ST. Air pollution and health. *The Lancet.* 2002; 360(9341): 1233-1242.
- [7] Dons E, Panis LI, Poppel M, Theunis J, Wets G. Personal exposure to Black Carbon in transport microenvironments. *Atmos. Environ.* 2012; 55:392-398.
- [8] Jelle H, Roeland S, Steven J, Ronny B, Silvia L. Cyclist exposure to black carbon, ultrafine particles and heavy metals: An experimental study along two commuting routes near Antwerp, Belgium Environmental Research. *Environ. Res.* 2018; 164:530-538.

Modeling Associated with Picky Eating Behavior on Stunted Children

Bertakalswa Hermawati¹, Oktia Woro Kasmini Handayani², Dhevy Fajriyatul Umma³, Adinda Yustika Seftiani⁴
 {bertahermawati@gmail.com¹, oktia_woro@yahoo.co.id², dhevyfajriyatul14@gmail.com³}

Universitas Negeri Semarang, Semarang, Indonesia^{1,2,3,4}

Abstract. Long term consequence of picky eater is under optimal growth and development difficulties. The objectives of this study were to determine the modeling associated with picky eating behavior on stunted children. A questionnaire was used to conduct a cross-sectional study of 36 mothers with stunted children under five years old who were picky eater behavior. Data collected included: socio-demographic, modeling, and picky eater behavior. The study design was case-control, Data analysis using chi-square. The result showed that the modeling associated with picky eating significantly ($p= 0.040$), $p < 0.050$. The findings suggest that all family members may intentionally and unintentionally model healthy and unhealthy foods.

Keywords: modeling, picky eater, stunted children

1 Introduction

Stunting is a major nutrition issue facing Indonesia today. World Health Organization (WHO) states Indonesia is the third country with the highest prevalence of stunting in the Southeast Asia / South-East Asia Regional (SEAR) region. There were 36.4% of stunted children in Indonesia in 2005-2017 [1]. Stunting is the impaired growth and development of children. A child is defined as stunting if their height for age is more than two standard deviations below the median of the World Health Organization (WHO) Child Growth Standards [2]. It is caused by several conditions such as poor nutrition, recurrent infections, and inadequate psychosocial stimulation.

One of the factors that contribute to stunted growth and development is an inadequate infant and young child feeding [2] because of a picky eater. Although picky eaters are a common behavior that occurs during childhood, picky eaters have become a serious problem in nutrient intake in some children. Several studies showed that there is a correlation between picky eaters and stunted children. 77% of stunted children under five are picky eater [3]. According to recent studies, a decrease in appetite and intake due to the behavior resulting in children under five becoming lack of energy and nutrients that inhibit growth [3][4]. Besides, a lower intake of vitamin E, vitamin C, folate, and fiber in children with a picky eater can cause immune responses and a weak digestive system [5].

Picky eating is a common behavior, also known as fussy eating, selective eating, faddy eating, and choosy eating [5–7]. Others said that picky eater is defined as an unwillingness to eat familiar foods or try new foods [4,7] which are characterized by various reactions to refuse to eat certain types of foods, (texture, color, or mouthfeel), only wants to eat the same foods over and over and food are cooked with a certain method or booth. The child's response also varies in eating behavior, such as feeling full quickly, eat slow, talkative, fussy about food, less responsive, and do not enjoy eating [8]. Studies on this subject revealed that children tend to dislike vegetables and prefer not to eat fruits, potatoes, and meat [5]. The prevalence of picky eating from 6 to 50% [9]. In Indonesia, the prevalence of stunting about 58% [4]. Studies in China showed that the prevalence of picky eating as high as 54% among children under five and in Singapore 49.2% and Vietnam 25.3% [10].

Picky eating can cause distress in parents, and in their attempts to increase healthy food intake by some strategies. Regardless of the strategy to handle fussy eaters, parents as role models are a factor that influences healthy eating habits in children. Albert Bandura on his Social Learning Theory said that a process of observational learning relies on the parent to encourage and facilitate behavior within the child, with the consequence of the behavior becoming habitual is modeling [11]. Parental food behavior was considered to have both positive and negative influences on individual eating habits [12]. Introducing children to new foods within a positive atmosphere may encourage taste acquisition and promote more varied and healthy food preferences [13]. Similarly, Savage [14] said parents have the power to shape children's early experiences with food and eating. Parental influence to select the foods of the family diet, serve as models of eating that children learn to emulate, and use feeding practices to stimulate the development of culturally appropriate eating patterns and behaviors in their children.

The study aimed to determine the modeling associated with picky eating behavior on stunted children in Demak region. By understanding the relationship between these factors, we can examine the effective improvement strategies of children feeding practices.

2 Methods

The population was mothers with stunted children in Demak region. The sampling method used was purposive sampling. The sample in this study was 36 mothers with stunted children under five and lived in three villages: Kembangan, Tridonorejo, and Tlogoboyo.

The inclusion criteria in this study were mothers with stunted children who lived in the study area and were willing to be involved in this study. Mothers are not included in this study were mothers with stunted children, lived in the study area but were willing to be involved in this study

This study uses a cross-sectional design. This study uses a questionnaire instrument to determine the modeling and picky eater. Data were obtained by interviewing mothers using the instrument's guide. All participants were interviewed to obtain data

on socio-demography, modeling, and picky eater. The variables of socio-demography have created the category of stunting, sex, and socio-economic status. The questionnaire for modeling addressed two general areas (people who are role models and food preferences). All the data collected from the study was obtained through face-to-face interviews with mothers. This interview takes about 20 minutes. The picky eater set was developed by using several variables analysis (frequencies, types of food like, and dislike). The frequency variable on picky eater was ranked in ascending order and then categorized into quantile (1) never, (2) seldom, (3) sometimes (4) often. Data analysis in this study uses quantitative methods and uses a chi-square test to determine the relationship between two nominal variables.

3 Results and discussion

36 parent participants completed the instrument. The subject characteristics are presented in the following table 1.

Table 1. Demographic Characteristics of Respondent

Variable		n: 36	%
Stunting	Severe Stunted	9	25%
	Stunted	27	75%
Sex	Boy	19	53%
	Girls	17	47%
Socio-economic status	Middle high	1	1%
	Low	35	99%

Note: Income level based on Regional Minimum Wages at Demak, Central Java Province, Indonesia. Middle Low: Less than IDR 2.420.000. Middle High: More than IDR 2.420.000

Based on this data, 25% severely stunted children who were picky eater behavior, and 75% stunted children who were picky eater behavior, and 53% of boys are stunted who were picky eater behavior and 47% of girls are stunted who were picky eater behavior. Most respondents are low socio-economic status (99%), and 1% is middle high.

Table 2. Characteristics of Picky Eater

Variable		Respondent	%
Child's response to food (n : 32)	Tantrum (angry, crying)	14	44
	Refuse to open mouth	7	22
	Feeding Distraction	6	19
	Food refusal through a verbal reaction	3	9
	Self-induced vomiting	1	3
	Pushes foods around the plate	1	3
Reasons the child refuses to eat (n: 32)	Dislike food	26 (fishy: 2)	81
	Reluctant to eat rice	3	9
	Dislike taste	2	6
	It hard to floss the tiny pieces of food that gets stuck in between his teeth	1	4
Food likes	Egg	13	41

(n: 32)	Fish	8	25
	Soy (soy sauce, tofu, and tempeh)	3	9
	Candy	3	9
	Chicken	2	7
	Sausage	1	3
	Biscuit	1	3
	Snack	1	3
Food dislikes (n :32)	Rice	7	22
	Fish	5	16
	Soy (Tofu and tempeh)	9	28
	Fruit	3	9
	Chicken	3	9
	Egg	1	3
	Spicy foods	2	7
	Coconut milk	1	3
Vegetable	1	3	
Role model for the children (n : 17)	Mother	9	53
	Father	6	35
	Siblings	1	6
	All family member	1	6
Food /Drink choice. Imitation of role models' to eat food (n:17)	Coffee	5	31
	Ice	3	19
	Chicken	1	6
	Fried food	1	6
	Snack	1	6
	Kebab	1	6
	Egg	1	6
	Fruit	1	6
	Instant noodles	1	6
	Sunflower seed	1	6
	Fish	1	6
Food/Drink choice. Imitation of role models' not to eat food (n:17)	Fruit	9	53
	Vegetables	5	29
	Fish	2	12
	Ice	1	6

This study revealed that the child refuses the food with many reactions: 44% tantrum (angry, crying), 22% refuse to open mouth, 19% feeding distraction, and 15% others (food refusal through verbal reaction, self-induced vomiting, pushes foods around the plate). Besides, the reasons the child refuses to eat are 81% dislike food, 9% reluctant to eat rice, 6% dislike taste, and 4% it hard to floss the tiny pieces of food that get stuck in between his teeth. The study also found that the children like the food such as 41% egg, 25% fish, 3% candy/chocolate, and 3% soy (soy sauce, tofu, and tempeh) and dislike the food such as 28% soy, 22% rice and 16% fish. Role models to imitate the eating behavior are 53% mother, 35% father, 6% siblings, and 6% all family members. Besides, the food choice that the children imitate' to eat and drink is ice and coffee, the food choice that the children imitate not to eat is 53% fruit, 29% vegetables, and 12% fish.

Table 3. Statistic Result Test between modeling and picky eater

Variable	Total numbers of Picky Eater's cases		P
	Yes	No	
Role model (n=36)			0.040
Yes (n =17)	13(76%)	4 (24%)	
No (n=19)	19 (100%)	0 (0%)	

With a total of 36 respondents, it was found that there was an association between modeling and picky eater in children under five significantly with a value of $p < 0.05$.

Picky eating is defined as "sometimes" or "often" does not eat well and refuses to eat [6]. It is characterized by an unwillingness to eat familiar foods or to try new foods, as well as strong food preferences [15]. This study revealed 89% of stunted children under five years old were picky eater. There are many studies on the prevalence of picky eating in childhood, and a large variation in prevalence was found [16]. The prevalence of picky eating in Asia children above 50% [10,17]. This study showed that the children display refuse to eat such as self-induced vomiting, feeding distraction, food refusal through verbal reaction, tantrum, refuse to open mouth, pushes foods around the plate.

Based on this study, there are few reasons why the children are refusing to eat a certain food: dislike the food, dislike the taste, and reluctant to eat rice. This study revealed the most favorite food such as egg, fish, soy (tofu, tempeh, soy sauce), and candy. On another side, this study found that different types of food refusal by some children such as rice, fish, and soy (tofu and tempeh). Picky eater often has inadequacy of some nutrients, reduced energy intake, eat fewer fruits and vegetables, and have lower intakes of dietary fiber [7,18].

As a result, many healthy nutrients are not absorbed properly in children that related long-term consequences include a weakened immune system then causes the emergence of diseases in children. It can be effective for stunting. The picky eater was found in this study of stunted children. Similarly, the other study revealed picky eating was relatively prevalent among stunted Vietnamese children under five years of age [10]. This study also showed that there are two classifications of prevalence in stunting namely severe stunted and stunted. The proportions of stunted boys been higher than girls in this study. Similarly, some studies report on sex differences in stunting and find higher odds for boys than for girls [19,20]. Elsmen and Killbride said that stunting prevalence of different sex is caused by health conditions, low birth weight, and in utero health conditions. This study also found epidemiological evidence that young girls are less vulnerable to adverse health outcomes than young boys. increase the odds of stunting more for boys than for girls. Preterm-born males and those with low birth weight are worse off than their female counterparts. It means in utero health conditions are important for child health after birth [19].

The children develop picky eating habits by modeling their parents' fussy eating habits. This study found that modeling is associated with a picky eater in stunted children. They learn about eating behavior from their parents, siblings, and all family. This research also showed that a mother is the most role model for the children. Indeed, mothers have an emotional attachment to their children's eating behavior. They have awareness about food and eating changes [21]. Besides, Albert Bandura in his theory, Social Learning state that most people's behavior is learned, either deliberately or inadvertently through the influence of example. This evidence suggests a good example is therefore a much better teacher than the consequences of unguided actions [22]. In line with the ecological model of developing food choices by Urie Bronfenbrenner on This Ecological Systems Theory, the interaction of different environmental factors may result in human behavior. Parents provide food environments and experiences with food and eating for their children. Children model themselves on their parents' eating behaviors, eating-related attitudes, type of food, lifestyle, and satisfaction or dissatisfaction regarding body image [21].

4 Conclusions

This study found associations between modeling and picky eater. Family feeding behavior has a significant effect on a child's food preference. To encourage their child's food preferences, all members shall utilize many diverse behaviors to get effective strategies for healthy food intake during mealtimes.

Acknowledgments

This study was funded by the Budget Implementation List (Daftar Isian Pelaksanaan Anggaran/DIPA), Sports Science Faculty, Universitas Negeri Semarang (UNNES). We would like to thank the head of Public Health Center Bonang 1, Central Java, Indonesia, all participants in this research. This article was approved by the Health Research Ethics Committee (HREC), Universitas Negeri Semarang.

References

- [1] Pusat Data dan Informasi KKR. Situasi Balita Pendek (Stunting) di Indonesia. 2018.
- [2] WHO. WHA Global Nutrition Targets 2025: Stunting Policy Brief. 2018.
- [3] Nurmalasari Y, Utami D, Perkasa B. Picky eating and stunting in children aged 2 to 5 years in central Lampung , Indonesia. *Malahayati Int J Nurs Heal Sci.* 2020;03:29–34.
- [4] Putri AN, Muniroh L. Hubungan Perilaku Picky eater dengan Tingkat Kecukupan Zat Gizi dan Status Gizi Anak Usia Prasekolah Di Gayungsari Correlation of Picky Eater with Intake Adequacy and Nutritional Status in Preschool-Aged Children in Gayungsari. *Amerta Nutr.* 2019;232–8.
- [5] Wolstenholme H, Kelly C, Hennessy M, Heary C. Childhood fussy/picky eating behaviors : a systematic review and synthesis of qualitative studies. *Int J Behav Nutr Phys Act. International Journal of Behavioral Nutrition and Physical Activity;* 2020;1–22.
- [6] Samuel TM, Musa-Veloso K, Ho M, Venditti C, Shakhhalili-Dulloo Y. A Narrative Review of Childhood Picky Eating and Its Relationship to Food Intakes, Nutritional Status, and Growth. *Nutrients.* 2018;10:1–30.
- [7] Walton K, Kuczynski L, Haycraft E, Breen A, Haines J. Time to re-think picky eating ?: a relational approach to understanding picky eating. *Int J Behav Nutr. International Journal of Behavioral Nutrition and Physical Activity;* 2017;1–8.
- [8] Khaq AE, Yuniastuti A, Rahayu SR. An Analysis of Picky Eater Towards Growth and Motor Development at Kebasen District Health Centre. *Public Heal Perspect J.* 2018;3:224–30.

- [9] Emmett PM, Hays NP, Taylor C. Antecedents of picky eating behavior in young children. *Appetite*. 2018;163–73.
- [10] Yen HTB, Huong LT, Thang V Van, Tien HA. Picky Eating and Nutritional Status among Vietnamese Children Under Five Years of Age in Hue, Central Vietnam. *Biomed J Sci Tech Res*. 2019;11733–9.
- [11] Palfreyman Z, Haycraft E, Meyer C. Original Article Development of the Parental Modeling of Eating Behavior Scale (PARM): links with food intake among children and their mothers. *Matern Child Nutr*. 2014;617–29.
- [12] Sogari G, Velez-Argumedo C, Gómez MI, Mora C. College students and eating habits: A study using an ecological model for healthy behavior. *Nutrients*. 2018;10:1–16.
- [13] Lyons M. Children's Picky Eating and the Role of Family Environments. *J Undergrad Res*. 2015;15.
- [14] Savage JS, Fisher JO, Birch LL. Parental influence on eating behavior. *J Law, Med Ethics*. 2007;35:22–34.
- [15] Taylor CM, Wernimont SM, Northstone K, Emmett PM. Picky/fussy eating in children: Review of definitions, assessment, prevalence and dietary intakes. *Appetite*. Elsevier ,Ltd; 2015;95:349–59.
- [16] Chao H. Association of Picky Eating with Growth, Nutritional Status, Development, Physical Activity, and Health in Preschool Children. *Front Pediatr*. 2018;6:1–9.
- [17] Xue Y, Zhao A, Cai L, Yang B, Szeto IMY, Ma D. Growth and Development in Chinese Pre- Schoolers with Picky Eating Behaviour: A Cross-Sectional Study. *PLoS One*. 2015;1–16.
- [18] Kwon KM, Shim JE, Kang M, Paik H. Association between Picky Eating Behaviors and Nutritional Status in Early Childhood: Performance of a Picky Eating Behavior Questionnaire. *Nutrients*. 2017;9.
- [19] Knaap I van der. The determinants of sex differences in child stunting in Sub Saharan Africa: a multilevel logistic Sub-Saharannalysis. 2018.
- [20] Wamani H, Åström AN, Peterson S, Tumwine JK, Tylleskär T. Boys are more stunted than girls in Sub-Saharan Africa: A meta-analysis of 16 demographic and health surveys. *BMC Pediatr*. 2007;7:1–10.
- [21] Scaglioni S, Cosmi V De, Ciappolino V, Brambilla P, Agostoni C. Factors Influencing Children's s Eating Behaviours. *Nutrients*. 2018;1–17.
- [22] Bandura A. Social learning: Theory. *Gen. Learn. Press*. 1971. p. 1–46.

Measuring Customer Satisfaction on Small-Scale Sport Event: A Case Study of The Sport Event Organizer Subject's Final Project

Billy Castyana¹, Tandiy Rahayu², Rumini³, Mugiyo Hartono⁴,
Dwi Gansar Santi Wijayanti⁵, Wahyu Ragil Kurniawan⁶
{billycastyana@mail.unnes.ac.id¹, tandiyorahayu@mail.unnes.ac.id², rumini@mail.unnes.ac.id³}

Department of Physical Education Universitas Negeri Semarang, Semarang, Indonesia^{1,2,3,4,5,6}

Abstract. The aim was to measure the customer satisfaction on small-scale sport event conducted by students. This quantitative descriptive study was conducted using survey method with population came from the participants of sport events throughout Central Java and were chosen by accidental sampling with 141 respondents. Survey consists of Tangible, Empathy, Responsiveness, Reliability, and Assurance in the form of checklist by using Likert scale 1 to 4. From the results of data processing, researchers found that 75% of participants said the committee is reliable. Then 75.18% of participants stated the organizer is responsive. The data also shows 76.60% of participants mention how assure they are due to organizing committee could build a good trust among them. Then 77.48% of participants said that the empathy addressed by the committee was in accordance with the participants' expectations and 80.32% of the tangible factors were given by organizer make participants will participate again.

Keywords: sport event organizer, customer satisfaction, sport management.

1 Introduction

Sport events are an entertaining physical activities that have a creative and complex character, including an impact on improving tourism and socio-economy for a region[1]. Various countries are currently competing to host large-scale sport events, such as the Olympics, Asian Games, World Cup, etc. However, many do not pay attention that holding small-scale events has the potential to have a large impact on local communities[2]. The small-scale sport event itself is a sporting event which is organized by involving a small sports fan base that is held routinely at both the regional and national levels[3]. Small-scale sports events like this are able to provide benefits in the local economy, tourism, cheap entertainment for the community, and enhancing community pride[4]. Small-scale events also have the advantage of being easy to manage and the implementation does not incur large costs so that events like this can avoid the negative impact of organizing mega events[2]. To maximize this potential, the organizing committee must be able to provide satisfaction during the event. In its implementation, the most benefi-

cial thing is to give satisfaction to the sports fans because until now sports fans have a big role in the success of the event[5]. They are willing to spend money to be able to watch directly or indirectly through other media.

From previous studies, it can be concluded that customer satisfaction is an evaluation of what is felt by customers and whether the services provided are in line with expectations[6]. Customer satisfaction is the key to the loyalty of sports fans and this will make them provide a beneficial relationship with the event organizer[7]. In addition, customer satisfaction can also be interpreted as how customers evaluate the performance of event organizers and later the results of these evaluations can show how the level of customer satisfaction[8]. According to that statement, it means the event organizer must improve the quality of service and set prices according to the services received so that customers will be satisfied[9]. If this can be realized, it will affect the desire to re-join the event, invite more people to participate, bring up positive reviews, so that the event organizer can compete with other event organizing competitors[10]. It should be noted that the ability to be able to provide satisfaction to customers will determine the difference between one event with another event and can build customer loyalty relationships[11].

To build customer satisfaction, sport event organizer must understand how to provide services to customers, this is called service quality. When viewed from an economic point, the services provided must meet customer desires because the service will determine how the evaluation provided by the customer on their level of satisfaction[12]. In addition, from a social standpoint, services must be provided to customers on reasonable grounds[6]. From this opinion, it can be concluded that service is an activity that provides customer support systems, handling complaints, speed in handling complaints, ease in reporting complaints, and friendliness in receiving complaints[8]. Previous research has shown that when customers don't get good service when they report complaints, that's when they start switching to other brand[13]. In addition, the friendly and polite attitude of the organizers of events related to service will give a positive impression that can make customers satisfied[14].

Quality of service has ten requirements to be met, namely reliability, responsiveness, tangibles, communication, credibility, security, competence, courtesy, ability to understand customers, and customer access to services. However, if you look at the service quality scale (SERVQUAL), there are five dimensions that must be met, including reliability, responsiveness, assurance, empathy and tangibles[15] This measurement model is a tool commonly used to measure service levels and differences in customer satisfaction. Reliability is an ability to deliver what the organizer promises to customers. Responsiveness is how the organizer is prepared to provide good service. Assurance is the organizer's ability to build trust in customers. Emphaty is caring and prioritizing service to customers and how organizers are able to translate what customers want. The last dimension is Tangible, this dimension shows how facilities are used, how to communicate, and how to provide services to customers[16]

Since 2017, Department of Physical Education, Universitas Negeri Semarang includes material about sport event organizers as a part of curriculum. The final task of this course, students are required to be able to conduct small-scale sport events in various regions in Central Java. Over the past two years, the success of students in organizing sport events has been extraordinary because in addition to the knowledge they get directly in the field, they also get financial benefits ranging from Rp. 750,000 to Rp.

11,000,000. This certainly cannot be separated from the performance carried out by the committee to make customer satisfied. With many sports events had been conducted by students, it needs to have a further study to understand the customer satisfaction within the event. This research conducted to know how satisfy consumers are with the performance of the existing committee, whether the implementation of the event is in accordance with the expectations of the participants, and whether the services provided are good enough. This study aims to measure the customer satisfaction on small-scale sport event conducted by students so that it becomes a feedback for the implementation of the next event.

2 Methods

This quantitative descriptive study was conducted using survey method. Population came from the participants of sport events throughout Central Java which conducted by Physical Education students and were chosen by accidental sampling with 141 respondents. They were asked using a 4-point Likert Scale modification of SERVQUAL instrument consist of reliability, responsiveness, assurance, empathy and tangible, which was adopted with a slight modification[17].

Table 1. Servqual questionnaire.

Indicators	Question
Responsiveness	The committee is responsive in providing services during the event
	The committee responses all complaints regarding the activities friendly
	The committee is able to provide solutions to every problem regarding the event
	The committee provides the best service from the beginning to the end of the event
	The committee is running event on schedule
Assurance	The event is going well
	The services provided by the committee are good
	The committee is polite during the event
	The committee is friendly towards all participants
	The committee can be trusted
Tangible	Existing facility supports the ongoing sport event.
	Existing facility is sufficient to conduct sport event.
	The Sport Hall is quite spacious and sturdy.
	The location of sport hall is quite strategic.
Emphaty	All committees look neat, attractive and polite.
	It is easy to register as a participant
	There is a clear explanation related to facility
	The committee provides good service to participants
	In general the committee provided the needs of the participants during the event
Reliability	Participants can give feedback both written and oral
	The committee always helps participants in facing difficulties during the event
	The committee is able to solve problems quickly
	The committee is responsible for all activities

The committee is fast and proper in providing services during the event
 The committee provides clear information to participants

Before the survey began, Physical Education students already conducted sport event at 7 regions in Central Java. The respondents were received the questionnaire after they finished their participation on the entire series of events, and during they filled out the questionnaire they were accompanied by the research team to assist if there were any difficulties.

3 Result and discussion

3.1 Result

After data collection was carried out in 7 regions, namely Banyumas, Tegal, Kendal, Blora, Kudus, Temanggung, and Wonosobo, the data was then processed to get an overview of the level of customer satisfaction at the event. From the results of data analysis, researchers found that 76.91% participants satisfied with the organizer. However, if we focused on each indicators, 75% of participants said the committee is reliable. Then 75.18% of participants stated the organizer is responsive. The data also shows 76.60% of participants mention how assure they are due to organizing committee could build a good trust among them. Then 77.48% of participants said that the emphaty addressed by the committee was in accordance with the participants' expectations and 80.32% of the tangible factors were given by organizer make participants will participate again.

Table 2. Servqual Percentage Analysis.

Factors	Average	Percentage (%)
Responsiveness	3.00	75
Assurance	3.01	75.18
Tangible	3.06	76.60
Emphaty	3.10	77.48
Reliability	3.21	80.32

3.2 Discussion

In the data shown in table 1, it can be seen how satisfying the implementation of sports events conducted by Physical Education students. This satisfaction is inseparable from the factors were successfully met by the committee, such as committee performance, event execution, service quality, and committee attitudes, which eventually made the participants would like to participate again. In addition, these results also have interference from lecturers who guide and control them. How students learn the science of organizing sports events in class and applying them in the field is an integral part.

Consumer satisfaction is closely related to the suitability of service between expectations and reality that consumer receive[18]. Consumers can feel satisfaction if what is promised and expected by them can be fulfilled. From the five dimensions it can be seen that customer satisfaction has a high percentage. However, responsiveness has a lowest

percentage among them, it means that the event organizer had not prepared the activity properly so there were still problems in service to customers. There was also time when the committee confused when there were questions from customers. To improve it, organizer needs to conduct a training so that the committee is ready when faced with conditions on the ground. This training has an important role in the achievement of organizing events because it can make the committee work more efficiently and effectively[19]. Especially when the committee that works does not have much experience even though they already have knowledge, but the quality of the performance depends on three things, namely experience, knowledge, and management[20].

As the highest percentage of customer satisfaction, the reliability is shown that the committee succeeded in realizing the expectations of the customers. Reliability has two important factors namely consistency and dependability. Consistency shows how the committee can work together in a single unit in a compatible manner and make the quality of service the same standard. Dependability shows the certainty of the committee to be able to show services in accordance with customer expectations and increase trust in the organizer. From these two factors, it can be found the reasons why customers are satisfied with the performance of the committee[21].

In the first factor, consistency, the committee proves that they have the same standard in treating customers. Starting from the beginning of registration and the same payment system until the time of the event where the committee made a group chat as a communication medium so that all customers get the same information. Based on the second factor, dependability, committee showed good service when customers feel confused in the payment process, registration, until when they have a complaint. This made the committee succeeded in building customer trust. On the opposite hand committee ought to perceive in each event, issues and protests from participants are inevitable. The ability of the committee to resolve issues quickly is also a matter of thought whether participants would like to rejoin the event or not. The committee should be able to show participants that they are reliable individuals in breakdown problems quickly. They need to make sure the neutrality in providing solutions and be ready to be liable for all choices taken. Therefore, the committee is needed to possess a sense of belonging so all committees would be one in solving issues. The committee is additionally needed to not offer solutions to issues that do not seem to be their domains due to inaccurate info that causes additional issues. By delegating the matter to the correct committee, it will provide the proper answers and therefore the performance showed by the committee is better.

Performance also has a relation with how committee will run the event. During the event the committee must ensure that the rundown event that has been shared with the participants is carried out appropriately. If there is a delay or change in schedule, the committee must notify the participants as soon as possible so that participants do not wait or are late to attend. Therefore, the committee must have a Liaison Officer (LO) to become a contact person. Besides, participants also expect that there will be a suitability of service with the price paid to become a participant. Appropriate exchange of values is important because the committee must hold the principle even though the customer is wrong, they are always right. The committee has the responsibility to provide services to the maximum extent possible in accordance with the amount of value paid by participants. It is the power to meet the committee guarantees properly and equally, like customer service is not difficult, particularly throughout registration and simply to urge info. Therefore, the committee must have good communication among them and with the

participants, such as no different information between committee and giving warm attitude to participants when they ask and give complain, especially information regarding the facilities provided by the institution and those available on venue.

Another thing that must be considered is the committee's attitude to the participants, including how the committee reacts to the criticism and suggestions from participants. The committee must be friendly to all participants without exception, because participants are customers and the sustainability of an event depends on customer satisfaction. The committee must have empathy for the participants who are not just politeness and friendliness in serving customers, but rather a commitment to customers, willingness to understand their needs carefully, and trying to fulfill them. If applied in the event, it can take the form of attention to customer complaints regardless of social status.

This research is part of research about factors that influence the performance of sport event organizers. This research was conducted to provide input on how sports events should be held and how to become a good sports event committee.

References

- [1] Bjelac, Z., & Radovanovic, M. (2003). Sports events as a form of tourist product, relating to the volume and character of demand. *Journal of Sport tourism*, 8(4), 260-269.
- [2] Tzetzis, G., Alexandris, K., & Kapsampeli, S. (2014). Predicting visitors' satisfaction and behavioral intentions from service quality in the context of a small-scale outdoor sport event. *International Journal of Event and Festival Management*.
- [3] Gibson, H. J., Willming, C., & Holdnak, A. (2003). Small-scale event sport tourism: Fans as tourists. *Tourism management*, 24(2), 181-190.
- [4] Gibson, H. J., Kaplanidou, K., & Kang, S. J. (2012). Small-scale event sport tourism: A case study in sustainable tourism. *Sport management review*, 15(2), 160-170.
- [5] Lee, J. S., & Kang, J. H. (2015). Effects of sport event satisfaction on team identification and revisit intent. *Sport Marketing Quarterly*, 24(4), 225.
- [6] Hanif, M., Hafeez, S., & Riaz, A. (2010). Factors affecting customer satisfaction. *International research journal of finance and economics*, 60(1), 44-52.
- [7] Eshghi, A., Haughton, D., & Topi, H. (2007). Determinants of customer loyalty in the wireless telecommunications industry. *Telecommunications policy*, 31(2), 93-106.
- [8] Kim, M. K., Park, M. C., & Jeong, D. H. (2004). The effects of customer satisfaction and switching barrier on customer loyalty in Korean mobile telecommunication services. *Telecommunications policy*, 28(2), 145-159.
- [9] Gustafsson, A., Johnson, M. D., & Roos, I. (2005). The effects of customer satisfaction, relationship commitment dimensions, and triggers on customer retention. *Journal of marketing*, 69(4), 210-218.
- [10] Anderson, E. W., Fornell, C., & Mazvancheryl, S. K. (2004). Customer satisfaction and shareholder value. *Journal of marketing*, 68(4), 172-185.
- [11] Deng, Z., Lu, Y., Wei, K. K., & Zhang, J. (2010). Understanding customer satisfaction and loyalty: An empirical study of mobile instant messages in China. *International journal of information management*, 30(4), 289-300.
- [12] Turel, O., & Serenko, A. (2006). Satisfaction with mobile services in Canada: An empirical investigation. *Telecommunications policy*, 30(5-6), 314-331.
- [13] Ahn, J. H., Han, S. P., & Lee, Y. S. (2006). Customer churn analysis: Churn determinants and mediation effects of partial defection in the Korean mobile telecommunications service industry. *Telecommunications policy*, 30(10-11), 552-568.
- [14] Söderlund, M., & Rosengren, S. (2008). Revisiting the smiling service worker and customer satisfaction. *International Journal of Service Industry Management*.

- [15] Loke, S. P., Taiwo, A. A., Salim, H. M., Downe, A. G., & PETRONAS, U. T. (2011). Service quality and customer satisfaction in a telecommunication service provider. In *International conference on financial management and economics* (Vol. 11, No. 2, pp. 23-29).
- [16] Bhat, M. A. (2012). Tourism service quality: A dimension-specific assessment of SERVQUAL. *Global Business Review*, 13(2), 327-337.
- [17] Theodorakis, N. D., Kaplanidou, K., & Karabaxoglou, I. (2015). Effect of event service quality and satisfaction on happiness among runners of a recurring sport event. *Leisure Sciences*, 37(1), 87-107.
- [18] Hult, G. T. M., Cavusgil, S. T., Calantone, R. J., Day, G., Wansink, B., van Ittersum, K., ... & Lehmann, D. (2003). Knowledge as a strategic resource in logistics and purchasing (pp. 1-20). Marketing Science Institute.
- [19] Latham, G. P. (2011). Human resource training and development.
- [20] Amisano, C. (2010). eHow contributor "Relationship between training and employee performance". Available on the website: <http://hrcouncil.ca/hr-toolkit/learningimplementing.cfm>.
- [21] Gunawardane, G. (2011). Reliability of the internal service encounter. *International Journal of Quality & Reliability Management*.

Support and Obstacles for Pregnant Woman Class in Sukoharjo, Indonesia: A Qualitative Study

Burhannudin Ichsan¹, Harsono Salimo², Ari Probandari³, Eti Poncorini Pamungkasari⁴
{bi268@ums.ac.id¹, profharsono2612@gmail.com², ari.probandari@staff.ums.ac.id³}

¹Medical Faculty, Universitas Muhammadiyah Surakarta, Indonesia

²Public Health Doctoral, Universitas Sebelas Maret Surakarta; Department of Pediatric, Faculty of Medicine Universitas Sebelas Maret Surakarta, Indonesia

^{3,4}Public Health Doctoral, Universitas Sebelas Maret Surakarta; Department of Public Health, Faculty of Medicine Universitas Sebelas Maret Surakarta, Indonesia

Abstract. Pregnant woman class is a class of pregnant women with gestational age between 20 to 32 weeks. The aim is to reduce maternal and infant mortality. The class is facilitated by midwife/health worker. This qualitative study evaluated the course of the class in Sukoharjo. The results showed that the class had gone quite well, but the quality needed to be improved. Six categories were found, namely: 1) In general, the pregnant woman class was running well, 2) the pregnant woman class was not fully interactive, 3) the physical and moral support of the government for the pregnant woman class, 4) funds, time and technical constraints in the pregnant woman class, 5) the interaction between mother and midwife was needed to be improved, and 6) obstacle to practice meeting material from family. The pregnant woman class in Sukoharjo was running well, but the quality was still needed to be improved.

Keywords: Pregnant woman class, Sukoharjo, Evaluate, Qualitatif study

1 Introduction

SDG3 targets include reducing global MMR to no more than 70 maternal deaths per 100,000 live births by 2030, with an additional national target that no country has an MMR greater than 140 per 100,000 live births, and reducing neonatal mortality to no more than 12 infant deaths per 1,000 live births in 2030 [1]. One of the priorities in the health development program in Indonesia is an effort to improve the health status of mothers and children. Some groups who are vulnerable to health are pregnant women and babies during the perinatal period. This can be seen by the high maternal mortality rate (MMR) and infant mortality rate (IMR) [2]

Indonesia has a high maternal mortality rate when compared to maternal mortality rates in other countries in ASEAN. In 2015, the maternal mortality rate in Indonesia was 305 / 100,000 live births, while the neonatal mortality rate in Indonesia was 15 / 1,000 live births [3].

At present, there are still many counseling on maternal and child health individually and are based on a case by case. This has several weaknesses, including: 1) health knowledge obtained is only a problem faced during consultations, 2) lack of coordination, so knowledge is limited to the staff's knowledge, 3) there is no work plan so there is no monitoring and good guidance, and 4) implementation of unscheduled and unsustainable counseling [2]. Being a parent is a life transition that can be confusing [4]. For this reason, a class of pregnant women is needed [2].

The pregnant woman class has the aim to increase the knowledge, attitudes and behavior of pregnant women. Some of the scope of the material is body changes during pregnancy, complaints during pregnancy and how to overcome them, danger signs of pregnancy, and regulation of nutrition during pregnancy [5].

Evidence-based practice must be complemented by evidence-based implementation [6]. This research is a qualitative research aiming to evaluate the implementation of pregnant woman class in Sukoharjo, Central Java, Indonesia. The results of this study are expected to be able to identify feasibility and obstacles so that they can be the basis for improvements the program.

2 Method

2.1 Research setting

This research was conducted in Sukoharjo district, Central Java, Indonesia. There are public and private sectors that provide health services in Sukoharjo district. The public sector consists of district health offices and community health centers which are extensions of the district health offices to carry out their functions. The community health center coordinates, plans, implements and evaluates health programs in the community. Pregnant women classes are carried out by community health centers. Generally, pregnant woman class facilitators are midwives.

2.2 Research design and sampling method

This qualitative research aim to evaluate the pregnant woman class in Sukoharjo. The sampling technique was purposive sampling. The informants consisted of: 1) mothers who had been a member of the pregnant woman class, and 2) midwives who were facilitators of the class. The informants consisted of 11 mothers and 4 midwives.

2.3 Data collection

In-depth interviews were conducted from August to September 2019. The interviews used a semi-structured questionnaire. Interview topics include: a) what supports to the pregnant woman class, and b) anything that inhibits the pregnant woman class.

Interviews were conducted at home for mothers. Interviews were conducted at the community health center for midwives. Interviews were conducted using Indonesian. Data collection were also done by observation. The author attended several classes to see the course of the class.

2.4 Data analysis

Records of interviews were changed to verbatim transcripts. The analysis used was content analysis. After reading all the transcripts, the author then identifies the meaning units. Meanings units were summarized as condensed meanings units. Code was obtained from the condensed meaning unit. Codes that lead to the same thing became categories. From similar categories, a theme will emerge which was a meaning that linked all the categories found.

2.5 Reliability (trustworthiness)

The credibility and reliability of this analysis used triangulation. Source triangulation was conducted by interviewing various informants from various positions, namely baby mothers and midwives. Method triangulation was conducted by using more than one method, namely in-depth interviews and observation.

2.6 Etichal clearance

Ethical clearance was obtained from Sebelas Maret University Etichal clearance committee. Presentation of results were displayed anonymously.

3 Results

The theme of support and obstacles for pregnant woman class in Sukoharjo reflects that the class has run smoothly, although there were still some obstacles. The theme is a summary of six categories, namely: 1) In general, the pregnant woman class was running well, 2) the pregnant woman class was not fully interactive, 3) the physical and moral support of the government for the pregnant woman class, 4) funds, time and technical constraints in the pregnant woman class, 5) the interaction between mother and midwife need to be improved, and 6) obstacle to practice meeting material from family.

The pregnant woman class in Sukoharjo is going well, but there are some obstacles that need attention. The existing constraints can cause the program to be less than optimal.

3.1 Supports of pregnant woman class in general, the pregnant woman class was running well

The findings indicate that in general the pregnant woman class runs well. This can be seen from several indicators: 1) mothers like to attend the meeting, 2) mothers are enthusiastic and pay attention to the material, and 3) in general, classes run smoothly.

The four indicators can be seen from both the observation and the results of in-depth interviews with informants. "... these mothers are very enthusiastic. They don't need to be forced. They are just waiting for the next meeting schedule "(midwife, 36 years). "... I see they are serious and pay attention" (midwife, 36 years). "... yes, can understand the material" (pregnant women, 24 years). "... all pregnant women can attend and the meeting goes well" (midwife, 47 years).

The physical and moral support of the government

There were physical and moral support from the government. Physical support included physical facilities and financial support. Moral support was the visit of the wife's

village head. Although the presence of the wife's village head was not routine, this has been good motivation for pregnant women.

The following are some examples that show support from the government. "... yes, the place is in the village polyclinic owned by the village government" (midwife, 44 years). "... at the time of implementation, the wife's village head always accompanied" (midwife, 32 years). "... now, the pregnant woman class has received support from the village government" (midwife, 36 years).

3.2 Obstacles of pregnant woman class

The pregnant woman class was not fully interactive

Pregnant woman class is expected to run interactively. Research findings show that classes sometimes were interactive, sometimes were passive. This is indicated by the results of observations which show that midwives dominate the meeting, and participants tend to be passive.

Observation results indicate that midwives try to make the class interactive. The midwife ordered mothers to take turns reading. The observations also showed that some mothers tried to ask the midwife. The results of the following interviews indicate that some participants were actively involved. "... yes, there are questions and answers" (baby mother, 24 years). A midwife also said that sometime mothers were actively involved in counseling. "... they actively ask questions in meetings" (midwife, 36 years).

Funds, time and technical constraints

As the other health programs, the pregnant woman class have some obstacles too. Some of the obstacles found in this study were: 1) funding constraints, 2) time constraints, and 3) technical constraints.

Funding constraints were the perceived lack of funds for administering these classes. An interview with a midwife revealed as follows. "... only runs four times a year, because the funds are only from the village government budget (midwife, 34 years).

The time constraints found in this study were lack of time discipline and attendance constraints because pregnant women work. The results of an in-depth interview with a pregnant woman showed that they waited for each other. "... the obstacle was that the time is not right, because there is one coming home from work" (pregnant woman, 23 years). Constraints of pregnant women which coincided with work time was revealed by one of the midwives as follows. "... the obstacle was because there were working mothers who could not attend the class " (midwife, 34 years).

The technical constraints of the class of pregnant women included: 1) books that were rarely read, and 2) pregnant women were accompanied by children when attending meetings. The following in-depth interviews show that books were rarely read. "... books were rarely read, sir" (baby's mother, 24 years old). The results of observations and in-depth interviews showed that pregnant women were often accompanied by children when attending counseling. "... when I attend a meeting, I was accompanied by my child" (pregnant woman, 23 years).

The interaction between mother and midwife need to be improved.

There was interaction between the baby's mother and the midwife, both when the meeting schedule and when the pregnant mothers class program was finished. The interac-

tion between mother and midwife needed to be increased. Evidence that interactions between mothers and midwives was needed to be increased could be seen from the following expression. "...rarely. If I didn't check my baby with a midwife, we didn't interact" (baby's mother, 24 years old).

Obstacle to practice meeting material from family.

Grandmother's persuasion to mothers to give other liquid than breast milk before the baby was 6 months old was revealed by a midwife as follows. "... because the baby was often fussy, baby's grandmother ordered formula milk" (midwife, 34 years). Persuasion from the husband was shown by the statement of the mother as follows "... the husband asked to give formula milk, when the baby cried" (baby's mother, 24 years).

4 Discussion

The results of this study indicated that the pregnant woman class in Sukoharjo has run quite well. This finding was also related to other findings in the form of support from the government. Government support in the form of moral and physical support. There were several obstacles in the implementation of the class. Some related studies are as follows.

Nurdiyana et al. (2015) conducted a study to look at the course of pregnant woman class in the Malalak and Biaro community health centers, Agam district, Indonesia. The results showed that the implementation of the class was not in accordance with the guidelines for implementing the class issued by the Ministry of Health of the Republic of Indonesia. Various efforts were needed to optimize and develop the implementation of the class [7].

Dahlan et al. (2018) conducted a study to look at the course of pregnant woman class in Padang city community health centered. The results showed that the implementation of the class of pregnant women had not run optimally. There were still weaknesses both in terms of input, process and output. Community health center needed to conduct periodic evaluations regarding the achievements and indicators of success of pregnant woman class [8].

Barimani et al. (2018) conducted a study to see the course of ante natal classes given to parents in Sweden. The study was conducted in two antenatal care units in a large city in Sweden. Sweden has a long tradition of antenatal classes, which were offered to parents who are having their first child. Ante natal classes were held at the end of pregnancy. About 70% of parents attended antenatal classes. Midwives who work in the antenatal care unit lead the class. The style of facilitation and focus of the material varied. The results showed that about 67 percent of the material was related to labor preparation and the topic of pain relief. Conversely, parents were more interested in baby care, breastfeeding, and child care. Participants also often reflected on one another over several topics such as child problems, marital relations, sex, and anxiety. Both male and female participants actively listened to the midwife. They also seem receptive to complex problems, and they required a lot of time to ask. Participants appreciated the ante natal class [4].

Al Otaiby et al. (2013) conducted a study to analyze the knowledge and preferences of mothers towards ante natal education. The study was conducted by distributing questionnaires to see knowledge scores, preferred education formats, preferred education pro-

viders, preferred educational strategies, and preferred material content. The results showed that: 1) low level of knowledge, 2) the most preferred material form was written form, followed by one-on-one face-to-face education, 3) doctors were the most preferred material providers, 4) preferred educational strategies were motivation, support, guidance, problem solving, and what should be and are prohibited, and 5) the material chosen is a sign of pregnancy and maintenance after birth [9].

Miquelutti et al (2013) reported the qualitative study to see the experience the women had participated birth preparation program. The results showed that women participating the birth preparation program reported self control during labor and used non pharmacological techniques in controlling pain and facilitating labor. They also expressed satisfaction with the birthing experience. Women who did not participate the program reported difficulties in maintaining control during labor and almost half of them reported lack of control [10].

The results of research on evaluating classes of pregnant women show generally unsatisfactory results. This has similarities with the results of this study, but the difference in the results of this study shows that in general the class of pregnant women has been going well but there were some obstacles.

The results of this study indicated that the interactivity of the participants was not good. The results of a study of ante natal classes in Sweden showed that participants were actively involved in the education program. This might be caused by cultural differences.

The results of this study also indicate the need to increase interactivity between the facilitator and the participating mothers. These results are quite in line with the findings of Barimi et al. (2018). Barimi et al. (2018) found that the facilitator needed to give more time to give participants the opportunity to ask for material that was of interest to the participants. But the difference, Barimani et al (2018) found that the meeting was interactive, but still felt less by the participants[4].

Implementation of public health program can succeed and be sustainable if organizations and coalitions effectively address six key things: innovation, a rigorously established technical package, management, partnerships, communication, and political commitment [11].

The Sukoharjo government, particularly the health department, can carry out periodic evaluations and monitoring of the course of pregnant woman class. This research can be used as one of the considerations to improve the program. Evaluation research that combines qualitative and quantitative methods is needed. The results of the mixed methods research are expected to provide a more comprehensive picture.

5 Limitation

This research has not been able to analyze the real impact such as maternal mortality rates and infant mortality rates.

6 Conclusion

The pregnant woman class was going well. The government supported the pregnant woman class. Pregnant women classes have not been fully interactive. The interaction of

the facilitator and mothers were still needed to be improved. There were still obstacles from the family, when the mother would practice the material provided in the class.

References

- [1] Hodin, S. M., Caglia, J. M., Baye, M., Bewa, J., Waiswa, P., & Langer, A. 2016. Commentary: From MDGs to SDGs: implications for maternal newborn health in Africa. *Africal Journal of Reproductive Healt*. September (Spesial edition on SDGs). 20(3):26.
- [2] Republik Indonesia Ministry of health. 2014. Guidelines for implementing pregnant woman class. Available: <http://kesga.kemkes.go.id/images/pedoman/pedoman%20kelas%20ibu%20hamil.pdf>. Accessed: June 26, 2020.
- [3] Achadi, E.L. 2019. Maternal and neonatal mortality in Indonesia. Available: <http://www.kemkes.go.id/resources/download/info-terkini/rakerkesna-2019/SESI%20I-ke-lompok%20I-1-kematian-maternal-dan-neonatal-di-Indonesia.pdf>. Accessed: June 26, 2020.
- [4] Barimani, M., Frykedal, K.F., Rosander, M., & Berlin, A. 2018. Chilbirth and parenting preparation in antenatal classes. *Midwifery*, 57. 1-7. <https://doi.org/10.1016/j.midw.2017.10.021>.
- [5] Andriani, Y., Respati, S.H., & Astirin, O.P. 2016. Effectiveness of pregnant woman class in the prevention of pregnancy anemia in Banyuwangi, East Java. *Journal of Maternal and Child Health*, 1(4): 230-241. <https://doi.org/10.26911/thejmch.2016.01.04.04>.
- [6] Powell, B. J., Fernandez, M. E., Williams, M. J., Aarons, G. A., Beidas, R. S., Lewis, C. C., McHugh, S. M., & Weiner, B. J. 2019. Enhancing the impact of implementation strategies in healthcare: a research agenda. *Front. Public Healt*. Vol 7, article 3. doi: 10.3389/fpubh.2019.00003
- [7] Nurdiyan, A., Desmiwati., & Machmud, R. 2015. Analysis of pregnant woman class implementation in Malalak and Biaro community health center, Agam District. *Jurnal Kesehatan Andalas*, 4(1).
- [8] Dahlan, A., Marlia, S., & Herien, Y. 2018. Analysis of the pregnant woman class implementation in Padang city community health center. *UJSR*. Vol. 3, issue 2, Dec: 218-227.
- [9] Al Otaiby, T., Jradi, H., & Bawazir, A. 2013. Antenatal education: an assessment of pregnant woman knowledge and preferences in Saudi Arabia. *J Women's Health Care*, Vol 2, Issue 4. DOI: 10.4172/2167-0420.1000139.
- [10] Miquelitti, M. A., Cecatti, J. G., & Macuch, M. Y. 2013. Antenatal education and the birthing experience of Brazilian women: a qualitative study. *BMC Pregnancy and Chilbirth*. 13:171.
- [11] Frieden, T. R. 2014. Six components necessary for effective public health program implementation. *Am J Public Health*.104:17–22.doi:10.2105/AJPH.2013.301608..

Validity and Reliability Test of The Physical Exercise Movements Screening to Improve Fitness for Elderly

Cerika Rismayanthi¹, Sugiyanto², Agus Kristiyanto³, Muchsin Doewes⁴
 {cerikafik@gmail.com¹, sugiyantoprobo@gmail.com², aguskriiss@yahoo.co.id³}

Universitas Sebelas Maret Surakarta, Surakarta, Indonesia^{1,2,3}

Abstract. Increased age experienced by each person will end with elderly age group, which is vulnerable to various activities due to physiological function decrease occurred. Instead of socio-psychological aspects, muscular function, cardiovascular, balance and mobility aspects are important factors that support our bodies work. The assessment in this study use the questionnaire of "Appropriate Movement for the Elderly" distributed to personal trainers for elderly. The results of the validity and reliability test can be concluded that questionnaire about screening exercises that are suitable for the elderly prove is consistent for all questions and valid for 40 movements, while 7 other movements (pressing the arm in front of the chest, Hyper-extension, Knee wrists to the left and right chest, Russian paw, Turn the arm in the direction of the needle clock, Cow Cat Attitude, and Raise sumo, raise calf on the wall) were invalid or not suitable for physical activities in elderly.

Keywords: physical activity, elderly, questionnaire, validity, reliability.

1 Introduction

The last development period in human life is in the old ages. Called development here does not mean development as experienced by adolescents. What is meant is psychological and social development. In this case the task of development in the elderly is the achievement of integrity in a person. This means that he managed to fulfill commitments in relations with himself and others, accepting the continuation of his age, accepting the limitations of his physical strength, maybe also accepting the illness he suffered. Instead he can also accept any other people's treatment of himself which is actually a reflection of his treatment to other people. If a person cannot achieve integrity, then he will experience discouragement. In addition, the task of developing the elderly is about moral commitment. The elderly should have a commitment to feel capable and have mastery of what they face [2]. Finally, the three commitments mentioned above are good in the struggle for life physically, economically, and psychologically. So it takes socio-psychological abilities in the lives of the elderly to support a variety of skills in old age.

Broadly speaking, the elderly must have a passion in life. In a meta-analysis review of how the elderly respond to their lives, a relationship is found between socio-psychological abilities and the anxiety that surrounds the minds of many elderly people. To overcome anxiety, a statement was obtained that there is a potential relationship to exercise as a therapy for depression or anxiety, and the use of physical activity as a material to improve quality of life through strengthening self-esteem, improving mood, reducing anxiety, resistance to stress and improving sleep quality [6]. So it is required for the elderly to involve physical activity in aspects of improving their lives.

Elderly aged around 50 - 65 years old [15], experiencing various kinds of decreased physiological function, including muscle function, cardiovascular, etc. Muscle strength and power in performing isometric, concentric and eccentric movements decreased since the age of 40 years and a significant decrease occurred after the age of 65-70 years old [14]. Then the balance and mobility factors also decrease when they reach that age [12,14,16]. Based on these considerations, various kinds of movements are needed in accordance with the needs of the elderly. It is certainly cannot be equated with the usual movements carried out by people who are productive in the golden age.

Therefore, the objective of this study was to verify the construct validity and reliability of screening movements for elderly. The validation is needed from experts (in this case personal trainers or elderly instructors) to find out what movements are considered safe, easy and can prevent or slow down the aging process. On the other hand, it can help the elderly confident and be able to do various movements for daily activities.

2 Method

This research uses a mixed-method [4] in order to complement the data obtained, both from qualitative and quantitative data. Qualitative data were obtained through elderly interviews and quantitative data through descriptive research using a "Screening Movements for the Elderly" questionnaire as an instrument.

2.1 The physical exercise movements screening questionnaire

Several processes must be completed to get suitable movement for elderly. In the beginning, searching, finding, implementing theoretically and empirically from previous study to identify problems faced by older adults, which is include field study and need assessment. The next step was early product of training model for elderly, so that prototype research model created at the beginning of research flow. Comprehension and depth of learning literature united with research model prototype will through expert validation. If research model prototype considerably accepted, research model revised, after that, product completed.

The questionnaire was sent into personal trainer, in order to get any suggestion or opinion for improving details of questionnaire. This product (or questionnaire) confirmed by practitioners so that theory and practically blend accepted. Furthermore, screening movements for elderly questionnaire evaluated, implementing all suggestion from expertise, both theory and practical, afterwards got last revised then design finalization of questionnaire. After through all previous steps, validation and reliability of this questionnaire was measured.

2.2 Type of movement

The questionnaire is used to have any exercise movements that are suitable for elderly, and have a small risk of injury or bodily imbalance that can cause falls in the elderly, as shown in Table I.

Table 1. Type of movement

Exercise	No	Movement
Flexibility	G1	Spinal Stretches
	G2	Shoulder stretch
	G3	Lumbar stretches of left and right spine
	G4	Press your arms in front of your chest
	G5	Left and right triceps stretch
	G6	Biceps stretch standing left and right
	G7	Shoulder Gator
	G8	Rhomboid pull
	G9	Stretch the floor lying on your left and right sides
	G10	Scissors Arm
	G11	Child attitude
	G12	Hyperactivity
	G13	Snow Angel upside down
	G14	Knees to the left and right chest
Balance	G15	Russian punter
	G16	Raise your arms while standing
	G17	Raise your arms to the side
	G18	Rotate the arm clockwise
	G19	Rotate the arm counterclockwise
	G20	Triceps extension bent
	G21	Superman and swimmer
	G22	Lift the "Y" floor
	G23	Lift the calf facing the wall
	G24	Donkey kick to the left
	G25	Left and right quadrant exercises
	G26	Bowed body
	G27	Walk While carrying Ball Medicine
Strength	G28	Push up Hold low modification
	G29	Stomach Crunch
	G30	Mountain climber
	G31	Touch Heel
	G32	Abdomen tightening exercises
	G33	Punch
	G34	Raise your hands while standing
	G35	Raise your arms to the side
	G36	Cow Cat Attitude
	G37	Superman and swimmer
	G38	Supine Push Up
	G39	Squat
	G40	Side walk
	G41	Lunge backwards
	G42	Raise the sumo raise the calf on the wall
	G43	Bowed body
	G44	Lift the Stretcher Rest position

Group training	G45	Sit down
	G46	Stand up
	G47	Stand while moving

Movement recommendations for the elderly. (Table footnote)

a.

Questionnaire data analyzed using IBM Statistics 20 to do validity test (Pearson Correlation) and a reliability test (Cronbach's Alpha). After the calculation is complete, the results are obtained that can explain the data from the questionnaire that has been distributed to the personal trainers or instructors.

3 Result and discussion

3.1 Validity test

In this validity test obtained 47 forms of movement that are considered to be carried out by the elderly. However, to find out whether the form of movement is indeed safe and can be carried out by the elderly or not, it is necessary to test the validity of the experts (in this case personal trainers or instructors). Table 1. shows 47 movements that were deemed feasible.

From the data in Table 1, then the validity test is conducted to the experts to find out which movements can be carried out by the elderly. The following results are obtained; Provisions regarding determining whether it is valid or not can be seen from the r table and the Sig. value (2-tailed), it is known that the amount of $N = 9$ (means that $N = 9$ because each movement is validated by 9 personal trainers), then obtained R table = 0.666; with condition, if the value of Sig. (2-tailed) < 0.05 with Pearson Correlation is positive, then the questionnaire items are declared valid.

It can be concluded that, 7 of 47 movements was invalid because of significant value more than 0.05 (p-value: > 0.05), although r value has positive value. Invalid seven movements are: a). G4 (Press the arm in front of the chest) with p-value: 0,650 > 0.05 and r value = 0.176 < 0.666 ; b). G12 (Hyperactivity) with p-value: 0,650 > 0.05 and r value= 0.176 < 0.666 ; c). G14 (Ankle to left and right chest) with p-value: 0,843 > 0.05 and r value = -0.78 < 0.666 ; d). G15 (Russian paver) with p-value: 0,843 > 0.05 and r value = -0.78 < 0.666 ; e). G18 (Turn the arm clockwise) with p-value: 0,650 > 0.05 and r value = 0.176 < 0.666 ; f). G36 (Cow Cat Attitude) with p-value: 0,971 > 0.05 and r value = - 0.14 < 0.666 ; g). G42 (Raise the sumo raise the calf on the wall) with p-value: 0,650 > 0.05 and r value = 0.176 < 0.666 .

As a result of calculating movement validity, we obtained suitable training movements for elderly, it can be seen in Table. II, as follows.

Table 2. Type of movement

Exercise	No	Movement
Flexibility	G1	Spinal Stretches
	G2	Shoulder stretch
	G3	Lumbar stretches of left and right spine
	G5	Left and right triceps stretch
	G6	Biceps stretch standing left and right

	G7	Shoulder Gator
	G8	Rhomboid pull
	G9	Stretch the floor lying on your left and right sides
	G10	Scissors Arm
	G11	Child attitude
	G13	Snow Angel upside down
Balance	G16	Raise your arms while standing
	G17	Raise your arms to the side
	G19	Rotate the arm counterclockwise
	G20	Triceps extension bent
	G21	Superman and swimmer
	G22	Lift the "Y" floor
	G23	Lift the calf facing the wall
	G24	Donkey kick to the left
	G25	Left and right quadrant exercises
	G26	Bowed body
	G27	Walk While carrying Ball Medicine
Strength	G28	Push up Hold low modification
	G29	Stomach Crunch
	G30	Mountain climber
	G31	Touch Heel
	G32	Abdomen tightening exercises
	G33	Punch
	G34	Raise your hands while standing
	G35	Raise your arms to the side
	G37	Superman and swimmer
	G38	Supine Push Up
	G39	Squat
	G40	Side walk
	G41	Lunge backwards
	G43	Bowed body
	G44	Lift the Stretcher Rest position
Group training	G45	Sit down
	G46	Stand up

The seven movements (G4, G12, G14, G15, G18, G36, G42) are declared invalid (p -value > 0.05) so they are not listed in Table 2., while the other 40 movements are considered valid because their significance values are obtained through p -value (Sig. 2-tailed) < 0.05 .

3.2 Reliability Test

This test is intended to find out about the consistency in giving questions that causes instructors to have an ease to answer and have a flow of questions that are easy to understand. The decision making in the reliability test is that 1) if the Cronbach's Alpha value > 0.60 then the questionnaire is presented as reliable or consistent, and 2) if the Cronbach's Alpha value < 0.60 then the questionnaire is presented as unreliable or inconsistent. It can be seen in Table III, the reliability test values obtained are as follows:

Table 3. Reliability Test

Cronbach's Alpha	0.743
------------------	-------

With the Cronbach's Alpha value at $0.73 > 0.60$, it can be concluded that the various types of movements that exist are considered to be reliable or consistent.

3.3 Discussion

Physical activity has an important role in preventing the decline in the body's ability at a young age, maintaining bodily functions, reducing risk factors for disability, helping in checking chronic pain such as heart disease, diabetes, arthritis, or some types of cancer and the development of quality of life [13]. However, due to the great risk of falling in the elderly [16], it takes a lot of exercise movements that are suitable for the elderly in order to be able to support all daily activities of movement.

The results of interviews conducted with the elderly stated that the usual forms of physical exercise include cycling, aerobics and running. The habit of physical activity is carried out routinely three times a week. However, they have limited space to do activities and rarely use additional tools when doing physical activities. Sometimes the elderly experience increased training load, but they feel muscle aches, stiffness, joint pain, pain when bending, stiffness, panting, etc. Therefore, the elderly want practice with slow movements, more fun, more elderly are involved in order to be able to communicate and make the mind become fresher.

So far the elderly assume there is no physical training model that involves sociological and psychological aspects. Constraints faced by the elderly include jumping, bending, lifting weights and coordinating movements of the feet and hands simultaneously.

Then, testing the validity and reliability of the exercise movement screening questionnaire for the elderly is carried out to ensure that when giving activities there is no malpractice that can be dangerous, such as falls, injuries, and freedom of movement. Easy to fall is closely related to body imbalance, the greater the weight of a person the worse the ability to balance the body [7]. From the research results on the validity and reliability of movement screening, 40 movements are obtained as follows;

The number of movements available in Table 2 shows that according to personal trainers or instructors for the elderly, the movement is safe to do, suitable for the elderly. It is starting with a variety of stretching, pulling, balance, muscle strength, etc. The results of interviews with elderly instructors stated that 57.14% of elderly instructors did training with a minimum time of 30 minutes. As many as 5 out of 7 instructors said that the exercises carried out were in accordance with the principle of fitness with low-moderate intensity. Components of fitness in training the elderly include aerobic ability, balance, endurance, strength, flexibility, and speed/ Of course when making movements must be supervised by the instructor, cannot do it alone, because of the high risk of falling [16].

For example, the ability to balance will decrease when weight gain [6], a study in Japan explained that in healthy elderly, a negative relationship with fat condition and waist circumference would be obtained [10]. In other words, more fat deposits and waist width will be positively correlated to the risk of falling in the elderly, but in

healthy elderly with normal conditions of fat and waist circumference, this will minimize the risk of falls.

With the variations in movement choices in Table 3, there is freedom in moving for the elderly in physical activity. But it cannot be denied, 5 out of 7 instructors said that the elderly were having difficulty in doing the movements. The emergence of the difficulty of the elderly in doing the movements resulted in the instructor choosing a way to do a lot of repetition, helping in completing the movements and making the movements simpler, followed by adding weights from one session to the next. When interviewed the elderly also mentioned that as people who are given training, they prefer to do exercises with movements that are easy to do and in the form of games.

In accordance with various previous research that explain physical activity will provide health benefits for the elderly, maintain bodily functions independently [5], improve their quality of life [3], improve posture stabilization and walking patterns in the elderly in reducing the incidence of falls that often occur [12]. Aside from the physical aspects, the elderly also need support from the socio-psychological aspects [11]. With social support from the surroundings, the elderly will have low blood pressure [1], reduce mortality [9], and improve cognitive function [8]. Many instructors argue that there is no physical exercise that combines the socio-psychological aspects with physical activity. The physical training models recommended by the instructors include low-moderate physical activity which is carried out routinely 3 times a week, movements that are easy, simple and pleasant, prioritizing balance and strength.

4 Conclusion

The questionnaire was valid and reliable. Questionnaire regarding screening of exercise movements that are suitable for the elderly have proven to be consistent in the delivery of questions for special instructors in the elderly and are said to be valid for 40 movements, while 7 other movements (Press the arms in front of the chest, Hyperextension, Knees to the left and right chest, Russian twist, turn the arms clockwise, Cow Cat Attitude, and Raise sumo raise calf on the wall) is invalid or not suitable for the elderly to do physical activity.

References

- [1] Birditt, K. S., Newton, N. J., Cranford, J. A., & Ryan, L. H. (2016). Stress and negative relationship quality among older couples: Implications for blood pressure. *Journals of Gerontology - Series B Psychological Sciences and Social Sciences*. <https://doi.org/10.1093/geronb/gbv023>
- [2] Birren, J. E., Warner, K. S., Abeles, R. P., Gatz, M., & Salthouse, T. A. (2006). Handbook of the Psychology of Aging. In *Handbook of the Psychology of Aging*. <https://doi.org/10.1016/B978-0-12-101264-9.X5000-9>
- [3] Cress, M. E., Buchner, D. M., Prohaska, T., Rimmer, J., Brown, M., Macera, C., ... Chodzko-Zajko, W. (2004). Physical activity programs and behavior counseling in older adult populations. *Medicine and Science in Sports and Exercise*. <https://doi.org/10.1249/01.MSS.0000145451.08166.97>
- [4] Donald Ary, Lucy Cheser Jacobs, Asghar Razavieh, C. K. S. (2009). Introduction to Research in Education Eighth Edition. In آب و خاک.

- [5] Evans, W. J., & Grimby, G. (1995). Muscle Performance and Structure in the Elderly as Studied Cross-sectionally and Longitudinally. *The Journals of Gerontology Series A: Biological Sciences and Medical Sciences*. https://doi.org/10.1093/gerona/50a.special_issue.17
- [6] Fox, K. R. (1999). The influence of physical activity on mental well-being. *Public Health Nutrition*. <https://doi.org/10.1017/S1368980099000567>
- [7] Gao, X., Wang, L., Shen, F., Ma, Y., Fan, Y., & Niu, H. (2019). Dynamic walking stability of elderly people with various BMIs. *Gait and Posture*. <https://doi.org/10.1016/j.gaitpost.2018.11.027>
- [8] Gow, A. J., Corley, J., Starr, J. M., & Deary, I. J. (2013). Which social network or support factors are associated with cognitive abilities in old age? *Gerontology*. <https://doi.org/10.1159/000351265>
- [9] Holt-Lunstad, J., Smith, T. B., & Layton, J. B. (2010). Social relationships and mortality risk: A meta-analytic review. *PLoS Medicine*. <https://doi.org/10.1371/journal.pmed.1000316>
- [10] Ito, T., Kawakami, R., Tanisawa, K., Miyawaki, R., Ishii, K., Torii, S., ... Higuchi, M. (2019). Dietary patterns and abdominal obesity in middle-aged and elderly Japanese adults: Waseda Alumni's Sports, Exercise, Daily Activity, Sedentariness and Health Study (WASEDA'S Health Study). *Nutrition*. <https://doi.org/10.1016/j.nut.2018.05.029>
- [11] Kaufman, P., & Wolff, E. A. (2010). Playing and protesting: Sport as a vehicle for social change. *Journal of Sport and Social Issues*. <https://doi.org/10.1177/0193723509360218>
- [12] Messier, S. P., Thompson, C. D., & Ettinger, W. H. (1997). Effects of long-term aerobic or weight training regimens on gait in an older, osteoarthritic population. *Journal of Applied Biomechanics*. <https://doi.org/10.1123/jab.13.2.205>
- [13] Moisescu, P. C. (2014). The Social Integration of Elders Through Free-time Activities. *Procedia - Social and Behavioral Sciences*. <https://doi.org/10.1016/j.sbspro.2014.01.909>
- [14] Porcari, J. P., Bryant, C. X., & Comana, F. (2015). *Exercise Physiology (Foundations of Exercise Science)* 1st Edition.
- [15] WHO. (2016). WHO | Proposed working definition of an older person in Africa for the MDS Project. World Health Organization.
- [16] Yamada, T., & Demura, S. ichi. (2009). Relationships between ground reaction force parameters during a sit-to-stand movement and physical activity and falling risk of the elderly and a comparison of the movement characteristics between the young and the elderly. *Archives of Gerontology and Geriatrics*. <https://doi.org/10.1016/j.archger.2007.10.006>

A Study on the Needs for Guidelines on Part-And-Whole-Based Training for Volleyball Smash Basic Technique

Danang Wicaksono¹, Furqon Hidayatullah², Agus Kristiyanto³, Sapta Kunta Purnama⁴
 {danang_wicaksono@student.uns.ac.id¹, furqon@fkip.uns.ac.id², aguskriss@yahoo.co.id³}

Universitas Sebelas Maret Surakarta, Surakarta, Indonesia^{1,2,3,4}

Abstract. This study aims to identify coaches' needs for guidelines on training volleyball spike basic techniques, combining both part and whole training methods. Data in this descriptive study were collected using questionnaires filled out by 39 volleyball coaches in Special Region of. Data were then analyzed using quantitative descriptive method reported in percentage. Results indicated that coaches (100%) agreed that a combination of part and whole trainings was effective and capable of maximizing the quality of volleyball spike basic techniques. 40% of the respondents claimed highly necessary while to the other 60%, guidebooks to volleyball spike basic technique combining part and whole training methods were necessary. In regard to availability of instrument for assessing performance on volleyball spike technique, 63% of the coaches claimed that practical instrument for assessing spike technique performance of beginner volleyball athletes remained absent in sensor systems because the sensors used in UDM devices use laser sensors.

Keywords: Spike, Volleyball, Part Training, Whole Training

1 Introduction

Volleyball game is part of net sports in which players are obliged to hit the ball over the net to the opponent's area, making sure the opponent fails to return the ball over the net [5]. The main goal of net games is to score more points by hitting more balls/objects than the opponent does [6]. Volleyball is a relatively tough game requiring complex techniques ranging from basic to advanced levels. To play this game, players should master proper basic techniques, requiring them to follow some special tips. The patterns of techniques in volleyball are relatively sequential and repetitive. The series of volleyball cycles can be seen in the following figure:

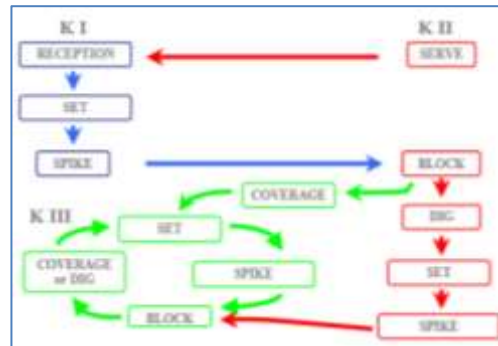

Fig. 1. The structure or cycle in volleyball game [9]

Techniques in volleyball were developed based on practices, aiming at finding solutions to problems in certain motions in most economic and useful manners [1]. Basic techniques should be taught and trained as effectively as possible due to the fact that mastery of basic techniques is the main element that influences development of techniques in more advanced level. At this stage, coaches should put forward process approach that is to develop basic techniques in volleyball games as well as possible. Coaches should thoroughly find the flaws of each technique performed by the athletes. They should also be able to provide the athletes with feedback and revisions to each mistake. Mistakes made by beginner athletes should be corrected immediately to prevent them from adopting the wrong techniques. Automation of basic techniques in volleyball game takes time; therefore, control and roles of the coaches should be central in addition to proper selection of training models. In volleyball, athletes' ability to master required kinesthetic skills constitutes an achievement. In each sport, one of fundamentals of success lies on the ability to perceive and understand movement pattern accuracy in its activity [7]. Fundamental rules in basic learning [2] includes, such as:

- The law of excellence: learn the right techniques first, avoid repeating false attempts.
- The law of sports: one will need to acquire motor skill to be fully automated. Automation is a result of exceptional repetition.

Fitts and Postner proposed three stages of motor skill acquisition that include: cognitive, fixation (associative), and autonomous stages [10]. Meanwhile, other expert, Merril (1976), identified stages in motor skill acquisition as motor mastery, refinement and stabilization or sport technique skill.

In volleyball, spike is one of techniques that incorporates considerably complex movements. This technique requires high-level movement coordination of all extremities (superior, inferior and truncus) and coordination between body movements and other objects (ball). Teaching beginner volleyball athletes basic spike techniques requires special methods. To ensure training being effective and efficient, selection of training methods to acquire new movements must be done accurately. Two methods to train movement skills include part and whole training. Whole training is one type of training in which all techniques are practiced as a whole. In part training, on the other hand, athletes practice each technique or group of techniques apart. Both methods can be combined by practicing the techniques or skills separately,

followed by combining all the parts together in a whole-training [8]. Cristina & Corcos stated that to acquire complex skills that involve a range of body parts or movements in one technique simultaneously, one can break the task to be learned down into parts [12].

Part-training method can be broken down into three parts including segmentation, fractionation, and simplification [4]. There are two keywords to break techniques down into some parts [8], including: a) The low degree of interdependence of the tasks; b) The high complexity of the tasks;

Goldstein highlighted the importance of analyzing tasks to determine whether a task can be split into coherent parts [3] as follows: a) Progressive part, in which the first two parts of the task are practiced separately before being practiced together. The third part is practiced in isolation and then added to the first two parts and so on, for example A, B, A + B, C, A + B + C; b.) Repetitive part, often known as cumulative part, in which the first part of the task is practiced separately before adding the second and the subsequent parts, for example A, A + B, A + B + C; c) Isolated part, in which some parts of the task are practiced separately before practicing the whole task, for example A, C, E, A+B+C+D+E. d) Retrogressive part, in which the last part of the task is practiced in isolation, followed by learning the last and the penultimate parts and continued until all parts are learned, for example C, B, A, A + B + C.

2 Methods

This was a descriptive study that adopted questionnaires for data collection purpose. Subjects of the study were 39 volleyball coaches in Special Region of Yogyakarta selected using incidental sampling technique. Data were then analyzed using quantitative descriptive method and reported in percentage.

3 Results and discussion

Before Survey results demonstrated coaches' awareness of the importance of spike as a predominant way to score a point in volleyball game. They understand how spike training should be adjusted to athletes' characteristics and how teaching beginner athletes differs from teaching intermediate and advanced level athletes. Training materials, in addition, should be modified to meet with athletes' levels to make sure their needs are fulfilled.

Beginner athletes are not miniature intermediate and advanced level athletes; therefore special training program should be prepared. Spike training materials for beginners should be made simpler. Coaches are aware of the fact that spike is one of the most strenuous techniques in volleyball game. This technique requires great coordination and therefore demands complex movements. Eyes, hands, and legs coordinate simultaneously to produce synchronized and efficient basic spiking techniques. A combination of timing for jumping off and hitting accuracy often adds to existing level of difficulties. This has pushed coaches to simplify materials to help beginner athletes learn spiking.

A combination of part and whole training methods can help address issues relating to spiking training process among beginners. Guidebooks to spiking that combines part and whole training methods should be made available for coaches, athletes and parents. Of all subjects, 60% coaches were informed of the availability of the books, which, however, did not specify the use of part-and-whole-training combination in spiking for beginners. On the one

hand, 33% of respondents mentioned that spiking training guidebooks remained unavailable while, at the same time, the rest 7% of respondents were completely uninformed as can be seen in the following figure:

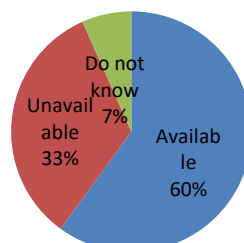

Fig. 2. Availability of guidebooks on spiking training for beginner athletes

The book content remained flawed as it failed to provide detailed information concerning what methods are accurate for teaching spiking to beginner athletes. According to the coaches, the existing books failed to explain how to teach basic spiking techniques to beginners using the simplest to the most complex methods. The books also lacked detailed examples of exercises to perform at each stage. In addition, systematic information concerning how to teach spiking techniques, either partly or wholly, remained absent.

Publication of a guidebook to basic spiking techniques for beginner athletes using a combination of part and whole trainings can help address the above-mentioned issues. Survey results have given urgency to this guidebook issue. Data suggested that 60% coaches needed the guidebook while the rest 40% really needed one.

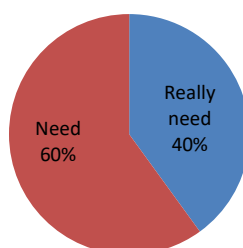

Fig. 3. The needs for a guidebook to basic spiking techniques for beginner athletes using a combination of part and whole trainings.

This training method can help to simplify spiking practices among beginner athletes. Training starts from the simplest or easiest then levels up on such gradual basis that athletes do not feel overwhelmed. When each stage is passed systematically, spiking techniques will be simpler while success rate (of the process) will be higher. Part training method provides coaches with ease in training spike basic techniques to beginner athletes. The part method leads to the whole spiking. The part spiking movements will eventually be combined as a whole via intact practice. All coaches (100%) believed that combining part and whole meth-

ods in training is highly effective and is able to maximize the quality of spiking techniques at each level (preparation, execution, landing).

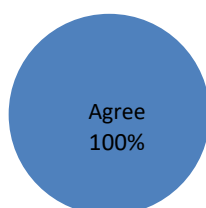

Fig. 4. Assessment resulting in the fact that part and whole training methods are effective and able to maximize quality of spiking techniques.

The whole technique is practiced to combine parts or phases in spiking, from preparation, execution, to landing, together. Coaches argued that the whole method is effective for teaching athletes who have mastered parts of the techniques (preparation, execution, landing).

Performance on practicing a technique should be evaluated constantly. Coaches have been informed of the existence of instruments to evaluate the quality of basic spiking techniques among beginner athletes. They, however, have not adopted the instruments comprehensively. Instead, they took only certain points they thought crucial for observing performance on training basic spiking techniques. Coaches, for example, observed contact made while hitting: can a player hit at his higher jump? Coaches observed the final step and arm swing while jumping off the ground. According to the survey, 63% of coaches remained clueless about instruments to assess the quality of basic spiking techniques among beginner athletes. They have not made in-depth use of existing instruments and therefore need simple and practical instruments to evaluate results of spiking training among beginner athletes.

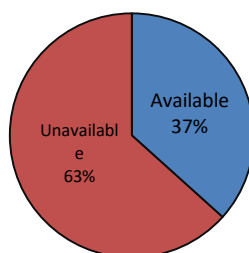

Fig. 5. Evaluation of availability of practical instrument for assessing performance on volleyball spike technique among beginners.

4 Conclusion

Teaching spiking techniques to beginner athletes requires special training method due to complexity of spike movements. A combination of part and whole trainings is one of the solu-

tions. To all coaches (100%), this combination is effective and capable of maximizing the quality of volleyball spike basic techniques in each phrase: preparation, execution, and landing. A part-and-whole combination in spiking training must be done systematically; therefore, there has been a need for a systematic guidebook among volleyball coaches. Of all subjects, 60% were informed of the availability of the training guidebooks, which, however, failed to specify the use of part and whole training combination. On the one hand, 33% subjects argued that guidebooks to spiking remained unavailable while the rest 7% remained uninformed. This has added urgency to supply of guidebooks to spiking technique training that adopts part and whole training methods specifically and systematically. Data suggested that to 40% coaches, guidebooks are necessary while to 60% of them the books are highly needed. In addition, to provide positive feedback, training method and process must be supported with instruments to assess performance. This instrument must be simple, convenient, efficient, or, in other words, practical. Data suggested that 63% volleyball coaches needed a practical instrument to assess spiking performance of beginner athletes

References

- [1] Beutelstahl Dieter. 1984. *Belajar dan Berlatih Sambil Bermain Volleyball*. Pioner Jaya. Bandung.
- [2] Bomp TO & Claro, F. 2009. *Periodization in Rugby*. Maidenhead: Meyer & Meyer Sport (UK) Ltd
- [3] Buckler R & Caple J. 2004. *The Theory and Practice of Training Rev. 5th ed.* India: Replika Press
- [4] Gopher, D. Weil, M., & Siegel, D. (1989). Practice under changing priorities: An approach to the training of complex skills. *Acta Psychologica*, 71, 147-177.
- [5] Griffin JJ. (1997). *Teaching sport concepts and skill: a tactical game approach*. Champaign, IL: Human kinetics.
- [6] Hopper T. 1998. Teaching games centred games using progressive principles of play. *Canadian Association for Health, Physical Education, Recreation and Dance Journal*, 64 (3), 4-7. <http://jonathan.mueller.faculty.noctrl.edu/toolbox/whatisit.htm#looklike>. <http://www.Bestvolleyballdrills.com/> <http://www.jssm.org>
- [7] Kenny Bonnie & Gregory, Cindy. 2006. *Volleyball step to success: sport instruction series*. USA: Human Kinetics.
- [8] Martens R 2012. *Successful coaching*. 4th ed. Human Kinetics United States.
- [9] Palao JM, Santos JA & Urena A. 2004. Effect of team level on skill performance in volleyball. *International Journal of Performance Analysis in Sport*, 4 (2), 50-60.
- [10] Schmidt AR. 1988. *Motor Control and Learning*. Second Edition. Illinois: Human Kineticks Publisher Inc.

Education and Reminder Software for Strengthening Anemia Prevention Program in Adolescent Girls

Dian Rohmatika¹, Bedjo Santoso², Leny Latifah³, Melyana Nurul Widyawati⁴
 {dianrohmatika@ymail.com¹, bedjosantoso27@gmail.com², lenylatifah1@gmail.com³}

Poltekkes Kemenkes Semarang, Semarang, Indonesia^{1,2,3,4}

Abstract. Adolescent girls, an important period for ensuring reproductive health, are tend to had anemia. Good Nutrition and consuming iron supplementation once a week which is a government program, proven effective to prevent anemia. But, the lack of knowledge and adherence of adolescent girls to consume iron supplementation hinders the success of the program. Smartphone-based education media is a compelling alternative. The study aimed to develop a smartphone-based intervention model to educate adolescent girls about anaemia and facilitating adherence of iron supplementation consumption. This was an R and D (Research and Development) study, using the 6 steps System Development Life Cycle, namely: 1. Planning, 2. Analysis, 3. Design, 4. Implementation 5. Testing, 6. Maintenance. The results education model called "DR'E-DUMIND" is developed. It contains education and reminder for taking Iron supplementation. The software requires a small storage space (7.90 MB), installed on a smartphone with the Android platform version 4.0.

Keywords: Educational model, Adolescent girls, Iron supplementation

1 Introduction

Adolescent girls are vulnerable groups of anemia, on the other hand an important group for the preparation of reproductive health. Anemia is a state of the body experiencing a decrease in the concentration of hemoglobin in adult males less than 13 g/dL and in adult women not pregnant less than 12 g/dL.[1] According to Riskesdas data year 2012, the prevalence of anemia in adolescent girls aged 10-18 is 57.1% and at the age of 19-45 is 39.5%.[2] The data of Riskesdas year 2013 Prevalence of adolescent anemia and women of childbearing age with 15 years old as 22.7% and in pregnant mothers 37.1%.[3] Prevalence of expectant mother anemia aged 15-24 years old (84.6%), 25-34 years old (33.7%), 35-44 years old (33.6%), and age 45-54 (24%).[4]

Unbalanced Nutritional intake in foods consumed daily can cause anemia in adolescent girls, because if food intake is less than many iron reserves are being uncov-

ered.[5] Anemia in adolescent girls can lead to lower learning concentration, body productivity, endurance, so it is easy to get infected.[6] If continuing to become pregnant women will contribute greatly to the pain rate of mothers and infants, miscarriage, infant birth premature, the low birth weight babies, stunting, the risk of bleeding before and during childbirth, causing death in mothers and infants.[7]

Prevention of anemia can be through a good nutritional intake and consume iron supplementation once a week which is a government program. The objectives of the government program include junior and senior high school, and women outside the school as an attempt to resolve the nutritional problem.[6] According to data of Riskesdas year 2018, adolescent girls who received an iron supplementation at school is 76.2% and in pregnant women as much as 26.8%.[4] There is still a lack of adolescent girls knowledge about the benefits of consuming nutritious food and iron supplementation into one factor affecting the compliance of iron supplementation consumption.[8], [9] Knowledge and adherence is a very important domain in the formation of one's behavior. Adolescent girls with good knowledge do not necessarily encourage the youth to be more adherence to the iron supplementation consumption, but teenagers who comply with the iron supplementation consumption are more likely to have good knowledge. Teenagers who do not obey the consumption of iron supplementation are caused by the forgetting and lack of knowledge about the disease that will arise and get worse, and the purpose of the treatment itself.[5], [10]

The recommendations of the WHO in 2011 for the prevention and countermeasures of anemia in adolescent girls are focused on promotional and preventive activities by increasing consumption of iron high food, iron supplementation.[3] The increasing number of smartphone users in the world is making this era called the digital era. Almost all walks of life interact socially, learn, and even work by utilizing the features available on smartphones. A smartphone is a multifunctional device and can perform many tasks according to everything that is programmed by its users. Smartphones are more advanced than traditional phones, and applications can be installed according to user needs.[11] Using a smartphone is one of the new approaches by optimizing appropriate technology for health services, one of which is by increasing one's compliance and being able to educate about illness and treatment.[12] Health legislation mentions healthcare personnel can utilize technology as a promotive and preventive effort. In the other hand, during this pandemic, educational facilities are needed to minimize gathering people or coming to health services. Smartphone-based educational media can be used as one alternative. From the description, a study aimed to produce a smartphone-based education model to educate the adolescent girls about anemia and the compliance of consuming iron supplementation.

2 Methods

This research uses the *Research and Development* (R & D) method. Design build model using 6 step *System Development Life Cycle* (SDLC).

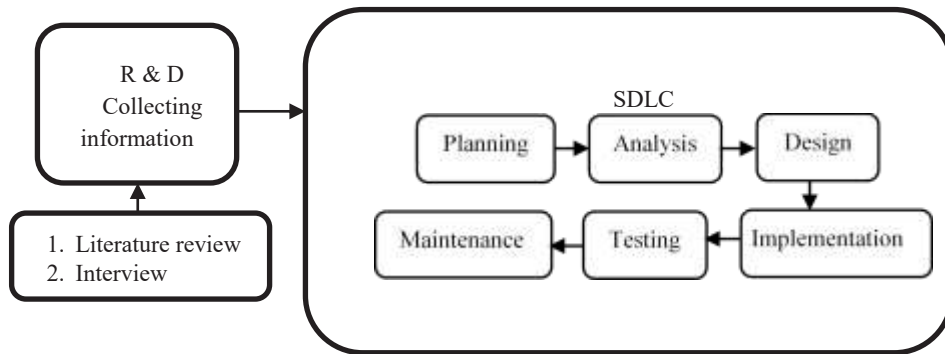

Fig. 1. Research model

The purpose of collecting information is to filter out factual information and updates related to the planning of development of educational model that will later be analyzed for problems and the needs of users and policy holders of the iron supplementation program.[13] Interviews were conducted with the Office of Health as the holder of the district level program and the Public Health Center (*Puskesmas*) as the Health Office's right-hand unit, who ran an iron supplementation program for adolescent girls in its area. While the literature study is done by analyzing journals, analyzing government policies, and other media to support the interview data.

Design build model using 6 step *System Development Life Cycle* (SDLC) namely: [14]

2.1 Planning

Summarizing the information with the study of the Library of government policies, journals, and from the results of the expert interviews with dietitian health care officers of Semarang District and health centers of Ungaran to see the suitability of models, educational materials with the needs of programs and media experts for the feasibility of models and content.

2.2 Analysis

Recognizing issues that arise to formulate concepts and determine the item of *smartphone*-based intervention model.

2.3 Design

- a. Functional need is how the system reaction to the input and what the system does in the special situation. The functional needs of the following systems:
 - 1) May display anemia information
 - 2) Can display the iron supplementation control card
 - 3) Can display iron supplementation
 - 4) Can display nutrients
 - 5) Can show alarms

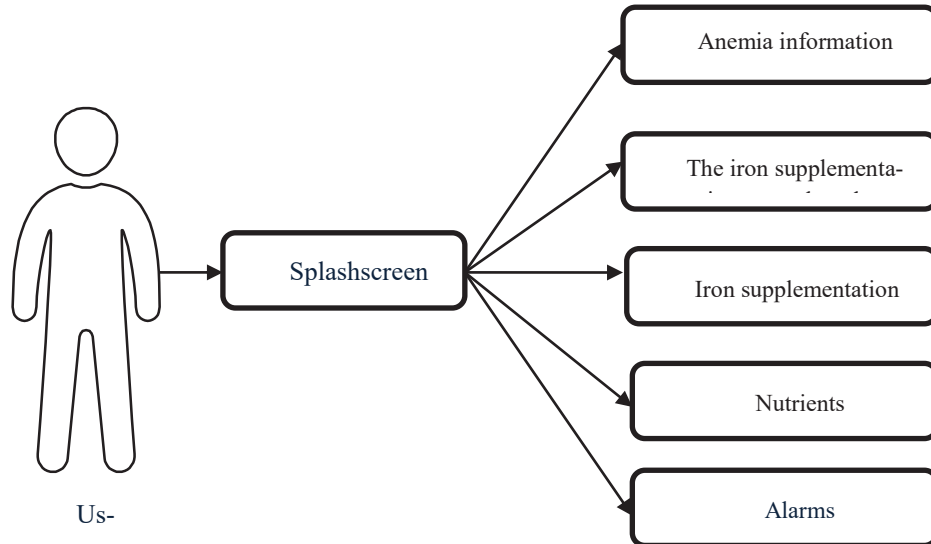

Fig. 2. Design model educational

b. Non-functional needs to support in the manufacture of educational models

1) Hardware requirement Analysis

Computers and smartphones consist of interfacing hardware and software. Software provides the instruction to the hardware to perform the tasks according to the system. Development of a smartphone-based educational model using the following hardware:

Table 1. Hardware requirements

<i>Pc /Laptop</i>	<i>Smartphone</i>
Intel Core i5-8600k Processor	Processor Qualcomm Snapdragon 810, Quad-Core 1.6 GHz
16GB RAM	2GB RAM

2) Software Requirements Analysis

Here are the minimum specifications used to build the educational model

Table 2. Software requirements

<i>Pc /Laptop</i>	<i>Smartphone</i>
WINDOWS10 64bit	Android Platform version 6.0 (Marshmallow)
Android Studio	Internal Storage 16GB
JDK version 7	
HDD 1TB	

c. User needs

It is useful to determine user-needed of the users and the user specifications of the education model.

- 1) Users of educational models of smartphone users with Android platform version 4.0 or higher
- 2) Admins as Data Manager have the capability to manage databases such as changing, reducing, adding, and deleting data.

2.4 Implementation

System designing with the construction stage, installation, testing, and transmission of the system into the product.

2.5 Testing

To know the feasibility of program needs.

2.6 Maintenance

Including system operation, repair, evaluation, and development.

3 Results



Fig. 3. The display of “DR’E-DUMIND”

Model educational android platform called "DR'E-DUMIND" contains education about anemia, iron supplementation, and alarm as a reminder to drink iron supplementation. The displayed menu contains anemia info, iron supplementation info, iron supplementation control cards, nutritional menus, and alarms. DR is an acronym for developers, E-DU is an education and information about anemia and iron supplementation, MIND is a reminder to remind the consumption of iron supplementation. *Software* needs a small storage space (7.90 MB), installed on a smartphone with

Android platform version 4.0. The validation results of the material experts mentioned the anemia and iron supplementation education materials are complete, clear, easy to understand and systematic reminder according to the needs of users and programs. The application is expected to cover many goals, not only to adolescent girls. The validation of media expert said that the software was easy to install, did not require logging in, even at low smartphone specifications, was easy to use, and without the constraints of network conditions. An alarm sounds with notification that appears on the screen, so the user doesn't lose the reminder. Future research is expected to be able to implement and evaluate models in the target group and see the user's direct response through the Technology Acceptance Model (TAM) construct.

4 Discussion

The adolescent girls' knowledge of the dangers of anemia and the benefits of iron supplementation is still low, so compliance for the iron supplementation consumption is still lacking. This has become a government constraint to reach the iron supplementation coverage as an effort to prevent and prevent anemia in adolescent girls and women childbearing age according to WHO has a target to lower the prevalence of 50% anemia in 2025.[3]

The results proved that compliance to consume iron supplementation affects the incidence of anemia in adolescent girls.[8] Technological developments that can be mastered in all fields, one of which is a health field can be utilized to increase the knowledge and compliance of adolescent girls to consume iron supplementation. Technology that can be utilized at this time one of them is a smartphone, which is a technology that is almost owned by all walks of life even in school children.[15] Smartphones can be utilized by providing educational intervention to the knowledge of anemia and iron supplementation and can improve compliance by automatically giving alarms that will sound according to the specified time.[12]

The educational model "DR'E-Dumind" is a model that provides educational intervention on anemia in adolescents, covering the understanding, symptoms, causes, effects on anemia, to the prevention. In addition, education about the iron supplementation includes understanding, composition, how to consume it, side effects and storage. The education Model "DR'E-DUMIND" also provides alarms to remind adolescent girls to consume iron supplementation on a schedule that is already set by the user. In theory Information Manipulation Mc Comack mentions that a person who receives information with a certain method and repeatedly then the message conveyed will be well received.[16]

DR is an acronym for developers, E-DU is educational and information, and MIND is a reminder to remind the consumption of iron supplementation. The Alarm will automatically beep and will bring up the on-screen iron supplementation consumption notification so that the user is not missed for the iron supplementation consumption if the smartphone is in silent mode. The Education model "DR'E-DUMIND" can be installed on smartphones with the Android platform version 4.0 and requires only a small storage space (7.90 MB). The validation results of the material experts and systematic *reminder* of the educational material according to the needs of the user and program. Validation media experts mention *software* is easy to

install even on low *smartphone* specifications, easy to use, and unimpeded network conditions.

The research is in line with the results of the Lewis et al study, intervention utilizing mobile phones potentially encourage a person to take disease precautions, and as a tool for health workers to provide intervention in the way of disease prevention.[17] "DR'E-DUMIND" educational model has a great potential to improve healthcare services in a promotional and preventive manner for several reasons; easy to install, not depend on the internet connection, the cost is relatively low, can be accessed anywhere and anytime without coming to the health service. The educational model "DR'E-DUMIND" is one of the alternatives that can be applied to educational interventions as a promotive and preventive effort of anemia because it supports to be applied in the pandemic condition which requires social distancing and not gathering crowds.

5 Conclusion

The education Model "DR ' E-DUMIND" is an educational media, information, and *reminder* about anemia and iron supplementation which is easy, practical, and systematic. Combining technology with promotive and preventive services *offline* and according to program needs. Smartphone-based education is expected that the scope of the iron supplementation can be fulfilled and support the *social distancing* government movement.

References

- [1] M. Julie T. Vieth, David R. Lane, MD, "Anemia," *Emergency Medicine Clinics of North America*, vol. 32, August 2014 2014.
- [2] K. RI, "Laporan Nasional Riset Kesehatan Dasar (RISKESDAS)," Badan Penelitian dan Pengembangan Riset Daerah, Jakarta 2013.
- [3] K. K. R. Indonesia, Pedoman Pencegahan dan Penanggulangan Anemia pada Remaja Putri dan Wanita Usia Subur (WUS). Jakarta: Direktorat Jenderal Kesehatan Masyarakat, 2016.
- [4] K. RI, "Laporan Riset Kesehatan Dasar (RISKESDAS)," Badan Penelitian dan Pengembangan Riset Daerah, Jakarta 2018.
- [5] W. Budiarni and H. W. Subagio, "Hubungan pengetahuan, sikap, dan motivasi dengan kepatuhan konsumsi tablet besi folat pada ibu hamil," 2012.
- [6] D. P. Kirana, "Hubungan Asupan Zat Gizi dan Pola Menstruasi dengan kejadian anemia pada remaja putri di SMA N 2 Semarang," 2011.
- [7] Peraturan Menteri Kesehatan Republik Indonesia Nomor 88 Tahun 2014 Tentang Standar Tablet Tambah Darah Bagi Wanita Usia Subur dan Ibu Hamil, M. k. R. Indonesia 88, 2014.
- [8] Y. Yuniarti, R. Rusmilawaty, and T. Tunggal, "Hubungan antara kepatuhan minum tablet Fe dengan kejadian anemia pada remaja putri di MA Darul Imad Kecamatan Tatah Makmur Kabupaten Banjar," *Jurnal Publikasi Kesehatan Masyarakat Indonesia*, vol. 2, 2015.
- [9] Journal article: T. Ratanasiri and R. Koju, "Effect of knowledge and perception on adherence to iron and folate supplementation during pregnancy in Kathmandu, Nepal," *J Med Assoc Thai*, vol. 97, pp. S67-S74, 2014.

- [10] R. Riza Alfian, "Aplikasi Pillbox Reminder Meningkatkan Kepatuhan Minum Obat Pasien Rawat Jalan Di Apotek Appo Farma 1 Banjarbaru," 2018.
- [11] J. L. Peck, M. Stanton, and G. E. Reynolds, "Smartphone preventive health care: Parental use of an immunization reminder system," *Journal of Pediatric Health Care*, vol. 28, pp. 35-42, 2014.
- [12] L. Dayer, S. Heldenbrand, P. Anderson, P. O. Gubbins, and B. C. Martin, "Smartphone medication adherence apps: potential benefits to patients and providers," *Journal of the American Pharmacists Association*, vol. 53, pp. 172-181, 2013.
- [13] P. D. Sugiyono, *Metode Penelitian Kuantitatif, Kualitatif, dan R&D*, 23 ed. Bandung: ALFABETA, 2016.
- [14] M. McMurtrey, "A Case Study of the Application of the Systems Development Life Cycle (SDLC) in 21st Century Health Care," *Journal of Association for Information Systems* vol. 1, 2013.
- [15] D. D. Purwanto, "Aplikasi Reminder pada Android Mobile Device," *Jurnal Sistem Informasi, Sekolah Tinggi Teknik Surabaya*, vol. 20, 2014.
- [16] L. K. B. Eldredge, C. M. Markham, R. A. Ruiters, M. E. Fernández, G. Kok, and G. S. Parcel, *Planning health promotion programs: an intervention mapping approach*: John Wiley & Sons, 2016.
- [17] H. K. Lewis Cole, Trace, "Text messaging as a tool for behavior change in disease prevention and management," *Epidemiologic reviews*, vol. 32, pp. 56-69, 2010.

The Development and Validation of Short Self-Regulation Scale (SSR) on Indonesian College Students

Dini Tresnadiani¹, Argian Rizki Taufik²
{dtresnadiani25@gmail.com¹, argianbasket92@gmail.com²}

Universitas Pendidikan Indonesia, Bandung, Indonesia^{1,2}

Abstract. The measurement of self-regulation aspects in the simpler context of Indonesian college students is still limited. This study aims to develop and extract the scale on a shorter version in the context of Indonesian college students. The analysis of short version self-regulation scale (SSRQ), begins with 17 items representing four conceptual dimensions. Meanwhile, this version analyzes 265 active college students, using exploratory factor analysis (EFA) and confirmatory factor analysis (CFA). The finding of EFA suggest the measurement model with nine items of first order factor. While the result of CFA shows that overall model of self-regulation scale is fit and consistent with the collected data based on three categories of measure which are absolute fit indices, incremental fit indices and parsimoni fit indices. This research concludes that the scale has been met validity and reliability criteria in measuring the component of self-regulation in the context of Indonesian college students.

Keywords: self-regulation scale, (EFA), (CFA), (SEM).

1 Introduction

Self-regulation is a complex systematic process [1] involving abilities of individual including thought, emotion, attention, and concentration [2]. This ability becomes a determining factor for the development, personality, and social behavior of individual decisions [3] to achieve the desired goals and standards of behavior [4]. As suggested by Manab [5], a process of an individual managing and improving their own ability to achieve goals or targets, accompanied by an evaluation process of achievement resulting in satisfaction is called self-regulation. The development of good self-regulation includes the ability to understand how to evaluate self-abilities, monitor progress, make strategic efforts, and take advantage of opportunities in the environment to help achieving their goals [6]. Thus, in order to achieve better welfare and reduce psychosomatic problems, having a high self-regulation ability is required [7].

In general, self-regulation refers to self-control and evaluation behavior. As stated by Hude [8] that self-regulation refers to control of emotion in certain situation in order to stop or manage the emerged emotion before reacting on certain events. While differences in experience, environment and ideas of individuals can influence the behavior they do. Self-regulation is influenced by several factors such as individual characteristics and personality, believed

culture and religion, motivation, confidence and triggering situation that causes the emergence of regulation process [9]. Moreover, as it results in the different implementation of abilities in the social field in terms of explaining and understanding self-regulation ability, it certainly requires a tool that is able to measure these abilities.

A lot of studies have been conducted by researchers regarding the development of a measuring instrument related to self-regulation. Reference [3] was the first developed of the Self-Regulatory Questionnaire (SRQ). Miller & Brown [10] then grouped 63 items into seven dimensions of self-regulation including (1) Receiving relevant information, (2) Evaluating and comparing information with norms, (3) triggering change, (4) Finding options, (5) Formulating a plan, (6) Implementing a plan, and (7) Assessing the effectiveness of the plan. Later, various new versions of self-regulation questionnaires were developed by several researchers based on different contexts [11, 12, 13], such as psychological well-being [13] and also academics [14].

There have been indeed many self-regulation instruments developed through conventional methods with quite large number of question items. However, items with large numbers are sometimes multidimensional since there are many similarities with other items, so that it will greatly affect the quality of the reported self-ability [15]. Also, researchers in Indonesia developing a self-regulation measuring instrument using EFA analysis and CFA using structural equation models are still limited. Rather, this method provides better and accurate result in measuring the validity and reliability of an instrument [16]. Thus, this analysis can generate a new or simpler version of self-regulation measurement model with better quality result for Indonesian students.

Therefore, this study aims to redevelop building a simplified version and examine the validity and reliability of the scale developed on [11] in Spain, consisting of 17 question items by measuring four dimensions of self-regulation which are perseverance, goal setting, decision making and learning from mistakes. This research is focused on population of students ages 19 to 24. Given the significance of having the ability of self-regulation to manage life and self-control in accordance with what will be done, so that self-report through simpler, effective and efficient measurement of self-regulation scale can provide convenience in understanding the quality of self-ability as an evaluation material to be responsible and being on the right track of their life goals.

2 Methods

2.1 Samples

The population in this study are students ages 19 to 24 from several universities in West Java. Data are collected using a cross-sectional survey design, which is collecting data one at a time [17]. Sampling based on certain considerations in accordance with research criteria or referred as purposive sampling techniques [18, 19]. The number of samples obtained for the first analysis is 120 students, while the second sample obtained is 145 students.

2.2 Instrument

The self-regulation scale was adapted from an article on self-regulation scale development [11] entitled "Factor Structure of the Self-Regulation Questionnaire (SRQ) at Spanish Universities". The analysis result stated that the Short Self-Regulation Questionnaire (SSRQ)

in Spain is consistent by measuring four dimensions of self-regulation namely perseverance, goal setting, decision making and learning from mistakes, consisting of 17 question items.

The development process of self-regulation scale is started by translating the question items into Indonesian, done by Language Institute of UPI Bandung. The short self-regulation scale is distributed by changing the entire item number starting from number 1 to 17 without randomizing or changing the order position of the items. This is conducted to simplify the process of analyzing items on new instruments.

The development of self-regulation scale instruments is measured based on perceptions about their behaviors with alternative answers to each statement giving a score of 1 (strongly disagree), 2 (disagree), 3 (doubtful), 4 (agree), 5 (strongly agree). This model is considered as a Likert scale model that is used to measure non-cognitive variables such as attitudes, opinions, and perceptions of an individual or group of people about social phenomena [18]. The five alternative answer choices aim to clarify the rejection and acceptance of the measured variable.

2.3 Statistical Analysis

The analysis process uses exploratory factor analysis (EFA) and confirmatory factor analysis (CFA) methods through structural equation models (SEM) with the help of AMOS 22 software. According to Gunarto [20], EFA analysis must meet several assumption tests, as follows:

- 1) Requirement criteria of the KMO value > 0.5 and Bartlett's Test with the significance value obtained < 0.05 . This aims to determine whether or not the correlation between variables and the sample has met the requirements, so that the data can be continued for analysis.
- 2) The requirement of MSA (Measure of Sampling Adequacy) value, as follow:
 - a) $MSA = 1$, variables can be predicted without errors by other variables.
 - b) $MSA > 0.5$, variables can still be predicted and can be further analyzed
 - c) $MSA < 0.5$, variables cannot be predicted and cannot be further analyzed or excluded from other variables.
- 3) Seeing the number of factors extracted from the total variance explained.
- 4) Seeing the rotation method through the varimax value with Kaiser Normalization. This method will show which items are included in the group of factors formed through the extraction method.

Meanwhile, according to Coskun, Oksuz, & Yilmaz [21] and Ghozali [22] argued that the analysis process of CFA must go through the following stages:

- 1) Assessing the identification of structural models by calculating the amount of covariance and variance data compared to the number of parameters to be estimated.
- 2) Evaluating the goodness of fit or suitability of the model to find out how far the model fits into the sample data based on three categories of goodness of fit, i.e.:
 - a) Absolute fit measures for overall measurement including CMIN, probability values, GFI, RMSEA.
 - b) Incremental fit measures that compare the proposed model with other models specified by researchers including TLI and CFI
 - c) Parsimony fit indices for fit measurement to be compared between models with different number of coefficients through PNFI.

- 3) Construct validity includes convergent validity, variance extracted (AVE) and construct reliability (CR).

3 Results and discussions

3.1 Findings

Based on data analysis, the findings are described in accordance with the stages of analysis used in this study, which are as follows:

3.2 Exploratory Factor Analysis (EFA)

The first stage uses exploratory factor analysis (EFA) with the help of SPSS 21 software. Respondents used are 120 students. KMO and Bartlett's Test results are presented in table 1, as follows:

Table 1. KMO and Bartlett's Test

<i>Kaiser-Meyer-Olkin Measure of Sampling Adequacy.</i>		0.822
<i>Bartlett's Test of Sphericity</i>	<i>Approx. Chi-Square</i>	900.194
	df	136
	Sig.	0.000

Note: df = Degree of Freedom

As seen in table 1 above, the KMO value is 0.822 (> 0.5) and Bartlett's Test with a significance value obtained 0.000 (< 0.05) then the assumptions on this criterion have been fulfilled. Also, looking at the value of all items with the value of MSA (Measure of Sampling Adequacy) > 0.50 , the item can still be predicted and can be analyzed further. A total of 17 items show values > 0.50 on the output anti-image correlation value, meaning all items can be predicted further and can be analyzed to the next analysis stage if selected.

Next, the total output of variance explained produces four factors extracted from the 17 items. These four factors form a group of items that have a high proportion of variants. However, only one factor is chosen that adequately explains the proposed measurement theory, namely the factor which had the largest total variance (32.4%), so it is sufficient to identify a strong construct from the data. The items selected in this factor have been grouped through the varimax rotation method and nine items have been obtained, while other items are excluded or not included in the further analysis process.

The items selected in this stage are grouped into three constructs namely goal setting, decision making and perseverance with three question items in each construct. This is done so as the value of one construct remains stable. In addition, the similarity of meaning of each item has represented or explained in each of these constructs, thus using only three items is sufficient to explain the conceptual model of self-regulation constructs [15].

The scale then distributed to the respondents according to the characteristics or criteria in the study (students aged 19-24). Table 2 below is the item of self-regulation scale as a result of selection at the EFA stage, as follows:

Table 2. Question items of self-regulation scale

Dimension	Item Number	Question Item
Goal setting	X4	I have difficulty setting goals for myself.
	X6	I have difficulty making plans to achieve my goals.
	X8	I am easily distracted from the plan
Decision making	X10	I have trouble focusing on something
	X11	I postponed decision making
	X12	When I have to decide to change something, I feel overwhelmed by the choices.
	X13	Small problems or distractions can get me off track.
Perseverance	X14	I have many plans so it is difficult for me to focus on one of them
	X15	It seems I did not learn from my mistakes

Note: X = Question Number

3.3 Confirmatory Factor Analysis (CFA)

In the next stage, nine items are analyzed using the CFA method for 145 students. The analysis shows that goodness of fit is quite good. However, the chi-square value is not significant with the p-values ≥ 0.05 . If the chi-square result is significant, it states that the model is not yet fit [22].

A good model must have a chi-square value that is not statistically significant. Therefore, the model is modified to reduce the chi-square value and increase the probability value. Modifications are made twice in the covariance between e18 and e14, e11 and e13 to correlate each other. The result of the analysis after being modified is shown in Figure 1. [1] below.

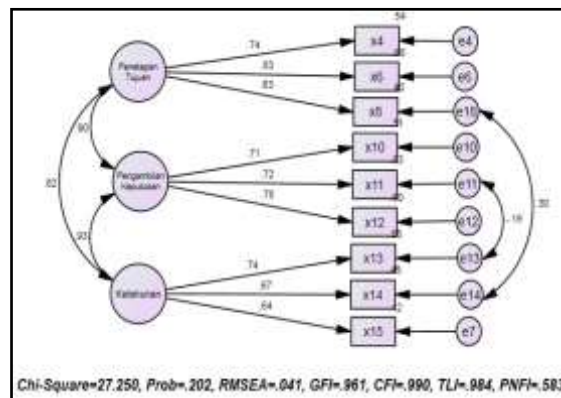

Fig. 1. Standardized estimates measurement of self-regulation model

After modification, the suitability of the model on the chi-square value and p-values results in an acceptable value based on a measure of goodness of fit. However, to be clearer, table 3 below shows the overall model suitability of the various fit model assessment criteria

recommended on [22, 20], including the absolut fit indices¹, incremental fit indices² and parsimony fit indices³, as follows:

Table 3. Result of *goodness of fit (GoF)* self-regulation model

Criteria	Limit Value	Initial Model	Final Model	Conclusion
Absolut Fit Indices				
X^2 -Chi square,	p-values	≥ 0.018	0.212	Fit
Significance probability	0.05			
CMIN/DF	≤ 2.00	1.695	1.239	Fit
GFI	> 0.90	0.940	0.961	Fit
RMSEA	≤ 0.08	0.069	0.041	Fit
Incremental Fit Indices				
CFI	> 0.90	0.969	0.990	Fit
TLI	> 0.90	0.954	0.984	Fit
Parsimony Fit Indices				
PNFI	> 0.90	0.620	0.583	Not Fit

Note: df = Degree of Freedom

On the analysis on the final measurement model, the overall assessment shows that the model is acceptable and considered to be fit according to empirical data. Further is separately evaluating related to (i) the significance of the loading indicator (ii) assessing construct reliability and (iii) variance-extracted.

Based on the CFA analysis, valid criteria is when the minimum standardized loading estimate for the initial stage of research is > 0.50 or more ideally > 0.07 [22]. Table 4 below is the output showing the value of loading factor or convergent validity in AMOS software:

Table 4. Result of convergent validity of self-regulation

Indicator			Estimate
x4	<---	Goal setting	0.738
x6	<---	Goal setting	0.826
x8	<---	Goal setting	0.634
x15	<---	Perseverance	0.644
x14	<---	Perseverance	0.671
x13	<---	Perseverance	0.744
x11	<---	Decision making	0.725
x12	<---	Decision making	0.777
x10	<---	Decision making	0.713

All items of modification stage in the CFA analysis show a convergence value of validity > 0.6 which means the indicators that make up the three constructs have a good validity value. In addition, assessing construct reliability (CR) and variance extracted (AVE) is also conducted. Reliability measures extracted from values 0 to 1, with values greater than 0.5 are ac-

¹ Absolut fit indices measures the overall models

² To compare the proposed model with other by reseachers classification

³ Parsimony fit indices to be compare between models and a different number of coefficient, include PNFI and PGFI

ceptable and $AVE \geq 0.5$ indicates a good convergence [22, 23]. Table 5 below is the result of construct reliability and AVE calculations for each construct:

Table 5. Reliability and variance extracted

Construct	$\sum\lambda$	$\sum\lambda^2$	$\sum\text{Errorvar}^*$	CR	AVE
Goal setting	2.198	1.629	1.371	0.779	0.543
Persistence	2.059	1.419	1.581	0.728	0.473
Decision making	2.215	1.638	1.362	0.783	0.546

Note: CR = Construct Reliability; AVE = variance extracted

Based on table 5 above, the reliability of the self-regulation construct shows a value > 0.70 , so it can be concluded that the reliability of each construct is considered good, while there is one construct of the variance value obtained a value of 0.475, namely the perseverance construct. This construct only measures the amount of variance that can be captured by 47.5%. Based on the loading factor values in the perseverance construct, there are two items that show values < 0.70 . This is assumed to reduce the convergent value of the construct [22].

3.4 Discussion

A research exploring the validity of the self-regulation scale was conducted by Chen & Lin [24] on students in Taiwan using confirmatory factor analysis (CFA). While, as on [13] revised a shorter scale than the scale development conducted by Brown, Miller & Lewandowski [3]. The scale was redeveloped in the context of South African students by using factor analysis and it generated seven factors of self-regulation. The scale redeveloped to a simpler and shorter version by several researchers indicates that the lighter burden of response on self-measuring instrument can affect the level of accuracy, commitment and compliance to be lower [13, 15]. Thus, this study is also conducted to extract the scale on a shorter version in the context of Indonesian students by revising the scale developed previously by Pichardo, Justicia, Fuente, & Martínez-vicente [11] on the sample of Education and Psychology students in Spain. The finding of the analysis generated 17 question items with four factors namely perseverance, goal setting, learning from mistakes and decision making.

The result of this study shows a difference between the proposed model and several short self-regulation scales developed by researchers [11, 12, 13]. As this research is conducted through two stages of analysis of student respondents in Indonesia, it generated three constructs with nine statement items. The three constructs include goal setting, perseverance, and decision making. The constructs are chosen because there are items that have content that dominates the meaning of each construct [25]. Based on an analysis of the remaining item content, one example of the contents that says "I have difficulty setting goals for myself" explains an individual who lacks commitment in achieving his or her goals. The statement has a negative meaning, but it contained another meaning that explains about how a person is motivated to achieve these goals, so it is committed to take some action. This can be called a goal setting [26].

In addition, another item says "I postpone decision making", although it has a negative meaning, the statement describes a process undertaken to determine the decisions of several alternatives from the process of discussion with the process of exchanging ideas, resulting in a wider diversity of views. [25, 27]. Other example of the items in the perseverance construct says, "Small problem or distraction can get me off track ". The item describes a measure of

how long an individual who is motivated to stay doing a task in a long time to achieve their goals [28].

Although the combination of proposed items differs with the original self-regulation scale, validity of this scale is in different cultural groups in the context of students in Indonesia, especially West Java and it covers various fields such as sports, health, education, and others. Therefore, the overall measurement of the construct validity of the self-regulation shows a fairly good value. This can be seen from the suitability index value of the model and the convergent validity that is sufficient in accordance with the estimated parameters determined as a psychological construct measurement tool. The estimates generated in this analysis do not show values that are too far so the scale can be used in further studies, supported by the result of this shorter scale which would be suitable for large epidemiological studies as it reduces the burden on respondents, without sacrificing the original strength to assess different components of the construct of self-regulation [13].

4 Conclusion

The shorter version of self-regulation scale on a sample of students in West Java, Indonesia, has become an internally consistent measurement alternative based on aspects of self-regulation relating to academic variables [11]. This version of the scale includes aspects of perseverance, goal setting and decision making. The result of model size suitability index and convergent validity indicates an acceptable value, so this scale can be used in evaluating and examining the level of self-regulation of Indonesian students. For further studies, it can be used to investigate the correlation or impact of the construct of self-regulation with various other variables.

Future research is recommended to examine the model in a larger population of students to test the stability of the model and confirm the validity and utility of the shorter version of the self-regulation scale in group of students with diverse cultures in Indonesia.

Acknowledgments

The authors would like to thank Dr. Yusuf Hidayat, M. Si and Dr. Dian Budiana, M. Pd for his contribution to the development of the SSR scale and his theoretical support during the project.

References

- [1] Jackson, T., Mackenzie, J., & Hobfoll, S.E. (2000). Communal aspects of self-regulation. In M. Boekaerts, P.R. Pintrich, & M. Zeidner (Eds.), *Handbook of self-regulation* (p. 783). San Diego: Academic Press.
- [2] Beckmann, J., & Kellmann, M. (2004). Self-regulation and recovery: Approaching an understanding of the process of recovery from stress. *Psychological Reports*, 95, 1135-1153.
- [3] Brown J. M., Miller W. R., & Lawendowski L. A. (1999). The Self-Regulation Questionnaire. In L. Vandecreek & T. L. Jackson (Eds.), *Innovations in clinical practice: A source book*. (Vol. 17., pp. 281–293). Sarasota, FL: Professional Resources Press.

- [4] Bermudez, J. (2006). Personality science, self-regulation, and health behavior. *Applied Psychology: An International Review*, 55(3), 386-396.
- [5] Manab, A. (2016). Memahami Regulasi Diri : Sebuah Tinjauan Konseptual. 19–20.
- [6] Gestsdottir, S., Bowers, E., von Eye, A., Napolitano, C. M., and Lerner, R. M. (2010). Intentional self-regulation in middle adolescence: the emerging role of lossbased selection in positive youth development. *J. Youth Adolesc.* 39, 764–782. doi: 10.1007/s10964-010-9537-2
- [7] Kruger, S & Sonono, E. (2016). Physical activity and psychosomatic-related health problems as correlates of quality of life among university students. *Journal of Psychology in Africa*, 26(4), 357–362. <https://doi.org/10.1080/14330237.2016.1185907>
- [8] Hude, M Darwis. (2006). Emosi: Penjelajahan Religio-Psikologis tentang Manusia di dalam Al-Qur'an. Jakarta: Erlangga
- [9] Rachmah, D. N. (2015). Regulasi Diri dalam Belajar pada Mahasiswa yang Memiliki Peran Banyak. 42(1), 61–77.
- [10] Miller W. R., & Brown J. M. (1991). Self-regulation as a conceptual basis for the prevention and treatment of addictive behaviors. In N. Heather, W. R. Miller, & J. Greely (Eds.), *Self-control and the addictive behaviours* (pp. 3–79). Sydney, Australia: Maxwell Macmillan.
- [11] Pichardo, C., Justicia, F., Fuente, J. De, & Martínez-vicente, J. M. (2014). Factor Structure of the Self-Regulation Questionnaire (SRQ) at Spanish Factor Structure of the Self-Regulation Questionnaire (SRQ) at Spanish Universities. (November). <https://doi.org/10.1017/sjp.2014.63>
- [12] Neal D. J., & Carey K. B. (2005). A follow-up psychometric analysis of the Self-Regulation Questionnaire. *Psychology of Addictive Behaviors*, 19, 414–422. <http://dx.doi.org/10.1037/0893-164X.19.4.414>
- [13] Potgieter J. C., & Botha K. F. H. (2014). Psychometric properties of the Short Self-Regulation Questionnaire (SSRQ) in a South African context. *Journal of Psychology in Africa*, 19, 321–328.
- [14] De la Fuente J., Sanchez F. J. P., & Roda M. D. S. (2009). Personal self-regulation and perceived maladjusted school behaviors. *Psicothema*, 21, 548–554.
- [15] Davies, K. A., Lane, A. M., Devonport, T. J., & Scott, J. A. (2014). Validity and Reliability of a Brief Emotional Intelligence Scale (BEIS-10). (1). <https://doi.org/10.1027/1614-0001/a000028>
- [16] Said, H., Badru, B. B., & Shahid. M. (2015). Confirmatory Factor Analysis (CFA) for Testing Validity and Reliability Instrument in the Study of Education Confirmatory Factor Analysis (CFA) for Testing Validity And Reliability Instrument in the Study of Education. (1).
- [17] Creswell, J. W. (2012). In Reply: BEHAVIOUR THERAPY. In *Educational Research Fourth Edition* (Vol. 112). <https://doi.org/10.1192/bjp.112.483.211-a>
- [18] Sugiyono. (2010). Metode Penelitian Pendidikan (Penelitian Kuantitatif, Kualitatif, dan R&D). Bandung: CV Alfabeta.
- [19] Fraenkel, J. R., Wallen, N. E., & Hyun, H. H. (2011). *How to Design and Evaluate Research in Education*. New York:McGraw-Hill.
- [20] Gunarto, Muji. (2018). Analisis Statistika dengan Model Persamaan Struktural. Bandung: Alfabeta.
- [21] Coskun, K., Oksuz, Y., & Yilmaz, H. B. (2017). Ten Years Emotional Intelligence Scale (TYEIS): Its Development , Validity and Ten Years Emotional Intelligence Scale (TYEIS): Its Development , Validity and Reliability. (February).
- [22] Ghozali, Imam. (2017). Model Persamaan Struktural Konsep dan Aplikasi dengan Program AMOS 24. Semarang: Badan Penerbit UNDIP.
- [23] Raines-eudy, R., & Raines-eudy, R. (2009). Using Structural Equation Modeling to Test for Differential Reliability and Validity : An Empirical Demonstration Teacher's Corner Using Structural Equation Modeling to Test for Differential Reliability and Validity : An Empirical Demonstration. 5511. <https://doi.org/10.1207/S15328007SEM0701>
- [24] Chen, Y. H., & Lin, Y. J. (2018). Validation of the short self-regulation questionnaire for Taiwanese college students (TSSRQ). *Frontiers in Psychology*, 9(3), 1–10. <https://doi.org/10.3389/fpsyg.2018.00259>
- [25] Iedliany, F., Fahmie, A., & Kusriani, E. (2018). Pengembangan dan Validasi Instrumen Pengukuran Efektivitas Tim di Usaha Mikro Kecil dan. 3(2), 177–196.

- [26] Ali, A. J., & Ngang, T. K. (2015). Penetapan Tujuan Dan Keadilan Organisasi Serta Dampaknya Terhadap Efektivitas Sekolah : Sebuah Kajian Eksplorasi. *Jurnal Manajemen Pendidikan*, 8(1), 52–66.
- [27] Bhudianto, W. (2015). Kepemimpinan dalam pengambilan keputusan. *Transformasi*, 27(1), 18–23. Retrieved from <https://ejournal.unisri.ac.id/index.php/Transformasi/article/view/910/762>
- [28] Robbins, S., dan Timothy A. J. (2008). *Perilaku Organisasi, Organizational Behaviour*. Buku Terjemahan, Jakarta: Gramedia.

The Relationship of Concentration and Accuracy Against Shooting Free Throw Results in High School Students Who Follow Basketball Extracurricular

Doni Pranata¹, Widiyanto²
 {donipranata.2019@student.uny.ac.id¹, widi@uny.ac.id²}

Yogyakarta State University, Sleman, Indonesia^{1,2}

Abstract. This research was conducted against the background of the analysis of the matches when competing basketball and aims to determine whether there is a relationship between concentration and accuracy of the results of free throw shooting on students extracurricular activities in SMA Negeri 2 Palembang. This uses the correlation method. The population used was the high school students of Palembang 2 and the sample of this study was 60 people. The results of this study are as follows the concentration and accuracy has a very weak relationship to the results of shooting freethrow basketball. The correlation coefficient value of 0.374 indicates that there is a relationship between the concentration variable and the accuracy of the free throw is at a low level. From these data it can be concluded that there is a relationship between concentration with free throw shooting results, and also between accuracy with free throw shooting results.

Keywords: accuracy, basketball, concentration, free throw

1 Introduction

Basketball is a sport that can be played by all ages and is favored by the majority community in children. Basketball is a group ball sport consisting of two teams of five people who compete with each other, collecting points, by entering the ball according to the opponent's basket. Basketball is easy to learn because of the large shape of the ball, so it cannot be played by the player reflecting or throwing the ball [1][2]. There are various aspects that can support athletes in playing basketball. According to observations that took place on the field during a basketball match. From the results held in South Sumatra, namely the DBL (Developmental Basketball League) when the men's basketball team Xaverius 1 Palembang against SMA Negeri 2 Palembang were players not reporting at the time of the match due to factors from in each of their respective players such as stress, anxiety and so on depending on the first quarter and second quarter Palembang team made SMA Negeri 2 a turning point very far from the opposing team as a result there was a lot of risk reversing and analysis when doing free shooting throws. Then, at the break time of the second quarter to the third quarter, a coach instructed to point to a point where each athlete was present with a relaxed body condition and closed his glasses for two minutes with the aim that the athlete could be better suited for this match.

After being given assistance to focus the minds of the players so they can still support the athlete, in the following quarter, this team can direct the points by attempting to shoot into the ring, even the athletes can win the match with more scores than their opponents. Shooting is a very important skill in a sports basket. Shooting is a technique that can be drilled alone. The basic skill that an athlete must practice is shooting accuracy. Many basketball games are won or lost at the freethrow line [3] This will free the opponent to continue to stick to the player tightly and is easy to fool, and then makes it easy to pass and accompany the ball well (Wissel, 2000: 43) Free throws very often win or lose in matches, so practice free throws in each practice [4]. Accuracy is one's ability to do something carefully, precisely, carefully, thoroughly and accurately. Sajoto in [5]. According to Sajoto in (Nopriadi, 2015: 310) Accuracy (accuracy) is the ability of a person to control the free movement of a target. This goal can be a distance or maybe a direct object that must be worn with one part of the body. Meanwhile, according to Sikumbang, et al., In (Nopriadi, 2015: 32) argues that accuracy is the ability of a person to control movements. As in the implementation of shooting a basketball, kicking the ball toward the goal and others.

Factors that influence concentration during a match are related to outside activities such as school / college, work on assignments and reduce the hours of rest that require increased concentration. Komarudin in [6] Concentration is a very important role in sports because if you experience difficulties, problems will arise. Concentration is very important role in sports because it will be difficult to arise (Komarudin, 2015: 142). According to Wilson, Peper; & Schmid (2006: 1) Compilation with the ability to focus attention on someone with the task being done and thus cannot be done or supported by external and internal stimuli that are not relevant. According to Setyobroto in (Komarudin, 2015: 134) explains the definition of change relating to two dimensions, namely the dimensions of width (width) and dimensions of concentration (focus).

Based on the background above in this research is to study the relationship of concentration and testing of the results of free throws on students who take basketball extracurricular activities in SMA Negeri 2 Palembang.

2 Methods

The method used in this research is quantitative with correlation design. In this research, there are 2 independent variables, namely concentration (X1) and accuracy (X2). While the dependent variable is the result of shooting a free throw basketball (Y).

The population of this research is the students of SMA Negeri 2 Palembang who take extracurricular activities. All 60 SMA Negeri 2 Palembang students. The sample technique used was Judgment sampling. According to Abdurahman, M., Muhidin, S.A., Somatri, A (2011: 143) Judgment sampling (also known as purposive sampling) is a sampling technique that is based on the characteristics set for the target population elements that are adjusted to the objectives or research problems.

Data collection techniques in this study were carried out by giving the paper concentration test grid, to measure concentration, under ring to measure accuracy test and foul shoot test to measure basketball free throw shooting. Data analysis technique used by researchers is the product moment correlation test technique with SPSS 16.0 for Windows program help.

3 Results and discussion

There is a significant relationship between concentration and accuracy of the results of free throw shooting in students who take basketball extracurricular activities in SMA Negeri 2 Palembang.

Table 1. Correlation of the value of concentration, accuracy and shooting free throw

	Correlations		
	Value of Concentration	Accuracy	Shooting Free Throw
Value of Concentration			
Pearson Correlation	1	.020	-.005
Sig. (2-tailed)		.918	.980
N	30	30	30
Accuracy Pearson			
Correlation	.020	1	.202
Sig. (2-tailed)	.918		.284
N	30	30	30
ShootingFreeThrow			
Pearson Correlation	-.005	.202	1
Sig. (2-tailed)	.980	.284	
N	30	30	60

This can be seen from the correlation significance value of the concentration value, accuracy and shooting free throw obtained correlation value between concentration and accuracy of 0.20, concentration and shooting free throw 0.05, accuracy and shooting free throw 0.202. to determine the level of correlation and relationship of a data can be seen from table 2.

Table 2. Guidelines for providing correlation coefficient interpretations

Correlation Coefficient Intervals	Relationship Level
0,00 – 0,199	Very weak
0,20 – 0,399	Weak
0,40 – 0,599	Middle
0,60 – 0,799	Strong
0,80 – 1,000	Very strong

From this table it can be seen that the degree of relationship between concentration and accuracy is weak, accuracy and free throw shooting are weak, and concentration and free throw shooting are very weak.

The correlation between the concentration and accuracy variables on the results of free throw shooting on students who take extracurricular basketball has a positive direction, meaning that the direction is the lower the level of concentration and accuracy possessed by the player, the more inappropriate the shot taken at the player when shooting free throw, vice versa. Concentration emphasizes the athlete's ability to focus his attention on the stimulus chosen by him in a predetermined period of time. to raise the definition of concentration to the surface taken from the definitions put forward by experts sourced from the book Komarudin (2015: 134). according to Slameto in (Rahmayani 2017: 7) Concentration is to focus the mind

on a particular object by putting aside things that are not related to the learning and teaching process carried out. Komarudin in [7] which states that "Concentration is very important role in sports because if disturbed then problems will arise. Especially in sports that require accuracy of throws, punches, kicks and shots on target, with the concentration of these activities will run smoothly and in accordance with the wishes. According to Satiadarma in [8] concentration is an important aspect of sports not only during matches but also during training. According to Komarudin in (Sunawa et al., 2018) Concentration is a very important role in sports because if disturbed then problems will arise. Concentration is the ability to maintain focus on activities that exist in a rapidly changing environment on thoughts about the past or future that cause unrelated cues and often make chaotic appearances in Mylsidayu in [9]. According to [10] Concentration is a condition in which a person's consciousness is focused on a particular object with a certain time, the better the concentration the longer. One way concentration is one aspect of a target that is bigger than the one on the card.

The results of the relationship in this study are very low because the average subject has a low concentration level, which results in a low free throw shooting. The lower the concentration level of the player, the more difficult for players to score when shooting free throw, and vice versa high concentration can create good shots and score a lot in free throw shooting. Accuracy is the ability to direct a motion to a target in accordance with its objectives. Accuracy is the fit between the will (desired) and the reality (results) obtained against certain goals (objectives) Suharno in (Andita, 2015: 12). Accuracy is defined as an individual's skill to direct an object precisely to the desired target, as stated by Ahmadi in [11]. According to Sajoto in (Nopriadi, 2015: 310) accuracy (accuracy) is the ability of a person to control the free movements of a target. This target can be a distance or maybe a direct object that must be worn with one part of the body. According to [12] the accuracy required while a player who can score at all stages of the game under different conditions is very important for accuracy in shooting and winning. Meanwhile, according to Sikumbang, et al., In (Nopriadi, 2015: 32) argues that accuracy is the ability of a person to control movements. As in the implementation of basketball shooting, kicking the ball toward the goal and others. According to Abdurahman et al (2011: 133) accuracy (accuracy) is how carefully the tool measures what should be measured, so accuracy speaks of the distance measured from the target. The hypothesis of the contribution of accuracy and the results of extracurricular basketball free throw shooting at SMA Negeri 2 Palembang amounted to $r = 0.202$ if it was presented to be 20.2% indicating the relationship obtained was weak.

The relationship results in this study are low because the average subject has a low level of accuracy, so it results in a low free throw shooting too. The lower the level of accuracy of the player, the more difficult players will score when shooting free throw, and vice versa high accuracy can create good shots and score a lot in free throw shooting. Shooting free throw, according to Karsono in (SMA & SLEMAN, n.d.) that shooting is the last target of every play. The ability of a team in research is always determined by the ability to play in shooting, therefore the element of shooting is a basic technique that must be learned properly and correctly and improved skills with practice. According to [13] free throw is a gift given by the referee to the player to score one number in a position directly behind the free throw line. Free throwing is usually given if the opposing player violates a prohibited area. Boot free throw is an opportunity given by a person players to score one number, not guarded, from a position behind the free throw line and inside the circle (Perbasi, 2016: 45). towards further study by providing a link between the results of the analysis achieved with the theory. According to Hall Wissel in (Sunawa et al., 2018) explains that in doing the free throw standing technique

one of them is to pay attention to views, the intended point is that the player must focus on the meaning of the goal when performing the free throw standing technique that requires high concentration. According to Price, Jayme; Gill, Diane L.; Etnier, Jennifer; Kornatz, Kurt, (2009: 719) successful free-throw requires attention skills and physical abilities; Therefore, understanding the attention demands of skills can provide guidance out the results to be achieved, 2) Thinking about events (failure), 3) Feeling depressed, 4) Physiological disorders, 5) Fatigue and 6) Poor motivation.

4 Conclusion

The low correlation results in this study are due to the low level of concentration in the players, namely where the players feel unable to understand and master their thoughts and feelings, so they are unable to focus attention at one point. Concentration is a skill that is very difficult for athletes to master, therefore concentration must be trained by the coach because if an athlete fails to control his concentration the athlete is difficult to predict to be able to focus on doing his job well, and difficult to predict to be able to win the match (Komarudin, 2015: 135). Inability experienced by athletes is influenced by the stimulus that is around the player and the stimulus that is in the player. When players are tired or tired, it will affect the subject in the game, when the research takes place, it is very obvious that the subject is not enthusiastic and looks tired because of lack of rest because after school. This is as expressed by Schmid, et al [14] that the influence of internal stimulus and external stimulus can affect one's concentration. According to [15] explain the factor of concentration disturbances from the athlete's internal (internal) there are several factors, including: 1) thinking ab

In this research, it can be concluded that there is a significant relationship between concentration and accuracy of the results of free throw shooting in students who take basketball extracurricular activities in SMA Negeri 2 Palembang. This can be seen from the correlation significance value of the concentration value, accuracy and shooting free throw obtained correlation value between concentration and accuracy of 0.20, concentration and shooting free throw 0.05, accuracy and shooting free throw 0.202. to determine the level of correlation and relationship of a data can be seen from table 3.6. from the table it can be seen that the degree of relationship between concentration and accuracy is weak, accuracy and shooting of free throw are weak, and concentration and shooting of free throw are very weak. The low correlation in this study is due to the inability experienced by athletes to be influenced by the stimulus that is around the player and the stimulus that is in the player. When players are tired or tired, it will affect the subject in the game, when the research takes place, it is very obvious that the subject is not enthusiastic and looks tired because of lack of rest because after school.

References

- [1] Susanto. *Praktik Permainan Bola Besar*. Jakarta: CV Rama Edukasitama; 2013.
- [2] Susanto O. *Praktik Permainan Bola Besar*. Jakarta Timur CV Rama Edukasitama. 2013;
- [3] Tran CM, Silverberg LM. Optimal release conditions for the free throw in men's basketball. *J Sports Sci*. 2008;26(11):1147–55.
- [4] Kosasih D. *Fundamental basketball first step to win*. Semarang: Karangturi Media; 2008.

- [5] Ridwan M. PENGARUH LATIHAN MENGGUNAKAN MEDIA TALI DAN SIMPAI TERHADAP AKURASI TEMBAKAN BEBAS (FREE THROW) PERMAINAN BOLA BASKET SISWA PUTRA EKSTRAKURIKULER SMA NEGERI 15 BANDAR LAMPUNG. 2016;
- [6] Sunawa MK, Rustiadi T, Soekardi S. The Contribution of Hand-Eye Coordination, Muscle Arm Strength, and Concentration to Standing Throw Shoot Results. *J Phys Educ Sport*. 2018;7(2):141–51.
- [7] INDRA CAHYA Y. Hubungan Tingkat Konsentrasi Siswa Terhadap Hasil Akhir Under Basket Shoot Bola Basket (Studi pada peserta ekstrakurikuler bola basket di SMAN 11 Surabaya). *J Pendidik Olahraga dan Kesehat*. 2017;5(3).
- [8] Jamaliah N, Kasmini OW. PENGARUH HYPNOTHERAPY DAN TINGKAT KECEMASAN TERHADAP KONSENTRASI ATLET PUTRI CLUB PEKERJAAN UMUM (PU) DELI SERDANG SUMATERA UTARA TAHUN 2015. *J Phys Educ Sport*. 2015;4(1).
- [9] Kuswoyo DD, Pramono H, RC AR. Kontribusi Percaya Diri, Konsentrasi dan Motivasi terhadap Kinerja Wasit Persatuan Sepak Bola Seluruh Indonesia Provinsi Sumatera Selatan. *J Phys Educ Sport*. 2017;6(3):241–7.
- [10] Meirizal U. Positive Thinking To Improve Performance Achievement Athlete. In: *Asean Sport University International Conference (AUSCIC)*. AUSCIC 2014; 2014. p. 210–5.
- [11] KRISNA SARI R. KONTRIBUSI TINGKAT KECEMASAN TERHADAP KETEPATAN PASING BAWAH PADA CABANG OLAHRAGA BOLAVOLI (Studi Pada Tim Ekstrakurikuler SMAN 1 Menganti). *J Kesehat Olahraga*. 2016;4(4).
- [12] Dominic OL, Chado MA, Gwani JA, Dikki CE. Interplay Among Physical Characteristics Play Position And Shooting Accuracy Of Elite-Female Basketballers. *Act J Phys Educ Sport Heal Recreat*. 2018;7(2):90–6.
- [13] Hardiyono B. PENGARUH METODE LATIHAN SHOOTING TERHADAP HASIL SHOOTING FREE THROW. *Altius J Ilmu Olahraga dan Kesehat*. 2017;6(2).
- [14] Anggraeni Putri S. HUBUNGAN ANTARA KONSENTRASI DENGAN KETEPATAN FREE THROW PADA PEMAIN BOLA BASKET SMA NEGERI 3 SIDOARJO PADA SAAT LATIHAN. *Character J Penelit Psikologi*. 2017;5(1).
- [15] Weinberg RS, Gould D. *Foundations of sport and exercise psychology*, 7E. Human Kinetics; 2018.

The Competitive Anxiety (Cognitive, Somatic, Affective, and Motoric) among Martial Art Athletes

Donny Wira Yudha Kusuma¹, Mugiyo Hartono², Mohammad Annas³, Harry Pramono⁴,
Endang Sri Hanani⁵, Pradesta Ayu Krismonita⁶
{donnywirayudhakusuma@mail.unnes.ac.id¹, hartonofik@mail.unnes.ac.id², syakhustini@mail.unnes.ac.id³}

Universitas Negeri Semarang, Semarang, Indonesia^{1,2,3,4,5,6}

Abstract. The comparison of anxiety profiles on martial arts remains an interesting object to be examined. The present study is to compare the competitive anxiety characteristics between martial art athletes. Survey design was used in this study, this was to determine anxiety condition of Student Sports Training and Education Center (PPLOP) in Central Java Province. A total of 59 athletes from seven various of martial art of Central Java athletes (fencing, wrestling, karate, pencak silat, taekwondo and judo) composed the sample. The instrument used was the Sport Anxiety Scale (SAS). The result reported that Judo has the highest mean on cognitive anxiety (11.20) and motoric anxiety (34.20). Thus, pencak silat has the highest mean score on affective anxiety (11.40). Boxing has lowest mean score on cognitive anxiety (9.33), somatic anxiety (17.83), and motoric anxiety (28.83). One could observe based on the results found, that athletes on each martial art are constantly distinguished.

Keywords: competitive anxiety, martial art, central java.

1 Introduction

The interaction between technical, tactical, physical and mental is a factor that influences the athletes appearance [1–3]. The study in the sports psychology show that there are personality diversity between swimmers, wrestlers, basketball athletes, baseball athletes, and footballer [4]. Other study found on soccer, wrestling, gymnastics and karate shows that the personality characteristics of the athletes are different [5]. According to Williams & Reilly [6] based on the results of the research on football there are some psychological characteristics such as high confidence, control of the level of arousal, focus on high tasks and the capacity to perform fully spirit that need to be known by young athletes. While sports psychology studies specifically on martial arts have been reviewed in previous studies [7,8], the advantages of martial training reviews [7,9], and reviews of psychological effect for mid age martial training [10]. Along with this, [11] found that karate athletes scored significantly higher on achievement, conscientiousness, visualization, intuition, goal setting, managing pressure, self-efficacy, fear of failure, flow, emotion, self-talk, self-awareness, ethics, empathy, relationship and impression management. Pencak silat athletes scored significantly higher on adaptability, stress management, power and aggressiveness. Taekwondo has highest average only on competitiveness variable.

The literature review shows that the aspects psychology have differences in each individual in performance. Grossarth-Maticcek et al [12] reported psychological factors related to success in soccer and boxing athletes. Mahoney et al, [13] illustrated The ideal profile constructed by the sport psychologists generally paralleled the skill differences encountered, although the elite athletes did not report selected amplitudes in the profile. Furthermore, Bäckmand H et al [14] found that athletes who had participated in power/combat sports and team sports were more extroverted, more satisfied with their lives than were the referents. It is concluded that former athletes differ from nonathletes in some personality characteristics and depression. Zinsser et al [15] concluded that optimism is important for martial art athletes because it will have an impact on improving fighting power, concentration, and focus on attention.

The obvious factor that really affects the ability of athletes is psychological factors. One of the aspect is anxiety. Many studies examined the impress of anxiety in sport performance [16, 17, 19]. Usually, anxiety reported when performer were not confident in dealing with stress inducing competition situation [19] and and possibly affect various types of sports [20].

Anxiety usually occurs in athletes were called competitive anxiety. Competitive anxiety is a specific negative response in personal emotion to competitive stressor (Fletcher, et al, 2009). Research in the link of competitive anxiety and performance was based on the inverted-U hypothesis. Basic opinion or hypothesis put curvilinear connectivity between performance and arousal [1,22].

There are different point of views about anxiety; the state anxiety and trait anxiety were made by Spielberger [23,24], and the second is the somatic anxiety and cognitive anxiety conveyed by Martens, et al,[27] . Trait anxiety refers to anxiety in the aspect of personality. He said when anxious, athletes experienced the physiological changes associated with high stress, including rised heart rate and blood pressure, 'butterflies' in the stomach, faster breathing and flushed face. Anxiety increases heart rate and blood pressure. Increases metabolism and increased oxygen consumption. The dimensions of competitive anxiety tend influenced by sex, type of sport and level of ability. Concerning sex, female athletes are more prone to feel more anxious compared with male athletes [1].

The comparison of competitive anxiety profiles on martial arts remains an interesting object to be examined; but must take into account the methodological view and validity. Needs to be added to the number of athletes, not just to one group of athletes but in the sub-group who need limits in the study. In this context, the present study is to compare the competitive anxiety characteristics between Martial art athletes (Karate, Pencak Silat, Taekwondo, Wrestler, Boxing, Fencing and Judo), verify similarities and differences between groups.

2 Methods

Survey design was used in this study with ex post facto research design. This was to determined anxiety condition of Student Sports Training and Education Center (PPLOP) in Central Java Province. A total of 59 athletes (women, n=32 and men, n=27) from seven various of martial art provincial athletes of Central Java (fencing, wrestling, karate, pencak silat, taekwondo and judo) composed the sample. All individuals were informed about the objectives of the research and that data would only be used for research purposes and generally analyzed, and they signed a consent form to participate in this study. Samples obtained from

athletes who are at the Central Training Center for Student Sport (PPLOP) of Central Java province.

The instrument used was the reviewed Indonesian version of the Sport Anxiety Scale (SAS) by Smith, et al, (1990). that containing 22 questions with 4 indicators; somatic (items: 1, 4, 9, 10, 12, 15, 20), cognitive (items: 3, 7, 12), motoric (items: 2, 5, 6, 13, 16, 17, 18, 19, 22), and affective (items: 8, 11, 14). The final score from 22 to 88 for all score of SAS, with 22 indicating low anxiety and 88 indicating high anxiety. For each item, athletes indicated how they uniquely felt based on 4-point Likert scale, ranging from *not at all* (1) to *very much* (4). The data was taken during Nasional Competition of PPLOP or multi events competition, and spesific competition of sports. Test conducted ± 30 minutes before the competition match begin.

For the analysis of the competitive anxiety between martial art athletes, the descriptive analysis was initially used (average and standard deviation) for the behavior of each variable to be studied. Later, after making sure the normality of data using Kolmogrov-Smirnov test. Multivariate Analysis of Variance (MANOVA), at the significance level of 0,05 was used in order to determine the differences between study groups.

3 Results and discussions

In this study, we examined comparisons were made between various martial arts sports in anxiety items (cognitive, somatic, affective and motoric) using Multivariate Analysis of Variance (MANOVA). Comparisons were made between indicators of competitive anxiety and between type of martial arts sports.

3.1 Socio-demographic characteristics

The socio-demographic sample is shown in Table 1, ie: the total number of samples of 59 athletes (female, n=32 and male, n=27) from seven (7) martial art provincial athletes of Central Java, 10 pencak silat athletes (m=4, f=6), 5 judo athletes (m=2, f=3), 10 wrestling athletes (m=7, f=3), 6 boxing (m=1, f=5), 9 karate (m=4, f=5), 12 taekwondo (m=6, f=6), and 7 fencing athletes (m=3, f=4). The mean of age for all samples were 16.2.

Table 1. General characteristics of the samples (n=59)

Characteristics	Pencak silat	Judo	Wrestling	Boxing	Karate	Taekwondo	Fencing	Total
n (Total)	10	5	10	6	9	12	7	59
n (Male)	4	2	7	1	4	6	3	27
n (Female)	6	3	3	5	5	6	4	32
Age (mean)	17.3	16.4	16.1	15.8	15.4	16.6	16	16.2

3.2 Comparison of competitive anxiety among martial art athletes

The result of comparison of groups shows in table 2., there are have differences among martial art sports on cognitive anxiety variable (sig.= 0.024 < 0.05), and no defferences reported for affective anxiety, somatic anxiety and motoric anxiety (sig.= 0.066; 0.145; 0.237 > 0.05). Judo has the highest mean on cognitive anxiety (11.20) and motoric anxiety (34.20). Thus,

pencak silat has the highest mean score on affective anxiety (11.40). Boxing has lowest mean score among other types of sports on cognitive anxiety (9.33), somatic anxiety (17.83), and motoric anxiety (28.83).

Table 2. The study of mean difference among research groups in the competitive anxiety

Variable		Pencak Silat		Judo		Wrestling		Boxing		Karate		Taekwondo		Fencing		F	Sig.
		mean	S.D	mean	S.D	mean	S.D	mean	S.D	mean	S.D	mean	S.D	mean	S.D		
Anxiety	Cognitive	10.20	1.476	11.20	1.095	9.60	3.026	9.33	2.066	10.33	2.000	9.92	0.900	9.71	2.138	0.596	0.024
	Affective	11.40	1.265	10.80	1.095	9.50	2.877	10.83	.983	10.67	1.658	10.58	1.832	9.43	2.225	1.272	0.066
	Somatic	20.00	2.981	19.40	1.949	20.10	5.043	17.83	2.137	21.33	2.345	19.58	2.392	18.29	3.946	0.981	0.145
	Motoric	31.20	4.077	34.20	1.095	30.10	8.595	28.83	3.920	32.33	4.359	30.58	4.963	32.43	3.309	0.735	0.237

Then, Karate have top mean score on somatic anxiety (21.33). fencing has lowest score on affective anxiety (9.43). While for taekwondo and wrestling are in between other martial art sports, because the all score mean is among other martial arts sports. With the result if it is sorted from top to bottom, then the sport has the highest to lowest anxiety level in a row is judo, karate, pencak silat, taekwondo, fencing, wrestling, and boxing.

There are various factors that cause athletes to appear anxiety, especially feelings of anxiety, anxiety because of fear of failure in the match, fear of injury or injury to the opponent, and fear of not being able to compete properly is a separate burden and can be a stressor that can cause anxiety if the athlete cannot overcome it [27]. In line with Drost (2014) reported that the most dominant element causing anxiety is the cognitive element, namely negative worries and thoughts that the process and outcome of a match can threaten the athlete's position. Besides stress is cumulative then the occurrence of anxiety in athletes can also be caused by factors outside individual athletes such as pressure from the audience, family environment and the coach [28].

High anxiety getting flogged will cause an athlete to fail to show his appearance well. On the field athletes are reluctant to take risks to make certain movements. Even this anxiety will lead to feelings of trauma and even depression makes it less achievement. Psychological interventions that can be used to overcome this are counseling, relaxation and stress management [29]. A good psychological condition is really needed by an athlete, because by having a good psychological condition most likely an athlete will have psychological rigidity in every competition or championship. As an illustration, an athlete can be anxious when competing with a large audience. The audience's apparent effect on an athlete is generally in the form of a decline in mental state, so that it cannot perfectly display its best performance [30,31]

Kusuma & Mulyono (2019) reported [11] that karate athletes significantly higher on achievement, conscientiousness, visualization, intuition, goal setting, managing pressure, self-efficacy, fear of failure, flow, emotion, self-talk, self-awareness, ethics, empathy, relationship and impression management. Pencak silat athletes scored significantly higher on adaptability, stress management, power and aggressiveness. Taekwondo has highest average only on competitiveness variable.

4 Conclusion

The objective of the present study was to compare competitive anxiety between martial art athletes in karate, pencak silat, taekwondo, fencing, boxing, wrestling, and judo, also presented results that contrasted with findings of studies previously performed. Then, sorted from top to bottom, the sport has the highest to lowest anxiety level in a row is judo, karate, pencak silat, taekwondo, fencing, wrestling, and boxing. However, it became clear that athletes are significantly distinguished in most psychological variables studied. One could observe based on the results found, that athletes on each martial art are constantly distinguished. This verification indicates consistence of the data collected and points to a possible generalization of differences between individuals from both groups; fact that deserves further investigations.

References

- [1] Jones G, Hanton S, Connaughton D. What is this thing called mental toughness? An investigation of elite sport performers. In: *Journal of Applied Sport Psychology*. 2002. p. 205–18.
- [2] Bompa TO, Gregory Haff H. *Periodization: Theory and Methodology of Training*. 5th ed. United States of America: Human Kinetics; 2009.
- [3] Abbott A, Button C, Pepping G, Collins D. Unnatural selection: Talent identification and development in sport. *Nonlinear Dynamics Psychol Life Sci*. 2005;9(1):61–88.
- [4] Allen MS, Greenlees I, Jones M. Personality in sport: A comprehensive review. *International Review of Sport and Exercise Psychology*. 2013.
- [5] Singer RN, Hausenblas H a, Janelle C. *Handbook of Sport Psychology*. Handbook of Sport Psychology. 2000. 13–19 p.
- [6] Williams AM, Reilly T. Talent identification and development in soccer. *J Sports Sci*. 2000;
- [7] Fuller JR. Martial arts and psychological health. *Br J Med Psychol*. 1988;
- [8] Woodward TW. A review of the effects of martial arts practice on health. *Wisconsin Medical Journal*. 2009.
- [9] Tsang TWM, Kohn M, Chow CM, Singh MF. Health benefits of Kung Fu: A systematic review. *Journal of Sports Sciences*. 2008.
- [10] Douris P, Douris C, Balder N, Lacasse M, Rand A, Tarapore F, et al. Martial Art Training and Cognitive Performance in Middle-Aged Adults. *J Hum Kinet*. 2015;
- [11] Kusuma DWY, Mulyono A. Comparison of Athletes Personality between Martial Art Sports in Central Java. *Res Anal*. 2019;05(03):2357–61.
- [12] Grossarth-Maticek R, Eysenck HJ, Rieder H, Rakic L. Psychological factors as determinants of success in football and boxing: The effects of behaviour therapy. *Special Issue: Sport and leisure: Therapeutic aspects*. 1990.
- [13] Mahoney MJ, Gabriel TJ, Perkins TS. Psychological Skills and Exceptional Athletic Performance. *Sport Psychol*. 2016;
- [14] Bäckmand H, Kaprio J, Kujala U, Sarna S. Personality and mood of former elite male athletes - A descriptive study. *Int J Sports Med*. 2001;
- [15] Zinsser N, Bunker L, Williams JM. Cognitive techniques for building confidence and enhancing performance. *Appl Sport Psychol Pers growth to peak Perform*. 2006;
- [16] Kusuma DWY, Bin W. Effect of Yoga Program on Mental Health: Competitive Anxiety in Semarang Badminton Athletes. *J Kesehat Masy*. 2017;13(1):121–30.
- [17] Ford J, Ildfonso K, Jones M, Arvinen-Barrow M. Sport-related anxiety: current insights. *Open Access J Sport Med*. 2017;
- [19] Englert C, Bertrams A. Anxiety, ego depletion, and sports performance. *J Sport Exerc Psychol*. 2012;
- [20] Arent SM, Landers DM. Arousal, anxiety, and performance: A reexamination of the inverted-U hypothesis. *Res Q Exerc Sport*. 2003;

- [21] Brooks AW. Get excited: Reappraising pre-performance anxiety as excitement. *J Exp Psychol Gen.* 2014;
- [22] Fletcher JR, Esau SP, MacIntosh BR. Economy of running: Beyond the measurement of oxygen uptake. *J Appl Physiol.* 2009;107(6):1918–22.
- [23] Jarvis M. *Sport psychology: Routledge Modular Psychology.* 2005. 146 p.
- [24] Spielberger CD. CURRENT TRENDS IN THEORY AND RESEARCH ON ANXIETY. In: *Anxiety.* 1972.
- [25] Spielberger CD. Theory and Research on Anxiety. In: *Anxiety and Behavior.* 1966.
- [27] Martens R, Burton D, Vealey RS, Bump LA, Smith DE. Development and validation of the Competitive State Anxiety Inventory-2. In: *Competitive Anxiety in Sport* (edited by R Martens, RS Vealey and D Burton). 1990.
- [28] Smith RE, Smoll FL, Schutz RW. Measurement and correlates of sport-specific cognitive and somatic trait anxiety: The sport anxiety scale. *Anxiety Res.* 1990;
- [29] Hardy L, Beattie S, Woodman T. Anxiety-induced performance catastrophes: Investigating effort required as an asymmetry factor. *Br J Psychol.* 2007;
- [30] Drost J, van der Does W, van Hemert AM, Penninx BWJH, Spinhoven P. Repetitive negative thinking as a transdiagnostic factor in depression and anxiety: A conceptual replication. *Behav Res Ther.* 2014;
- [31] Schwab Reese LM, Pittsinger R, Yang J. Effectiveness of psychological intervention following sport injury. *Journal of Sport and Health Science.* 2012.
- [32] Sanghvi T, Jimerson A, Hajejbhoy N, Zewale M, Nguyen GH uon. And young child feeding practices in different country settings. *Food Nutr Bull.* 2013;
- [33] Epting LK, Riggs KN, Knowles JD, Hanky JJ. Cheers vs. Jeers: Effects of audience feedback on individual athletic performance. *N Am J Psychol.* 2011;

How Difficult Google Classroom Is? A Case Study of Blended Learning Method in Physical Education

Dony Tirta Hendriansyah¹, Billy Castyana², Tandiyoro Rahayu³, Mohammad Arif Ali⁴,
Gustiana Mega Anggita⁵
{donytirtah@gmail.com¹, billycastyana@mail.unnes.ac.id², tandiyorahayu@mail.unnes.ac.id³}

Universitas Negeri Semarang, Semarang, Indonesia^{1, 2, 3, 4, 5}

Abstract. The aim of this study was to determine the difficulty of using Google Classroom as media of the physical education learning. This quantitative descriptive research used 4-points likert survey and interview methods with indicators of ease to access, ease to operate, suitable for users, suitable for learning, and effectiveness in learning. Research conducted on 133 high school students in Semarang showed that 93.23% stated Google Classroom helped physical education learning. However, many students still complained about the difficulties in accessing the application due to internet signal. Therefore, it is important to provide new applications that can be accessed and operated offline and online so that physical education learning with blended learning methods can be carried out in all areas even though they do not yet have good internet access.

Keywords: Blended Learning, Physical Education, Google Classroom.

1 Introduction

In a pandemic like today, the use of technology cannot be separated from human life. So many benefits can be felt as a result of the use of technology in human life that they can increase productivity quickly, precisely, and accurately [1]. However, not all use of technology has a positive impact because with easy access for everyone can also lead to negative impacts [2]. Even so, the use of technology can help in the Covid-19 pandemic era, especially in physical education learning through the Blended Learning method.

Blended Learning method which is a combination of face-to-face and online methods [3] has been widely used in universities for the past decade [4]. In another study it was mentioned that Blended Learning is a unity between traditional learning that is face to face with the written communication that exists in online learning [5]. This makes Blended Learning a flexible method [6]. The research results of Vernadakis et al (2011) also showed that students who took classes with the blended learning method showed higher scores compared to those who attend face-to-face classes only [7]. This is also in line with what was said by Gomez and Igado who stated that web-based education, especially blended learning, has the ability to strengthen the core of teaching and learning so it could make students learn better [8].

Learning with this method also has various advantages [9] including students being able to improve independent learning because all material is available online. In addition, this

method can create good communication between teachers and students, fellow students, and finally be able to control learning even if it is done outside of class hours. With online media, teachers are also made easy to conduct assessments, provide feedback, and manage test results effectively and efficiently. By using an online system, this method requires media that can accommodate teachers and students, one of which is Google Classroom.

Google Classroom is a useful media to improve learning systems because this media helps teachers organize classes and improve communication between teachers and students [10]. The system created by Google in 2016, only takes six months to make it a system that is used in the wider world of education. A study found that students prefer to learn to use Google Classroom where teachers have a more passive rather than active role [11]. This system also encourages teachers to create and collect assignments from students without the need to use paper, so it is environmentally friendly. This system even allows teachers to focus more on the development of students rather than having to struggle with the correction of assignments on paper, because this system has the ability to correct and provide grades directly [10].

There are several benefits of using Google Classroom [12], including systems that are designed in a simple way so that they are easy to use. Google Classroom is also designed automatically and integrated with other Google applications, so it can save time. Currently, it has more professional technology related to communication because this system already uses cloud-based enterprise communications tools that are often used by professional workers so that it is easy to access and can be used as a learning medium, both in learning that requires face-to-face or on learning that uses the full online system. In addition, Google Classroom is also designed to be used not only by using a laptop or notebook media, but also can be accessed via a mobile phone.

In addition to what has been said above, other research also mentioned several benefits of Google Classroom [13], such as the use of Google Classroom for streaming counseling. In addition, Google Classroom is also able to facilitate collaborative learning where teachers can upload learning materials and students can provide feedback by giving comments, and vice versa [14]. It was able to assist teachers in organizing classrooms and can communicate efficiently with students [15]. This media also can improve students' cognitive abilities by making classes into student-centred learning even in previous studies showing students feel comfortable using this media and can also be applied to other subjects, one of them is physical education.

Physical education becomes important to be associated with Blended Learning because of its role can develop abilities and shape the character of students so they are able to develop their potential [16]. It also can improve physical fitness, develop motor skills, teach to have healthy living behaviors, be sporty, and increase emotional intelligence [17]. This learning has goals that focus on increasing intellectual behavior, such as developing knowledge and understanding thinking skills [18]. This can be achieved when learners fulfill the two essentials of physical education, namely the nature of learning and the nature of physical education [16]. The nature of learning is not only about teaching and transferring knowledge from teachers to students, this nature is able to open opportunities for teachers to maximize the potential of students so that they can become independent human beings [10]. The second nature is the nature of physical education, where this nature discusses how humans can move and want to move. For humans, moving has several factors that affect, among others, the physical abilities of students, their ability to move, a feeling of security to carry out activities, perceptual abilities, and emotional intelligence [19]. These factors must be considered by teachers so that physical education goals can be achieved.

However, the learning objectives will not be achieved if the students do not have enough time to actively move so that the quality of fitness is good. This happens because of the lack of study hours given for physical education so that there needs to be a solution that is by applying the Blended Learning method with Google Classroom media. Because the application of Blended Learning can improve the quality of learning by showing changes in student outcomes, learning motivation, and interest for the better [6] [20] [21]. Unfortunately, the use of Google Classroom media in physical education learning has only been fully applied in the Covid-19 pandemic era. Not yet known the extent of the difficulty of this media. Therefore, research was conducted to determine the level of difficulty of using Google Classroom media on physical education.

2 Methods

This type of quantitative research uses descriptive research design to determine the difficulty level of students in using Google Classroom as an online media for blended learning. This research was conducted as part of research on the application of the blended learning method to physical education in high school and in the process, the teacher used Google Classroom media for the learning process. The selection of high school as a research object because the application of the blended learning method in physical education is something new, thus this learning requires an understanding of to use technology and high school students are familiar with it. The population in this study was high school in Semarang and in taking the sample, researcher used a purposive sampling technique with the criteria of a school that had implemented the K-13 curriculum, where the school have three hour credits of physical education subject.

Before carrying out data retrieval, the teachers were asked to carry out learning using the Blended Learning method with Google Classroom media for three months. Teachers gave different material, such as Futsal, Handball, Basketball, Badminton, Volleyball, Sepak Takraw, and Track and Field, involving three different classes. The material is learning material contained in the high school curriculum of the Ministry of Education and Culture. In addition, the selection of the class was because each material was not taught at the same grade so three classes were selected to study the material and the teacher was asked to apply the blended learning method to teach the material.

After all students have tried the methods, they were asked to fill in a 4-scale Likert instrument which contains four indicators, i.e. Ease to Access, Ease to Operate, Suitable for users, Suitable for learning, and Effectiveness in learning. Then the data were analyzed using percentages to see the level of difficulty in using Google Classroom media on the Blended Learning method.

3 Results and discussion

3.1 Results

Demography. In this study, there were 133 respondents who came from high school students in Semarang. The respondents have age demographics, namely respondents aged 15 years 24 people or 18.05%, age 16 years 77 people or 57.89%, and age 17 years 32 people or

24.06%. In addition, when viewed by sex, the number of male respondents was 48 people or 36.09% and female respondents were 85 people or 63.91%.

Difficulty Level. Based on the results of data analysis, it can be seen that 93.23% of respondents said Google Classroom is easy to use for physical education learning.

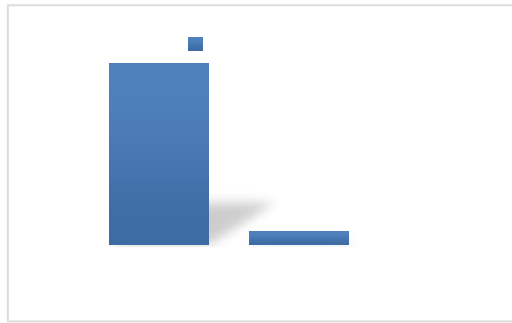

Fig. 1. Difficulty Level of Google Classroom

However, if viewe from the results of the analysis per indicator, it can be seen that only 67.67% of respondents feel that Google Classroom is suitable for users.

Table 1. Data of each indicators.

Indicators	Agree (%)	Disagree (%)
Ease to Access	92.29	7.71
Ease to Operate	94.36	5.64
Suitability for users	67.67	32.33
Suitability for learning	91.28	8.72
Effectiveness in learning	85.09	14.91

3.2 Discussion

Google Classroom is part of the online Google Apps for Education (GAFE), where this application is designed for online learning. Although users can download it for free and integrate with other Google applications, such as Gmail, Google Calendar, and Google Drive, but this application can only be used in educational institutions. This makes many teachers lazy to use it because of the lack of information provided. Though this application offers various facilities, ranging from the ease in sending information between teachers and students and between students, interactive discussions, to the distribution and collection of assignments [14].

How to Use Google Classroom. Google classroom is an application that can be downloaded via Playstore and Appstore on mobile or can be accessed via classroom.google.com. After the teacher and student download or access this system, the teacher and student can immediately log in using their email address (gmail).

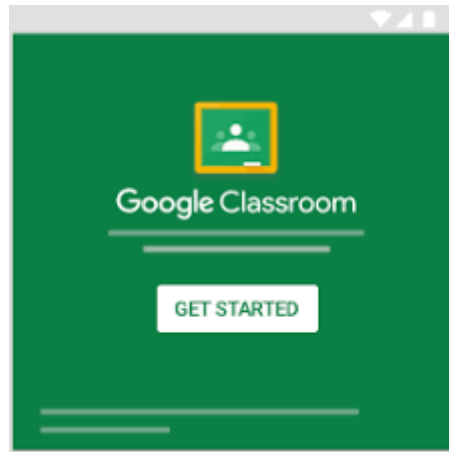

Fig. 2. Google classroom started page on mobile phone

After entering the Google Classroom application the teacher can press the button with a "+" sign. Then, two options appear, i.e. join the existing class or create a new class.

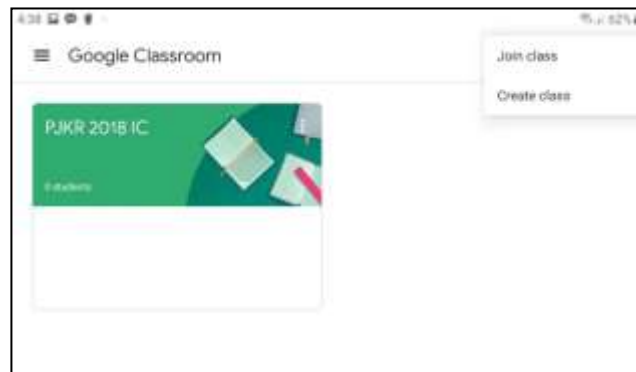

Fig. 3. Create classes in google classroom

Later, if the teacher wants to create a new class, then the teacher must fill in the class name and subjects to be taught. Whereas students can choose the option to join classes that have been available through invitations sent by the teacher or enter the class code.

Obstacles on Google Classroom. The use of Google Classroom for some users in Indonesia still has many obstacles, one of which is limited internet access. This is what causes the still high level of difficulty in using these online-based media. Most of the students who were respondents stated that when they access Google Classroom they need a large amount of data and most rely on wifi at school. This finally makes students unable to study independently by using Google Classroom. Although Indonesia is currently showing significant internet development, where there are more than 28% of the total population in Indonesia using the inter-

net²³, but this has not reached all regions. According to the report, Indonesia's Internet penetration rate is 21% with an increase of 20% over the past decade [22].

Using Google Classroom on Physical Education. In physical education classes, Google Classroom becomes the media to provide theoretical material to students. Later the teacher can upload video material that has been made by the teacher or the teacher can search for video material from YouTube then upload it to the class. The students can later see and study the video wherever and whenever before the material is practiced in class.

In order to be able to see progress and also monitor the learning process of students, teachers can discuss about the material with students through the comments column. In addition, teachers can also give assignments and theoretical tests through applications that are integrated in Google Classroom, such as Google Doc, etc.

In addition, students can also upload videos of the movements made when practicing the material in school and later the teacher can assign other students to analyze the mistakes made and how to correct techniques. This is an important part of the basic curriculum of Physical Education, where students must be able to develop their cognitive abilities through analysis. The teacher can also provide input to students through the comments column and students can improve their movements at the next meeting.

If we see from how the explanation of the implementation of Google Classroom in physical education subjects above, then we can know that this media can help teachers maximize the time of physical education subjects to make students move. Media, in turn, does not replace the function of the teacher to provide material, because teachers are required to be creative and develop various learning media so that students are not bored. This media makes learning patterns not only teacher-centered but student-centered.

4 Conclusion

Google Classroom is an application that has been around for a long time but its application is still not optimal, especially in physical education subjects. Yet through this application, teachers and students can interact with each other directly wherever and whenever. So learning theory in physical education subjects can be maximized through the Blended Learning method with Google Classroom media. Because through the Google Classroom media students can further explore their critical thinking skills and support to reduce the use of paper in the school environment.

For teachers too, this media can help to save time in conveying material in theory and make corrections to assignments given to students. This can maximize the time of physical education subjects to make students move so that they can meet the objectives of physical education.

In terms of its use which is still based on internet access, it is expected that there will be development platforms such as Google Classroom that can be used offline and online, especially for physical education. This will greatly help teachers and students, especially those in remote areas and who do not have good internet access, to be able to develop Blended Learning methods widely throughout Indonesia.

References

- [1] W. Wardiana, *Perkembangan teknologi informasi di Indonesia*. 2002.

- [2] S. Ameliola, Nugraha, and D. Hanggara, "Perkembangan media informasi dan teknologi terhadap anak dalam era globalisasi," in *Prosiding In International Conference On Indonesian Studies" Ethnicity And Globalization*, 2013.
- [3] M. Giannousi, "A Comparison of Student Knowledge between Traditional and Blended Instruction in a Physical Education in Early Childhood Course," *Turkish Online J. Distance Educ.*, vol. 15, no. 1, pp. 99–113, 2014.
- [4] P. Ginns, M. Prosser, and S. Barrie, "Students' perceptions of teaching quality in higher education: The perspective of currently enrolled students," *Stud. High. Educ.*, vol. 32, no. 5, pp. 603–615, 2007.
- [5] D. Garrison, Randy, and N. D. VAUGHAN, *Blended learning in higher education: Framework, principles, and guidelines*. John Wiley & Sons, 2008.
- [6] I. Syarif, "Pengaruh model blended learning terhadap motivasi dan prestasi belajar siswa SMK," *J. Pendidik. Vokasi*, vol. 2, no. 2, 2012.
- [7] N. Vernadakis, "The impact of blended and traditional instruction in students' performance," *Procedia Technol.*, vol. 1, pp. 439–443, 2012.
- [8] J. Gomez and M. Igado, "Blended learning: The key to success in a training company," *Int. J. Instr. Technol. Distance Learn.*, vol. 5, no. 8, pp. 33–42, 2008.
- [9] H. Husamah, "Pembelajaran bauran (Blended learning)," *Res. Rep.*, 2014.
- [10] A. Harefa, *Menjadi manusia pembelajar: Pembedayaan diri, transformasi organisasi dan masyarakat lewat proses pembelajaran: menuju Indonesia 2045*. Harian Kompas, 2000.
- [11] S. Iftakhar, "Google classroom: what works and how," *J. Educ. Soc. Sci.*, vol. 3, no. 1, pp. 12–18, 2016.
- [12] R. A. S. Al-Marroof and M. Al-Emran, "Students acceptance of Google classroom: An exploratory study using PLS-SEM approach," *Int. J. Emerg. Technol. Learn.*, vol. 13, no. 06, pp. 112–123, 2018.
- [13] M. JANZEN, "Hot Team: Google Classroom," 2014, [Online]. Available: tlt.psu.edu.
- [14] A. Keeler and L. Miller, *50 Things You Can Do with Google Classroom*. Dave Burgess Consulting, 2015.
- [15] M. Shaharane, I. Nizal, J. JAMIL, M. Rodzi, and S. Syamimi, "The application of Google Classroom as a tool for teaching and learning," *J. Telecommun. Electron. Comput. Eng.*, vol. 8, no. 10, pp. 5–8, 2016.
- [16] A. Rithaudin and I. P. T. P. Sari, "Analisis pembelajaran aspek kognitif materi pendidikan jasmani olahraga dan kesehatan sma/smk di Daerah Istimewa Yogyakarta," *J. Pendidik. Jasm. Indones.*, vol. 15, no. 1, pp. 33–40, 2019.
- [19] S. KUSAIRI, "Pengaruh blended learning terhadap penguasaan konsep dan penalaran fisika peserta didik kelas X," *J. Pendidik. Fis. Indones.*, vol. 9, no. 1, 2013.
- [20] S. B. Sjukur, "Pengaruh blended learning terhadap motivasi belajar dan hasil belajar siswa di tingkat SMK," *J. Pendidik. vokasi*, vol. 2, no. 3, 2012.
- [21] A. Abdullah and A. Manadji, *Dasar-dasar Pendidikan Jasmani*. Jakarta: Departemen Pendidikan dan Kebudayaan., 1994.
- [22] A. Baidhori, "PEMBELAJARAN PENDIDIKAN JASMANI BERBASIS BLENDED LEARNING," in *Seminar Nasional Pendidikan Olahraga*, 2017, pp. 242–250.
- [23] P. Setyosari, *Ranah Kognitif dalam Pembelajaran*. Malang: Unmal, 2013.
- [24] S. Sujarwoto and G. Tampubolon, "Spatial inequality and the Internet divide in Indonesia 2010–2012," *Telecomm. Policy*, vol. 40, no. 7, pp. 602–616, 2016.

Correlation between Teenage Nutrition Knowledges in Preventing COVID-19

Duwi Sulistiani¹, Sri Ratna Rahayu², Ari Yuniastuti³

{sulistianidwi01@gmail.com¹, sratnarahayu@mail.unnes.ac.id², ari_yuniastuti@yahoo.co.id³}

Universitas Negeri Semarang, Semarang, Indonesia^{1,2,3}

Abstract. Corona virus is now endemic in various parts of the world including Indonesia. The number of patients is increasing every day, because its spread is relatively fast and difficult to detect. As an effort to prevent COVID-19, optimal body defense is needed. One of them by consuming balanced nutritional food. The purpose of this study was to determine the relationship of nutritional knowledge in adolescents in the prevention of Covid-19. This research uses a quantitative approach with cross sectional study design. The sample size of 35 teenage respondents was selected by simple random sampling. The results of the study that there is a relationship between nutritional knowledge in adolescents in the prevention of COVID-19 with a value of $p \leq 0.05$.

Keywords: nutritional knowledge, adolescents, Covid-19 prevention

1 Introduction

Virus is now endemic in the world, including Indonesia. The number of patients is increasing every day, because its spread is relatively fast and difficult to detect. This was stated in the Journal of Autoimmunity that "Coronavirus is one of the major pathogens that primarily targets the human respiratory system. Previous outbreaks of coronaviruses (CoVs) include the severe acute respiratory syndrome (SARS) -CoV and the Middle East respiratory syndrome (MERS) -CoV which have been previously characterized as agents that are a great public health threat. In late December 2019, a cluster of patients was admitted to hospitals with an initial diagnosis of pneumonia of an unknown etiology. These patients were epidemiologically linked to a wholesale seafood and wet animal market in Wuhan, Hubei Province, China. Early reports predicted the onset of a potential Coronavirus outbreak given the estimate of a reproduction number for the 2019 [1] which was deemed to be larger greater than 1 [2]. From the journal information was obtained that the corona virus (Covid-19) is a collection of viruses that can infect the respiratory system. In many cases, this virus only causes mild respiratory infections, such as flu. However, this virus can also cause severe respiratory infections, such as lung infections (pneumonia), Middle-East Respiratory Syndrome (MERS), and Severe Acute Respiratory Syndrome (SARS) to death. This virus infection is called COVID-19 and was first discovered in the city of Wuhan, China, at the end of December 2019. This virus spread quickly and has spread to other regions in China and to several countries, including Indonesia [3].

Common signs and symptoms of Covid-19 infection include symptoms of acute respiratory disorders such as fever, coughing and shortness of breath. The average incubation period is 5-6 days with the longest incubation period of 14 days. In severe cases COVID-19 can cause pneumonia, acute respiratory syndrome, kidney failure, and even death. The clinical signs and symptoms reported in the majority of cases are fever, with some cases having difficulty breathing, and X-rays show extensive pneumonia infiltrates in both lungs [4] Covid-19 is now a serious world problem with the number of cases that is always increasing every day. Attack everyone regardless of age or gender and has been categorized as a global pandemic [5].

According to the [6], the Covid-19 problem has been experienced by almost all countries with a total of 827,419 exposed to the corona virus and 40,777 dead. COVID-19 attacks all ages and the majority affects young adults / teenagers. This is based on a journal published by Elsevier Ltd that "The age of patients was from 6 months to 94-year-old, the mortality of patients were young adults (77.4%), there was no significant difference between male and female in our study, population was generally susceptible" [7]. In Indonesia, there were 114 positive cases, bringing the total to 1,528 cases, 6 of the co-19 patients recovered, and 14 cases of death. There are 32 provinces exposed to the corona virus, one of which is Central Java Province [8]. There were 92 positive cases in Central Java Province, 92 cases treated, 77 cases treated, 8 cases recovered, 7 cases died, ODP (monitoring people) 9,434 cases and PDP (patients under surveillance) as many as 406. The prevalence of having the highest cases of covid- 10 or included in the red zone where ODP 700, PDP 54 and Positive 6, namely Semarang City.

The body's defense against viruses must be strengthened by consuming vitamins and minerals that contain vitamins A, B, C, D, E, omega 3 fatty acids, selenium, zinc, iron and copper [9] Consumption of vegetable and animal protein, reduce sugar intake, do physical activity for 30 minutes, 3-5 times a week, always get sunlight for 5-15 minutes, always happy thinking and happy thinking [8]. Viewed from a number of relevant previous studies indicate that there have been efforts to improve the balance of energy intake and nutrients in adolescents. Research by [10], [11] showed an imbalance in energy intake in adolescents due to lack of knowledge about nutritional needs and unequal distribution of nutrients for carbohydrates, proteins and fats. Also indicative of the lack of consumption of vegetables and fruit. [12], [13], studied the assessment of nutritional status using a 24-hour recall food intake survey method by a nutritionist and the Body Mass Index (BMI) anthropometric assessment.

From the explanation above mentioned one of the prevention is by consuming nutritious food and maintaining personal hygiene. Communities are encouraged to adopt a regular diet every day by fulfilling the principle of balanced nutrition consisting of carbohydrates / staple foods, animal protein, vegetable protein and vegetables, as well as fruits that can be used as healthy snacks [14] . Based on the above problem, the researcher is interested in examining Adolescent Nutrition Knowledge in Covid-19 Prevention.

2 Methods

This research uses a quantitative approach with cross sectional study design. The population in this study were all adolescents in the city of Semarang. Sampling is done by simple

random sampling technique. The dependent variable is COVID-19 prevention and the independent variable is nutritional knowledge. The sample in this study amounted to 35 teenage respondents in the city of Semarang who were selected using purposive sampling. Data collection using a questionnaire which is assisted by the Google Form program. Data analysis was performed univariately and bivariately (chi-square test).

3 Results and discussions

Nutrition knowledge is one of the factors that determine a person's food consumption. People who have good nutritional knowledge will have the ability to apply nutritional knowledge in food selection and processing so that food consumption can be expected to be guaranteed.

Table 1. Frequency of respondents knowledge of adolescent nutrition

Knowledge Category	N	%
Low	9	25,7
Good	26	74,3
Total	35	100

Table 1. Shows that as many as 9 people (25.7%) of respondents had less knowledge of adolescent nutrition, 26 people (74.3%) of respondents were well-informed about adolescent nutrition. This shows that the majority of adolescents have sufficient nutritional knowledge and below graphic of above data.

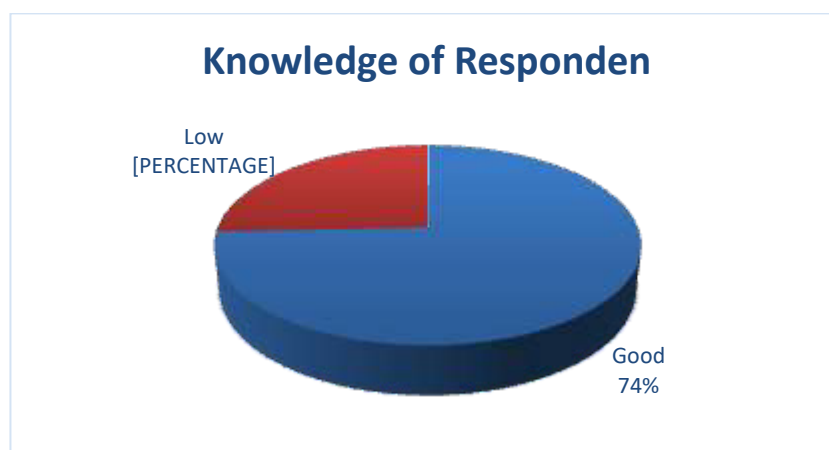

Fig. 1. Data of knowledge of responden concerning COVID-19 prevention

From above data, 26% knowledge of responden are low and 74% knowledge of responden are good. A person's level of nutritional knowledge influences attitudes and behaviors in food selection, which in turn will affect the nutritional state in question and influence the for-

mation of one's eating habits [15] Inadequate nutritional knowledge, lack of understanding of nutrition, good eating habits, and lack of understanding of the nutritional contribution of various types of food will cause problems to intelligence and productivity [16].

Adequate knowledge of adolescent nutrition is related to the availability of reading facilities and information facilities in schools, such as libraries, computer laboratories and multimedia rooms that support students to always access the latest information. Formal education is a major factor influencing one's knowledge including knowledge about nutrition and health. The higher the level of education, the easier it will be to absorb nutrition and health information so that nutrition and health knowledge will be better [17].

Table 2 : Relationship of adolescent nutrition knowledge in COVID-19 prevention

Variabel	Knowledge Category				Total		P
	Low		Good		n	%	
	n	%	N	%			
COVID Prevention							
Prevention	0		26	74,3	26	100	0,000
Not Prevention	9	25,7	0		9	100	

From table 2. it is known that of the 26 respondents with good knowledge of adolescent nutrition against those who prevent, while adolescent nutritional knowledge there are 9 respondents who are not babbling. Based on the results of statistical tests using the chi square obtained value $p = 0,000$. These results indicate that there is a relationship between adolescent nutritional knowledge in COVID-19 prevention. As per above data the grafic is below

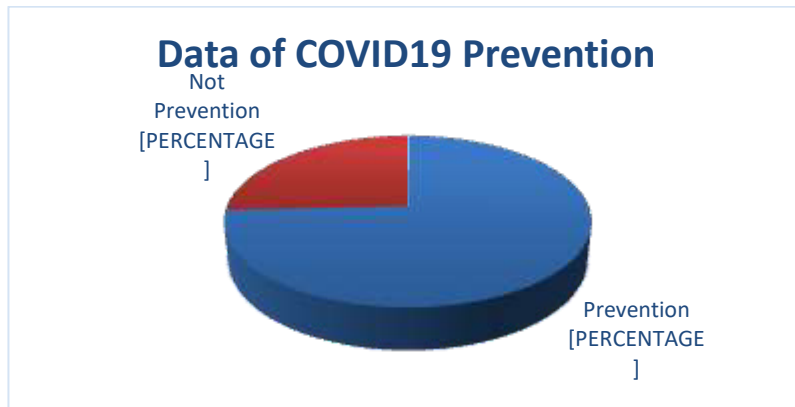

Fig. 2. Data of COVID19 prevention

From above grafic, 26% of respondent are not prevention concerning COVID19 and 74 Person are prevention concerning COVID19. Knowledge of balanced nutrition is knowledge about food and nutrients, sources of nutrients in food, safe food consumed, and how to manage food well [18]. The results showed that the majority of respondents had good nutritional knowledge.

Corona virus actually almost nothing to do with the diet of Indonesian people. [19] explains that there is no evidence that shows that food is part of the corona virus transmission route. although food is not an agent of the spread of the corona virus and is not the cause of the disease, but diet is very closely related to the resistance of the human body when attacked by the corona virus. Someone with a good diet, of course, has better endurance compared to someone who has a bad diet. This can result in the level of fatality of the corona virus attack, to the point of causing death. In someone who has a poor diet, both malnourished and who already has a congenital disease such as diabetes, has a higher risk of death. In someone who has good endurance, the corona virus may just stick to it, but the person does not experience any symptoms.

The eating patterns of some Indonesian people are not good. Basic Health Research conducted by the [20] shows that not a few Indonesian citizens are malnourished or even suffer from diabetes. This group is at risk of experiencing fatal health problems when attacked by the corona virus.

According to research [21] there is no relationship between age and knowledge about Covid-19 prevention. Age is not a limiting factor for community information sources in South Kalimantan to gain knowledge about Covid-19 prevention, because people with different age categories make it possible to have the same activity and information exposure [22].

4 Conclusions

Age is not a major factor in inhibiting community information sources in Semarang to gain knowledge about Covid-19 prevention, because people with different age categories make it possible to have the same activity and exposure to information. This study concludes that there is a relationship between adolescent nutritional knowledge in COVID-19 prevention.

Thank you to the people of Semarang City who have supported and participated in this research during the pandemic at the time the research was conducted.

References

- [1] World Health Organization (WHO), "Novel Coronavirus," World Heal. Organ., no. February, p. 2019, 2020, [Online]. Available: <https://www.who.int/indonesia/news/novel-coronavirus/qa-for-public>.
- [2] H. A. Rothan and S. N. Byrareddy, "The epidemiology and pathogenesis of coronavirus (Covid-19) outbreak," *J. Autoimmun.*, vol. 109, no. January, pp. 1–4, 2020.
- [3] H. Nielsen and K. M. Bronwen Player, "Guidance on routine immunization services during COVID-19 pandemic in the WHO European Region," 2009, [Online]. Available: <http://www.euro.who.int/pubrequest>.
- [4] Brunner and suddarth, "keperawatan Medical Bedah," Eb. EGC, pp. 0–115, 2010.
- [5] World Health Organization (WHO), "Coronavirus disease (COVID-19) in Indonesia," 2020. <https://www.who.int/indonesia>.
- [6] E. Termini et al., "No 主観的健康感を中心とした在宅高齢者における健康関連指標に関する共分散構造分析Title," vol. 21, no. 1, pp. 1–9, 2020.
- [7] S. Tian et al., "Characteristics of COVID-19 infection in Beijing," *J. Infect.*, vol. 80, no. 4, pp. 401–406, 2020, doi: 10.1016/j.jinf.2020.02.018.
- [8] KEMENKES RI, "kesiapsiagaan menghadapi kejadian COVID-19," 2020. <https://www.kemkes.go.id/>.

- [9] J. He et al., "Characteristic Electrocardiographic Manifestations in Patients With COVID-19," *Can. J. Cardiol.*, vol. 36, no. 6, p. 966.e1-966.e4, 2020, doi: 10.1016/j.cjca.2020.03.028.
- [10] L. A. A. Coutinho, C. P. M. Porto, and A. P. T. R. Pierucci, "Critical evaluation of food intake and energy balance in young modern pentathlon athletes: A cross-sectional study," *J. Int. Soc. Sports Nutr.*, vol. 13, no. 1, pp. 1–8, 2016, doi: 10.1186/s12970-016-0127-x.
- [11] B. M. Matthew J. C. Crump Nicholas P. Brosowsky, "Reproducing the Location-Based Context-Specific Proportion Congruent Effect for Frequency Unbiased Items: A Reply to Hutcheon and Spieler (2016)," 2016, [Online]. Available: <https://journals.sagepub.com/doi/abs/10.1080/17470218.2016.1206130>.
- [12] R. M. and C. R. Krystle E. Zuniga, Darcy L. Downey, "Need for and Interest in a Sports Nutrition Mobile Device Application Among Division I Collegiate Athletes," 2016, [Online]. Available: <https://journals.humankinetics.com/view/journals/ijsnem/27/1/article-p43.xml>.
- [13] S. Kim, J. H. Yang, and G. H. Park, "Eating frequency is inversely associated with BMI, waist circumference and the proportion of body fat in Korean adults when diet quality is high, but not when it is low: Analysis of the Fourth Korea National Health and Nutrition Examination Survey (KNHANES IV)," *Br. J. Nutr.*, vol. 119, no. 8, pp. 918–927, 2018, doi: 10.1017/S0007114518000557.
- [14] Y. Wang et al., "Remdesivir in adults with severe COVID-19: a randomised, double-blind, placebo-controlled, multicentre trial," *Lancet*, vol. 395, no. 10236, pp. 1569–1578, 2020, doi: 10.1016/S0140-6736(20)31022-9.
- [15] A. E. Damayanti, *Hubungan Citra Tubuh, Aktivitas Fisik, Dan Pengetahuan Gizi Seimbang Dengan Status Gizi Remaja Putri*. 2016.
- [16] M. Nova and R. Yanti, "HUBUNGAN ASUPAN ZAT GIZI MAKRO DAN PENGETAHUAN GIZI DENGAN STATUS GIZI PADA SISWA MTs.S AN-NURKOTA PADANG," *J. Kesehat. PERINTIS (Perintis's Heal. Journal)*, vol. 5, no. 2, pp. 169–175, 2018, doi: 10.33653/jkp.v5i2.145.
- [17] A. Mahasiswi, L. P. P. Graha, W. Dan, S. Inggris, and D. Semarang, "Online di : <http://ejournal-s1.undip.ac.id/index.php/jnc> mahasiswi Program Studi Sastra Inggris Undip sedangkan mahasiswi Program Studi Sastra Inggris Graha Wisata Semarang dan mahasiswi Sastra Inggris Universitas Diponegoro Semarang tidak Graha Wisata Se," vol. 2, 2013.
- [18] Prof. Dr. Soekodjo Notoatmodjo, *ilmu perilaku kesehatan*. 2014.
- [19] J. Whirworth, "Food safety issues unclear as U.K. nears Brexit; U.S. food safety regs questioned," 2020. <https://www.foodsafetynews.com/2019/03/food-safety-issues-up-in-the-air-as-u-k-approaches-brexit-u-s-food-targeted/>.
- [20] K. Riskesdas, "Hasil Utama Riset Kesehatan Dasar (RISKESDAS)," *J. Phys. A Math. Theor.*, vol. 44, no. 8, pp. 1–200, 2018, doi: 10.1088/1751-8113/44/8/085201.
- [21] A. Wulandari et al., "Hubungan Karakteristik Individu dengan Pengetahuan tentang Pencegahan Coronavirus Disease 2019 pada Masyarakat di Kalimantan Selatan," *J. Kesehat. Masy. Indones.*, vol. 15, no. 1, p. 42, 2020, doi: 10.26714/jkmi.15.1.2020.42-46.
- [22] V. Nurmala, I., Rahman, F., Nugroho, A., Erlyani, N., Anhar, *Promosi Kesehatan*. 2018.

Perception Survey, Mental Health and Social Media Exposure in Adolescents during The COVID-19 Pandemic

Efa Nugroho¹, Alfiana Ainun Nisa², Arumia Prasya Atikassyifa³
 {efa.nugroho@mail.unnes.ac.id¹, alfiana_ainun@mail.unnes.ac.id²,
 prasya.arumiia@students.unnes.ac.id³}

Universitas Negeri Semarang, Semarang, Indonesia^{1,2,3}

Abstract. In the event of an outbreak, the emergency will depress the community, which can affect the health conditions of the community. The COVID-19 pandemic has a profound effect on all aspects of society, including mental health and physical health. The risk of decreased physical and mental health can attack vulnerable groups such as the elderly, adolescents, and children. The author explores perceptions, and social media exposure during the COVID-19 pandemic. Research data will be used to develop strategies to reduce the psychological impact that may arise during a pandemic. The purpose of this study was to survey adolescents to better understand the impact of social exposure on perception during the COVID-19 pandemic. The survey was conducted on adolescents aged 10-24 years. A total of 1357 adolescents participated in this survey. The survey method was carried out online. Teenagers fill out survey forms online with certain applications. -

Keywords: Perception, Social Media Exposure, Adolescents, Covid-19

1 Introduction

COVID-19 caused panic around the world since the end of 2019. Initially, the disease was named temporarily as the 2019 novel coronavirus (2019-nCoV), then WHO announced a new name on February 11, 2020 namely Coronavirus Disease (COVID-19) caused by the virus Severe Acute Respiratory Syndrome Coronavirus-2 (SARS-CoV-2) [1]. In March 2020 WHO announced COVID-19 as a pandemic [2]. Hundreds of thousands of people are infected, even thousands more have died. This virus was first discovered in Wuhan, China and has infected as many as tens of thousands of people. The source of the host is thought to come from animals, especially bats. This virus can be transmitted from human to human. Symptoms that are usually seen include fever, coughing and difficulty breathing.

The Indonesian government issued a state of disaster emergency on 29 February 2020 related to the COVID-19 pandemic [3]. One of the steps taken by the government to prevent the transmission of this virus is by staying at home and implementing social distancing. This

step was taken to break the chain of transmission of COVID-19 by keeping a safe distance between people at least 1 meter, and not making direct contact with others, avoiding crowds and mass gatherings. [4]

The distribution of COVID-19 cases on 30 June 2020 in Indonesia was 56,385 which was confirmed positive, 24,806 were recovered and 2,876 died [5]. Cases in Central Java were found as many as 4,025 positive cases of the Corona virus, 1,820 of whom were treated (45.22 percent), 1,878 recovered (46.66 percent), and 327 died (8.12 percent). [6] Central Java is recorded as one of the five provinces with the highest number of COVID-19 cases in Indonesia, besides East Java, Sulawesi, DKI Jakarta and South Kalimantan. [5]. At present, Central Java is entering COVID-19 emergency status.

Humans as social creatures need communication to exchange information. The development of globalization has an impact on the development of Information and Communication Technology (ICT). One form of progress from ICT is social media [7]. Social media has become part of the modern lifestyle for various activities. Social media has a very important role in radically changing the lifestyle of people communicating and interacting [8]. Social media in the form of social networks and blogs make it easier for everyone to connect. Social media is a digital platform that provides information sharing / exchange facilities, user-generated content (can be ideas, images, videos, and audio-videos), and collaboration between people through a network [9]. In addition, social media has the potential to revolutionize organizational behavior. [10]. During the time of silence at home, many people who use devices to connect with the outside world. Some applications that are often used are social media. This phenomenon triggers researchers to conduct a survey of the impact of social media exposure on perception and mental health in adolescents.

2 Methods

Location of the research conducted was in Central Java. The population in this study were adolescents aged 10-24 years who were male and female, the method used in this study was a survey. Where this survey was conducted online in adolescents in the age range of 10-24 years. A total of 1357 adolescents participated in this survey. The survey method was carried out online. Teenagers fill out survey forms online with certain applications. To obtain the validity and reliability of the data the credibility, dependability, transferability and confirmability assessments are carried out, so that the findings can be trusted and have the accuracy of the data produced. This will be used to measure the level of perception and social media exposure of adolescents during the COVID-19 pandemic. The data used in this study are qualitative data. The type of research conducted is descriptive analysis, which provides education and understanding to the reader, and the type of data used in this study is secondary data.

3 Results and discussion

3.1 Adolescent Characteristics

According to the Population and Family Planning Agency (BKKBN) the age range of teenagers is 10-24 years and not yet married. The total number of adolescents who filled the

survey was 1357 adolescents. The number of early adolescents aged 10-14 years is 83 children. The number of middle adolescents aged 15-18 years is 494 children. The number of late teens aged 19-24 years was 778 children. the sexes of adolescents are grouped in 407 male and 950 girls.

Table 1. Adolescent characteristics

Age	
10-14 years	85
15-18 years	494
19-24 years	778
Gender	
Male	407
Girls	950
Education	
Not completed	23
Graduated from Elementary school	68
Graduated from Middleschool	254
Graduated from Hightschool	970
Graduated	42
Job	
Not working yet	14
Teacher	10
Student	1318
Private	15
Homebase	
Countryside	948
Urban	409

Characteristic of adolescents according to age can influence the formation of adolescent perceptions. This statement is consistent with the theory of Robbins and Judge that the variables of gender, age, level of education, and social status affect perception. [11] Turban, King, Lee, Liang, and Turban define a dependent digital generation as a representation of the young generation who are growing up in the world of broadband connections, continually connecting with information technology, and being uncomfortable when they do not have access to the internet. [12]

A total of 970 teenagers graduated high school/equivalent. There are 1258 teenagers who are students. The main activity of teenagers is going to school or college. During the pandemic, schools were closed, so teenagers had to go to school and study from home. In rural areas than urban youth. This condition is caused because many adolescents who go to school or study in urban areas must return to their homes during the pandemic. The number of adolescents who are aged 10-24 years in rural areas is 948 children, while the number of adolescents in urban areas is 409 children. The number of teenagers in rural areas is almost double that of urban teenagers.

Health conditions of adolescents must remain awake and must remain in prime condition during the pandemic mas. Mental health will make life satisfaction closely related to happiness where happy people will have a high immune system so they can ward off the outbreak of the virus [13]. A total of 661 adolescents are in good health, and only 51 adolescents feel in poor health. When associated with the Covid-19 pandemic, it is better for humans to think and interpret the positive side of the presence of the plague. then humans will be in a state of calm and alert adalam facing this plague. Besides that humans will also be better prepared and stronger in the face of other traumatic events in the future [14]

Next thing become an important concept in maintaining mental health is communication / interaction between all members family. Using communication and interaction as amechanism defenseto go through difficult times during the COVID-19 pandemic. There are 793 teenagers who agree that before Covid 19 communication / interaction between all family members was in good condition. In fact, there are as many as 736 adolescents stating that communication/interaction between all family members remained incondition good at the time of the Covid pandemic 19.

3.2 Perception

There are 442 teenagers who agree that their health will be damaged if exposed to the corona virus. SARS-CoV-2 transmission from symptomatic patients occurs through droplets that come out when coughing or sneezing [15]. Clinical manifestations of COVID-19 patients have a broad spectrum, ranging from asymptomatic, mild symptoms, pneumonia, severe pneumonia, ARDS, sepsis, to septic shock.. How large the proportion of asymptomatic infections is unknown [16]. The course of the disease begins with an incubation period of about 3-14 days (median 5 days). Some cases show the course of the disease in patients with severe COVID- 19, even more severe than the flu. There are 497 teenagers who agree that COVID-19 is heavier than the flu.

Some of the other risk factors set forth by the Centers for Disease Control and Prevention (CDC) iscontact close, including living with a COVID-19 patient and a history of travel to the affected area. Being in one environment but not in close contact (within a 2 meter radius) is considered a low risk. [17] Medical personnel are one of the populations at high risk of contracting. Hospitals are prioritized for the management of COVID-19 and illnesses with emergencies that must be dealt with immediately. There are 433 adolescents who do not agree if they have another disease, they not willgo to the hospital because of the risk of getting a new corona virus in the hospital. This illustrates that teenagers perceive that it is still safe if they go to the hospital, regardless of the risk of contracting other diseases.

Table 2. Perception

My health will be damaged if exposed to coronavirus	
Agree	442
Disagree	142
Don't know	33
Neutral	437
Very Agree	186
Very Disagree	117
Coronavirus is worse than the flu	
Agree	497
Disagree	66
Don't know	16

Neutral	343
Very Agree	328
Very Disagree	107
Won't go to the hospital because of the risk of getting coronavirus in the hospital	
Agree	229
Disagree	433
Don't know	44
Neutral	406
Very Agree	78
Very Disagree	167
Coronavirus caused serious damage to the surrounding community	
Agree	473
Disagree	100
Don't know	36
Neutral	408
Very Agree	224
Very Disagree	116
The risk of corona virus will spread widely in Central Java	
Agree	205
Disagree	261
Don't know	124
Neutral	476
Very Agree	73
Very Disagree	218
I can protect myself from the corona virus	
Agree	480
Disagree	62
Don't know	39
Neutral	431
Very Agree	245
Very Disagree	100
I can protect myself from the corona virus better than anyone else	
Agree	353
Disagree	105
Don't know	69
Neutral	598
Very Agree	156
Very Disagree	76

A total of 473 teenagers agree that COVID -19 will causing serious damage to the community around them, both in terms of social and economic.Total 476 adolescents declared neutral that COVID 19 would be widespread in Central Java. When compared with the results of the research a little different, especially related to the COVID incident in Central Java.cases Positive confirmed patientare increasing in Central Java.

A total of 480 teens perceive that they can protect themselves from COVID-19. This is because many teenagers who know several ways of prevention that they can do. Even as many as 446 adolescents believe that they can protect themselves from the corona virus better than anyone else. WHO recommendations in dealing with the COVID-19 outbreak are basic protection, which consists of washing hands regularly with alcohol or soap and water, keeping a distance from someone who has symptoms of coughing or sneezing, conducting ethic cough-

ing or sneezing, and seeking treatment when having complaints that are according to the suspect category.

Recommended distance to maintain is one meter [18]. Soap can lift and break down compounds hydrophobic such as fat or oil. [19] In addition to using water and soap, ethanol 62-71% can reduce viral infectivity. [20] Avoid touching the face especially the face, nose or mouth with the surface of the hand. When the hands are contaminated with a virus, touching the face can be an entry portal. Finally, be sure to use one-time tissue when sneezing or coughing to avoid spreading droplets [21]

3.3 Mental Health

Table 3. Mental Health

I feel cheerful and uplifting	
1-3 days	69
4-6 days	76
7-9 days	239
10-13 days	182
Everyday	764
Never	27
I feel calm and relaxed	
1-3 days	51
4-6 days	72
7-9 days	208
10-13 days	153
Everyday	834
Never	39
I feel active and excited	
1-3 days	75
4-6 days	83
7-9 days	248
10-13 days	213
Everyday	701
Never	37
I wake up feeling refreshed	
1-3 days	64
4-6 days	63
7-9 days	219
10-13 days	167
Everyday	791
Never	53
My daily life is full of interesting thing	
1-3 days	76
4-6 days	90
7-9 days	222
10-13 days	172

Everyday	734
Never	63
Feeling nervous, anxiety, or anxious	
1-3 days	605
4-6 days	203
7-9 days	155
10-13 days	105
Never	289
Can't stop or control worries	
1-3 days	584
4-6 days	190
7-9 days	133
10-13 days	64
Never	386
Feeling difficulty relaxing	
1-3 days	519
4-6 days	193
7-9 days	164
10-13 days	86
Never	395
Get very nervous	
1-3 days	555
4-6 days	137
7-9 days	99
10-13 days	37
Never	529
Gets irritated easily	
1-3 days	503
4-6 days	226
7-9 days	222
10-13 days	122
Never	284
Feeling scared as if something bad is about to happen	
1-3 days	575
4-6 days	186
7-9 days	167
10-13 days	98
Never	331

For the past 2 weeks, some teens feel that they are in a good and pleasant mental state every day. 764 adolescents felt cheerful and uplifting, 834 adolescents felt calm and relaxed, 701 felt active and excited, 791 awoke feeling refreshed, and 734 adolescents felt their daily life was full of interesting things.

There are several psychiatric problems that adolescents experience during the pandemic. but the average teenager can overcome problems that arise due to psychiatric disorders for 1-3 days. There are 605 teenagers feel nervous, anxiety, or anxious for only 1-3 days. 584 adolescents can stop or control worries, 519 adolescents who have difficulty relaxing only for 1-3 days. 555 teens get very nervous, 503 teens get irritated easily, 575 Feeling scared as if something bad is about to happen. this data shows that adolescent mental health is in a stable condition for the past 2 weeks. teens don't need a long time to experience mental health disorders, and they tend to be more able to solve them.

3.4 Social Media Exposure

A total of 1191 teenagers access whatsapp, 1072 teenagers access Instagram and several other social media. Survey results indicate that teenagers very often accessing social media, there are as many as 446 adolescents who say that. This provides information that the average social media usage activity is almost equivalent to 8 hours of employee work. If access to social media is used for positive things, then productivity can be increased in all respects. The positive impact of using social media is teenagers get entertainment, get information, and can strengthen social relationships with others. In addition to the positive effects felt by adolescents, negative impacts also arise, for example the exposure of adolescents about HOAX news about COVID19 which can cause anxiety and misperceptions occur in adolescents.

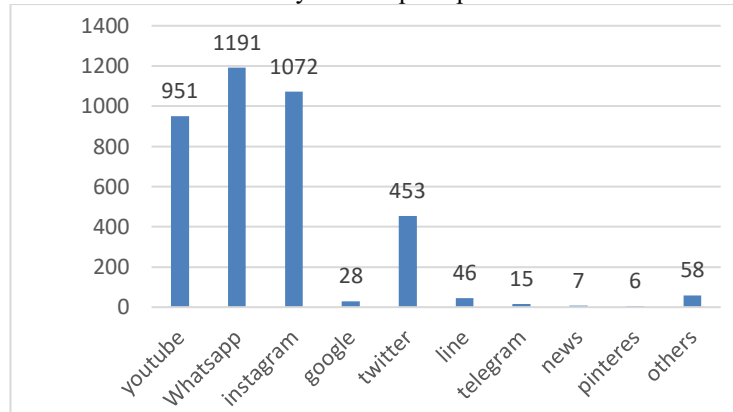

Fig. 1 Social media

Table 4. Social media exposure

In one day, how often do you Access social media (Before the Pandemic COVID-19)	
Very often	191
Often	517
Sometimes	404
Once in a while	206
Never	39
In one day, how often do you access social media (After the Pandemic COVID-19)	
Very often	446
Often	410
Sometimes	276
Once in a while	191
Never	34

“Table 4 (Continued)”

In one day, how often do you access information about COVID-19 on social media	
Very often	128
Often	388
Sometimes	491
Once in a while	284
Never	66
In one day, how often did you share information about COVID-19	
Very often	40
Often	174
Sometimes	483
Once in a while	425
Never	235

Social media exposure to adolescents can be seen in the table. Before the COVID-19 pandemic in one day 517 adolescents often accessed social media, even after the COVID-19 pandemic there were 446 adolescents whose frequency of accessing social media more often in one day.

Based on the table there are 128 teenagers who very often access information about COVID 19 on social media. This is interesting because only a few teenagers use social media to find information about COVID 19. There are 66 teenagers who have never even used social media to access information about COVID19. It is undeniable that teenagers need entertainment in the form of information about entertainment, culinary, and other entertainment topics besides COVID19 topics. There are as many as 40 teenagers who very often share information about COVID 19 after getting information from social media. But there are 235 teenagers who never share information about COVID after getting information from social media. Further research needs to be done whether the information conveyed on social media can be justified. Because a lot of HOAX news circulating on social media about the COVID19 topic.

4 Conclusion

During the pandemic many teenagers access social media. Some even have frequent frequencies in accessing social media. There are 128 teenagers who access information about COVID 19 and 40 of them spread information about COVID 19 that they get. Exposure to social media influences adolescents' perceptions of COVID 19. Adolescents assume that they can protect themselves from COVID 19 by taking basic preventative measures, where these steps are widely promoted through social media. The benefits of using social media in shaping adolescent perceptions include promoting preventive measures, selling items that can be used as personal protective equipment, studying adolescent perceptions by listening to their conversations on social media and providing support services to adolescents to answer questions about COVID19. The implication of this research for adolescents is to wisely use social media. Be aware of the positive and impacts negative of social media and wise in responding to misleading information about COVID 19.

Acknowledgement

This study received grants from DIPA PNB Faculty of Sport Science Universitas Negeri Semarang year 2020/2021.

References

- [1] World Health Organization. Naming the coronavirus disease (COVID-19) and the virus that causes it [Internet]. Geneva: World Health Organization; 2020 [cited 2020 March 29].
- [2] CNN Indonesia.(2020 Maret 12). WHO Umumkan Virus Corona Sebagai PAndemi. CNN Indonesia.
- [3] Koesmawardhani, N. W. (2020, Maret 17). Pemerintah Tetapkan Masa Darurat Bencana Corona hingga 29 Mei 2020. Detiknews.
- [4] CNN Indonesia. (2020, Maret 14). Mengenal Social Distancing sebagai Cara Mencegah Corona. CNN Indonesia.
- [5] Gugus Tugas Percepatan Penanganan Covid 19. Sebaran kasus COVID 19 di Indonesia. Covid19.
- [6] Pemerintah Provinsi Jawa Tengah. Sebaran Kasus Covid-19 di Jawa Tengah. Corona Jateng Prov.
- [7] Ayun, P. (2015). Fenomena Remaja Menggunakan Media Sosial dalam Membentuk Identitas. *Jurnal Channel*, Vol 3, 1-16.
- [8] Siddiqui, S., & Singh, T. (2016). Social media its impact with positive and negative aspects. *International Journal of Computer Applications Technology and Research*,5(2), 71-75.
- [9] Elefant, C. (2011). The “power” of social media: Legal issues and best practices for utilities engaging social media. *Energy Law Journal*,32(1), 1–56.
- [10] McFarland, L. A. & Ployhart, R. E.. (2015). Social media: A contextual framework to guide research and practice. *Journal of Applied Psychology*, 100(6), 1653–1677.
- [11] Robbins, & Stephen, P. J. (2008). *Essentials of The Organizational Behavior*. In D. Angelica, *Perilaku Organisasi Buku 1 Edisi 12*. Jakarta: Salemba Empat
- [12] Turban, E., King, D., Lee, J. K., Liang, TP., & Turban, D. C. (2015). *Electronic Commerce: A Managerial and Social Networks Perspective* (8th ed). Switzerland: Springer International Publishing.
- [13] Machado, L., Tavares, H, et all. (2015). Happiness and Health in Psychiatry: What are Their Implications. *Journal Clinical Psychiatry* vol.42 no.4
- [14] Center for Substance Abuse Treatment (US). *Trauma-Informed Care in Behavioral Health Services*. Rockville (MD): Substance Abuse and Mental Health Services Administration (US); 2014. (Treatment Improvement Protocol (TIP) Series, No. 57.) Chapter 3, Understanding the Impact of Trauma.
- [15] Han Y, Yang H. The transmission and diagnosis of 2019 novel coronavirus infection disease (COVID-19): A Chinese perspective. *J Med Virol*. 2020;
- [16] Bai Y, Yao L, Wei T, Tian F, Jin D-Y, Chen L, et al. Presumed Asymptomatic Carrier Transmission of COVID-19. *JAMA*. 2020; published online February 21. DOI: 10.1001/jama.2020.2565
- [17] Prevention CfDca. Interim US Guidance for Risk Assessment and Public Health Management of Persons with Potential Coronavirus Disease 2019 (COVID-19) Exposures: Geographic Risk and Contacts of Laboratory-confirmed Cases [Internet]. 2020
- [18] World Health Organization. Global surveillance for COVID-19 disease caused by human infection with the 2019 novel coronavirus. Geneva: World Health Organization; 2020
- [19] Kampf, Gunter.2017. Efficacy of Ethanol Against Viruses in hand disinfection. *Journal of Hospital Infection*
- [20] Jane Lee Jia Jing, Thong Pei Yi, et.all. 2020. Hand Sanitizer: A Review on Formulation Aspects, Adverse Effect, and Regulations. *International Journal of Environmental Research and Public Health* 17(9): 3326 Published online 2020 May 11.
- [21] Van Doremalen N, Bushmaker T, Morris DH, Holbrook MG, Gamble A, Williamson BN, et al. Aerosol and Surface Stability of SARS-CoV-2 as Compared with SARS-CoV-1. *N Engl J Med*. 2020;

Early Detection of Toxic Profenofos Pesticide Exposure in Farmers using Simple Chemicals

Eram Tunggul Pawenang¹, Hartono², Isna Qadrijati³, Pranoto⁴
 {eramtepe@mail.unnes.ac.id¹, hartonofkuns@yahoo.co.uk², isnaqadrijati@staff.uns.ac.id³}

Universitas Negeri Semarang, Semarang, Indonesia¹
 Universitas Sebelas Maret Surakarta, Surakarta, Indonesia^{2,3,4}

Abstract. One type of pesticide used by chilli farmers is profenofos. Therefore, to protect the health of farmers, we need to find materials that can be used as a basis for detection of pesticide poisoning. The research purposes to find materials that can be used early detection exposure of profenofos poisoning. This research with Qualitative and Quantitative methods. Qualitative test results Rhodamin 6 G shows a change in color from red to pink when reacting with profenophos. The quantitative test results obtained Rhodamin 6 G shows the value of $R= 0.891$ and the significance level is 0.007. These results indicate a strong relationship between profenophos and Rhodamin 6 G. Suggestions from this research to design an advanced early detection device so that it can be applied in the field

Keywords: early detection, profenofos, rhodamin 6 G

1 Introduction

Pestisida is a poisonous substance but is needed by farmers to protect plants from attack pests and weeds [1][2]. Climate change is currently contributing to the increase in the use of pesticides. One of the most widely used groups of pesticides is orghanopospat which has an environmentally friendly nature and is less sensitive in killing non-target organisms [3]. The number of pesticides registered in Indonesia in 2006 was 1,557 and increased in 2010 to 2,628 pesticides with 65% being organophosphate [4]. One type of organophosphate insecticide that is widely used by farmers by vegetable and chilli farmers is Profenofos [5].

Exposure to pesticides organophospat can cause major health problems in spraying farmers are both me and chronic. Acute health disorders can vaporize disorders of skin sensitivity, skin and eye irritation. While chronic disorders can include neurological disorders, tremors, prostate cancer, pancreas, uterine cancer [6] [7] [8]. Organophosphate insecticide acts as a competitive inhibitor that can inhibit the activity of the cholinesterase enzymes that accumulate in the central and peripheral nervous system. Acetylcholine (AChE) is sensitive to organophosphate or carbamate pesticides and used as a biomarker for pesticide exposure [9]. The use of AChE can detect exposure to poisoning in the chronic phase while for precautionary measures it should be able to detect exposure to poisoning before entering the body [10].

Therefore there needs to be an effort to find materials that can be used to detect profenophos exposure that exceeds the threshold when used by farmers in the field. One of the studies conducted to detect exposure to pesticides before entering the body was carried out [11]. The study used SPCE — chondosan Conductometry-based Conductometry Biosensors showed results that optimum biosensor performance was obtained at 25 μ L OPH, pH 8.5, with sensitivity to diazinon, malation, chlorpyrifos and profenofos. The use of biosensors requires high costs, so we need another alternative to detect exposure to pesticide poisoning using simple chemicals.

Chemicals that can be used include Methylene Blue, Rhodamin B and Rhodamin 6 G. The material can be used as an alternative because of its ability to detect various fields of application. Rhodamin 6G is a chemically stable organic dye, often used as a tracker to allow it to find the direction of transport and the flow rate of water. Research conducted by [12] to detect malathion and dimethoate pesticides showed that when both pesticides were added Cerium (IV) sulfate 6 rhodamine dye and chromotrope obtained detection limits of pesticide concentrations of 0.1-3.6 μ g / ml for chromotrope and 0.2-4.2 μ g / ml rhodamine 6G.

Methylene blue itself has been applied as an indicator of oxygen gas leaking. The results of the study of [13] showed that the manufacture of oxygen indicators with methylene blue as an ingredient is effective because it has a high sensitivity to oxygen. This indicator has a long shelf life, is irreversible, does not require expensive costs, and can be applied properly as in the form of sachets.

Rhodamin B is a coloring agent that is often found misusing it for food, especially snacks. Rhodamin B, which is a coloring agent in the form of green or reddish purple crystalline powder, has no odor, and is easily dissolved in a bright red color solution fluorinated as a textile or clothing coloring agent. Rhodamin B has a bright pink color. Rhodamin B color is easily identified in a sample process using a reagent kit [14].

Based on the description above, the purpose of this study is to determine the potential of Methylene Blue, Rhodamin B and Rhodamin 6 G in detecting profenophos.

2 Methods

2.1 Preparation for making methylen blue solution, rhodamin B, rhodamin 6 G, profenofos

A solution of Methylene Blue, Rhodamin B and Rhodamin 6 G 5 ppm was made with how to weigh each 1 gram of material is then dissolved into 1 liter of Aquades, equivalent to 1000 ppm. Each solution was diluted by taking 5 ml of the solution and diluted to a volume of 1 liter to obtain a solution of Methylene Blue, Rhodamin B and Rhodamin 6 G 5 ppm.

Profenofos 5 ppm solution is made with how to take 2 ml of the technical profenofos solution 500,000 ppm and then diluted with aquadest to 1 lt, equivalent to 1000 ppm. the next step is to take 5 ml of 1000 ppm then diluted to a volume of 1 liter so that a 5 ppm profenofos.

Qualitative test

The solution of Methylene Blue, Rhodamin 6 G and Rhodamin B were taken 10 ml each, then the color changes were observed visually before adding a solution of profenofos or after adding profenofos and repeated 9 times.

Quantitative test

This test is done by varying each concentration of profenofos by taking the 1000 ppm profenofos solution as much as 2.5 mL, 5 mL, 7.5 mL, 10 mL, 12.5 mL and dissolved with 1000 mL measuring flask to the boundary mark of the flask. Profenofos which have been made variations mixed with variations of these dyes each with a concentration of 5 ppm as much as 10 ml. The concentration variations were measured by the UV-Vis Instrument.

2.2 Data analysis

- 1) Qualitative test was observed by the five senses to see the color change
- 2) Quantitative test was carried out by anova test and linear regression

3 Results and discussions

3.1 Qualitative test

Test observations of chemical variations on the ability to react with profenofos

Table 1. Effect of variations in chemicals to react with profenofos

Pigment	Profenofos's test									Information
	1	2	3	4	5	6	7	8	9	
Methylene Blue	-	-	-	-	-	-	-	-	-	Does not change color
Rhodamin B	-	-	-	-	-	-	-	-	-	Does not change color
Rhodamin 6 G	+	+	+	+	+	+	+	+	+	Change color

Table 1 shows that the results of tests of 3 chemicals, when reacted with profenofos, only Rhodamine 6 G gave a color change reaction. Similarly, when repeated 9 times the results remain the same, only Rhodamine 6 G which gives a change from red to pink.

The result show that the material of Methylen Blue when reacted with profenofos has not changed before and after. These results are due to the absence of energy interactions between profenophos and methylen blue so that the color change between the two substances is not visible [15] Rhodamin B also show the same results as methylen blue there is no change in color both before and after reacting with profenophos.

Results of Rhodamin 6 G before and after the added profenofos shown the color changes from red to pink. These results are in accordance with research by [13]. showing the results that when pesticides were added Cerium (IV) sulfate 6 rhodamine coloring and obtained changes that were initially red to pink. But Rhodamine 6 G to react with Profenofos does not need Cerium (IV) Sulfate to change color. This can provide benefits because it will be more easily applied in the field without preparing other ingredients so that Rodhamine 6 G reacts with Profenofos

Qualitative test is done with the five senses namely the eyes. Then it can be possible that small color changes (faint) are not clearly visible. To ensure it all, then the 3 materials were continued to the quantitative test to see the color density changes that occur using a UV Vis spectrophotometer.

3.2 Quantitative test

Test the effect of profenofos density on the concentration level when mixed with methylen blue

Table 2. Anova test results from the density of profenofos concentration with methylen blue

Profenofos concentration	The mean	SD	95% CI	<i>p</i> value
2.5 ppm	0.24	0.02944	0.1932 - 0.2868	0.064
5 ppm	0.25	0.01414	0.2275 - 0.2725	
7.5 ppm	0.26	0.01826	0.2309 - 0.2891	
10 ppm	0.28	0.01826	0,2509 - 0,3091	
12.5 ppm	0.24	0.01633	0.2140 - 0.2660	

Based on Table 2 shows the highest average density value at a concentration of 10 ppm at 0.28 and the lowest density at a concentration of 2.5 ppm and 12.5 ppm each at 0.24 ppm. Statistical results show the value of 0.064 with alpha 0.005 so that it can be concluded that there is no difference in density in various concentrations of profenofos reacted with Methyline Blue. These results are due to Methylen Blue and Profenofos not reacting chemically.

The parameter that is the benchmark is variation in the concentration of profenofos whatever the absorbance is relatively constant when mixed with Rhodamin B. relatively constant absorbance only from methylene blue. Absorbance is a measure of the large number of compounds that absorb Uv-Vis light [16]. This result strengthens the skinative test which gives the result that Methyline Blue does not provide a color change reaction so it cannot be used as an indicator material for detection of profenophosal pestisda poisoning.

Test the effect of profenofos concentration on density level when profenofos mixed with rhodamine B

Table 3. Anova test results from the density of profenofos concentration with rhodamine B

Profenofos concentration	The mean	SD	95% CI	<i>p</i> value
2.5 ppm	0.32	0.00816	0.3070 - 0.3330	0.547
5 ppm	0.33	0.00816	0.3170 - 0.3430	
7.5 ppm	0.32	0.00816	0.3070 - 0.3330	
10 ppm	0.30	0.02944	0.2532 - 0.3468	
12.5 ppm	0.30	0.05888	0.2063 - 0.3937	

Based on Table 3 shows that the highest average density value at a concentration of 5 ppm is 0.33 and the lowest is at a concentration of 10 ppm and 12.5 ppm, respectively 0.30 ppm. Statistical results show the value of 0.547 with alpha 0.005 so it can be concluded that there is no difference in density between the various concentrations of profenofos reacted with Rhodamin B.

This result strengthens the qualitative test which gives the result that Rhodamine B does not provide a color change reaction so that it cannot be used as an indicator material for detection of profenophosal pestisida poisoning.

Test the effect of profenofos concentration on concentration level when profenofos was mixed with rhodamine 6 G

Table 4. Anova test results from the density of profenofos concentration were reacted with rhodamine 6 G

Profenofos concentration	The mean	SD	95% CI	<i>p</i> value
2.5 ppm	0.25	0.02449	0.2110	0.007
5 ppm	0.28	0.04243	0.2125	
7.5 ppm	0.30	0.04082	0.2350	
10 ppm	0.35	0.04082	0.2850	
12.5 ppm	0.375	0.06455	0.2723	

Based on Table 4 shows the highest average density value at a concentration of 12.5 ppm of 0.375 and the lowest concentration at a concentration of 2.5 ppm of 0.25 ppm. Statistical results show the *p* value 0.007 with alpha 0.005 so it can be concluded that there is a difference in concentrations between the various concentrations of profenophos reacted with Methylene Blue. This result strengthens the qualitative test that Rhodamine G provides a color change reaction from red to pink when reacted with Profenofos. Based on the two tests, Rhodamine 6G can be used as an indicator material for detection of profenofos pestisida poisoning.

Furthermore, to ascertain the shape of the density relationship between the various concentrations of profenophos and Rhodamine 6 G, a multiple linear regression test was used and the results as in Chart 1 below.

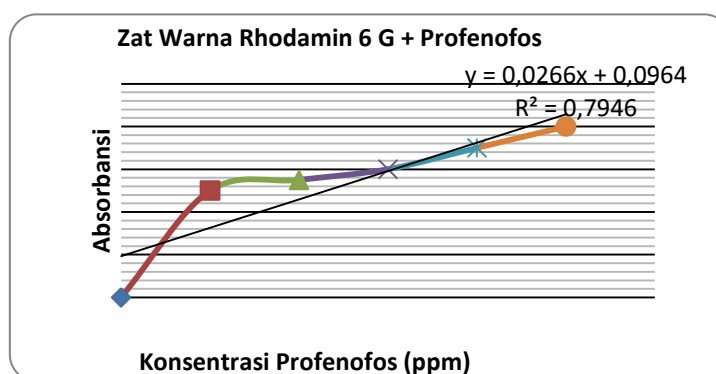

Fig. 1. Effect of Variation of Profenophos Concentration on density when Mixed Rhodamin 6 G

Chart 1 shows the density relationship between the various concentrations of profenophos and Rhodamine 6 G in the direction it shows a linear form. Due to the number of

repetitions that have not been so many then the line display does not look smooth. The results of the chart show that the greater the density of Profenofos, the higher the color density of Rhodamin 6 G. R Square (R²) gives a result of 0.7946 and R = 0.891, this means that the model is very strong for the occurrence of color changes when profenophos is reacted with Rhodamine 6 G. The linear regression in chart 1 is influenced by the concentration and absorbance. Linear regression measurements satisfy the law of Lambert Beer where absorbance is directly proportional to concentration.

The stronger linearity (R), the more valid the test is measured by the Uv-Vis Spectrophotometer [17]. The regression results of this study are not much different from the studies of cimetidine linearity obtained in the concentration range of 3-11 ppm. with the correlation coefficient on the Uv-Vis spectrophotometry method shows the results of the linear regression equation $y = 0.04928x + 0.20908$ with a value of $r = 0.99996$ [18].

The strength of the relationship model is needed to be able to make early detection of profenophosal poisoning exposure levels in the form of normal, moderate and dangerous. The current study is still a preliminary study because there is a need to follow up to make media or tools that are used as Rhodamine 6 G material when used in agriculture. This is because the 6 G Rhodamine used is liquid so it spills easily. It also needs to be continued with the use of Rhodamine 6 G which takes into account environmental factors in the field such as the temperature of the wind speed so that when reacting with Profenofos can run optimally.

4 Conclusion

Qualitative, quantitative and statistical test results show that chemicals that can be used as an indicator of early detection of Profenofos pesticide exposure are Rhodamine 6 G. The qualitative test results are shown by changing Rhodamine 6 G from red to pink when in contact with profenophos, quantitative test results there is a difference in density (Absorbance) of the concentration of Profenofos reacted with Rhodamine B and has an R value of 0.891 p value 0.007. Because Rhodamine 6 G is in liquid form, an early detection device needs to be designed that can be used as a material when applied in the field.

References

- [1] WHO. Sound Management of Pesticides And Diagnosis And Treatment Of Pesticide Poisoning. 2006.
- [2] Permentan, Minister of Agriculture Regulation No. 07 / Permentan / SR.140 / 2007 concerning Pesticide Registration Procedures and Procedures. 2007.
- [3] Koleva, NG, Schneider, UA, The impact of climate change on the external costs of pesticide applications in US agriculture. 2009. International Journal of Agricultural Sustainability, 7 (3), 203-216.
- [4] Pohan, N. Pesticides and their Pollution. 2004. University of Northern Sumatra.
- [5] Griffin, Jill. Customer Loyalty: 1996. How to Earn It, How to Keep It, New York: Simon and Chuster, Inc..
- [6] Alavanja, MCR, Hoppin, JA, Kamel, F. Health Effects of Chronic Pesticide Exposure:2004. Cancer and Neurotoxicity. Annual Review of Public Health, 25, 155-197.
- [7] Arcury, TA, Quandt, SA. Pesticides at work and at home: exposure of migrant farmworkers. 2003.. Journal of Medical Science, 362 (9400), 20-21.
- [8] Rich Deborah, . Are pests the Problem or Pesticides. 2006. Biology Journal, 28 (1): 6-7.

- [9] Abhishek Srivastava. Post-stroke depression: Prevalence and relationship with disability in chronic stroke survivors, 2010. India
- [10] Lionetto, MG, Caricato, R., Calisi, A., Giordano, ME, & Schettino, T. Acetylcholinesterase as a Biomarker in Environmental and Occupational Medicine: New Insights and Future Perspectives. 2013. *BioMed Research International*, vol. 2013, issue 1, no. 8 <https://doi.org/10.1155/2013/321213>
- [11] NK Isvani, A. Mulyasuryani, S. Prasetyawan, 2015, Performance of Screened Carbon Electrode Condensometry (Screen Printed Carbon Electrode) SPCE — Chitosan for Detection of Diazinon, Malation, Chloririphos and Profenofos, 2015. *Journal of Chemical Research and Development, Chemical Journal of VALENCY*, vol 2015 , issue 1 (2), pp. 83-90. E-ISSN: 2548-3013, [dx.doi.org/10.15408/jkv.v0i0.3156](https://doi.org/10.15408/jkv.v0i0.3156).
- [12] Ayman A. Gouda, Alaa S. Amin, Ragaa, El Sheikh, Magda A. Akl, Sensitive Spectrophotometric Methods for Determination of Some Organophosphorus Pesticides in Vegetable Samples.. 2010. *Chemical Industry & Chemical Engineering Quarterly* 16 (1) 11–18 (2010)
- [13] Genuis, BSJ, Lane, K., Birkholz, D., Genuis, BSJ, Lane, K., & Birkholz, D. Human Elimination of Organochlorine Pesticides: Blood, Urine, and Sweat (BUS) Study of Human Elimination of Organochlorine Pesticides: Blood, Urine, and Sweat (BUS) Study, 2016. vol. 2016, issue i, p. 1–28. <https://doi.org/10.1007/s00244-010-9611-5>
- [14] Yulianti, Nurheti. *Awas Bahaya diBalik Lezatnya Makanan*. 2007.. Yogyakarta: ANDI Yogyakarta
- [15] Ge, X., Tao, Y., Zhang, A., Lin, Y., & Du, D. Electrochemical Detection of Dual Exposure Biomarkers of Organophosphorus Agents Based on Reactivation of Inhibited Cholinesterase. 2013.. *Analytical Chemistry*, p. 1–23. <https://doi.org/10.1021/ac402022p>
- [16] Dachriyanus.. *Spectroscopic Analysis of Structure of Organic Compounds*. 2014. Prints I. Padang: Andalas University Press. Thing. 39. MOH RI. (1980). *Materia*.
- [17] Pecsok RL, Shields LD, Cairns T, McWilliam IG. . *Modern Methods of Chemical Analysis*. 2nd ed.. 1976. New York : John Wiley & Sons, Inc.
- [18] Naveed, S., Nawab, A., Farooq, N. Assay of cimetidine tablets and comparison of local and multinational brands using UV spectrophotometers. 2014. *American Journal of Chemistry and Application*, 1, (4).

Satisfaction Level of School Residents in Implementing A Child Safety System in School

Evi Widowati¹, Herry Koesyanto², Sugiharto³, Anik Setyo Wahyuningsih⁴, Eko Harjanto⁵
 {eviwidowati@mail.unnes.ac.id¹, dhim45ku@gmail.com², giek.kribo@mail.unnes.ac.id³}

Universitas Negeri Semarang, Semarang, Indonesia^{1,2,3}

Abstract. School is one of the places that are vulnerable to safety hazards because school penguins are dominated by children who do not have adequate safety knowledge and tend to panic easily when a disaster occurs. Therefore, the implementation of the safety system, especially for children in schools, is needed to reduce the emergence of injuries and other losses. The purpose of this study was to assess the level of satisfaction of school residents with the implementation of child safety systems. This study used a survey research. The sampling technique used was purposive sampling, coming from student representatives, parents, and school representatives. The results showed that only 48.80% of school residents were satisfied with the child's safety system at school. Dissatisfaction is dominated by answers from parents' representatives, their reasons were dominated by the lack of fulfillment of school facilities/infrastructure and the unavailability of SOPs related to the safety aspects.

Keywords: school, safety system, satisfaction, assessment

1 Introduction

Indonesia is an archipelago country that prone to natural disasters, both prone to natural disasters such as thunderstorms, tropical cyclones, El Nino with drought, La Nina accompanied by floods and landslides, and also vulnerable to earthquake disasters, except Kalimantan [1]. A broader, more human-centered approach to disaster prevention is very important. Disaster risk reduction practices must be multi-hazard and multisectoral, inclusive, and easily accessible to be efficient and effective. The need for collaboration with the public, private sector, civil society organizations, academics, and scientific and research institutions is becoming increasingly apparent to integrate disaster risk into their management practices [2].

Disasters impact physical, psychological, and social aspects, where the impact of disasters on children is far greater than of the adults. Preparedness through teachers is one of the best ways to prepare children for the psycho-social consequences of disasters [3] including digital-based safety education learning, so that class teacher will become more familiar with emergency protocols and able to manage emergency event procedures in the event of an actual disaster [4].

Modern schools are schools that focus a lot on school safety and security, both against external and internal threats in the school [5]. However, in reality, there are still many safety and security problems in schools. The main safety issues in the school climate survey include

teachers in schools, the compactness of school reform, involvement in school growth, school input, student perceptions, teacher-student relationships, safety and maintenance, administration, academic orientation to students, values student behavior, guidance, student-student relationships, parent-school-community relations, teaching management, student activities, justice, order and discipline, parent involvement, resource sharing, student interpersonal relationships, student-teacher relationships, achievement motivation, school development, general school climate, curriculum, achievement, teaching methods, teaching style, learning, personal needs, assessment, ethos/school factors, ethos/individual factors, support, careers, relationships, safety, respect for students, planning and action, the fairness of rules, clarity of rules, and student influence [6].

Creating safe and healthy conditions at work requires elements and principles of occupational safety and health. The elements are Personal Protective Equipment/PPE; a manual for using tools and/or hazard signals; the existence of rules and division of duties and responsibilities; the existence of a workplace that conforms to the standard Work Environment Requirements, such as a workplace that is sterile from dust, dirt, cigarette smoke, gas vapor, radiation, machine and equipment vibrations, noise, a safe workplace from electric current, adequate lighting, comfortable ventilation, and air circulation; work rules and codes of conduct; supporting physical and spiritual health at work; the existence of complete facilities and infrastructure in the workplace; and the awareness in maintaining occupational safety and health [7].

From the description above it can be seen that there are still many safety problems that exist in schools and the need for improvement efforts to create safe, healthy, and child-friendly school conditions. Therefore we need a baseline assessment that involves all elements in the school to assess the extent of their satisfaction with the implementation of the existing school safety system and identify safety problems that exist in the school so that later can be used as a basis for formulating a plan for continuous improvement.

From the above background, the purpose of this study is to assess the level of satisfaction of school residents with the implementation of a child's safety system in SD X.

2 Methods

This study used a survey research design with a cross-sectional approach. The sampling technique used was purposive sampling, with a total sample of 43 respondents from student representatives, parents of students/school committees, and school representatives consisting of principals, teachers, school staff, and security. Data analysis is presented in quantitative and qualitative descriptive terms.

This research was conducted at SD X Yogyakarta as one of the elementary schools located in one of the disaster-prone provinces in Indonesia.

3 Results and discussion

Of the 43 respondents, the study showed that 48.80% or 21 respondents were satisfied with the safety system in SD X, while 51.20% or 22 respondents felt dissatisfied with the existing safety system. In detail, the respondents' ratings are presented in Figure 1.

Based on Figure 1, it shows that 14 children were satisfied with the safety system and 2 children were dissatisfied, 12 people from the school were satisfied with the safety system and 6 people were dissatisfied, and there was 1 committee who was satisfied with the safety system and 8 people were not satisfied.

Most respondents were satisfied with because of the existence of cooperation, responsibilities, and a good family system between the school, students, parents and security, which amounted to 38%; the availability of some facilities and infrastructure that are safe for school residents, namely by 14%; the availability of supporting safety facilities, for example, CCTV, portable fire extinguishers, and security by 14%; and other answers by 34%.

Salvation is a state of survival and free from danger. The situation of a school that is survived will produce a school culture that is responsive and optimizes social learning, emotional and cognitive development of students [8]. Satisfaction can lead to improving the quality of life of individuals [9]. One of the satisfaction levels of citizens depends on the extent of safety can be obtained [10]. School safety aspects do not only focus on mitigating violent incidents because schools have the potential to play an important role in preventing mental, emotional, student behavior, identifying and supporting students when experiencing mental health problems, and reducing violence in adolescents [11].

Besides learning places, schools are also workplaces. Policies on the work safety system can increase employee job satisfaction because employees feel safe and comfortable when in their work environment [12]. Job satisfaction is an individual thing, where every employee wants a guarantee of safety at work. The more safety aspects that are under the wishes of the employee, the higher the level of satisfaction that arises in the employee [13]. The work safety program affects employee job satisfaction, for example, safety socialization activities that are carried out periodically, this shows that the importance of employee safety in work is of high concern [14].

While the reasons for the dissatisfaction of the respondents of this study include: there are still some safety facilities and infrastructure that have not yet been fulfilled and are not child-friendly at 44%; there is no clear SOP regarding child safety management by 30%; the lack of supporting facilities for security and child safety by 13%; lack of socialization and trained personnel to monitor child safety by 9%; food safety and food security of children in schools have not been well monitored by 4%.

Infrastructure which is very minimal and limited to be one of the reasons have not been maximized to implement the safety standards in schools [15]. The most important supporting infrastructure in the school is the emergency response team, which is available at all times [16], disaster prevention map [17], has more than one emergency evacuation area agreed and known to everyone [16].

Also, dissatisfaction can occur due to negligence that can result in the physical injuries suffered by students and teachers. The teacher has the task of caring for students and providing adequate supervision. Teachers must take extra care of students in playgrounds, sports fields, and in-class or when sightseeing. If there is negligence on the part of the teacher in maintaining the students, the school must be able to take responsibility for it. Negligence can also arise in the form of providing unsafe school equipment and environments. The higher the risk or potential for danger, the greater the task assigned to the teacher [18].

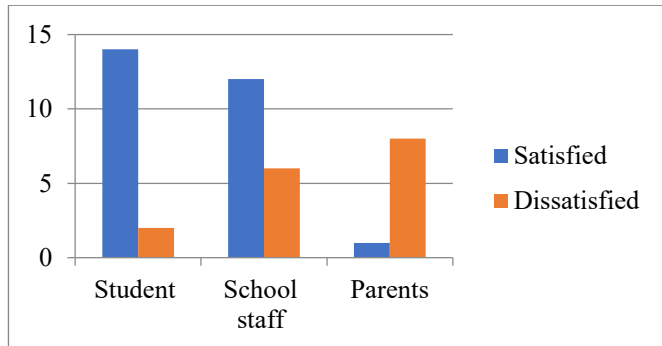

Fig. 1. School citizens' satisfaction with school safety systems evaluation

From the dissatisfaction, respondents gave some input to build a safety system in SD X, including 20% giving input on the consistent efforts in completing and monitoring infrastructure in schools; prepare and implement SOPs related to child safety and security systems by 22%; provide training, outreach, and direction to all school residents by 20%; increase cooperation and coordination with related parties to monitor child safety in schools by 16%; the addition of security and safety support facilities by 8%; conduct disaster response simulations, at least for natural disasters and fires in stages by 4%. Other inputs include incorporating disaster-based school-based curriculum and the existence of foundation support in funding, program provision, and safety infrastructure in schools that are in line with child safety and friendly standards.

From the input of respondents, it can be seen that the majority of respondents provided input related to the preparation and implementation of SOPs for safety in schools. Systematic work procedures in carrying out tasks in the workplace are the most important factor in the occupational safety and health management system. A job requires guidance as a guide for officers to reduce the risk of an accident. Every worker needs to follow established work procedures. This is important to ensure the safety and health of these workers. The procedure is usually outlined in the form of Standard Operating Procedures (SOP) [19].

Safety procedure/SOP is a standard or procedure that can provide information to workers to carry out their duties and responsibilities safely and comfortably to avoid illness or accidents due to work, to achieve the goals set by a workplace [19].

SOP can provide convenience to every worker in carrying out their duties so that they can provide quality work results, in addition to avoiding the risk of exposure or contracting diseases that can arise from a particular job. Understanding, attitude, and awareness are important things that must be possessed by every employee in implementing and complying with SOP so that every worker can do his job properly and correctly [19].

Safety education is very much needed for elementary school children because not many students know about how mitigation efforts they have to do and from which sources of information related to disaster mitigation can be accessed, so knowledge about disaster mitigation must be included in the curriculum content in schools starting from elementary school level including activities in the laboratory to maintain the safety of students [20]. Besides, it was also strengthened by the provision of socialization that aims to increase the capacity of the community especially elementary school students so that from the beginning

they can understand the importance of disaster mitigation to reduce the risk of loss due to disasters [21,22].

On the other hand, knowledge and skills about disaster mitigation education are important to be mastered by the teacher, because in the classroom teachers must be able to equip students with theoretical knowledge and practical knowledge about education about disasters. The results showed that the average value of the basic knowledge of disasters owned by the teacher was good at 7.5. While the average value of the ability to assess the potential for disaster is 7.2 (included in the sufficient category) and the average value of attitude to respond to a disaster is 7.1 (included in the sufficient category) [23]. To overcome the existing limitations, a partnership or collaboration effort is needed, for example with the Local Health Office and Puskesmas (community health centers) for the preparation of the UKS (Indonesia: Unit Kesehatan Sekolah; English: School Healthcare Unit) program [24]. UKS is one of the strategic units in schools that can be integrated into disaster risk reduction activities.

Providing knowledge and education about disaster preparedness or emergency response to elementary school children and all staff in the school environment is one way to introduce early on to disaster response. Simulations or providing training are important to increase knowledge and speed of evacuation and can increase the enthusiasm and activeness of children in training or the provision of materials related to emergency response [25]. Also, training/simulation of emergency response in schools is a learning process carried out with systematic procedures to increase the knowledge of all school residents in dealing with disasters while increasing individual competencies related to safety aspects. Disaster preparedness training and simulation will be able to broaden students' and school insights in dealing with disasters and be able to take appropriate attitudes and actions when disaster strikes [26].

4 Conclusion

The conclusion in this study is that most school residents in SD X were not satisfied with the current safety system at the elementary school, it can be seen that 48.80% of school residents were satisfied with the child's safety system at school while 51.20% of respondents felt unsatisfied. Dissatisfaction was dominated by the answers from the parents' representatives, while answers to satisfaction with the safety system at school were dominated by answers from students. Reasons for dissatisfaction were dominated by the lack of fulfillment of school facilities and infrastructure and the unavailability of SOPs related to the safety aspects of children. From these results, it can be concluded that the majority of school residents felt unsatisfied with the application of the child safety system in the current school. The advice given is the fulfillment of child-friendly safety facilities and infrastructure in schools, preparation of SOPs, training, strengthening networks, and the application of safety grievance mechanisms for continuous improvement.

The limitation in this study is that the research data was taken when the COVID-19 pandemic occurred in 2020 so that the data was taken through an online network system either filling out questionnaires via Google Form, social media (whatsapp) or using other cell phone media.

Acknowledgments

Implementation of this research was funded by the “Penelitian Unggulan Perguruan Tinggi 2020” as The Competitive Research Grant Scheme by Sport Science Faculty of Universitas Negeri Semarang. Thanks for the services, opportunities, and trust to Sport Science Faculty, Universitas Negeri Semarang.

References

- [1] Nasional GTPPRB dalam SP. Strategi Pengarusutamaan Pengurangan Risiko Bencana Di Sekolah. Jakarta, Indonesia: Kementerian Pendidikan Nasional; 2010. p. 1–41.
- [2] UN. Sendai Framework for Disaster Risk Reduction 2015-2030. In: The Third UN World Conference. Sendai, Japan: UNISDR; 2015. p. 1–37.
- [3] Elangovan AR, Kasi S. Psychosocial Disaster Preparedness For School Children By Teachers. *Int J Disaster Risk Reduct* [Internet]. Elsevier; 2015;12:119–24. Available from: <http://dx.doi.org/10.1016/j.ijdr.2014.12.007>
- [4] Schmidt J. Notes on national earthquake education programs in Israel. *Procedia Eng* [Internet]. Elsevier Ltd; 2018;212:1265–72. Available from: <https://doi.org/10.1016/j.proeng.2018.01.163>
- [5] Mowen TJ. School Safety [Internet]. 2nd Editio. Vol. 21, *International Encyclopedia of the Social & Behavioral Sciences: Second Edition*. USA: Elsevier Ltd; 2015. 107-111 p. Available from: <http://dx.doi.org/10.1016/B978-0-08-097086-8.45081-6>
- [6] Skiba R, Simmons AB, Peterson R, Forde S. *The Handbook of School Violence and School Safety From Research to Practice*. Jimerson SR, Furlong MJ, editors. London: Lawrence Erlbaum Associates, Publishers; 2006. 157-169 p.
- [7] Ayu Er. Meytha Gayatri I. Hubungan Keselamatan dan Kesehatan Kerja (K3) dengan Kinerja Karyawan pada PT. UOB Indonesia Cabang Bengkulu. *Ekombis Rev*. 2015;3(2):185–96.
- [8] Awang M, Suyanto N. Pendekatan keselamatan dan kesejahteraan pelajar untuk sekolah-sekolah di Malaysia. *Manag Res J*. 2017;7(1):139–53.
- [9] ‘Ulyani Mohd Najib N, Aini Yusof N, Zainul Abidin N. Student residential satisfaction in research universities. *J Facil Manag*. 2011;9(3):200–12.
- [10] Husin HN, Nawawi AH, Ismail F, Khalil N. Correlation Analysis of Occupants’ Satisfaction and Safety Performance Level in Low Cost Housing. *Procedia - Soc Behav Sci* [Internet]. Elsevier B.V.; 2015;168:238–48. Available from: <http://dx.doi.org/10.1016/j.sbspro.2014.10.229>
- [11] Safety FCOS. *School Safety*. Washington, D.C.; 2018.
- [12] Mardiana Yusuf R, Eliyana A, Novita Sari O. The Influence of Occupational Safety and Health on Performance with Job Satisfaction as Intervening Variables (Study on the Production Employees in PT. Mahakarya Rotanindo, Gresik). *Am J Econ*. 2012;136–40.
- [13] Aldini RL, Afrianty TW. Pengaruh Sistem Manajemen Keselamatan dan Kesehatan Kerja (SMK3) terhadap Kepuasan Kerja serta Dampaknya terhadap Kinerja Karyawan (Studi pada Karyawan PT. INDOLAKTO Purwosari). *J Adm Bisnis*. 2019;72(1):212–21.
- [14] Fajri K, Utami HN, Prasetya A. Pengaruh Program Keselamatan dan Kesehatan Kerja (K3) terhadap Kepuasan Kerja dan Kinerja Karyawan (Studi Pada Karyawan PT Brantas Abipraya (Persero) dalam Proyek Pembangunan Wisma Atlet Kemayoran). *J Adm Bisnis*. 2017;46(1):11–9.
- [15] Ramadhan GT, Ismara KI. Pengaruh Pengetahuan dan Sarana Prasarana terhadap Karakter Siswa terkait Kesehatan dan Keselamatan Kerja Siswa. *E-Journal Univ Negeri Yogyakarta*. 2016;6(4):303–11.
- [16] O’Connor P. Pedagogy of love and care: shaken schools respond. *Disaster Prev Manag* [Internet]. Emerald; 2013;22(5):425–33. Available from: <https://doi.org/10.1108/DPM-10-2013-0176>
- [17] Chen C, Lee W. Damages to school infrastructure and development to disaster prevention education strategy after Typhoon Morakot in Taiwan. *Disaster Prev Manag An Int J* [Internet]. Emerald; 2012;21(5):541–55. Available from: <https://doi.org/10.1108/09653561211278680>
- [18] Newnham H. When is a teacher or school liable in negligence? *Aust J Teach Educ*. 2000;25(1):45–51.

- [19] Hariyono W, Awaluddin YF. Standar Operasional Prosedur (SOP) Aspek Keselamatan dan Kesehatan Kerja (K3) di Unit Sarana PT Kereta Api Indonesia (Persero) Daerah Operasi VI Yogyakarta. In: Seminar Nasional Teknik Industri Universitas Gadjah Mada. Yogyakarta: Program Studi Teknik Industri Universitas Gadjah Mada; 2016. p. 25–32.
- [20] Hutasoit FE, Widowati E. Gambaran Penerapan Safety Education (Pendidikan Keselamatan) di Sekolah Dasar. *J Heal Educ.* 2017;2(1):66–72.
- [21] Farida M, Alimuddin I, Maulana A, Irfan UR, Jaya A, Sultan, et al. Sosialisasi Bencana Geologi dan Mitigasinya di Sekolah Dasar Islam Terpadu (SDIT) Ar-Rahmah Makassar. *TEPAT J Teknol Terap untuk Pengabdian Masy.* 2019;2(2):66–73.
- [22] Adnyani IAS, Seniari NM, Supriyatna, Natsir A, Nababan S, Ratnasari D. Keselamatan dan Kesehatan Kerja (K3) Laboratorium Siswa SMPN 7 Mataram. In: Seminar Nasional Pengabdian kepada Masyarakat. Mataram: LPPM Universitas Mataram; 2019. p. 170–4.
- [23] Bashori I. Peran Guru terhadap Kesiapsiagaan Sekolah dalam Menghadapi Bencana Banjir di Kelurahan Sewu Kecamatan Jebres Kota Surakarta. Surakarta; 2013.
- [24] Gurning FP, Daulay AJ. Pembinaan Puskesmas terhadap Pelaksanaan Program Usaha Kesehatan Sekolah di Wilayah Kerja Puskesmas Padang Matinggi Kota Padangsidimpuan. *Jumantik.* 2018;3(1):100–18.
- [25] Septiadi A. Perbedaan Sistem dan Pengetahuan Tanggap Darurat Bencana Kebakaran sebelum dan sesudah Pemberian Pelatihan pada Gedung Sekolah Dasar Sang Timur Semarang. *J Kesehat Masy.* 2012;1(2):635–43.
- [26] Daud R, Sari SA, Milfayetty S, Dirhamsyah M. Penerapan Pelatihan Siaga Bencana dalam Meningkatkan Pengetahuan, Sikap, dan Tindakan Komunitas SMA Negeri 5 Banda Aceh. *J Ilmu Kebencanaan Pascasarj Univ Syiah Kuala.* 2014;1(1):26–34.

Classification of Arch Height Index and Arcus Pedis to The Agility

Fajar Awang Irawan¹, Limpad Nurrahmad², Dhias Fajar Widya Permana³
 {fajarawang@mail.unnes.ac.id¹, limpad.edu@mail.unnes.ac.id², dhiaspermana17@mail.unnes.ac.id³}

Universitas Negeri Semarang, Semarang, Indonesia^{1,2,3}

Abstract. The purpose of this study was to classify the Arch Height Index (AHI) and Arcus Pedis to the agility. Total 48 participants with good health and has no ankle and knee injuries. This study using descriptive quantitative method with a test and measurement approach and one-shot case study design. Wet test was used to measure AHI and Arcus Pedis, while agility using Dodging Run Test. The results showed that the AHI data had an average 0.149 (\pm 0.125), Arch Index 0.371 (\pm 0.072), and agility test was 15,436 (\pm 0.493). The study found that there was no significant relationship between Arch Height Index and agility. AHI and Arcus Pedis were not a determining factor in the results of agility tests. This study concludes that Arch Height Index and Arcus Pedis has no relationship with the results of the agility. Monitoring in increasing agility needs to be prioritized for performance improvement.

Keywords: arch height index, arcus pedis, agility

1 Introduction

Health is an absolute necessity for everyone. To get health, humans are willing to do physical activity and exercise for the achievement of life goals. In today's modern life, humans cannot be separated from sports activities either as one of a special occupation, as entertainment, recreation, livelihood, health and culture. One of the most important parts in exercising and affecting the musculoskeletal and skeletal structures in the foot is the arch foot or Arcus Pedis. Arcus Pedis in terms of human body motion can also be called foot type. The stage of curvature of everyone's feet was not the same. In general, foot type can be divided into three, there are normal arch (Normal Foot), high (Arch Foot), and low (Flat Foot). According to the research study by Lendra & Dody [1], twenty percent of adults have flat feet and almost all newborns do not have arches like normal adults. Curved human feet are a special feature of humans that are not seen in other creatures. The main basis of the arches comes from the shape of the bones although the ligaments, tendons and muscles that form the strength and stability of the foot in supporting the establishment of the body upright. Flat foot is one of the most common conditions found in human feet. Flat foot, also called pes planus or fallen arches refers to a medical condition where the arches are flat. All parts of the foot insole attached to or almost attached to the ground, in another meaning all the part of the feet stepped on the ground. Arcus pedis in humans is formed with the intention that the feet are

more stable when standing tread, which can distribute weight evenly to a wider area. Arcus Pedis also serves to increase speed and agility during walking and provide stabilization and flexibility [2].

Deformities of the feet can affect human health, several events that occur make the condition easily tired when walking or running, irritation of the plantaris muscles and irritation of the fascia plantaris. These impacts and abnormalities can also cause tension in the muscles around the legs and physiotherapy can handle in the form of medial arch support, stretching plantaris muscles, and strengthening exercises for plantaris and leg muscles. Injuries that have a risk to the performance when exercising [3,4,5] or when competing were at ankles and knees can also be caused by the form of Arcus Pedis. Arcus Pedis that does not grow normally causes impaired balance, unstable motion, deformity continues, complaints of fatigue if walking prolonged, heel shoes wear out quickly, injuries to excess surfaces, and the onset of pain. The basic thing and the possibility of being a bad impact on a career is the possibility of being unacceptable when register as a soldier or police officer or also the limitations in achievement in some sports and long-standing jobs and long-distance walking [6]. A person's ability when perform physical activity can be done through several test items contained in the components of physical conditions. Some of these items include tests of strength, speed, balance, endurance, explosive power and others. The type of the Arcus Pedis specialized in the lower extremity support the upper extremity in standing of the human body.

Based on research by Sahabuddin [7] it was found that the higher of Flat Foot grade was in the lower of dynamic balance possessed level. Darwis [8] found that agility in the Normal Foot group had better results when compared to the Flat Foot group. Hang Yu [5] in his study stated that there was no relationship between vertical jump using two feet to the height of the foot arch they have. The discovery of the vertical jump and start sprint prefix significantly influences the appearance in the human arch foot in a static or dynamic balance. Based on the results of previous research literacy conducted by the author through the method of observation and literacy studies found that college student of Sport Sciences has different foot types. The physical condition component also likely to affect the results carried out by each individual with the Arcus Pedis type when conducting a physical test, especially on the agility component. The purpose of this study was to classify the Arch Height Index using the measurement of the Arcus Pedis in knowing the agility it possesses. Recommendations and suggestions are used to improve performance in increasing agility and injury prevention.

2 Methods

This study using descriptive quantitative method with a test and measurement approach. One-shot case study design was used to determine the influence of Arch Height Index (AHI) and the type of Arcus Pedis possessed by each participant whose results can be seen using agility tests with Dodging Run Tests on student college of Sport Science Universitas Negeri Semarang. Total 48 participants attend in this study and the authors did not differentiate between men and women because they both had passed the tests and measurements in the class. All participants came from the various sports background such as athletics, soccer, volleyball, basketball, pencak silat, hockey, and handball. All participants were in good health and has no ankle and knee injuries that are likely to interfere the test. All participants agreed on the procedure given by signing and full fill the informed consent as proof of their

willingness to participate in this study and accept all risks when the study was conducted. This study already qualified from the review of Health Research Ethics Committee of Universitas Negeri Semarang, Indonesia based on the Standards and Operational Guidance for Human Participants regarding WHO 2011.

To determine the research sample, a purposive sampling technique was used. This sampling technique based on criteria established by the author. These criteria include active Sports Science college student, aged between 17-24 years. Willing to be a participant by proven to full fill in informed consent, and be present to take tests and measure foot type test. After completing the identity, the next procedure was to do foot type test using a wet test based on Harris et al., [9] by attaching the soles of the feet to the ink in the mat and then placed on paper until the soles images of the feet and curves were visible. AHI data was obtained by measuring the length of the hallux valgus on the foot and arch index. The results obtained were then included in the formula as in the Hu [10] study. Furthermore, the agility tests were carried out and completed with data analysis using statistical analysis to find the relationship between AHI and Arcus Pedis to the agility.

3 Results and discussions

Associated with extraordinary events experienced globally about Covid-19, with all the capabilities carried out researchers have tried to collect primary data and relevant information to add references and research data in analyzing and classifying Arch Height Index and Arcus Pedis.

Table 1. Participant's personal data

n = 48	Mean	SD	Min	Max
Height	166.58	5.07	151	178
Weight	61.94	7.99	46	85
BMI	21.99	2.71	16	31.64
Age	20.58	0.871	19	23

Table 1 explains the participants personal data that were present in the study. In this study 48 participants with an average of Height 166.58 (\pm 5.07), Body Weight 61.94 (\pm 7.99), Body Mass Index 21.99 (\pm 2.71), and an average of Age 20.58 (\pm 0.871). The number of participants who join and attended were following the procedures and sampling techniques in the study. The criteria determined are Sports Science college students who are active, aged 17 to 24 years, willing to become participants by proven to full fill informed consent, present to take agility tests and foot type Arcus Pedis measurements to completion.

Table 2. Descriptive research data

Variable	Mean	SD	Min	Max
Arch Height Index (AHI)	0.149	0.125	0.095	0.947
Arch Index (AI)	0.371	0.072	0.214	0.55
Agility Test	15.436	0.493	14.06	16.46

The results showed that the AHI data had an average of 0.149 (± 0.125), Arch Index 0.371 (± 0.072), and the agility test was 15,436 (± 0.493). The result showed that there was no significant relationship between Arch Height Index and agility. This also happens to Arch Index (AI) which the results of the Agility Test have no relationship to the significance value of $.238 > .005$. Based on the statistical results above in the partial correlation test it can be seen that the Arch Height Index (AHI) and Arch Index (AI) to measure Arcus Pedis have no significant effect on the results of the Agility test. Thus, AHI and Arcus Pedis were not a determining factor in the results of agility tests held by college students of Sports Science.

Although the average of participant's Arcus Pedis has Flat Foot criteria (42 people) in this study, generally any criteria held in Arcus Pedis was a major device to support the upper extremity and also to be used as a media for moving, walking, and running. The foot part is very important of the limb and functions as a lever. Foot part also as the recipient of the deformity force in carrying out physical activity. The benefit of having the Arcus Pedis as support for bodyweight will be divided in frontally to balance the front and back and sagittal for the right and left. When standing normally, half of the weight was supported by the heel and half by the metatarsal, one-third of the body weight was supported by the metatarsal bone and the rest by the metatarsal head. The center of pressure load will also be spread evenly on the front of the sesamoid bone ostarsal ositum capitulum I and metatarsal osseum capituli II-IV and the sole of the foot in the medial processus tubercis calcanei. Whereas the center of gravity was in the middle of the sagittal plane of the body and there was no part of the body is working heavier. This will be a different story if the heels of both feet were placed on a stand so that the heel is higher like in the plantar flexion position or like wearing high heels. In this position, the center of pressure will be greater in the forelegs to support most of the bodyweight which was previously a function of part of the heel [11].

Classification of Arch Height Index (AHI) and Arcus Pedis to the agility is very important in daily activities. The problems in this study raised about AHI and Arcus Pedis on the agility of college student Sports Science. The author has the notion that the shape of the foot has an influence on the results of agility tests by college students of Sports Science. However, the results of this study were contradictory, because there was no significant relationship either between AHI and Arch Index in Arcus pedis with the agility possessed by college students of Sports Science. Normal foot shape with good agility results does not guarantee someone was able to display good performance and vice versa. The results of this study also stated that there was no relationship between AHI and Arcus Pedis on agility because the person has several possibilities such as a component of good physical condition, proper shoes with foot contours, and effective movements.



Fig. 1. Type of arcus pedis

Source : Williams & MacClay, 2000 (14)

The type of Arcus Pedis in Figure 1 explains that the left foot is an example figure of a Flat Foot, while the middle is the Normal Foot type, and the right is the High Arch. Arcus Pedis measurement results showed that 48 participants 6 people had Normal Foot criteria, whereas for Flat Foot criteria there were 42 people, and no participants had the criteria of the High Arch in this study. The results of the agility test conducted in this study found that 7 people had Good criteria, and 41 people had Average criteria. The results of this agility test, in general, cannot be used as the main reference in determining the success of someone who has a type of the Arcus Pedis in having Good agility. Although none of the 48 participants who took part in this study had Arch Foot criteria. However, the results of this study found that 6 people have Normal Foot criteria and 42 people have Flat Foot criteria with consideration of having areas on the soles of the feet by the calculation standards in the wet test. Subsequent findings state that there was no significant relationship that states the Arch Height Index and Arch Index affect agility in college students of Sports Science. Santoso, [12] gave the advice in his study to maintain cleanliness and health for the feet because the treatment was very appropriate for someone who has Flat Foot. This study was also in accordance with the recommendations from the author through this study that participants who have Flat Foot should choose the right shoes in accordance fit with the shape of foot insole. The aim was to provide comfort to the legs when walking or running. The purpose of giving insole to the foot was to give a cushion to Hallux Valgus that it has an arch so that the foot has a reflection when making movements. Another aim was to reduce the pain or injury to the hallux that was usually unable to stand, walk, or even run for long periods, especially in people who have low AHI. Another study from Williams & MacClay [13], stated that the measurement of Arcus Pedis can be used to determine the characteristics and Medial-longitudinal Arch which functions for the validity and reliability in the measurement foot insole.

Body Mass Index classification in this study showed that the criteria for Underweight were 2 people, 31 people have Ideal body weight, 9 people were in Overweight criteria, then 5 people have level I Obesity criteria, and 1 person in level II Obesity criteria. These results indicate that there was a good correlation even though the average participant has an Ideal body weight and logically the participant was able to practice the agility test Well even with varying BMI conditions. Need accurate measurements using a medical examination to determine the exact criteria of the Arcus Pedis and Musculoskeletal system [14],[15] on the foot insole for monitoring Arcus Pedis and performance for athletes. The limitation of this study was the author does not have data on the Arcus Pedis through the family history of each participant that can be used as the basis for the status of the Arcus Pedis for each participant has. Body fat composition data can also be a factor in determining fat in the legs which can interfere with the research data. A history of injuries to the feet, bones and joints that have not been recorded can also affect the results of the study. Further research was needed to supplement the secondary data to explain why Arch Height Index (AHI) and Arcus Pedis have no relationship to agility in college students of Sport Sciences. It is hoped that the results of this study can be a reference for further research to be able to improve the agility test and efforts to prevent injuries.

4 Conclusions

This study concludes that the Arch Height Index related to the measurement of Arcus Pedis has no relationship with the results of the agility test of college students Sports Science. Not all Arcus Pedis of the participant are purely derived from the complete anatomical shape of humans. Fat deposits on the soles of the feet, the influence of hallux Valgus on human feet, Varus and Valgus on human feet can also be a factor causing changes in the contours of the soles of human feet. It is necessary to have a medical examination related to Arcus Pedis to know the complete data and check periodically to find out if there are changes or injuries experienced. Monitoring in increasing the ability of agility tests needs to be considered intensively to overcome the constraints experienced and immediately improve capabilities in the agility component owned.

Acknowledgments

This study is part of the research about the classification of Arch Height Index and Arcus Pedis to The Agility. The author would like to thank Faculty of Sports Science, Universitas Negeri Semarang for funding of this research.

References

- [1] Bachtiar, F. (2012). *Gambaran Arkus Pedis Pada Mahasiswa Fisioterapi*. Universitas Hasanudin.
- [2] Darwis, N. (2016). *Perbandingan Agility Antara Normal Foot dan Flat Foot pada Atlet Unit Kegiatan Mahasiswa Basket di Kota Makasar*. Universitas Hasanudin.
- [3] Harris, E. J., Vanore, J. V., Thomas, J. L., Kravitz, S. R., Mendelson, S. A., Mendicino, R. W., ... Gassen, S. C. (2004). *Diagnose and Treatment of Pediatric Flatfoot*. *The Journal of Foot & Ankle Surgery*, 43(6).
- [4] Hodge, S. D. (2010). *Anatomy for Litigator. The Anatomy of The Foot*, 205–208.
- [5] Hu, Y. (2016). *The Relationship Between Foot Arch Height and two-legged Standing Vertical Jump Height in Male College-age Students*.
- [6] Idris, F. H. (2010). *Filogeni dan Ontogeni Lengkung Kaki Manusia*. *Majalah Kedokteran Indonesia*.
- [7] Irawan, F. A., Chuang, L.-R., Peng, H.-T., & Huang, S.-K. (2016). *A Biomechanical Baseball Pitching: Is the curveball has more risk than fastball?* *華人運動生物力學期刊*, 13(2), 55–63. <http://doi.org/10.3966/207332672016121302002>
- [8] Irawan, F. A., & Long-Ren, C. (2015). *Pitching Biomechanics and Injury Prevention to Improving Performance for Young Baseball Pitchers – A review*. In 1st UNNES International Conference on Research Innovation & Commercialization for Better Life.
- [9] Irawan, F. A., Putra, A. A., & Chuang, L.-R. (2019). *Physical Fitness of Adolescent Smoker*. *Jurnal Kesehatan Masyarakat*, 14(3), 398–403.
- [10] Lendra, & Dody, M. (2007). *Pengaruh Antara Kondisi kaki Datar dan Kaki Dengan Arkus Normal Terhadap Keseimbangan Statis Pada Anak Berusia 8 - 12 Tahun di Kelurahan Karangasem Surakarta*. Surakarta.
- [11] Neuman, D. A. (2010). *Kinesiology of The Musculoskeletal System*. St. Louis, Missouri: Mosby Elsevier.
- [12] Sahabuddin, H. (2016). *Hubungan Antara Flat Foot Dengan Keseimbangan Dinamis Pada Murid TK Sulawesi Kota Makasar*. Universitas Hasanudin.
- [13] Santoso, D. (2011). *Perawatan Tepat Bagi Anda Yang Memiliki Telapak Kaki Datar (Flat Feet)*. *Sport Injuries & Rehabilitation*.

- [14] Williams, D. S., & MacClay, I. S. (2000). Measurements Used to Characterize the Foot and The Medial Longitudinal Arch: Reliability and Validity. *Physical Therapy*, 80(9), 864–871.
- [15] Winata, H. (2015). Kaitan Pemaikaian Sepatu Hak Tinggi Dengan Lordosis Lumbal. *Jurnal Kedokteran Meditek*, 20(52).

Physical Activities and Second Language Proficiencies; A Systematic Review

Fatona Suraya¹, Hendi Pratama², Puput Arfiandhani³
{suraya@mail.unnes.ac.id¹, hendi.pratama@mail.unnes.ac.id², puput.arfiandhani@fpb.umy.ac.id³}

Universitas Negeri Semarang, Semarang, Indonesia^{1,2},
Universitas Muhammadiyah Yogyakarta, Bantul, Indonesia³

Abstract. Research has shown that physical activities provide a positive effect on cognitive performance, including short-term and long-term memory. However few have focused on its effect on the second language (L2). This paper is a systematic literature review (SLR) paper that aims to identify, assess, and interpret related research papers to gain a better understanding of the positive possible effect of several types of physical activities toward L2 performances. Eight different papers published between the years 2007 to 2019 are analyzed in terms of the physical activities, the research method, and the L2 domain being affected. It suggests that there is a positive association between physical activities and L2 learning. The positive effects are being discussed.

Keywords: physical activities, second language performance, systematic literature review

1 Introduction

Research has shown that physical activities provide a positive effect on cognitive performance [1-4], including short-term and long-term memory [5] however few have focused on its effect on the second language (L2). This systematic literature review tries to seek the trend of research focusing on the effect of physical activities to L2 performances and analyze on what area of L2 performance benefits more from the physical activities by examining several published papers in the field. Physical activity (PA) defines as any bodily movement produced by skeletal muscles that require energy expenditure, including playing. Second language (L2) defines as any language that a person uses other than a first or native language (L1). This study aims to identify sample characteristics, research methods, and type of physical activities intervention being implemented in research based on physical activities and L2 performance as well as exploring the language domain being affected by the physical activities.

2 Methods

2.1 Review method

This study employs a systematic literature review as its methodical approach. According to Moher, a systematic review is a process of reviewing which focus on answering a formulated question that employs systematic and explicit methods to specifically pick and choose relevant researches and to gather and analyze data from papers which are selected to be reviewed [6] This study follows the common review protocol of a systematic review as explained in the article of Five steps to conducting a systematic review namely framing the research questions, identifying relevant publications, assessing the quality of studies, summarizing the evidence, and Interpreting the findings [7].

2.2 Framing research questions

The research question in this study aimed to maintain the focus of the review. The question guiding this study is what kinds of research methods and physical activities intervention being used in the studies on physical activities and L2 performance? How do the physical activities affect the L2 performance?

2.3 Identifying relevant publication

To gather as many relevant citations as possible, a variety of second/foreign language, sports, physical activities, language assessment were searched to identify primary studies of the relation of physical activities toward L2 proficiencies. A wide range of internet searching engines was supplemented by hand searching to provide references. Here is the list of the digital database searched: google scholar, Ebsco, ScienceDirect, Asian-EFL-journal, Researchgate, Natecla, journals-PLoS, PubMed. The last search was conducted on July 9, 2020. The inclusion and exclusion criteria modifying a systemic review research model on engineering research[8] are explained in table 1.

Table 1. Inclusion and exclusion criteria

Inclusion	research in an academic setting using large and small scale data sets research discussing and comparing the various model of motor/physical activities intervention toward L2 performance For research which has both conference and journal version, only the journal version is included Research within the last 15 years (2006-2020)
Exclusion	research in a non academic setting Research not written in English The article that focused on physical activities and neurocognitive function The article that is not published in a journal

Software package EndNote was employed to store and manage the search result. This effort resulted in 51 related articles. Their potential relevance was examined according to the inclusion and exclusion criteria of table 2. Of 31 articles were excluded as irrelevant. The full papers of the remaining 20 articles were assessed to select those primary studies in physical activity intervention and L2 performance. This selection excluded 13 studies and left 8 articles in the review. The article comes from 5 countries, published in 4 different journals between the year 2007 to 2019.

2.4 Assessing study quality

In addition to the inclusion and exclusion criteria in table 2, the quality of primary studies, and their relevance to the research questions were considered. The complete list of selected studies is presented in table 3. Selected Article whereas the quality assessment of studies on physical activities and L2 performance are explained in table 3.

Table 2. Quality assessment of the study

Quality categories	High	Moderate
Population	More than 50	Between 50 to 12
Intervention	Physical activities and language input with equal proportion	Physical activities and language input with an inadequate proportion
Comparison	various type of physical activities and various aspect toward L2 performances	single types of Physical activities toward a single aspect of L2 performances
Outcomes	Adjustments for at least three indicators	Adjustment for at least one indicator
Context	Study in early childhood education and adults	Study in children in general

2.5 Summarizing the Evidence

This paper restricts to summarizing the finding narratively. The association between physical activities and L2 performances, in general, was examined in 8 studies. The details of the summary are discussed in chapter 3 Result. Whereas the last stages of review namely interpreting the finding will be clearly explained in chapter 4 discussion.

3 Results and discussions

Paper by Winter [9] on High impact running improves learning examines the learning performance examine 27 male athletes directly after two conditions: high impact anaerobic sprints and low impact aerobic running. It involves an immediate and long term study. The participants were given a neuropsychological test which was analyzed using the Pearson correlation coefficient and fitness test to measure their physical fitness level. The activity followed by exercise intervention which divided into three conditions namely relax (control group), moderate and intense as the experiment group. The individual heart rate was taken into consideration before and after each intervention. Immediately after the intervention, the experiment group rated their perceived exertion on the Borg-Scale. The learning intervention given in form of correct pairing, a visually presented daily object, and a novel word (e.g., car and /glump/) and the participant need to decide correct or not by pressing one of two keys with their right hand. Of 600 training trials were prepared for the participants. Retention was given a week after and 6-After 8 months post, respectively. The treatment showed a positive effect on learning. The intense subject condition learns 20% faster after two sprints of less than 3min each compared to moderate and relaxes conditions. It contends that quick exercise-initiated consequences for a mind complex learning task straight with neurophysiological correlates analysis(changes in peripheral catecholamine or BDNF levels) in people. The

analysts contend that increasingly supported BDNF levels during learning (levels after extraordinary exercise less levels subsequent to learning) were identified with better transient learning achievement, and outright dopamine and epinephrine levels after serious exercise was identified with better middle of the road (dopamine) and long haul (epinephrine) maintenances of the novel vocabulary. Thus, exercise-induced learning improvement for short-term memory and long term memory in terms of word memory process and novel word recognition. However, this paper was only focused on male athletes which as we could assume have high motivation for passing the physical intervention.

The next article on the Physical activity and mental performance in preadolescents: Effects of acute exercise on free-recall memory were also testing word memory process in a visual test form[5]. The physical exercise involved were team games and circuit training started by warming up activities and closed by cooling down activities that were conducted during the Physical Education (PE) lesson. The third group was the baseline group which did not proceed by any lesson. There were two conditions of free-recall test namely immediate and delay recall. The intensity of the exercise during the PE lesson was observed by recording Heart Rates (HR) and rating of perceived exertion (RPE). RPE was recorded after the PE lesson and before starting the memory test. The data were analyzed using statistical analysis. The result of the study explained that for immediate recall group following team game score higher for both primacy and recency portions than in the baseline session. On the other hand, delayed recall groups score higher in the recency portion after aerobic training activities and team games. The research suggests that acute submaximal exercise facilitate memory storage in term of free-recall memory of random words. Further, the study discussed an exercise-induced benefit for memory performance that cannot be confounded with learning effects, it does improve the mastery of vocabulary but does not equally improve the learning. Interestingly, this study refers to the previous study discussed in this paper [9] arguing that the short-term effect of exercise may also have mental health outcomes in the long-term memory through examining BDNF levels during learning after exercise.

Article by Schmidt-Kassow's et.al discussing exercising during learning improves vocabulary acquisition[10] The study aimed to clarify whether the dynamic movement during learning stimulates by physical activities influences verbal learning compared to learning in static condition. The study involved two groups, spinning group, and passive groups, and it measured behavioral and electrophysiological responses to memory materials. They were given matching and miss matching words and were asked to analyze the correct one. The study indicates that simultaneous physical activity during foreign language vocabulary learning facilitates the memorization of new items. Interestingly, this study strengthens the previous study on comparing different learning conditions (static condition versus dynamic condition) toward the vocabulary memorization [9]. In addition, this study examines the long-term effect of regular physical activity during learning toward the learning process and was able to prove the hypothesis that the spinning group showed significantly better performance of foreign language vocabulary testing each day even after three weeks of learning. Subjects who were physically active in the encoding phase have a larger N400 effect and have better performance in vocabulary tests. However, this study involved a very small sample of 12 healthy subjects, 4 males and 8 females.

The next article examining the use of Total Physical Response (TPR) method in Early childhood foreign language[11]. TPR is merging speech and action coordination in teaching (the foreign language) through physical activity. It involves no texts in the teaching environment but there is teaching via games, dance-songs, stories with actions to attracts

children's attention. The paper discussed the positive view on implementing TPR to teach early childhood foreign language classrooms using a narrative qualitative approach. It argues that TPR activities that are full of action benefit those kinesthetic learners. The objective of TPR is not in writing or reading but more likely to speaking and listening as the aim is to introduce new vocabulary to children in a more meaningful context and invite children to respond (verbally or non verbally).

Research on integrated gesture and physical activities on early childhood's foreign language vocabulary learning differentiate the movement type into part-body movement (gesture) and whole-body movement (physical activity) in given foreign language vocabulary tasks [12]. It assumed that emerging movement into a cognitive learning task may be beneficial for learning because of its cognitive and psychological aspect, meaning that enacting the words through physical exercises will give positive cognitive effects. Four conditions were implemented namely integrated physical exercise, non-integrated physical exercise, and gesturing condition and conventional condition. In the integrated physical exercise, children learning and acting new words that are related to the physical activity in the class. In the non-integrated group, the children get the same exercise intensity but not related to the learning task. In the gesturing condition, the students remained seated while acting the targeted words. Whereas in conventional conditions, the children repeated the target words continuously without any gesture or moving. Of 111 children were introduced to 14 foreign words in 4-week teaching. They were tested for their memory of words during the program, immediately after the program and weeks after the program (follow up) using free-recall and cued recall tests. Mixed 4 conditions were analyzed based on ANOVA with free-recall and cued-recall as the dependent variables. Whereas condition between subject and time of testing within-subject as the independent variables. The result confirmed the hypothesis that integrated physical exercise where the children learn the unfamiliar foreign vocabulary while performing related physical exercise (to emphasize the meaning of the word), produce the highest immediate and delayed retention performance, in other words, it produces the highest learning outcome. It revealed that the integrated condition outperformed other all other 3 conditions either during, immediately after, and six-week after the learning.

While other studies discussed the effect of physical activities toward L2 performance for beginner learner who has never immerse in the L2 learning previously, this study by Liu and colleagues[13] try to challenge the previous study by testing possible constructive effects of physical activity toward L2 learner who has already reached some level of language competence. Additionally, this research also ahead of other research in the field in terms of linguistic competence being observed which is not only discussing the word level (employing Word-Picture Verification task) but sentence level (employing semantic judgment task). 40 samples were involved and divided into two control groups and two experiment groups with equal distribution of males and females. Both of the groups have a similar level of L2 proficiency. The experiment group was assigned to spin a bicycle during the learning phase when they were given a word-picture presentation. The exercise intensity was monitored and controlled. Physical activities benefit the beginner level of L2 students in learning a set of unfamiliar vocabulary. Moreover, their performance continuously immersed in the semantic level as indicated by the result of a Semantic Judgment task. Interestingly, a temporal asymmetry between the lexical and the semantic level emerges, with the difference between the experimental and control group emerging from the 1st testing session at the lexical level but after several weeks the participant takes re-test/ delayed testing the result were higher for experiment group at the sentence processing level.

The next study by Kruger [14] is a pilot study to sixty-one young refugees joining physical education (PE) class with a modification of physical activity within the context of primary PE games with L2 learning activities in German. The study aims to analyze the short-term effects of physical activities on L2 acquisition. It involves an experiment group content-based PE lessons with an approach to L2 learning acquisition. The control group did not receive any treatment. Vocabulary, listening comprehension, and prepositions were the main indicators for pre- and post-test. The research found that the intervention group significantly performed better in vocabulary and listening comprehension compared to the control group.

A study by Padial-Ruz et al. [15] examining the relation of physical activity to teaching content in children. Similar to a previous study by Mavilidi [12], this study integrated gesture and physical activity to 88 children L2 learning. It carried out a quasi-experimental research design under three conditions; a group of children learns L2 with gestures only, a group of children learn L2 with gesture and motor activity whereas the control group was taught using traditional method without any gesture or motor intervention. The study concluded that learning L2 with gesture and combination of gesture and motor activity promotes more effective learning of L2 vocabulary. However, the highest L2 acquisition achieved in the combined condition where children learn the language together with gesture and motor activities. However, this study did not examine the long-term effect of the intervention by conducting a delay test. Thus the effect on long-term memory remains unknown.

The author has tried to limit the study on the effect of the physical activities toward L2 learning. However, out of the expectation, most of the study employs the L2 only as the media to measure the cognitive level of participants during the physical activities intervention in terms of short-term and long-term memory. Vocabulary list and L2 memorization activity were utilized as an instrument to recall cognitive function. Thus, the papers discussed mostly on the effect of various exercises toward a very basic linguistic level, in this case, is vocabulary either common vocabulary or novel vocabulary [5, 9, 10, 12]. Hence, it is unknown whether the condition of memorizing the L2 vocabulary able to lead the L2 learner to go higher in sentence creating level. One paper does discuss on the semantic level (comprehension of a sentence) but the study involves L2 learner who has a certain level of L2 proficiency, meaning that the L2 learner has been exposed to the language before and this may interfere with the semantic level of the subject [13]. Interestingly each study was taken into consideration of previous study being cited in the review, meaning that one is learning and examining other works in the same field.

The presented paper discussed in this review was incorporating various physical activities in each study namely high running exercise, team games, circuit training, gesture, and biking [5, 9-11]. The differences in learning outcomes for those different exercise types are reminded unknown. However, the trend showed that as long as the physical activities involve whole-body movement the correlation is more positive toward L2 learning. Hence, when it does involve part-body movement such as in gesturing activities on the sitting condition, the differences are significant. Students involved in whole-body activities perform significantly better for the free-recall test in all-time duration (during, immediately after) compared to those on part-body movement [12]. The question then comes to the research utilizing cycling activities as in Liu et al. and Schmidt-Kassow et al. [10, 13], isn't it similar to gesturing activities were only part of the body that is moving for spinning the bike. But the author did not discuss either explain the condition. Hence, they were categorizing cycling activity as continuous exercise during learning.

Regarding the time of testing, most of the paper divided the testing phase into three main timelines, during, immediately after and several weeks after the treatment to find the correlation of physical activities toward the learning memory either short-term memory (during and immediately after the exercise) as well as long term memory. There is no consensus result for each phase but the overall trend showed that when it does positively affect the L2 vocabulary in the short-term memory, the L2 vocabulary test reminds the same for long term memory.

Studies concluded that physical activity stimulates brain activity which improves learning [10] which in turn makes it ideal to improve learning. Additional, simultaneous physical activities positively increase the ability to memorize new vocabulary[13] for beginner L2 learners. In contrast, to study by Liu [13] Study by Schmidt-Kassow and colleagues [10], Winter and colleagues [9] and the remaining study were given to a new learner of L2. This hinders the potential elaboration of research due to in the initial stage of learning language fluency is very limited.

In terms of gender, two out of eight studies involved men only [9, 16]. Whereas study in children found the different results of physical activities intervention toward boys versus girls in various aspects including cognitive, measurement, working memory, and fitness performance [4, 17, 18]. Thus the two reminded papers [9, 16] should take more consideration on gender proportion if they want to maintain the generalization of the data.

4 Conclusion

The present systematic literature review found evidence to suggest that there is a positive association between physical activities and L2 learning. The positive effect is quite similar to children and adults either female or male. The finding is consistently positive for short-term memory and long-term memory in terms of vocabulary acquisition. Research that determining the integration of L2 in PA as a whole-body movement versus part-body movement tends to show a more positive result in L2 performance for the whole-body intervention. The physical activities employ for the studies are quite varied in terms of the time, activity, frequency, and amount. Thus, there is no standard of physical activities to enhance L2 performance. Hence, most of the research in the field focused on the very basic vocabulary acquisition, very limited has discussed the influence of PA in a deeper aspect of language acquisition such as listening, speaking, or writing. To the best of knowledge, the highest level being examined was in the semantic judgment. Based on the provided evidence, the author concluded that integrating physical activities in L2 learning bring a positive effect on cognition of L2 vocabulary, however, more research needs to be conducted to test the effect of physical activities toward other aspects of L2 learning such as listening and reading comprehension.

References

- [1] Padulo J, Bragazzi NL, De Giorgio A, Grgantov Z, Prato S, Ardigo LP. The Effect of Physical Activity on Cognitive Performance in an Italian Elementary School: Insights From a Pilot Study Using Structural Equation Modeling. *Frontiers in Physiology*. 2019;10:202.
- [2] Doherty A, Forés Miravalles A. Physical Activity and Cognition: Inseparable in the Classroom. *Frontiers in Education*. 2019;4:105.

- [3] Mandolesi L, Polverino A, Montuori S, Foti F, Ferraioli G, Sorrentino P, et al. Effects of Physical Exercise on Cognitive Functioning and Wellbeing: Biological and Psychological Benefits. *Front Psychol.* 2018;9:509-.
- [4] Hillman ESDMRSLBRRDMMBPKECH. The sexual dimorphic association of cardiorespiratory fitness to working memory in children. *Developmental Science.* 2015;19(1):90-108.
- [5] Pesce C, Crova C, Cereatti L, Casella R, Bellucci M. Physical activity and mental performance in preadolescents: Effects of acute exercise on free-recall memory. *Mental Health and Physical Activity.* 2009;2(1):16-22.
- [6] Moher D, Liberati A, Tetzlaff J, Altman DG, The PG. Preferred Reporting Items for Systematic Reviews and Meta-Analyses: The PRISMA Statement. *PLOS Medicine.* 2009;6(7):e1000097.
- [7] Khan KS, Kunz R, Kleijnen J, Antes G. Five steps to conducting a systematic review. *J R Soc Med.* 2003;96(3):118-21.
- [8] Wahono R. A Systematic Literature Review of Software Defect Prediction: Research Trends, Datasets, Methods and Frameworks. *Journal of Software Engineering.* 2015;1.
- [9] Winter B, Breitenstein C, Mooren FC, Voelker K, Fobker M, Lechtermann A, et al. High impact running improves learning. *Neurobiology of Learning and Memory.* 2007;87(4):597-609.
- [10] Schmidt-Kassow M, Kulka A, Gunter TC, Rothermich K, Kotz SA. Exercising during learning improves vocabulary acquisition: Behavioral and ERP evidence. *Neuroscience Letters.* 2010;482(1):40-4.
- [11] Er S. TPR in FSL Early childhood education. *Procedia - Social and Behavioral Sciences.* 2013;93:1766-8.
- [12] Mavilidi M-FO, Anthony D.; Chandler, Paul A.; Cliff, Dylan P.; and Paas, Fred. Effects of integrated physical exercises and gestures on preschool. *Education Psychology Review* 2015
- [13] Liu F, Sulpizio S, Kornpetpanee S, Job R. It takes biking to learn : Physical activity improves learning a second language. 2017:1-15.
- [14] Krüger M. Second language acquisition effects of a primary physical education intervention: A pilot study with young refugees. *PLoS One.* 2018;13(9):e0203664-e.
- [15] Padial-Ruz R, García-Molina R, Puga-González E. Effectiveness of a Motor Intervention Program on Motivation and Learning of English Vocabulary in Preschoolers: A Pilot Study. *Behav Sci (Basel).* 2019;9(8):84.
- [16] Donnelly JE, Hillman CH, Castelli D, Etnier JL, Lee S, Tomporowski P, et al. Physical Activity, Fitness, Cognitive Function, and Academic Achievement in Children: A Systematic Review. *Med Sci Sports Exerc.* 2016;48(6):1197-222.
- [17] Reed JA, Einstein G, Hahn E, Hooker SP, Gross VP, Kravitz J. Examining the impact of integrating physical activity on fluid intelligence and academic performance in an elementary school setting: a preliminary investigation. *J Phys Act Health.* 2010;7(3):343-51.
- [18] Reed JA MA, Long S, Hughey M. Examining the impact of 45 minutes of daily physical education on cognitive ability, fitness performance, and body composition of African American youth. *Journal of physical activity & health.* 2013;10(2):185-97.

The Impact of The Implementation of Gradual Run Warming Up toward The Development of The Cardio Endurance Ability

Fitri Rosdiana¹, Dikdik Zafar Sidik², Yudi Nurcahya³
 {fitrirosdiana@upi.edu¹, dikdikzafarsidik@upi.edu², udinurcahya@upi.edu³}

Universitas Pendidikan Indonesia, Bandung, Indonesia^{1,2,3}

Abstract. Warming up is a preliminary training or exercise to prepare the body for physical activities by gradually increasing the intensity (increasing the pulse). The goal of this research is to determine the impact of the implementation of gradual run warming up toward the development of the cardio endurance ability. This research is an experimental research with One-Group Pretest-Posttest design. The sample was 40 Sports college students. They were selected by purposive sampling. The research instrument to determine the cardio endurance ability was Balke Test and the data analysis technique was SPSS version 21 software. SPSS is a computer software whose function is to calculate statistical data. The results showed that the implementation of gradual run warming up could have a significant influence on the development of the cardio endurance ability.

Keywords: warming up, continuous run, cardio endurance, balke test

1 Introduction

In general, sports are very beneficial for health because they can improve the quality of one's body. Any type of training cannot be separated from the needs for good physical fitness. Physical fitness is the ability to perform daily activities with enthusiasm [1] without experiencing excessive fatigue [2] and allows the athletes to recover before doing further activities [3]. Physical fitness, physiologically, consists of anaerobic and aerobic abilities. Aerobic ability is often also called as general endurance [3]. Cardiorespiratory endurance is the ability of the circulatory system to provide and store (supply) energy during the activity so that it does not encounter fatigue [4]. Cardiorespiratory endurance is a place in which adenosine triphosphate (ATP) is re-synthesized to produce energy. This activity usually lasts longer than five minutes [5]. In sports, endurance has a very important role in every branch of sport. Before doing physical fitness activities, endurance needs to be warmed up first.

Warming up is a preliminary training prepared to improve further physical training [6]. Warming up must be specific to the physical activity that will be carried out [7, 8]. Warming up is useful for increasing body temperature, expediting blood flow, warming muscle temperature, improving muscle contraction, and increasing coordination [9]. Warming up will reduce and prevent the possibility of injury to the muscles [10].

According to [11] warming up techniques can be categorized into two: passive and active. There are three types of warming up methods, namely passive, general, and specific [6]. Passive warming up is a warming up that is done to increase body temperature (muscle temperature) by external manners such as taking saunas, bathing using hot water, and having massage [11, 12]. Active warming up involves physical activities that cause greater cardiovascular changes such as jogging, running, cycling, skipping, gymnastics, and others [13]. In accordance to [14] that general warming up such as jogging followed by stretching of certain muscles is included in active warming up. Specific warming up includes special movements that are part of physical activity or mimic the movements that will be carried out in the core training [8].

Traditionally, stretching has been a part of the warming up process [15]. There are three methods of stretching according to [16], namely static, dynamic, and PNF (Proprioceptive neuromuscular Facilitation). Firstly, static stretching is done slowly to achieve muscle elongation [17]. The increase of the length of the hamstring muscles when using static stretching can be maintained for up to 24 hours [18]. Static stretching involves passive stretching which is held for a long time [19]. Secondly, dynamic stretching techniques are performed by bouncing and swinging rhythmically [16]. Each stretching is maintained for 20 seconds. Furthermore, the third stretching technique, PNF, is commonly used to increase Range of Motion (ROM) and relax muscles [20]. PNF is the most difficult stretching which requires guidance since this stretching combines several techniques [16].

According to [21], stretching method consists of three. The first one is static stretching. This stretching is divided into two: active static and passive static. Active static is done by yourself statically (holding still), followed by passive static with the help of others. The second one is dynamic stretching which is carried out by moving the body parts in a rhythmic (dynamic). Meanwhile the last stretching is PNF. Some ways to conduct PNF are contraction-relaxation technique, relaxation-contraction technique, contraction-relaxation-contraction techniques, contraction-relaxation-antagonist contractions, and hold-relax-swing technique.

The purpose of warming up is to raise body temperature and performance which consists of aerobic activities with submaximal intensity, like running and cycling [22, 23, 24]. Running is an accelerated frequency of steps so that when we are running, there is a tendency for the body to float. It means that our feet do not touch the ground or at least one foot still touches the ground [25]. The warming up implemented in this research was gradual run warming up which was started at the beginning of the meeting as much as 4 rounds with a distance of 400 m track and the warming up program was increasingly improved with progress (4-4-5-5-6-6-7-7- 8-8-9-9-10-10-11-11). A lot of relevant research stated that a performance could be improved by warming up [26]. The attempt to warm up before doing the training actually has a beneficial effect on the endurance with an indicator that sweat is coming out [27]. Athletic performance according to coaches and athletes could be improved by warming up. In addition, warming up could reduce the likelihood of injury [28]. A performance could be improved by warming up regardless of the intensity of the warming up itself [29]. This research shows that completing warming up before doing the next training has been shown to improve the subsequent performance. Improvements have been seen in aerobic and anaerobic sports; one of them is running [30].

2 Methods

2.1 Subjects

The population and sample in this research were 40 Sports college students batch 2018. They were selected by purposive sampling technique. After receiving detailed explanation of the objectives, potential benefits, and risks associated with participating in this research, each student gives his written consent.

2.2 Protocol

In its implementation, researchers conducted the initial test and measurement as initial data and then gave them gradual run warming up treatment. After finishing the treatment, the final stage of the test and measurement was carried out to determine the results of the warming up program that had been given. The step taken for data collection was preparing the test instruments. The data were in the form of quantitative. The data collection schedule consisted of two stages. Those stages were a preliminary test to determine the initial conditions of the subject and a final test to see the progress of the results of the training treatment.

The method was an experimental method with one group pretest-posttest design [31]. The research instrument was gradual run warming up training program as the process in collecting the data and test items to determine the ability of cardio endurance; that was measured through the Balke Test [32].

3 Results and discussions

The data gathered from the sample in conducting pretest and posttest were analyzed by SPSS version 21 software. The analysis technique was paired sample t-test. This test was used to test whether there were differences or influences. The first step to see the impact of the implementation of gradual run warming up toward the development of the cardio endurance ability was to do a normality test though the Kolmogorov-Smirnov One-Sample Test. Because the distribution of the subjects was normal, it was then followed by a descriptive data test through Paired Samples Statistics and a correlation test though Paired Samples Correlations.

Table 1. Gradual run warming up

Component	Gradual Run Warming Up			
	Mean		Correlation	Sign
	Before	After		
Cardio Endurance Ability	13.62	12.82	.816	.000

The average value of cardio endurance ability pretest and posttest is $13.62 > 12.82$., which means that there is an average difference between pretest and posttest trainings and there is also the correlation coefficient value of cardio endurance which is 0.816 with a significance

value of 0.000. Because the Sig value <probability 0.05, it can be said that there is a relationship between pretest and the posttest variables. To prove whether the difference is really significant, then we need to interpret the results of the paired sample T test contained in Table II.

Table 2. Results of the paired sample T test

Component	Gradual Run Warming Up		
	Result	Sign.	Significance Test
Cardio Endurance Ability	Increased	.000	Significant

Based on the test table above, the Sig. (2-tailed) of the cardio endurance is 0,000 <0.05, then H₀ is rejected and H_a is accepted. Therefore, it can be concluded that there is an average difference between pretest and posttest, which means that there is an effect of the gradual run warming up toward the development of the cardio endurance.

The development can be seen in the table below.

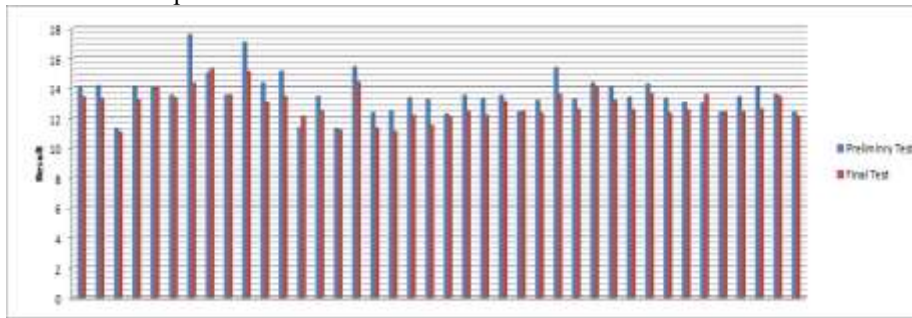

Fig. 1. Percentage of initial test and final test of the cardio endurance ability affected by the gradual run warming up

From the results above, it was found that the process of the implementation of gradual run warming up affects the development of the cardio endurance ability. The results of this research are supported by [22, 23, 24] that the warming from aerobic activities with submaximal intensity, such as running and cycling, could raise body temperature and performance. The warming up must be in line with the principle of specifications if the coaches, trainers, or even researchers want increase in the obtained results to be more effective. This is because specific warming up will affect the next physical activity that will be carried out. [7, 8] stated that the performed warming up must be specific to the physical activity to be carried out.

The results of this research indicate that the effect is not too large. This can be seen from a few samples who only experienced a slight increase because the sample has better cardio endurance quality hence their maximum ability is almost achieved. Changes in the initial test and the final test on the gradual run warming up toward the cardio endurance are in accordance with physiological principles because the increasing number of repetitions, the longer duration of doing, and the increasing distance traveled will give a better adaptation effect. In addition, the discipline factor of the sample in undergoing the provided training

program will also affect the results. [33] said that athletes who carry out training programs in a disciplined manner with intense training could get the benefit from the exercise.

4 Conclusion

Researchers have reported various results regarding the effect of warming up. In this research, it can be said that the implementation of gradual run warming up gives a significant influence toward the development of the cardio endurance ability. For further research, it is recommended that the topic of his research have to be adapted to the needs of further training. In the other words, the warming up must be specific in accordance with the sport so that the benefits of the warming up can be well-achieved because the warm up will affect the next physical activity that will be carried out. In addition, for further research, researchers suggest that it should not only be based on the distance traveled but time and intensity also need to be considered.

References

- [1] Hedrick, A. Physiological responses to warm-up. *J Strength Cond Res*, 1992. 14: 25–27
- [2] Shellock, F. G, Prentice, W. E. Warming-up and stretching for Improved physical performance and prevention of sports-related injuries. 1985. pp 267-278
- [3] Faigenbaum AD, Bellucci M, Bernieri A, et al. Acute effects of different warm-up protocols on fitness performance in children. *J Strength Cond Res*; 2005. 19 (2): 376-381
- [4] Smith, CA. The warm-up procedure: To stretch or not to stretch. A brief review. *J Orthop Sports Phys Ther* 2004. 19: 12–17.
- [5] Safran M.R, et al. The role of warmup in muscular injury prevention.(january), 1988. pp: 123-129
- [6] Bishop, D. Performance changes following active warm up and how to structure the warm up. 2003. 33 (7): 483-498
- [7] Safran MR, Seaber AV, Garrett Jr WE. Warm-up and muscular injury prevention: an update. 1989. 8 (4): 239-250
- [8] Wathen, D. Flexibility: Its place in warm up activities. *NSCA Journal*. 1987. 6:26-27
- [9] Young, W. B and Behm, D. Effect of running static stretching and practice jumps on explosive force production and jumping performance. 2003. (March)
- [10] Carolina et al. Effect of Warm-Up on the Standing Broad Jup, 2003. 17 94), pp 710-714
- [11] Yokoi, H and Campisi, P. Effect of stretching on Prevention of Injuries for Military Recruits. 2018. 168 (August 2002), pp 442-446
- [12] Woods, K, Bishop, P, and Jones, E. Warm Up and Stretching in thr Prevention of Muscular Injury, 2007. 37(12)
- [13] Volker, C et al. The Effect of Static Stretch and Warm-up Exercise on Hamstring Length Over the Course of 24 Hours. *J Orthop Sports Phys Ther* 2003;33:727-733.
- [14] Ma, J. E. B and Beaulieu, J. E. Stretching Program, 2016. 3847 (December). doi: 10.1080/00913847.1981.11711207.
- [15] Osternig LR, Robertson R, Troxel R, Hansen P. Muscle activation during proprioceptive neuromuscular facilitation (PNF) stretching techniques. *American Journal of Physical Medicine*. 1987. Oct;66(5):298-307
- [16] Sidik, D. Z et al. *Pelatihan Kondisi Fisik*. Bandung : PT Remaja Rosdakarya 2019. ISBN 978-602-446-343-4

- [17] Young W, Behm D. Should static stretching be used during a warm-up for strength and power activities? *Strength Cond* 2002. J24:33–37
- [18] Young, W. B. The use of Statistic Stretching in warm up for training and Competition, 2007, 212-216)
- [19] Behm, D and Chaouachi, A. A review of the acute effect of static and dynaic streching on performance, 2011. doi : 10.1007/s00421-011-1879-2.
- [20] Djumidar,A. W. M. Belajar Berlatih Gerak-Gerak Dasar Atletik dalam Bermain. Jakarta: PT Raja Grafindo, 2004
- [21] Fradkin, AJ, Zazryn, TR, and Smoliga, JM. Effects of warming-upon physical performance: a systematic review with metaanalysis.*J Strength Cond Res* 2010, 24(1): 140–148.
- [22] Chwalbii, J. Effect of Active Warming-up on Thermoregulatory , Circulatory , and Metabolic Responses to Incremental Exercise in Endurance-Trained Athletes *, 1898, 0–4.
- [23] Grodjinovsky and Magel. *Research Quartely*. American Association for Health, Physical education and Recreation effect of warm-up running performance. (april 2015) pp 37-41.
- [24] Hajoglou, et al. Efect of warm-up on Cycle Time Trial performance. 2005. Doi:10.1249/01.mss.0000177589.02381.0a
- [25] McBride, JM, Nimphius, S, and Erickson, TM. The acute effects of heavy-load squats and loaded countermovement jumps on sprint performance. *J Strength Cond Res* 2005, 19: 893–897
- [26] Fraenkel J. R. dan Wellen, N. E. *How to Design and Evaluate Research in Education* (Second edition). United States of America: Mc-Graw Hill,inc, 1993.
- [27] Brian Mckenzine. 101 Performance Evaluation Test. 2005. ISBN: 1-905096-18-6
- [28] Iaa, F. M. and Bangsbo, J. Speed endurance training is a powerful stimulus for physiological adaptations and performance improvements of athletes. *Scandinavian Journal of Medicine and Science in Sports*, 20(SUPPL. 2), 2010, pp. 11–23. doi: 10.1111/j.1600-0838.2010.01193.x.

Development of Comprehensive General Nutrition and Nutrition Label Questionnaire

Galuh Nita Prameswari¹, Arif Rahmat Kurnia², Awalukin Arianto³, Tsaniatin Nahla⁴, Mila Aliffia⁵

{nitagisela@mail.unnes.ac.id¹, arifrk@mail.unnes.ac.id², aaawalukin@gmail.com³}

Universitas Negeri Semarang, Semarang, Indonesia^{1,2,3,4,5}

Abstract. This research to develop an instrument to measure the knowledge and habit related to general nutrition and nutrition labels with good validity and reliability. The Comprehensive General Nutrition and Nutrition Label Questionnaire (CGN2LQ) were developed in Bahasa by modifying its content to suit the latest trend in nutrition education. The questionnaire tested on 67 adolescent students (universities and high school) in Semarang, Indonesia. The Cronbach's alpha for validity and alpha value for reliability was used. There were seven section of the questionnaire with total 132 questions. The result showed that 62 questions were valid for the final version of CGN2LQ. The questionnaire were reliable. The validity by scoring consistently more than 0.2404 which is 0.241-0.909 on each section. The reliability shown high alpha ranging from 0.686 to 0.974. The CGN2LQ meets the criteria for validity and reliability. The CGN2LQ useful to understand the relationship between nutrition knowledge, nutrition labels knowledge and habit of nutrition labels use.

Keywords: nutrition labels, nutrition knowledges, nutrition label habits, nutrition labels questionnaire, nutrition knowledges questionnaire.

1 Introduction

Nutrition knowledge is something that is known about food in relation to optimal health. Nutrition knowledge includes knowledge about selection and daily consumption properly and provides all the nutrients needed for normal functioning of the body. Nutrition knowledge has an important role in determining a person's nutritional status. Good nutritional knowledge can make someone more careful so that they will have the type of food consumed better. Low knowledge of a person's nutrition is associated with poor nutritional status such as malnutrition or over nutrition. This is because people who have low nutritional knowledge tend to consume foods that are high in sugar, high in fat, high in salt, and low in fiber [1]. Various innovations have been made to improve nutritional knowledge, but nothing has been applied nationally except by the use of nutritional information labels on packaged food products [2,3].

Nutrition label is an obligation which is imposed on producers to provide nutritional product information on packaging [4,5]. The component of nutrition information label that is most often read is the label about fat information, while the least read is sodium [3]. The

gender and attitude of students are related to the behavior of reading nutrition information labels [6].

The level of education is related to the habit of reading nutrition information labels. The behavior of reading nutrition labels relates to the level of education, people who have higher education and come from urban areas tend to read nutrition information labels more often [7]. Too much information on nutrition labels can hamper understanding, when the information is sufficient, understanding and use will be better [8]. Good nutritional knowledge will make people tend to read and pay attention to nutritional information labels, so that it will affect the choice of food products purchased [9,10]. This research aimed to develop a valid and reliable questionnaire to measure nutrition knowledge, nutrition labels knowledge, and the habit of nutrition labels use.

2 Methods

This study was descriptive observational using cross sectional design. The questionnaires was developed first by combining several questionnaires and adding relevant items for improving the validity and reliability[11,12]. Data is collected using online questionnaires through Google Form and distributed via email and WA because the research location is experiencing RCA (Restricted Community Activities). The study was not included in clinical research, and no intervention was carried out on the subject. Informed Consent information and research procedures are given directly to subjects during the data collection process. Recruitment of subjects is done through WA groups, private WA, and e-mail. The data entered will never be opened to the public, and there is no possibility of further use of the personal data collected.

The number of questions contained in the questionnaire was 98 items. Quantitative data retrieval is done by using online questionnaire. Data collected are primary and secondary data. Primary data were obtained from respondents' answers from questionnaires that included sample identity, nutritional knowledge, and the use of nutritional information labels. Whereas secondary data was obtained from the Central Statistics Agency of Semarang. The research instrument used was the CGN2LQ.

The instrument validity and reliability tests were carried out on teenagers in Semarang city at least 30 people. So that the questionnaire was truly understood by the research subjects and could measure what would be measured (valid) and provide consistent (reliable) results.

3 Results and discussions

In Table 1 it can be seen that the age of respondents is mostly 19 years (64.2%). And most of them are female respondents (85.1%). Most respondents have a higher education background (86.6%). More than half of the respondents (55.2%) are currently undergoing nutrition education. And there is one respondent who smokes (1.5%)

Government Regulation Number 69 of 1999 concerning Food Labels and Advertising states that the inclusion of nutritional content on labels must be done for packaged food accompanied by a statement that food contains vitamins, minerals and other nutrients added and food required under statutory regulations [13]. This food labeling aims to provide true and

clear information to the public about packaged food products before buying or consuming them [14].

Many factors play a role in influencing someone to use food labels, including nutrition education [15]. Someone who has healthy eating habits is also more likely to use nutritional value information [15].

Based on the results of research [16] nutrients that are often the attention of respondents in reading information on the nutritional value of packaged foods are 49.5% fat, 41.5% saturated fat, and only 24.1% who pay attention to sodium content. Respondents with an average age of > 20 years will pay more attention to the nutritional content of protein, vitamins, fat and sugar on the packaging and never or rarely pay attention to the content of sodium, dietary fiber, and cholesterol [13]. As for the reasons of respondents who do not read the label most packaged food product nutrition states do not understand or understand, not enough time to read and do not feel important [16]. The percentage of men is less concerned with food labels [16].

Table 1. Characteristics of the respondents

Characteristics	Parameter	N=67	%
Age	16	3	4.5
	17	5	7.5
	18	16	23.9
	19	43	64.2
Gender	Boy	10	14.9
	Girl	57	85.1
Education	High School	9	13.4
	University	58	86.6
Nutrition's study	Yes	37	55.2
	No	30	44.8
Smoking	Yes	1	1.5
	No	66	98.5

There were seven section of the questionnaire with total 132 questions. The result showed that 62 questions were valid for the final version of CGN2LQ, and this questionnaire were reliable. The validity by scoring consistently more than 0.2404 (r table for 67 samples) which is 0.241-0.909 on each section. The reliability shown high alpha ranging from 0.686 to 0.974.

Table 2. Results of comprehensive validity and reliability tests of General Nutrition and Nutrition Label Questionnaire (CGN2LQ) (r table in 67 samples are 0.2404)

CGN2LQ	Part Names	Correlation coefficient value	Reliability value
Section 1	Nutrition Advice	0.390-0.495	0.703
Section 2	Food Classification	0.262-0.477	0.716
Section 3	Food Choice	0.280-0.714	0.686
Section 4	Nutrition and Diseases	0.280-0.714	0.686
Section 5	Nutrition Label Knowledge	0.241-0.700	0.815
Section 6	Nutrition Label Use	0.604-0.909	0.974
Section 7	Nutrition Label Habits	0.491-0.610	0.774

The validity and reliability of the questionnaires is pretty good. The questionnaire itself run into some robust editing process. The 132 questions from the first version of the CGN2LQ is only divided into two sections, a nutrition knowledge section and a nutrition label section. The researcher found the questioner was too much, so it decided to divide it into smaller sections. After doing discussion with adolescents in Department of Nutrition, it was decided to divide the section into 7 which were nutrition advice, food classification, food choice, nutrition and diseases, nutrition label knowledge, nutrition label use, and nutrition label habits. The questionnaires then made into google form versions, which then distributed to the students both in high schools and universities. From 67 respondents, we conduct validity and reliability tests. These tests proved that some questions were invalids, so we decided to put down those invalid questions. There are a number of items that are invalid questions, including questions that answer respondents' answers that are almost the same (similar), so that the validity is low. For example, questions related to consumption of sweet foods (containing added sugar), show the results that almost all respondents stated that consumption of sweet foods and drinks (containing added sugar) must be limited. Questions related to foods and beverages that are usually low in added sugar are natural yogurt, most respondents also stated a similar answer to the question item that ice cream contains a lot of added sugar, most respondents also stated the same answer when responding to questions about canned foods containing high salt. Some items that get answers almost all the same question related to oats containing high fiber, most respondents also answered correctly that poultry such as chicken, duck, turkey, are good food sources of protein, including beans as a source of protein. Likewise with food sources of carbohydrates, all respondents stated that potatoes or tubers are a good source of carbohydrates. In the related section of diseases related to nutritional intake, several questions that almost all respondents answered were similar namely that diseases related to low intake fiber in food is a large intestine disorder, it is possible that some of the questions they have got in the material provided at school are related to the nutrient content in food and some diseases related to food intake. Many question items with true or false answer types, show invalid results. There are also several question items that are related to the same thing but with different question item numbers with different sentences. Furthermore, the question items that were invalid were excluded from the questionnaire, because they were already represented by other question items with the same material topic even with different sentences. At the end there were 62 valid and reliable questions which divided into 7 sections.

The reliability test is ranging from 0.686 to 0.974. The validity itself made this questionnaire is good to be used as tools in measuring knowledge and habits in nutrition

knowledges and nutrition habits. This questionnaire is important tool in measuring nutrition label knowledge and habit. Those two were important factors in enabling the use of nutrition label in later stage of life [13]. Nutrition label is prominence in improving awareness about the food quality. Good nutrition label will be understandable across multiple circumstances ranging from different economic status, different educational background, and even in the different geographical areas[7]. The impact alone is far greater than another education tools such as poster, leaflet, pamphlet, or booklet, because nutrition label is arbitrary in all processed foods[14]. So, the role it plays is very important one.

4 Conclusion

This research demonstrated that the CGN2LQ meets the criteria for validity and reliability. It should be useful to understand the relationship between nutrition knowledge, nutrition labels knowledge and habit of nutrition labels use.

Acknowledgements

This research is funded by Dana PNBIP DIPA FIK UNNES 2020. Author declares that there is no conflict of interest regarding the publication of this articles.

References

- [1] Sartika RAD. Pengaruh Pendidikan Gizi terhadap Pengetahuan dan Perilaku Konsumsi Serat pada Siswa. *J Ilmu Pendidik*. 2011;17(4):322–30.
- [2] Wulandari M, Prameswari GN. Media Komik terhadap Peningkatan Pengetahuan dan Sikap Gizi pada Anak yang Gemuk dan Obesitas. *J Health Edu*. 2017;2(1):73–9.
- [3] Sudahono N, Indrawani YM. Gambaran Perilaku Membaca Label Pangan Dan Reguler Fakultas Kesehatan Masyarakat Universitas Indonesia Angkatan 2013. Universitas Indonesia; 2014.
- [4] Kustantinah. Peraturan Kepala Badan Pengawas Obat dan Makanan Republik Indonesia tentang Pengawasan Klaim dalam Label dan Iklan Pangan Olahan. Jakarta: Badan Pengawas Obat dan Makanan; 2011 p. 1–46.
- [5] Kementerian Kesehatan RI. Pedoman Gizi Seimbang (Pedoman Teknis Bagi Petugas dalam Memberikan Penyuluhan Gizi Seimbang). Direktorat Jenderal Bina Gizi dan Kesehatan Ibu dan Anak, editor. Jakarta: Kementerian Kesehatan RI; 2014. 129 p.
- [6] Sinaga C, Simanungkalit SF. Faktor-Faktor yang Berhubungan dengan Perilaku Membaca Label Informasi Gizi. *J Endur*. 2019;4(1):192.
- [7] Mandle J, Tugendhaft A, Michalow J, Hofman K. Nutrition labelling: A review of research on consumer and industry response in the global South. *Glob Health Action*. 2015;8(1):1–10.
- [8] Nørgaard MK, Brunso K. Families' use of nutritional information on food labels. *Food Qual Prefer* [Internet]. 2009;20(8):597–606. Available from: <http://dx.doi.org/10.1016/j.foodqual.2009.07.005>
- [9] Brunner TA, van der Horst K, Siegrist M. Convenience food products. Drivers for consumption. *Appetite* [Internet]. 2010 Dec;55(3):498–506. Available from: <http://dx.doi.org/10.1016/j.appet.2010.08.017>
- [10] Kakinami L, Houle-Johnson S, McGrath JJ. Parental Nutrition Knowledge Rather Than Nutrition Label Use Is Associated With Adiposity in Children. *J Nutr Educ Behav*. 2016;48(7):461–467.e1.
- [11] Kliemann N, Wardle J, Johnson F, Croker H. Reliability and validity of a revised version of the General Nutrition Knowledge Questionnaire. *Eur J Clin Nutr*. 2016;70(10):1174–80.

- [12] Alsaddah AS. How Does Knowledge and Utilization of Nutrition Labels. Kent State University; 2014.
- [13] Cassady DL. Food Label Knowledge. *Appetite*. 2015;207–16.
- [14] BPOM. Pengawasan Klaim dalam Label dan Iklan Pangan Olahan. Jakarta, Indonesia; 2011. n food label use. *A Rev Lit*. 2015;92:207–16.
- [15] Campos S, Doxey J, Hammond D. Nutrition labels on pre-packaged foods: A systematic review. *Public Heal Nutr*. 2011;14:1496–506.
- [16] Castillo L, Moya. Information search behaviour, understanding and use of nutrition labeling by residents of Madrid, Spain. *J Public Heal*. 2015;129(3):226–36.

Integrating Leadership into Futsal Training Program for Positive Youth Development

Gemi Candra¹, Ruli Saepul Hayat², Amung Ma'mun³, Nuryadi⁴
 {gemicandra.gc@gmail.com¹, rullysaepulhayat7@upi.edu², amung@upi.edu}

Universitas Pendidikan Indonesia, Bandung, Indonesia^{1,2,3,4}

Abstract. This study aims to determine the difference in leadership development among a group of futsal players that was integrated with leadership and not. The research used a quasi-experimental research method with The Matching-Only Pretest-Posttest Control Group Design. Samples were taken using purposive sampling technique which was divided into three groups. Analysis of the effect of leadership treatment into the futsal training program was carried out with one way ANOVA and further tests with Scheffe and the t test. Based on the results of data processing and analysing, there was the effect of development in the group that were integrated with leadership as much 98.78. Analysis of the effect of leadership treatment was done by Gain Score. The result of leadership treatment effect analysis was the group that was integrated with leadership gave the effect towards leadership development as much 77,18% that was included in effective category.

Keywords: integrating, leadership, positive youth development, futsal

1 Introduction

It has been studied that global economic activity will be in a strict competition. more than that, it also has been stated that global economy will always change follows the era. as the result, it will provide challenges for young people to learn more in order to improve their abilities and life skills. furthermore, young people have been demanded to master some abilities and also developed life skills as a provisons in a real competition in the future [1]. Related to the statement before, L. D. Cronin & Allen, (2016) stated that life skills are the skills needed to face the demands and challenges found in daily life [2]. In addition to the skills aspect, life skills also include other physical aspects such as healthy eating patterns, aspects of knowledge (cognitive) that includes self-talk, and also behavior that includes goal setting [3].

Leadership as one of the life skills contained in sports becomes one of the basic aspects of sport, especially in team sports performance, although basically leadership also applies in various fields and contexts [4]. Leadership plays a role in motivating and encouraging team members to maximize the potential contained in the team, by being able to influence the confidence of team members, athlete leaders hold the key to optimal team performance [5]. The role, strategy, and tactics of a leader is very influential on the achievement that will be

obtained by a group, but the role of each group member still cannot be eliminated [6]. The leader must not only develop the environment, but also relate directly to psychological and social aspects that have a direct effect on motivation.

Leadership has great significance in creating high performance and building team loyalty in sports. Every team or group of the most talented players will not always win sports games. In other words, talent is not decisive in a sports game. What is considered more important than talent is better than the players needed as a whole team. For this reason, an optimal process is needed [7]. Thus, everything related to leadership produces the final results that will be obtained, for example regarding the choice of leadership style, the better the leadership system, the better the results will be obtained. This is evidenced by various studies which state the significant importance in sports and leadership [8]. Some leadership is one part of life skills that are against sports, as well as it is against life. Hardcastle et al (2015) suggested that youth sports programs have a positive impact on the development of young people by helping them learn about themselves and to develop life skills [9].

Starting from a number of previous studies stated that learning life skills; in this case leadership skills can be included in sports teaching programs that are centered on specific sports skills. However, it has been suggested for programmers to be more serious about life skills learning by compiling specifically sports programs that teach life skills, so that even youth development can be encouraged. One of the goals of sports learning is also achieved, namely the application of values contained in sports into life daily [11].

The last few decades sport has become a means of positive youth development (PYD) [12]. In other words, the development of Youth in good terms has become the ultimate goal that is expected to be achieved through sports. As has been stated by Hold (2016) that sports have been arranged in such a way as to be able to foster positive youth development (PYD). Researchers in the field of sports psychology have worked hard to better understand how sport can be used as a medium to encourage positive youth development [13]. In the research conducted by Yoshitaka Iwasaki (2015) it was further discussed that there are three core concepts related to positive youth development (PYD). The three concepts are stated as follows, firstly the empowerment approach is based on strength in order to engage youth, secondly the development of capacity or skills and positive outcomes (in accordance with what is desired) for youth and institutions that serve youth, and finally the youth-oriented research process and collaborative nature that is expected to help this positive outcome [14].

Based on the theories stated earlier, positive youth development (PYD) can be stated to revolve around various development competencies needed by youth for personal, social and system needs to be able to become productive and contributing members of society [15]. Furthermore, positive youth development (PYD) pays special attention to the physical, personal, social, emotional, intellectual and spiritual development of youth, and emphasizes youth's strengths, resources and potential. On the other hand, positive youth development (PYD) is not only considered as the end result of a change process, but also as a strength-based approach used to explore youth development, in this case youth is seen as a resource that will be developed not a problem that is a solution must be found [16].

Leadership as one of life skills contained in sports has become one of the basic aspects of sports, especially in team sports performance, although, basically leadership also applies in various fields and contexts [17]. Leadership is expressed as a result of combining skills and knowledge in a group of people with specific goals and motivating individuals to achieve certain goals. The role, strategy, and tactics of a leader is very influential on the achievement

that will be obtained by a group, but the role of each group member still can not be ignored [18].

There are many sources stated the role of sports as an introduction for someone to achieve good goals, namely life skills. where, one of those skills is leadership. Life skills have been interpreted broadly as a skill needed in dealing with the demands and challenges in daily life [19]. Therefore, sport has been considered as a means that can support youth development in good terms [20]. A perception that attached to this definition is the skills learned in sports are considered as life skills, so it must be transferred and applied in daily life [21].

Sport has been identified as an effective intermediary for learning life skills. Many researchers (e.g. Bean & Forneris, 2016; Camiré & Kendellen, 2016; Turnnidge, Côté, & Hancock, 2014) have discussed the importance of using a planned approach to youth development. As a life skill chosen in this research, it is known that the process of integrating leadership into sports requires a well-planned approach. For this reason, there are four principles that are expected to help integrating leadership into sports training program. The first principle is (a) focus on leadership in each meeting, this principle aims to maximize the leadership teaching process during the meeting. Besides, teaching leadership can be carried out with two or more meetings in order to achieve successful leadership learning. Moreover, the difficulties encountered at the first meeting can be identified then corrected at the next meeting. The second principle is (b) introducing leadership at the beginning of meeting. It must be done appropriately, where to introduce leadership it is necessary to allocate time clearly. The introduction of leadership must be combined with the introduction of skills in the game of futsal itself. Then the third principle is (c) applying strategies to teach leadership throughout the lesson. The use of strategies in teaching leadership is considered as a necessary aspect, because it can provide opportunities for group members to be able to practice the life skill through predetermined sports, where in this study the sport used is futsal. For this reason, trainers are expected to integrate two types of strategies in the learning process. The first strategy must involve a combination of leadership with activities in futsal itself. The second strategy is some specific activities that are related to leadership, for example through a group game. Then the last principle is (d) evaluating leadership at the end of the lesson. Technically, trainers must provide 2 up to 5 minutes at the end of the learning process to evaluate leadership. The evaluation meant is an explanation of the application of leadership as the life skill that have been learned through futsal into daily life. In addition, the evaluation can also be carried out by giving brief questions about what has been learned as a reflection and reinforcement of the relationship between sports and life. Furthermore, in order to get a clear picture and to make it easier in applying the life skill (leadership) into daily activities, trainers should provide a concrete example of how leadership can be applied into daily situations [22].

Starting from a number of previous studies stated that learning life skills; in this case learning leadership skills can be contained in sports teaching programs that are centered on certain sports skills [23]. However, it has been suggested for teachers to be more serious about learning life skills by specifically developing sports programs that teach life skills, so that youth development can be encouraged [24], moreover, one of the goals of sports learning is achieved, namely the application of values contained in sports into daily life.

However, there is only a few research that explain how the process of transferring life skills in sports to be applied into any fields. in this case, there are two approaches revealed that can be used, the first is an implicit approach, where life skills are suggested to be taught through sports programs that focus on specific sports skills. the assumption that when learning special sports skills, an athlete can basically learn other skills implicitly which can then be

useful in any fields. The second approach is an explicit approach which suggests that life skills must be taught systematically with leadership programs. The program in question is a sports program that is well designed to provide specific guidance on how life skills can actually be transferred to daily life, where in fact that life skills are currently only taught at the beginning, middle, or end of the learning process, which means the program is not well designed [25].

Cronin & Allen, (2017) stated "some research shows that through sports, young people develop such as teamwork, goal setting, time management, emotional skills, communication, social skills, leadership, problem solving and decision making". The lack of research on the impact of leadership skills on sports makes researchers interested in examining more closely related leadership abilities. Therefore, researchers will conduct research on the theme of leadership integration into the futsal training program for Positive Youth Development (PYD) [26].

2 Methods

This type of research is quasi-experimental (Quasi Experiment Design). The research design used is the design of The Matching-Only Pretest-Posttest Control Group Design. The population in this study were members of futsal SMAN 16 Bandung and then members of Futsal SMA National and Bandung National High School students. The sample in this study was taken from the population that must be representative (represent). Sampling is based on a purposive sampling technique, taking into account age. For this reason, adolescents aged 12-25 years were selected as samples.

In this study, research data were obtained using the Identity Leadership Inventory (ILI) questionnaire which was developed by NK Steffens et al (2014). The ILI questionnaire instrument consisted of 16 statement items containing leadership skills. The measurement scale used for this research instrument is a Likert scale with a seven-point scale range from 1 (not at all) to 7 (very much). Before using the instrument the researchers tested the validity and reliability using SPSS version 20. With the results of the validity test using the $r_{count} > r_{table}$ (0.404). Likewise, the reliability test results using the Cronbach's alpha value of the result $\alpha = 0.361$ with a reliable decision.

Data processing in this study used quantitative methods with descriptive and inferential statistics. To analyze descriptive statistical data using statistical software assistance, namely SPSS version 20. Statistical prerequisite tests include normality and homogeneity tests using SPSS version 20. Analysis of the effect of leadership treatment into futsal training programs is carried out with one way ANOVA and further tests with Scheffe and the test t (independent sample t test). Meanwhile, to determine the effectiveness of the use of a method or treatment in this study using the Gain score test.

3 Results and discussions

This research consisted of three groups as the sample which is divided as follows, group A is a group of futsal players who were integrated with leadership model, Group B is a group

of futsal players who were not integrated with leadership model, and Group C is a group that did not participate in futsal altogether and were not integrated with leadership model, Where the Data obtained from each group before the treatment (pretest) and after treatment (posttest) perform as follows.

Table 1. Descriptive statistics of research results

Research Group		N	Average
A	Pretest	27	53.93
	Posttest	27	98.78
B	Pretest	24	37.96
	Posttest	24	37.96
C	Pretest	20	25.10
	Posttest	20	25.30

Based on Table 1, it was known that the average pretest score of group A was 53.93 and its average posttest score was 98.78, while the average pretest score of Group B was 37.96 and its average posttest score was 37.96, and then the average pretest score of Group C 25.10 and its average posttest score was 25.30.

After the prerequisite test was fulfilled, the hypothesis test was then conducted. The first hypothesis test in this research used the One Way Anova test while the second, third, and fourth hypothesis test used the t test, namely the independent sample t test. All of the tests used SPSS ver. 20.

Table 2. One Way Anova Test Results

Leadership Measurement					
	Sum of Squares	df	Mean Square	F	Sig.
Between Groups	75905.893	2	37952.947	4908.098	.000
Within Groups	525.825	68	7.733		
Total	76431.718	70			

It showed that $\text{sig } 0.000 < 0.005$, it declared there was a difference, then H_0 was rejected. It meant that there were differences in the leadership development of each group.

To see the similarity in the average results of leadership abilities in each group, the output of "Uji Scheffe.a.b" was used.

Table 3. Hasil uji Scheffe^{a,b}**Penilaian Kepemimpinan**Scheffe^{a,b}

Kelompok	N	Subset for alpha = 0.05		
		1	2	3
Tidak Ikut Olahraga dan tidak diberi Integrasi Kepemimpinan	19	22.58		
Ikut Olahraga tanpa Integrasi Kepemimpinan	23		34.96	
Ikut Olahraga diintegrasikan Kepemimpinan	26			94.50
Sig.		1.000	1.000	1.000

Means for groups in homogeneous subsets are displayed.

a. Uses Harmonic Mean Sample Size = 22.293.

b. The group sizes are unequal. The harmonic mean of the group sizes is used. Type I error levels are not guaranteed.

Based on Table 3, it showed that at the significance level $\alpha = 0.05$ the average coefficient of each group was in a different column. Statistically, it meant that there was a difference in the average ability of the leadership of each group.

The average coefficient that was greater than the average coefficient of the other groups was the group that participated in sport and was also integrated with leadership model, the average score was 98.78. It showed that the ability of leadership in the group of futsal players who were integrated with leadership model was better than the other groups.

Furthermore, As for knowing the difference in leadership development between the group of futsal players who were integrated with leadership model and the group of futsal players who were not integrated with leadership model can be seen in Table 4.

Table 4. The results of independent sample t test for group A and group B

		Independent Samples Test								
		Levene's Test for Equality of Variances		t-test for Equality of Means						
		F	Sig.	t	df	Sig. (2-tailed)	Mean Difference	Std. Error Difference	95% Confidence Interval of the Difference	
									Lower	Upper
Leadership Measurement	Equal variances assumed	3.404	.071	72.377	48	.000	60.819	.848	59.131	62.508
	Equal variances not assumed			74.091	45.481	.000	60.819	.821	59.167	62.472

Based on Table 4, it was known that the Sig (2-tailed) value was $0,000 < 0,05$, then it can be stated that there was a difference, which meant H1 was accepted and H0 was rejected. This meant that there were differences in leadership abilities between those who participate in sport and were integrated with leadership model and those who participated in sport, but were not integrated with leadership model.

Furthermore, the third hypothesis test was conducted to find out whether there are differences in leadership development between the group of futsal players who were integrated with leadership model and the group that did not participate in futsal altogether and were not integrated with leadership model. The result can be seen in Table 5.

Table 5. The results of independent sample t test group A and group C

		Independent Samples Test								
		Levene's Test for Equality of Variances		t-test for Equality of Means						
		F	Sig.	t	df	Sig. (2-tailed)	Mean Difference	Std. Error Difference	95% Confidence Interval of the Difference	
									Lower	Upper
Leadership Measurement	Equal variances assumed	3,294	,076	83,240	48	,000	73,478	,683	71,708	75,256
	Equal variances not assumed			89,241	43,627	,000	73,478	,629	71,818	75,138

Based on Table 5, it was known that Sig (2-tailed) value was $0.000 < 0.05$, where it can be stated that there was a difference. Therefore, H1 was accepted and H0 was rejected. This meant that there were differences in leadership abilities between those who participated in sport and were integrated with leadership model and those who did not participate in sport and were not integrated with leadership model.

Furthermore, The fourth hypothesis test was conducted to find out whether there are differences in leadership development between the group of futsal players who were not integrated with leadership model and the group that did not participate in futsal altogether and were not integrated with leadership model. The result can be seen in Table 6.

Table 6. The results of independent sample t test for group B and group C

		Independent Samples Test								
		Levene's Test for Equality of Variances		t-test for Equality of Means						
		F	Sig.	t	df	Sig. (2-tailed)	Mean Difference	Std. Error Difference	95% Confidence Interval of the Difference	
									Lower	Upper
Leadership Measurement	Equal variances assumed	,900	,990	18,735	42	,000	12,658	,676	11,298	14,022
	Equal variances not assumed			18,878	41,544	,000	12,658	,671	11,308	14,012

Based on Table 6, it was known that the Sig (2-tailed) value was $0,000 < 0.05$, then it can be stated that there was a difference, where H1 was accepted and H0 was rejected. This meant that there were differences in leadership abilities between those who participated in sport without any integration of leadership model and those who did not participate in sport and also were not integrated with leadership model.

In addition, Gain score test was carried out to determine the effectiveness of a method or treatment used in this research. The result can be seen in Table 7.

Table 7. Gain score test results

	Kelompok A		Kelompok B		Kelompok C	
	Gain Score (%)		Gain Score (%)		Gain Score (%)	
Average	77,1854	Average	-0,0014	Average	0,1841	
minimum	64,91	minimum	-2,78	minimum	-5,81	
Maximum	88,33	Maximum	2,82	Maximum	6,74	

Based on Table 7, it showed that the average Gain Score for the group that participated in sport and was integrated with leadership model was 77,1854%, where the minimum Gain Score was 64.91% and the maximum of 88.33%. therefore, it can be stated effective.

Furthermore, the average Gain Score for the group that participated in sport and was not integrated with leadership model was - 0,0014%, where the minimum Gain Score was -2,78% and the maximum was 2,82%, so it can be stated as ineffective. Meanwhile, the average Gain Score for those who did not participate in sport and were not integrated with leadership model was 0,1841%, where the minimum N-Gain Score was -5,81% and the maximum was 6,74%. it was also stated as ineffective.

Therefore, it can be concluded that those who participated in sport and were integrated with leadership model based on the data from self-assessment are effective for enhancing leadership abilities, while those who participated in sport without any leadership model integration, and those who did not participate in sport and were also not integrated with leadership model were not effective in increasing leadership abilities.

Hypothesis test results indicated that there are differences in leadership development in each group (Table 2). The HSD tukey test (Table 3) showed that the leadership abilities of the group that participated in futsal training and was integrated with leadership model were better than the other groups. The difference between the two can be seen in Table 3 shows that leadership development that follows integrated sports leadership is better than groups that is without integrated leadership. The results found are in accordance with the statement made by Gould & Carson (2008) which stated that sport can be used to improve life skills and positive youth development. the Futsal players who participated in leadership programs treated can improve their leadership skills, more than that the existence of leadership training can be considered as an effective model for leadership learning [27].

Leadership for students who participate in futsal training activities can be considered as a very beneficial skill for them for living in the community, because leadership as a result of the combination of skills and knowledge in a group of people with specific goals and expected to motivate individuals to achieve goals. Leadership can be integrated into futsal training programs, because sport is one of the most popular recreational activities for young people. Hardcastle et al (2015) suggested that youth sports programs have a positive impact on the development of young people by helping them to learn as to themselves and to develop life skills [28].

The leadership development of futsal players that given a treatment and those who were not given any treatment, can be seen in Table 4. the leadership abilities of Each group were different. The data showed that the development of leadership abilities in the group that given a treatment is greater than those who were not given any treatment. it is because of the leadership of futsal players that given treatment is systematically and deliberately arranged, so that at every meeting there is always integration of leadership programs. The result of this research is equal to the result of a research conducted by Bean & Forneris (2015) that a deliberately structured programs have better results compared to unstructured and unintentional programs [29].

The leadership development of futsal players that integrated with leadership model, and those who did not participated in futsal training and were not given any treatment, can be seen in Table 5. There was a difference between the leadership abilities of those who were given a treatment compare to those who did not participated in futsal training and were not given any treatment.

The above statement is supported by the statement of Bakoban & Aljarallah (2015) which states that "the various experiences gained from following extracurricular activities are able to have a positive impact on students' emotional, intellectual, social and interpersonal development". So interacting and working with others can have a positive impact such as leadership abilities [30].

The leadership development of futsal players that were not given any treatment and those who did not participated in futsal training and were not given any treatment, can be seen in Table 6. There was a difference of leadership ability in those two group. The data showed that the leadership development in the firstly mentioned group was slightly higher than the other group. The result is equal to what was stated by (Turnnidge, Côté, & Hancock 2014), regarding the implicit approach, where life skills are taught through sport programs that focus on specific sport skills. The assumption that when learning specific sport skills, an athlete basically can also learn other skills implicitly, it is related to the leadership abilities of futsal players that were not given any treatment still increased compare to the group that did not participated in futsal training and were not given any treatment [31].

For the final step, the researcher conducted gain score test to determine the effectiveness in the usage of a method or treatment in this research, it can be seen in Table 7 where it showed that the average score of the gain score for the leadership of futsal players that given a treatment is 77,1854% where it can be included into the "effective" category.

Thus, it can be concluded that the leadership of futsal players that given a treatment is effective to improve leadership abilities, while the leadership of futsal futsal players that were not given any treatment and those who did not participate in sport and were also not given any treatment stated as ineffective in developing leadership abilities.

This research shows that the importance of teachers or trainers to integrate the program systematically and deliberately in sports, and they are expected to not just focused on the technique, so that the results obtained are achieved well and can help develop their abilities.

4 Conclusions

The results of data processing and analyzing shows the differences in the leadership development of futsal players through futsal activities. Therefore, it can be concluded that the leadership development of futsal players that integrated with leadership program is better compared to the leadership development of futsal players that were not integrated with leadership programs and those who did not participate in futsal and were not integrated with leadership program . This leadership development can be implemented in daily life other than sport context and also can provide opportunities to experience positive youth development process.

Considering the importance of the content raised in this research, but there are still limitations in, then it is expected that there will be other researchers who can conducted a research to complete this research in the future. For further researchers, this research is expected to be a reference, so that it can be developed with enlarged variables and problems.

Acknowledgments

With the completion of this research, the author would like to thank Dr. Amung Ma'mun, M.Pd as the main supervisor and Mr. Nuryadi, M.Pd as supervisor.

References

- [1] Gould, D., & Carson, S. (2008). Life skills development through sport: current status and future directions. *International Review of Sport and Exercise Psychology*, 58–78.
- [2] Cronin, L. D., & Allen, J. (2016). Author Note. *Psychology of Sport & Exercise*.
- [3] Hardcastle, S. J., Tye, M., Glassey, R., & Hagger, M. S. (2015). Exploring the perceived effectiveness of a life skills development program for high-performance athletes. *Psychology of Sport & Exercise*, 16, 139–149.
- [4] Cotterill, Stewart T., & Fransen, Katrien. (2016). Athlete leadership in sport teams: Current understanding and future directions.
- [5] Fransen, Katrien, dkk. (2014). The Impact of Athlete Leaders on Team Members' Team Outcome Confidence: A Test of Mediation by Team Identification and Collective Efficacy. *The Sport Psychologist* p.2
- [6] Devecioğlu, Sebahattin.(2018). The Leadership Orientations of the Students Receiving Sports Education in Turkey. *Canadian Center of Science and Education*, 1.
- [7] Cotterill, S. (2013). *Team psychology in sports: Theory and practice*. Abingdon: Routledge.
- [8] Atan, T., Ünver, Ş., Kaplan, A., İslamoğlu, İ., & Demir, G. (2018). Comparison of leadership levels of students at the faculty of sport sciences and other faculties. *Universal Journal of Educational Research*, 6(6), 1313–1316. <https://doi.org/10.13189/ujer.2018.060622>
- [9] Hardcastle, S. J., Tye, M., Glassey, R., & Hagger, M. S. (2015). Exploring the perceived effectiveness of a life skills development program for high-performance athletes. *Psychology of sport and exercise*, 16 (P3), 139-149.
- [10] Chinkov, A. E., & Holt, N. L. (2016). Implicit Transfer of Life Skills Through Participation in Brazilian Jiu-Jitsu. *Journal of Applied Sport Psychology*, 28(2), 139–153.
- [11] Bean, C. N., Kendellen, K., Halsall, T., & Forneris, T. (2014/2015). Putting program evaluation into practice : Enhancing the Girls Just Wanna Have Fun program. *Evaluation and Program Planning*, 49, 31–40.
- [12] Holt,N.L.(2016).Positive youth development through sport (2nd ed.). London, UK: Routledge.
- [13] Chinkov, A. E., & Holt, N. L. (2016). Op.Cit
- [14] Iwasaki, Yoshitaka.2015.The role of youth engagement in positive youth development and social justice youth development for high-risk, marginalised youth. *International Journal of Adolescence and Youth*
- [15] Alicea, S., Pardo, G., Conover, K., Gopalan, G., & McKay, M. (2012). Step-up: Promoting youth mental health and development in inner-city high schools. *Clinical Social Work Journal*, 40, 175–186.
- [16] Theresa Beesley & Jessica Fraser-Thomas. 2019. Claims of positive youth development: a content analysis of mixed martial arts gyms' websites. Routledge
- [17] Cotterill, Stewart T., & Fransen, Katrien. (2016). Loc. Cit.
- [18] Devecioğlu, Sebahattin.(2018). The Leadership Orientations of the Students Receiving Sports Education in Turkey. *Canadian Center of Science and Education*, 1.
- [19] World Health Organization (1999). *Partners in life skills education: Conclusions from a United Nations inter-agency meeting*. Geneva: World Health Organization.
- [20] Jones, Martin I, & Lavallee, David (2009). Exploring perceived life skills development and participation in sport. *Qualitative Research in Sport and Exercise Vol 1 No 1*.
- [21] Gould, D., & Carson, S. (2008). Loc.Cit.
- [22] Kendellen, K., Camire, M., Bean, C. N., Forneris, T & Thompson, J. (2016). Integrating life skills into Golf Canada's youth programs: Insights into a successful research to practice partnership. *Journal of Sport Psychology in Action*, 1-13.
- [23] Chinkov, A. E., & Holt, N. L. (2016). Loc.Cit
- [24] Bean, C. N., Kendellen, K., Halsall, T., & Forneris, T. (2014/2015), Loc.Cit

- [25] Turnnidge, J., Côté, J. C., & Hancock, D. J. (2014). Positive youth development from sport to life: Explicit or implicit transfer? *Quest*, 66, 203-217 (B).
- [26] Cronin, L. D., & Allen, J. (2017). Development and initial validation of the Life skills scale for sport. *Psychology of Sport and exercise*, 28, 105-119.
- [27] Gould, D., & Carson, S. (2008). Life skills development through sport: current status and future directions. *International Review of Sport and Exercise Psychology*, 1(1), 58–78.
- [28] Hardcastle, S. J., Tye, M., Glassey, R., & Hagger, M. S. (2015). Exploring the perceived effectiveness of a life skills development program for high-performance athletes. *Psychology of sport and exercise*, 16 (P3), 139-149
- [29] Bean, C. N., Kendellen, K., Halsall, T., & Forneris, T. (2014/2015), Loc.Cit.
- [30] Bakoban, R. A., & Aljarallah, S. A (2015). Extracurricular activities and their effect on the students grade point average: Statistical study. *Educational Research and Reviews*, 10 (20), 2737-2744.
- [31] Turnnidge, J., Côté, J. C., & Hancock, D. J. (2014). Loc. Cit.

The Differences of Elementary School Students' Interest on Traditional Games and Online Games

Gustiana Mega Anggita¹, Hari Amirullah Rachman², Chang Yun-Chen³, Sugiarto⁴, Mohamad Arif Ali⁵, Cholid Chaerudin⁶, Adiska Rani Ditya Candra⁷, Fuadah Nor Wiqoyatul Milla⁸
 {mega.anggita@mail.unnes.ac.id¹, hari.rachman68@gmail.com², zoot79525@gmail.com³}

Universitas Negeri Semarang, Semarang, Indonesia¹,
 Yogyakarta State University, Sleman, Indonesia²,
 National Tsing Hua University, Hsinchu City, Taiwan³

Abstract. Children's interest is one indicator that can illustrate the popularity of the game. Nowadays, online games are developing rapidly and traditional games are getting forgotten. This study aims to find differences in elementary school students' interest in traditional games and online games. The method used is quantitative descriptive with a sample of 80 elementary school students in Semarang City. Data collection techniques using a questionnaire. Data were analyzed using t-test with SPSS 21 series. There are significant differences between elementary school students' interest towards traditional games and online games with significant value $0.000 < 0.05$. Elementary school students' interest towards traditional games is higher than online games with an average score of traditional games as much as 21.025 and an average score of online games as much as 14.663. Elementary school students' interest towards traditional games is higher than online games.

Keywords: interest, children, traditional games, online games

1 Introduction

The Era of Digitalization is marked by the increasing use of electronic devices in human life. Nowadays electronic devices, especially gadgets became the major component in human life. This is evident from the increasing number of Internet usage each year. Overall, the number of Internet users worldwide is projected to reach 3 billion people by 2015. Three years later, in 2018, an estimated 3.6 billion people on earth will access the internet at least once every month and Indonesia is the country with the 6th largest number of internet users after China, the United States, India, Brazil, and Japan [1, 2]. The development of devices now is evenly distributed in all ages including children aged 5 years and even under 5 years [3]. The widespread use of devices in children makes the development of online games more rapidly.

Play is an activity that can provide fun and relaxation for those who do it. Play is part of the children's world and are not separated from each other [4]. Through play children can explore the knowledge and skills that exist within him. Therefore play an important activity to be performed by children [5, 6]. The development of the type of game today is very diverse ranging from traditional games that involve more physical abilities to online games that are currently popular among children.

Traditional games are one form of physical activity that has community cultural values [7]. Traditional games and sports reflect different cultural expressions and create bridges between cultures for mutual understanding. Preservation and promotion of traditional games and sports provide an important and essential contribution to the world cultural heritage [8]. Traditional games are not merely games, in traditional games there are cultural elements that are strongly attached and must continue to be preserved [9]. The traditional game is a game that has elements of a culture that grow and develop in society in accordance with the rules and norms and customs inherited hereditary maintained using either a tool or without tools in play [10, 11]. Traditional games are the result of great cultural value for children in order to fantasize, recreate, be creative, exercise as well as a means of training for community life, skills, politeness and dexterity [12]. Traditional games tend to encourage children to do physical activity that is beneficial to the growth and development of the body, in addition, encourage traditional games encourage children to learn to work together and respect each other. Traditional games directly affect the psychomotor, cognitive and emotional development of children. Traditional games can influence the enjoyment of players and positively affect the overall development of children [13]. Traditional games are one of the physical activities used in teaching and learning activities, especially in physical education learning. Playing traditional games in learning encourages social interaction in learning, a competitive spirit, and friendship that occurs during game-play [14].

Online games are games that are connected through an internet-based network that is played using a computer, gadget, laptop or other device [15]. Online games are a recreational tool that is widely used by many people. For the majority of people playing online games (video games) can be a stress reliever, relaxation, social interaction, challenges and competitions, pleasure [16]. Online games are one product of advances in science and technology. Online games have evolved as gadget have expanded. Online games can be found and played on various devices such as smartphones, laptops, tablets and computers. With all the conveniences that exist in online games make people interested in trying to play it. Nowadays online games have very much demand ranging from children to adults, online games using computers provide more stimulation to play compared to other online games because of the rapid and instant gratification they provide [6]. The positive impact of online games is that they are able to develop people's visual-spatial abilities through the process of practicing processing spatial information from the monitor screen [17].

Traditional games and online games each have benefits in human life. Through physical education traditional games are still being introduced and preserved [18]. While the progress of the internet network and the many uses of gadgets make online games increasingly popular nowadays. When talking about physical activity, traditional games are important activities that should performed by children but online game also has beneficial for children's knowledge ability like processing spatial information. Previous studies have not explored data related to elementary school students' interest in traditional games and online games. This study aims to determine differences in elementary school students' interest in traditional games and online games.

2 Methods

The survey method was used in this study. A total of 80 elementary school students in Semarang were respondents in this study. The sampling technique used purposive sampling

with inclusion criteria include: 1) Have status of elementary school students; 2) 10-13 years old; 3) Willing to fill in the availability form to be a respondent and 4) Fill in the questionnaire interest in traditional games and online games. Procedures in this study include: 1) Subjects get an explanation of the background of the research, 2) Subjects get an explanation of the stages they have to do, 3) Subjects fill out an approval letter to be a research respondent, 4) Subjects get an explanation of how to fill in traditional game questionnaires and online games, 5) Subjects fill out questionnaire interest in traditional games and online games, 6) Data on traditional games and online games are processed to get the value of interest in traditional games and online games. Data collection techniques in this study is the use of questionnaires. the questionnaire used for data collection in this study were two questionnaires consisting of: 1) traditional game interest questionnaire and 2) online game interest questionnaire. Measurement questionnaire in this study uses a Likert scale. Data analysis using t-test using SPSS series 21. The significance value of $0.05 \leq p \leq 0.05$ will be considered for data interpretation with the prerequisite test before analysis.

3 Results and discussions

Playing in the learning process can provide a variety of movement experiences for children, where the experience of movement is very instrumental in the process of growth and development of children. Motion development for elementary school children is defined as the development and refinement of various basic motion skills and motion skills related to sports [11]. Through play, children can explore the abilities that exist within themselves and learn new skills. Based on the data obtained as many as 17.21% of respondents were 10 years old, 43.54% were 11 years old, 18.22% were 12 years old and 2.3% were 13 years old consisting of: 1) 9 male students and 7 female students aged 10 years old; 2) 23 male students and 21 female students aged 11 years old; 3) 9 male students and 9 female students aged 12 years old; 4) no male students and 2 female students aged 10 years old.

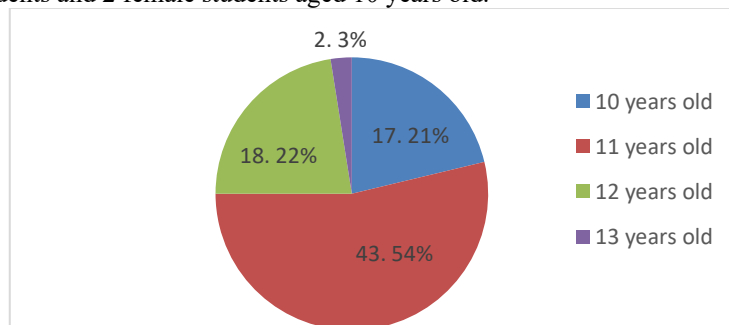

Fig. 1. Respondent's age data

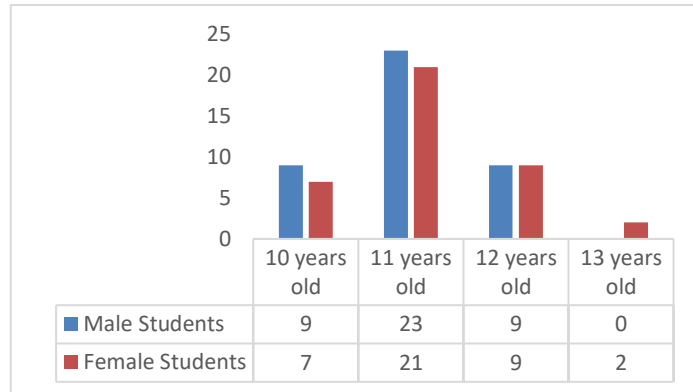

Fig. 2. Responden participation data

The development of traditional games and online games is influenced by one's interest in these types of games. The rise of gadgets uses makes online games increasingly popular among the public, including children. At present the gadget is inseparable from human life. Gadgets have become a necessity of daily life, starting from the activities of Education, Health, buying daily necessities and transportation, and have used gadgets. Technological progress is like two sides of a coin, where on the one hand technological advancements provide many positive benefits for humans to make it easier for humans to meet their needs. However, on the other hand, technological progress has a complex negative effect that exceeds the benefits of the technology itself, especially related to human life patterns in the socio-cultural dimension [18]. Interest is a form of gesture that shows enthusiasm in performing certain activities. Interest is one of the initial steps for someone to participate in certain activities. If the level of interest is high, participation in these activities will also increase. When participation increases it will have an impact on the development of traditional games and online games.

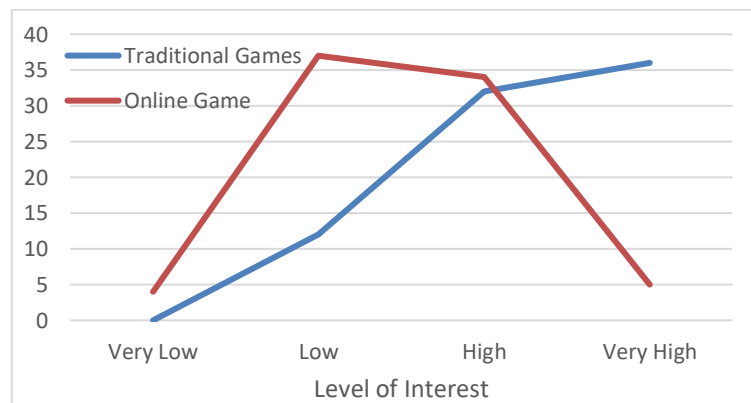

Fig. 3. elementary school students' interest towards traditional games and online games

Based on the data above it is known that elementary school students' interest in traditional games is 45% of students having very high interest, 40% of students having high interest, 15% of students having low interest and none of students having very low interest. In addition, the elementary school students' interest towards the online game as much as 6,25% of students have a very high interest, 42.5% of students have a high interest, 46.25% of students have a low interest and 5% of the students have a very low interest.

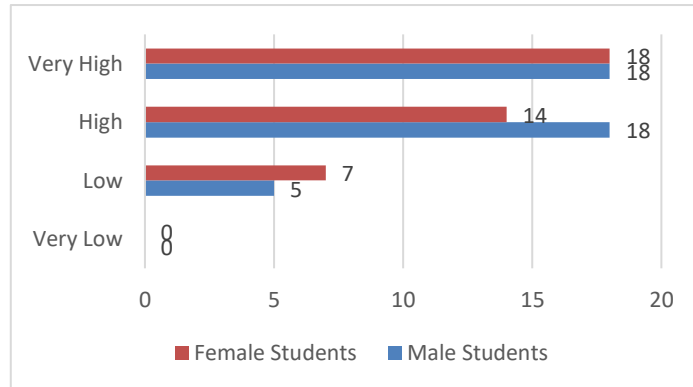

Fig. 4. Elementary School Students' interest Toward Traditional Games

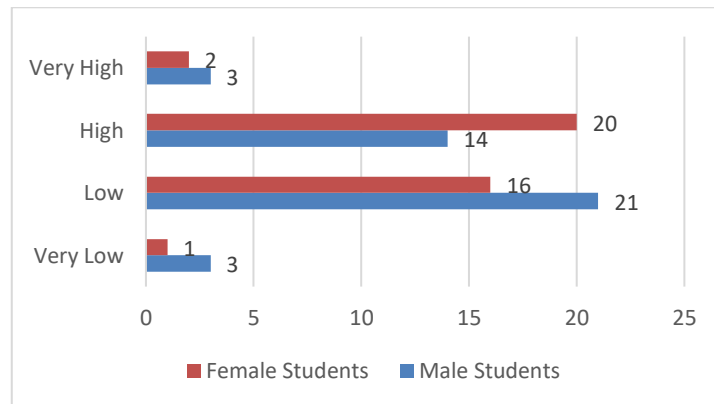

Fig. 5. Elementary School Students' interest Toward Online Games

Table 1. Difference of elementary school students' interest between traditional games and online games

Type of Game	T-test value	Sig. (2-tailed)	Mean Difference
Traditional Games	34.59	0.00	21.02
Interest	8	0	5
Online Game Interest	29.17	0.00	14.66
	9	0	3

Based on that data, there are significant differences between elementary school students' interest towards traditional games and online games with significant value $0.000 < 0.05$. Elementary school students' interest towards traditional games is higher than online games with an average score of traditional games as much as 21.025 and an average score of online games as much as 14.663. Elementary school students' interest towards the game is still higher than that of traditional online games. The development of digital devices made people begin to leave the traditional way of life. Although modernization changes the patterns of human life but in some aspects they still use traditional patterns. The inclusion of sophistication of technology brings traditional people of Indonesia to be more practical. Now the public considers traditional games or sports to be replaced by online games and fitness centers [19].

Basically traditional games and online games have a positive values on children. Traditional games involving physical activity provide benefits for the development of thinking, problem solving, basic motion development and social skills. Traditional games are facilities for children to play. Besides being beneficial for health, fitness and child development, there are also positive values contained in traditional games such as honesty, cooperation, sportsmanship, helping each others, responsibility, discipline and many more where these things can build the character of children [9, 20]. Beside the positive impact found on traditional games, the high interest on traditional games compare online game is due to inherent values of national culture. Online games are types of games that involve digital devices and internet networks. Online gaming means you can play in real time with people across the world through a computer, games console, tablet or smartphone connected to the internet. Games can offer children a world of adventure to immerse themselves in, but it's important to understand how children can stay safe and what games are appropriate for their age. There are also positive impact for children such as: 1) enhance memory, brain's speed, and concentration; 2) Improved multi-tasking skills; 3) Promotes teamwork and builds confidence; 4) physical and social benefit [21, 22].

Although both of the games has positive values on children, online game also has negative impact on children. As we know that online game not involving physical activity to performed it, children can play the game everywhere and everytime they want. It can makes children less activity and become obese. Preschool children with high intensity gadget usage have a 2.1 times greater chance of being obese compared to preschool children with low gadget usage intensity [23]. Uncontrolled gadget uses also affecting children's social and emotional, children become has negative characters such as shy, lacking confidet, lonely, stubborn and do not have good communication skills with other people [24, 25]. Therefore, every parent needs to controle and give more attention to their children if they play online game. If children play online games without under parents supervision, they become addicted to online games. To prevent children addicted to online games, parent can take some strategy such as: 1) select according to the child's age, 2) Selective choosing game applications in gadgets, 3) Accompa-

ny the child in play, 4) Limit your child's time playing gadget, and 5) Inviting children to do positive activities [26].

Based on our findings, elementary school student's interest on traditional games is still higher than online games but to face of digitalization era, precise strategies are needed in preserving traditional games and appropriate strategies are needed in supervising children from the negative effects of excessive use of gadgets and online games.

4 Conclusion

Elementary school students' interest towards traditional games is higher than online games. Both traditional games and online games have positive benefits for children's growth and development. However, playing online games for children requires more supervision from parents because there is a negative impact if children play online games without parental supervision.

The high interest of children on traditional games makes traditional games will still exist even though online games are growing rapidly. Positive values that support children's character are one of the reasons traditional games have become the choice of physical activity for children. Although online games have some negative effects, the positive benefits can be obtained by children with restrictions of gadgets use and parental supervision on duration and intensity of playing online games.

Acknowledgements

The Author would like to thank the support of Sport Science Faculty Universitas Negeri Semarang for giving grants to this research. The authors also thanks to our responden for willingness to become a research sample and participate in filling out a research questionnaire.

References

- [1] Kominfo. Pengguna Internet Indonesia Nomor Enam Dunia [Internet]. Kompas.com. 2014. Available from: https://kominfo.go.id/content/detail/4286/pengguna-internet-indonesia-nomor-enam-dunia/0/sorotan_media.
- [2] Supratman LP. Penggunaan Media Sosial oleh Digital Native. *J Ilmu Komun.* 2018;15(1):47–60.
- [3] Fajariyah SN, Suryawan A. Dampak Penggunaan Gawai Terhadap Perkembangan Anak. *Sari Pediatr.* 2018;20(2):101–105.
- [4] Maricar F, Tawari RS. NILAI DAN EKSISTENSI PERMAINAN TRADISIONAL DI TERNATE. *J ETNOHISTORI.* 2018;V(2):162–184.
- [5] Gelisli Y, Yazici E. A Study into Traditional Child Games Played In Konya Region In Terms Of Development Fields of Children. *Procedia - Soc Behav Sci* [Internet]. 2015;197(February):1859–65. Available from: <http://dx.doi.org/10.1016/j.sbspro.2015.07.247>.
- [6] Karaca S, Karakoc A, Can O, Nevin G, Gul O, Barlas U. Investigation of the Online Game Addiction Level, Sociodemographic Characteristics and Social Anxiety as Risk Factors for Online Game Addiction in Middle School Students. *Community Ment Health J* [Internet]. 2020;56(5):830–838. Available from: <https://doi.org/10.1007/s10597-019-00544-z>.
- [7] Akbari H, Abdoli B, Shafizadeh M, Khalaji H, Hajihosseini S, Ziaee V. The Effect of Traditional Games in Fundamental Motor Skill Development in 7-9 Year-Old Boys. *Iran J Pediatr.* 2009;19(2):123–129.

- [8] Boro J, Daimary R, Narzaree B. Impact of Globalisation to Traditional Games and Recreation of the Bodos. *IOSR J Humanit Soc Sci.* 2015;20(3):87–91.
- [9] Hikmah Prisia Yudiwinata HP, Handoyo P. Permainan Tradisional dalam Budaya dan Perkembangan Anak. *Paradigma.* 2014;2:1–5.
- [10] Kadek NI, Rahmadani A. Pertiwi Kabupaten Trenggalek sela- Permainan tradisional Jawa. *J Pendidik Usia Dini.* 2014;8(2):305–314.
- [11] Mega Anggita G (Universitas NS, Amirullah Rachman H (Universitas NY. PENGARUH AKTIVITAS BERMAIN DAN PERSEPTUAL MOTORIK TERHADAP KETERAMPILAN MOTORIK SISWA SEKOLAH DASAR KELAS BAWAH. *J Keolahragaan.* 2014;2(1):130–44.
- [12] Andriani T. Permainan Tradisional Dalam Membentuk Karakter Anak Usia Dini. *Sos Budaya.* 2012;9(1):121–136.
- [13] Kovacevic T, Opic S. Contribution of Traditional Games to the Quality of Students' Relations and Frequency of Students' Socialization in Primary Education. *Croat J Educ Cas Za Odgoj I Obraz.* 2014;16(1):95–112.
- [14] Trajkovic V, Malinovski T, Vasileva-stojanovska T. Traditional games in elementary school: Relationships of student ' s personality traits , motivation and experience with learning outcomes. *PLoS One.* 2018;1–15.
- [15] Haeril. Indeks Massa Tubuh Anak yang Aktif Bermain Game Online dan Anak yang Tidak Aktif Bermain Game Online. *Jendela Olahraga.* 2019;4(2):44–49.
- [16] Dumrique DO, Castillo JG. Online Gaming : Impact on the Academic Performance and Social Behavior of the Students in Polytechnic University of the Philippines Laboratory High School. In: 4th International Research Conference on Higher Education. 2018. p. 1205–1210.
- [17] Putu N, Pramesti R, Odelia A, Trisna E, Adinda H, Valeska S, et al. Sosialisasi dampak game online terhadap anak-anak. *Masy Budaya dan Inov.* 2020;1(2):69–73.
- [18] Anggita GM, Baitul S, Arif M. Eksistensi Permainan Tradisional Sebagai Warisan Budaya Bangsa. *J Sport Sci Educ.* 2018;3(2):56–59.
- [19] Ngafifi M. Advances in Technology and Patterns of Human Life in Socio-Cultural Perspective. *Kemajuan Teknol dan Pola Hidup Mns* [Internet]. 2014;2(1):33–47. Available from: <http://journal.uny.ac.id/index.php/jppfa/article/viewFile/2616/2171>.
- [20] Gede D, Arsana P. Tranformasi Budaya Dalam Permainan Tradisional Menuju Game Online. *Media Komun FPIPS.* 2016;15(2):41–45.
- [21] Parisod H, Aromaa M, Kauhanen L, Kimppa K, Laaksonen C, Leppänen V, et al. The advantages and limitations of digital games in children ' s health promotion. *Finnish J eHealth eWelfare.* 2014;6(4):164–173.
- [22] Robetson A. The Gaming Advice Hub, Get expert tips on gaming to support children [Internet]. *Internet Matters.* 2020. Available from: <https://www.internetmatters.org/resources/online-gaming-advice/>.
- [23] Tanjung FS, Huriyati E, Ismail D. Intensity of Gadget Use Among Overweight Preschool Children in Yogyakarta. *BKM J Community Med Public Heal.* 2017;33(12):603–608.
- [24] Zubaidah Z. Hubungan Durasi Penggunaan Gadget Terhadap Perkembangan Sosial Anak Pra-sekolah di TK PGRI 33 Sumurboto, Banyumanik. 2017.
- [25] Wahyuni AS, Siahaan FB, Arfa M, Alona I, Nerdy N. The Relationship between the Duration of Playing Gadget and Mental Emotional State of Elementary School Students. *Maced J Med Sci.* 2019;7(1):148–151.
- [26] Novitasari N. Strategi Pendampingan Orang Tua Terhadap Intensitas Penggunaan Gadget Pada Anak. *Indones J Early Child Islam Educ.* 2019;3(2):167–188.

The Effect of Zinc Oxide Dust and Environmental Conditions of Training Ground on Lung Forced Vital Capacity Conditions of Central Java Weightlifting Athletes

Hadi¹, Mustafa Daru Affandi², Syahru Romadhoni³
 {hadi_pabbsi@mail.unnes.ac.id¹, daru.affandi@gmail.com², syahru_fik@mail.unnes.ac.id³}

Universitas Negeri Semarang, Semarang, Indonesia^{1,2,3}

Abstract. For an athlete, training is an activity that must be done routinely. In training and competition, weightlifting requires chemicals that are used to get rid of slippery hands when lifting weights. That is Zinc Oxide. The poor condition of the training ground causes a decrease in the quality of the physiology of the lungs of the athletes. One reason is that it is sourced from Zinc Oxide dust used during training. Pulmonary physiological disorders were analyzed from Forced Volume Capacity values using a digital spirometer with standard ETS / ARS standard. The study result levels of particle dust 17, 921 mg / m³ which exceeds Threshold. From pulmonary physiology measurements, 33.33% of athletes suffer from mild restriction and decrease in pulmonary physiology caused by high levels of Zinc Oxide at the training ground.

Keywords: zinc oxide dust, pulmonary physiology, weightlifting athletes.

1 Introduction

The training center is the second home for an athlete. Where in the training center physical exercise activities are carried out, technical training to the evaluation of the exercise. Comfort in the practice room must be considered. This comfort in terms of physical conditions such as room temperature, humidity, lighting, dust cleanliness in the training room. With the comfort of a comfortable place to practice, it is expected that athletes can practice with focus without being disturbed by the conditions of the place to practice. In addition, the condition of the training ground can affect the physical condition of athletes in the short and long term.

In the XXth PON which will be held in Papua Province in 2020, Weightlifting is one of the flagship sports contingents of the Central Java province that is contested among 37 other sports. And as many as 21 athletes from the Great Weight Lifting Association, Bodybuilding, Indonesian Weightlifting (PABBSI) who participated in the prequalification, 13 athletes (62%) passed and were entitled to participate in PON XX.

The presence of excessive dust levels in the exercise room air in addition to disrupting the quality of short-term health can also cause disease if exposed for a long time. According to [1] SNI-19-0232-205 it was mentioned that the Zinc Oxide dust threshold value in the room

was 10 mg / m³ air. If it exceeds 10 mg / m³, treatment must be taken so that the dust does not interfere with the health of the athletes.

In spirometry measurements on workers exposed to lime dust with exposure concentrations above 3mg / m³, it was found that more than 50% of workers experienced mild, moderate to severe pulmonary physiology [2] In other studies, there was a relationship between vital lung capacity and cardiorespiratory. This relationship means that with the better vital capacity of the lungs the athlete can have stable endurance. (Ilman alifa 2016) [3]. In other studies the effect of vital lung capacity on swimming ability was 79.2% [4]. This shows that good lung physiology values greatly affect the stamina of the athlete in various sports.

From this basis, researchers want to look for the influence of dust and the environment of the training ground on weight lifters and weightlifting Central Java. So that the results of this study obtained an overview and causes of decreased athlete stamina and obtained solutions so that the quality of athletes does not decrease.

2 Methods

This type of research is analytic observation research. Research uses case and control groups. Where each group gets the same treatment and testing. In the case group are the Central Java Weightlifting athletes who will be compared with the KONI National Weightlifting athletes. The sample size used is the total sample. Where all athletes will be used as respondents.

In the pulmonary physiology parameter, each respondent both controls and cases will be measured using a digital spirometer. The tool used with the Digital Pony Fx brand Digital spirometer. This tool is able to measure the values of various pulmonary physiology parameters, but in this study only tested with KVP, FEV, FEV 1. Testing on digital spirometry will produce values, comparison of values and standards, and the interpretation of results in the form of Normal, Mild Disorders, Moderate Disorders, or IRON Interference. This assessment tool automatically calculates from the factors of Gender, Age, IRON Body, Height, smoking habits or not.

Spirometry is a physiological test that tests measuring levels the maximum volume of air that can reach when maximum inspiration and expiration. the most important parameter in measuring spirometry is FVC. FVC is the total volume of air that can be released by force and as much as possible by respondents whose assessment in a digital spirometer starts from the full inspiration stage. Whereas FEV1 is the expiratory volume in the first second of the FVC. The ATS ERS standard covers the measurement of FEV1 [5] but by testing the FEV in the first 6 seconds it can also be used as a reference for a decrease in the vital capacity of the lungs [6]

Spirometry measurement also requires data on the physical condition of the respondent namely body weight, height, smoking habits, ethni, gender. This is needed in filling the data on the spirometer [7].

In testing the level of environmental dust using a High Volume Sample that can suck up to 500 liters of air / minute. While the filter paper used is TFA with a pore diameter of 10 microns the constant weight is obtained by drying at 131 and repeated until the constant weight is obtained, if the difference in weight of the first and second weightings does not exceed 0.2 mg.. The dust value is calculated from dust captured on filter paper and calculated using the gravimetric method.

Testing the dust levels of the exercise room was carried out 3 times at each location before the exercise and during the exercise. Difference in value of room dust in before and during exercise is the value of dust from training activities [8].

Environmental measurements are carried out by measuring the temperature and humidity conditions in the training environment. Measurement using environmental tests which can measure temperature and humidity in real time.

3 Results and discussions

3.1 Dust levels

In measuring dust levels at the study site. Obtained dust levels before use for exercise is an average of $1.35 \text{ mg} / \text{M}^3$. where this condition is still in good condition for the training ground. But when used for training, dust is increased by an average of $17 \text{ mg} / \text{m}^3$. this value exceeds the Quality Standards of $10 \text{ mg} / \text{m}^3$ [9]. this has the potential to cause health problems in athletes if exposed for a long time. From this data it means that the main source of dust in the air of the training room is coming from weight lifting. Where this exercise process uses Zinc oxide which is used by athletes to prevent slippery and sweat on the hands when lifting weights.

High levels of dust in the room due to the absence of air filters that function to filter the air that contains dust and produce clean air. The absence of an air filter is also made worse by the lack of air circulation in the room. One method of cleaning the air that can be used is a cyclone. R.D Ratnani, 2008 [10] explains that air pollution control techniques using a cyclone system have an effectiveness of up to 95% for particles with a diameter of 5-20 microns.

3.2 Measurement of comfort from athletes

Measurements were made using a questionnaire form, where from the questionnaire results of the athletes as many as 14, 3% felt uncomfortable with environmental conditions. Discomfort is felt due to lack of ventilation, air temperature and humidity levels that are not conducive as a weightlifting exercise site [11].

85.7% of the athletes were disturbed by the dust conditions in the practice room and consequently 57.1% of the athletes felt shortness of breath after practicing in the practice room.

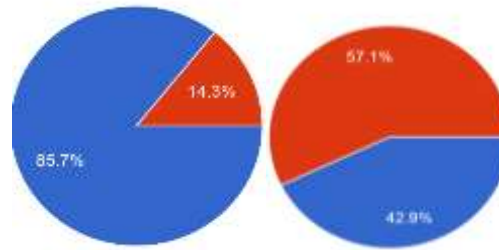

Fig. 1.

Fig. 2.

Fig 1. shows the percentage of athletes' comfort in the Exercise Room
Fig 2. shows the percentage of shortness of breath in the practice room

3.3 The condition of the lungs

All respondents are weight lifting athletes who have more than 5 years' training time. Overall athletes have a good level of nutrition. 1/3 of total respondents have mild disorders. This mild disturbance is found in athletes who have 5-10 years of practice time. Not yet found athletes who have moderate to severe disorders. From the examination results found 33, 33% of respondents experienced mild restrictions. others have normal FVC values. Of all respondents none had obstruction. Even though the athletes only train for 3 hours per day and 5 times a week, it seems that the training ground that is not good has greatly impacted the physiology of the lungs [12].

Complaints that occur in athletes are the condition of being tired and not strong enough to do repetition or repetition. In athletes who have normal lung conditions, symptoms of fatigue do not occur.

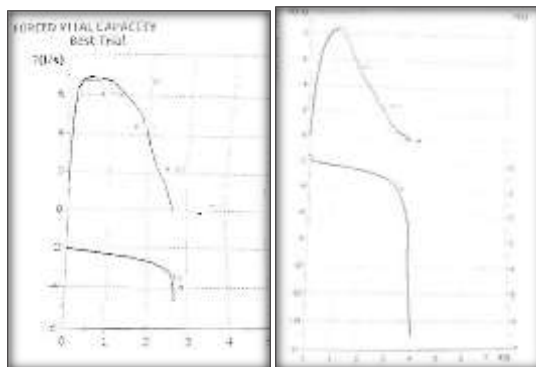

Fig. 3.

Fig. 4.

Fig 3. is Middle restriction spirometry graphic
Fig 4. is Normal Spirometry Graphic

From the picture shown, in middle restriction, the flow value only reaches a peak at value 6 l/s, whereas in normal lungs a higher flow value is obtained above 8 l/s. In addition, the amount of air volume released there is also a significant difference in athletes who experience restrictions is only able to reach 3 liters. Different from normal lungs can reach 4 liters with expiratory flow values up to 14 l/s [13].

Ventilation disorders consist of restriction disorders and obstruction disorders. Restriction is a disruption to lung development by any cause. On interference restriction, the lungs become stiff so that the attraction inside bigger than the chest wall shrinks. Pulmonary volume be washing and narrowing the ribs. As the measured parameter is VC. Normal VC value 80% -120% prediction. VC is less than 80% of the predicted value considered a restriction disorder. VC is more than 120% value prediction is a state of over or hyperinflation. In obstruction disorders, indicate the existence decreased expiratory flow velocity and vital capacity normal. In obstruction, the air flow is more intense. On obstruction [14].

Table 1. spirometry testing

Parameter	Normal	Obs	Res	Comb
FVC	≥80% Pred (N)	N	<N	<80% Pred
FEV1	≥80% Pred (N)	<N	N/<N	<80% Pred
FEV1/FVC	N (>70 %)	<70%	>70%	<70 %
FVC/FVC Pred	≥80%		<N	

Table 2. Spirometry category

Categori	Restriction	Obstruction
Normal	>80 %	>80 %
mild	70-79 pred FVC	70-79 pred FEV1
Mild-middle	60-69 % Pred FVC	60-69 % FEV1
heavy	35-49 % Pred FVC	35-49 % FEV1
Very heavy	< 35 % Pred FVC	< 35 % Pred FEV1

Allegations of a very strong influence of dust levels at the training ground that affected the condition of the lungs of athletes were strengthened in statistical tests. Based on the regression test, the results of the exercise were obtained

$$Y = a + \beta_1 X_1 + \beta_2 X_2 + \dots + \beta_k X_k$$

With $a = -48,856$, $\beta_1 = 7,269$, and $\beta_2 = 95,846$. It can be seen that the regression equation is:

$$Y = -48,856 + 7,269X_1 + 95,846X_2$$

Based on the above calculation, the regression coefficient interpretation is as follows :

1. The constant value $a = -48,856$ means that if all the variables of the environmental conditions of the training ground and the effect of zinc oxide have not changed, the total lung physiology condition is $-48,856$. This value has a negative effect, meaning that there is a decrease in the number of pulmonary physiology conditions by $-48,856$ if the environmental conditions of the training ground and zinc oxide increase.
2. Coefficient value $\beta_1 = 7.269$ means that if the environmental conditions at the training site have increased 1 unit, then the variable environmental conditions with the condition

of pulmonary physiology is positive. Means the resulting condition of the pulmonary physiology shrinking or decreasing

3. Coefficient value $\beta_2 = 95,846$ means that if the condition of the influence of zinc oxide has increased by 1 unit, then the variable condition of the influence of zinc oxide with pulmonary physiology is positive. Means the resulting condition of the pulmonary physiology shrinking or decreasing

Based on the probability value, it is known that the environmental conditions of the training ground with the influence of zinc oxide obtained a value of $0.756 > 0.05$, then there is no significant correlation. It is also known, that the environmental conditions of the training ground with the condition of the lung physiology obtained $0.982 > 0.05$, then there is also no significant correlation.

4 Conclusions

Condition of Dust in the training ground affects the physiology of the athlete's lungs, although currently the disturbance is still in a mild level, but will be at high risk if there is no improvement in environmental conditions. Lack of air circulation and the absence of air filters, causing the accumulation of zinc dust in the exercise room. This makes the athlete feel uncomfortable with the training conditions.

The further research needs the air filters and exhaust fans are provided to clean dust inside the training ground and make air circulation better. The need for periodic measurements of the condition of the pulmonary athlete's weight lifting so that health disorders can be monitored due to the exercise process

References

- [1] Badan Standarisasi Nasional. Nilai Ambang Batas (NAB) zat kimia di udara tempat kerja [Internet]. Nilai ambang batas (NAB) zat kimia di udara tempat kerja. 2005.
- [2] Bährle-Rapp M, Bährle-Rapp M. Zinc Undecylenate. Springer Lex Kosmet und Körperpfl. 2007;(6):601–601.
- [3] Bakhtiar A, Amran WS. Faal Paru Statis. J Respirasi. 2019;2(3):91.
- [4] Bakhtiar A, Tantri RIE. Faal Paru Dinamis. J Respirasi. 2019;3(3):89.
- [5] Beckett WS, Chalupa DF, Pauly-Brown A, Speers DM, Stewart JC, Frampton MW, et al. Comparing inhaled ultrafine versus fine zinc oxide particles in healthy adults: A human inhalation study. Am J Respir Crit Care Med. 2005;171(10):1129–35.
- [6] Graham BL, Steenbruggen I, Barjaktarevic IZ, Cooper BG, Hall GL, Hallstrand TS, et al. Standardization of spirometry 2019 update an official American Thoracic Society and European Respiratory Society technical statement. Am J Respir Crit Care Med. 2019;200(8):E70–88.
- [7] Graham BL, Steenbruggen I, Barjaktarevic IZ, Cooper BG, Hall GL, Hallstrand TS, et al. Standardization of spirometry 2019 update an official American Thoracic Society and European Respiratory Society technical statement. Am J Respir Crit Care Med. 2019;200(8):E70–88.
- [8] Ilmu B, Komunitas K, Kedokteran F, Kesehatan I, Jambi U. Penyakit Sistem Respirasi Akibat Kerja Armaid Darmawan. :68–83.

- [9] Mubarak W, Kumaidah E, Supatmo Y. Perbedaan Nilai Vital Capacity, Forced Vital Capacity Dan Forced Expiratory Volume in One Second Antar Cabang Olahraga Pada Atlet Usia 6-12 Tahun. *J Kedokt Diponegoro*. 2015;4(4):1619–25.
- [10] Mubarak W, Kumaidah E, Supatmo Y. Perbedaan Nilai Vital Capacity, Forced Vital Capacity Dan Forced Expiratory Volume in One Second Antar Cabang Olahraga Pada Atlet Usia 6-12 Tahun. *J Kedokt Diponegoro*. 2015;4(4):1619–25.
- [11] Ratnani R. Teknik Pengendalian Pencemaran Udara Yang Diakibatkan Oleh Partikel. *J Momentum UNWAHAS*. 2008;4(2):114195.
- [12] Ruppel GL. Spirometry. *Respir Care Clin N Am*. 2014;3(2):155–81.
- [13] Syahda IA, Damayanti I, Imanudin I. Hubungan Kapasitas Vital Paru-Paru Dengan Daya Tahan Cardiorespiratory Pada Cabang Olahraga Sepak Bola. *J Terap Ilmu Keolahragaan*. 2016;1(1):24.
- [14] Vandevoorde J, Verbanck S, Schuermans D, Broekaert L, Devroey D, Kartounian J, et al. Forced vital capacity and forced expiratory volume in six seconds as predictors of reduced total lung capacity. *Eur Respir J*. 2008;31(2):391–5.

Athletes' Stress Determinants when Countering Fear of Failures at Their Training Center Program

Heny Setyawati¹, Didik Rinan Sumekto², Nur Haziyan³, Fatona Suraya⁴, Sungkowo⁵,
Thania Kusumaningtyas⁶, Laksmana Pandu Pratama⁷
{henysetyawati@mail.unnes.ac.id¹, didikrinan@unwidha.ac.id², nur.haziyan@fsskj.upsi.edu.my³}

Universitas Negeri Semarang, Semarang, Indonesia¹,
Widya Dharma University, Klaten, Indonesia²,
Universiti Pendidikan Sultan Idris, Perak, Malaysia³

Abstract. Self-confidence is automatically influential towards athletes' performance. This research aims to reveal the professional athletes' determinants constituting with their individual experience at the Regional Training Center Program. 290 in-training program athletes at the Training Center, the Indonesian National Sports Committee of Central Java Province, Indonesia were involved to be the respondents. Data were collected from self-rated questionnaire with a 5-Likert scale. Data analysis used the SPSS program for revealing athletes' stress determinants. The results showed the mean of excessive exercise training ($M = 4.51$, $SD = .885$), hedonic lifestyle ($M = 3.17$, $SD = 1.00$), aversive stimulation ($M = 3.51$, $SD = .985$), and overload competition ($M = 4.25$, $SD = .719$) were significant. Meanwhile, the factorial analysis claimed that two-fixed components gained 44.84% of the variances (first component = 31.69%; second component = 13.15%). These determinants coherently accomplish a comprehensive examination to strengthen athletes' self-confidence in the training program.

Keywords: athletes' self-confidence, countering failures, stress determinants

1 Introduction

Athletes' stress triggers careful changes, such as focus narrowing, general confusion, and increased self-consciousness, which interfere with success of athletes. Herein, the stress methods of coaching athletes have demonstrated a decrease in the amount of injury levels over a season of their training center program or level of participation. [1] confirm that stress appears often as athletes practice for professional competition. The appearance includes physiological and physical symptoms, such as leading stomach weight, throat lumping, sleeping disorders, and heart palpitation, as well as can come from non-training areas and social pressure [2]. [3] points out that stress as an extreme pressure or stress imposes on a body expressed per area unit is seen as the way human beings react to situations that frighten, intimidate, or excite them. When these problems continue, there is a tendency in the human cognitive process to break down tiredness, or even damage to the body's immunity system that can result in the mental failure. Another understanding, stress is a key principle for understanding both life and evolution, fulfilling the adaptive responses depending on the capacities of the strong athletes [4].

Current concepts of stress also agree that stress is a personal experience induced by pressure or demands on an individual and influences the capacity of the individual to cope with that task, or rather, their understanding of it. Usually, stress issues have complex and various causes and cannot be related exclusively to incidents in the training centre program [4]. In the context of determining the most appropriate stress management intervention, the role of assessment within the stress process is central. Specifically, the stress management mitigation strategy indicates performers are responding to demands with negative effects on performance. Of this conditional effort, the athletes can afford the following three steps to reduce their stress, namely: firstly, athletes learn the fundamentals of skills in a stress-free atmosphere by working closely with the practitioner; secondly, by raising their freedom from the practitioner, athletes are more self-directed and begin to apply their skills in non-hazardous situations; and thirdly, athletes are advised to use them and also to test the efficacy of their skills; in a stressful, non-sport environment [5]. Further, [6] re-explained three main points in overcoming athletes' stress, namely: managing the stress of preparation, managing the stress of competition and managing daily stress.

In sports psychology, stress is seen as a source of excitement that is directly linked to the particular task requirement of the demand that a situation imposes on person competing in competitive sports in order to achieve excellent results, while others believe that stress has devastating effects on psychological health, stress can be good or bad [3]. As the earlier information, sports are classified into two general types, namely: dynamic (e.g.: producing a volume load on the left ventricle) and static (e.g.: producing a pressure load on the left ventricle) sports, which endorsed to the intensity level (low, medium, high) and the presence or absence of a collision for contextual factor [7]. These two types of sports potentially cause with the athletes readiness or failures when they are not ready to manage it. Consequently, the competitive training programs of some athletes provide some sort of stress management that focuses on achieving an optimal mental state of pre-performance [5]. Herein, athletes' life experience upon their stress can be confirmed that the athlete felt that when anything to be positive happened, she was just optimistic. Then she replied, "I'm bothered by how I feel, as if I'm not sure how I'm playing so I don't think I 'm helping the team and I'm starting to get down on myself." Meanwhile, another athlete said that she did not have a lot of self-confidence either. When she was asked, "How confident are you in team's ability to succeed?" She replied, "Truly confident. I never think I'm doing good as an individual, but we're successful as a team." [8].

Some previous researches on athletes' stress determinants participating in sports performance, management, and stress relieving effects helped athletes alleviate tension during their sport performance and training outputs. On the other hand, over-stressed including overloading, burning out, dropping out and developing maladaptive fatigue syndrome affected the mental health of athletes, such as perceptions of psychological, emotional, and behavioral issues in their training schedule [6]. Next, [1] emphasized that the comparison of physical and psychological stress symptoms revealed significant differences between the recorded scores. Accordingly, we noted a slight effect of symptom of muscle tension and main motivational effect. Whereas the findings of the physiological, mental, emotional, and existential ratings of psychological stress symptoms were strongly consistent. On the other hand, stress had been shown to adversely affect both psychological and physical health. Individuals with chronic stress were at higher risk for severe health problems such as rheumatoid arthritis, cardiovascular disease and other cancers as well as mental health issues such as anxiety, depression, disordered eating and alcohol use [9]. [10] reinforced that a number of stress

reduction approaches were related to increased stress awareness and improved results for athletes. The results indicated that a variety of diverse design features, for example: treatment implemented and stress function outcome measured influence the effectiveness of stress management. Such design features were essential when developing treatments for athletes of varying sports, ages, and overall competitive standards. Last but not least, importantly, the awareness of athletes in the situation triggered the affective reaction, which demonstrated the importance of mental toughness in recognizing the perceived stress level of athletes as well as the affective stress response. Emotions also tended to play a significant role in the practice of developing junior athletes towards professional sports [11].

This research relied on two research questions regarding athletes' stress determinants as revealed at their sports training center program, as follows: (1) Do athletes' stress determinants influence their self-confidence when joining in the sports training center program? (2) Can athletes' sports performance manage some deficiencies as driven by the stress determinants? This research addresses a self-rated questionnaire with a 5-Likert scale and attempts to highlight the purposeful aims. As stated in the literature review, this research investigates athletes' stress determinants as revealed at their sports training center program, handled by the Indonesian National Sports Committee of Central Java Province, Indonesia.

2 Methods

This research brought about 290 out of 451 athletes from the various sport fields at the Training Center Program using simple random sampling technique. These 290 athletes officially joined in the Indonesian National Sports Committee Registry of Central Java Province, Indonesia and were randomly selected to be the respondents. The obtainable data were carried out from the self-rated questionnaire figuring out of athletes' stress determinants as revealed at the training center program. The scaling system was purposely indicative with a 5-point Likert scale rubric to record athletes' individualized ratings of mood (5 = highly stressed, 4 = stressed, 3 = moderately stressed, 2 = slightly stressed, 1 = unstressed). This rubric was modified through a rigid content-validation process to adjust the indicators in each determinant. The stress determinants involved four influential values, namely: the excessive exercise training, hedonic lifestyle, aversive stimulation, and overload competition.

These determinants were initially aligned by the Cronbach's alpha reliability test [12] that accommodated other thirty-five athletes, who also joined in the training center program at the Indonesian National Sports Committee Registry of Central Java Province, Indonesia. The Cronbach's alpha internal consistency of athletes' stress determinants found their following alpha (α) value: .797 for athletes' excessive exercise training, .748 for athletes' hedonic lifestyle, .695 for athletes' aversive stimulation, .702 for athletes' overload competition. Data analysis used descriptive statistics, Pearson correlations, and factor analysis tests [13], which established the values of four perceived athletes' stress determinants deriving the principal components analysis with the Eigenvalue [14] to indicate athletes' stress levels that triggered their self-confidence during joining in the training center program. All statistical analyses completely applied for the IBM SPSS Statistics software, version 20 software packages to data processing.

3 Results and discussions

First of all, this descriptive analysis that was in accordance with athletes' stress determinants corresponded with the descriptive and frequencies statistics results (TABLE 1 and Fig. 1). The determinant of excessive exercise training descriptively gave evidence of 6 (2.1%) athletes were unstressed, 9 (3.1%) athletes were slightly stressed, 14 (4.8%) athletes were moderately stressed, 63 (21.4%) athletes were stressed, and 199 (68.6%) athletes were highly stressed if they experienced with their excessive exercise training. The result also confirmed that the highest score of athletes' excessive exercise training raised 5.00 ($M = 4.51$; $SD = .885$; $n = 290$). The empirical evidence of athletes' stress established highly stressed level with the frequency of 199 (68.6%). To be most effective, mental and physical symptoms require specific and individual psychological competency programs. This feature applies to the frameworks for both reduction and restructuring. For example, a performer who has high physical anxieties will typically be offered a somatic (i.e., physical) relaxation procedure, such as gradual muscle relaxation, through the reduction method, Trying to balance diagnosis with physical reaction [5]. Anyway, the sport psychological profile can predict competitive anxiety, moods, and self-efficacy scores, and coping control in these predictive models is one of the most relevant dimensions of this. Similarly, self-confidence is the predictor that best predicts the psychological profile of athletes, in particular through positive coping management, attitude regulation and careful monitoring [15]. The most notable symptom of stress is based on symptoms of muscular tension. Therefore it appears that stress is induced by observable apprehensive conduct and was evidenced by discomfort or cramps in some of the muscles of the body before the match. This condition can also be felt during sports as muscle spasms, twitching, 'clamping up' and constant pain during sports event [1].

Table 1. Athletes' Excessive Exercise Training

Likert's Scale	Fre- quency	Percent	Valid Percent	Cumulative Percent
1.00 (Unstressed)	6	2.1	2.1	2.1
2.00 (Slightly stressed)	9	3.1	3.1	5.2
3.00 (Moderatelystressed)	14	4.8	4.8	10.0
4.00 (Stressed)	62	21.4	21.4	31.4
5.00 (Highly stressed)	199	68.6	68.6	100.0
Total	290	100.0	100.0	

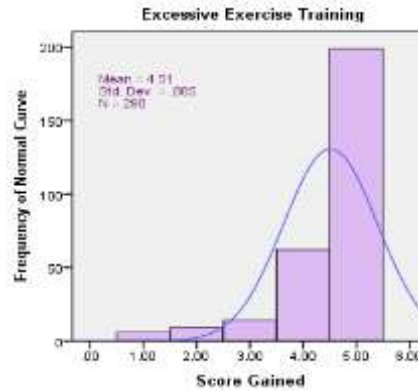

Fig. 1. Histogram on athletes' excessive exercise training

Second, the analyses of hedonic lifestyle (TABLE 2 and Fig. 2) were summarized in the following description: 12 (4.1%) athletes were unstressed, 57 (19.7%) athletes were slightly stressed, 119 (41.0%) athletes were moderately stressed, 71 (24.5%) athletes were stressed, and 31 (10.7%) athletes were highly stressed when they spent times to have the hedonic lifestyle. The result also confirmed that the highest score of athletes' hedonic lifestyle earned 3.00 ($M = 3.18$; $SD = 1.00$; $n = 290$). The empirical evidence of athletes' stress found moderately stressed level with the frequency of 119 (41.0%). The impact of eating disorders, depression and suicide, anxiety and stress, over-training, sleep disorders and attention deficit or hyperactivity disorder triggered to athletes' worse hedonic lifestyle [16]. This case might be badly impacted either since athletes were failed to show lower prevalence of hypertension with adherence to routine exercise training and a balanced lifestyle. Therefore, changes in lifestyle were enough to maintain maximum regulation of blood pressure levels [17].

Table 2. Athletes' hedonic lifestyle

Likert's Scale	Frequency	Percent	Valid cent	Per- cent	Cumulative Percent
1.00 (Unstressed)	12	4.1	4.1		4.1
2.00 (Slightly stressed)	57	19.7	19.7		23.8
3.00 (Moderately stressed)	119	41.0	41.0		64.8
4.00 (Stressed)	71	24.5	24.5		89.3
5.00 (Highly stressed)	31	10.7	10.7		100.0
Total	290	100.0	100.0		

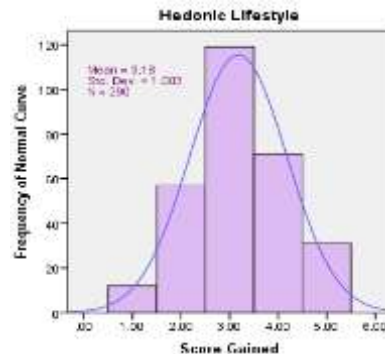

Fig. 2. Histogram on athletes' hedonic lifestyle

Third, the analyses of aversive stimulation (TABLE 3 and Fig. 3) were due to the following description: 4 (1.4%) athletes were unstressed, 41 (14.1%) athletes were slightly stressed, 98 (33.8%) athletes were moderately stressed, 96 (33.1%) athletes were stressed, and 51 (17.6%) athletes were highly stressed when they were ignorant and led to the aversive stimulation. The result also confirmed that the highest score of athletes' aversive stimulation was 3.00 ($M = 3.51$; $SD = .985$; $n = 290$). The empirical evidence of athletes' stress found moderately stressed level with the frequency of 98 (33.8%). The description of aversive stimulation relied on the athletes who were positive and had strong approaches to dealing with chronic stress. Alternatively, if the stressed athletes were biologically vulnerable due to age, genetic, or constitutional factors, they were deeply intense and too persistent to suffer from the disease. These athletes faced the real condition if they had little psycho-social support and weak coping skills [4]. Therefore, athletes were required to test the long-term efficacy of motor-mental rituals and to evaluate the efficacy of additional innovative personality to boost their performance [18]. Besides engaging the awareness of the individual reactions to the rehabilitation incentive and the effects of other factors were critical for predicting the rehabilitation and carrying out supporting interventions for athletes [19]. Specifically, athletes' moods assistance identified whether athletes were adapting to training loads and competition. Mood indicators could detect processes such as over-training or problems to adapt psychologically to athletes stress. Likewise, the data suggested that a good development of aspects could contribute to a lower development of negative feelings and an increase in adaptive moods. Thus, coaches could use these indicators to assess how the athletes approached the competition and helped them [15]. If an athlete lacked motivation or the most modest amount of arousal to stay focused and get going, his or her performance on various tasks was likely to suffer [1]. This could array through their facial expression, voice sonority and loudness, and gestural movements [20] as the indication of showing the stress levels.

Table 3. Athletes' aversive stimulation

Likert's Scale	Frequency	Percent	Valid Percent	Cumulative Percent
1.00 (Unstressed)	4	1.4	1.4	1.4
2.00 (Slightly stressed)	41	14.1	14.1	15.5
3.00 (Moderately stressed)	98	33.8	33.8	49.3
4.00 (Stressed)	96	33.1	33.1	82.4

5.00 (Highly stressed)	51	17.6	17.6	100.0
Total	290	100.0	100.0	

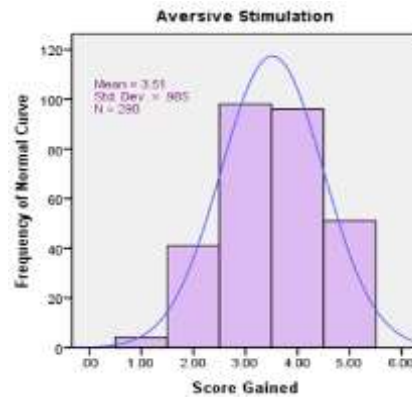

Fig. 3. Histogram on athletes' aversive stimulation

Fourth, the analyses of overload competition (TABLE and Fig. 4) related to the following findings: 1 (.3%) athletes were unstressed, 4 (1.4%) athletes were slightly stressed, 29 (10.0%) athletes were moderately stressed, 141 (48.6%) athletes were stressed, and 115 (39.7%) athletes were highly stressed when they spent a lot of times with their overload competition schedules. The result also confirmed that the highest score of athletes' overload competition gained 4.00 ($M = 4.26$; $SD = .719$; $n = 290$). The empirical evidence of athletes' stress engaged in stressed level with the frequency of 141 (48.6%). The discussion carried out of the stress that became parts and parcels of all sports competitions. It was realized that sports competition related to the cognitive functions, mental, and body control [4]. When athletes became overload in competitions, they might rapidly restore their attention to their performance [21]. Athletes' competition aspects conveyed their thinking about performance, goals that might have been set, self-confidence of physical and psychological attention, and weather and environmental conditions that might cause the results in athletes' different stress responses [5]. Conversely, athletes' overload competition they had attended in a huge schedule might negatively influence to their mental fatigue and physical condition. Hence, the mounting pressure of maintaining a high-level of performance throughout their competition had eroded the instability and nerves accordingly.

Table 4. Athletes' overload competition

Likert's Scale	Frequency	Percent	Valid Percent	Cumulative Percent
1.00 (Unstressed)	1	.3	.3	.3
2.00 (Slightly stressed)	4	1.4	1.4	1.7
3.00 (Moderately stressed)	29	10.0	10.0	11.7
4.00 (Stressed)	141	48.6	48.6	60.3
5.00 (Highly stressed)	115	39.7	39.7	100.0
Total	290	100.0	100.0	

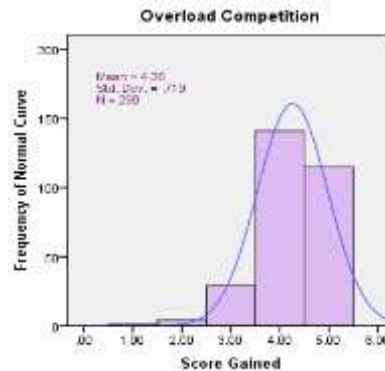

Fig. 4. Histogram on athletes' overload competition

Meanwhile, the athletes' self-confidence cohered with their day-to-day performance as revealed at the training center program. These determinants confirmed four potent contributions, such as excessive exercise training, hedonic lifestyle, aversive stimulation, and overload competition. This research accomplished 290 elite athletes in the various sport fields who were professionally trained at the training center program, Indonesian National Sports Committee Registry of Central Java Province. The results of descriptive statistics upon the athletes' stress determinants were shown in the following summary: excessive exercise training ($M = 4.51$; $SD = .885$), hedonic lifestyle ($M = 3.17$; $SD = 1.00$), aversive stimulation ($M = 3.51$; $SD = .985$), and overload competition ($M = 4.25$; $SD = .719$). Mean and standard deviation of this descriptive statistics constituted with a 5-point-Likert scale to measure athletes' stress levels. Further, the values of skewness and kurtosis among these determinants were summarized as follows: excessive exercise training (-.2.197; 4.812), hedonic lifestyle (.028; -.399), aversive stimulation (-.148; -.645), and overload competition (-.880; 1.253) were insignificant for athletes' self-confidence influence when engaging in the day-to-day training center program. Of athletes' stress' skewness and kurtosis values, the data were conditionally normal. However, the lowest mean of athletes' stress determinants referred to the hedonic lifestyle ($M = 3.17$), whilst the highest mean was the excessive exercise training ($M = 4.51$).

Pearson correlations analysis corresponded with the relationships among four perceived athletes' stress determinants as revealed in their training center program that was conducted by the Pearson product-moment correlation coefficients. However, the significant correlations among four determinants were significantly confirmed that $r = .442$, $n = 290$, $p < .000$. The highest level of significance value of athletes' stress determinants relied on their aversive stimulation (.442**) associated with the lowest level of their traumatic experiences (.126*). However, the significance value among four perceived athletes' stress determinants was consequently positive and significant with $p < .01$ level for 2-tailed prediction. TABLE 5 comparably showed the correlation coefficients in the following sequences, namely: .442**, .218**, .168**, and .153**.

Table 5. Pearson Correlations of Athletes' Stress Determinants (Independent Variables)

Athletes' Stress Component	1	2	3	4
----------------------------	---	---	---	---

Excessive exercise training	Pearson Correlation	1	.126	.153**	.084
	Sig. (2-tailed)		*	.009	.154
	N	290	.032	290	290
Hedonic lifestyle	Pearson Correlation	.126	1	.442	.218
	Sig. (2-tailed)	*		**	**
	N	.032	290	.000	.000
Aversive stimulation	Pearson Correlation	.153	.442	1	.168
	Sig. (2-tailed)	**	**		**
	N	.009	.000	290	.004
Overload competition	Pearson Correlation	.084	.218	.168	1
	Sig. (2-tailed)	.154	**	**	
	N	290	.000	.004	290

*. Correlation is significant at the 0.05 level (2-tailed).

**. Correlation is significant at the 0.01 level (2-tailed).

There were four determinants dealt with the principal components analysis (PCA) to address the factor analysis. Prior to identifying the components, the factor analysis suitability was tested to obtain the data. In this factor, the correlation matrix showed the coefficients availability of .107 and above. Meanwhile, the Kaiser Meyer-Olkin of sampling adequacy was .746, passing through the expected value of .6 and the Bartlett's test of Sphericity showed $p = .000$. This correlation matrix addressed the significance of statistics values and strengthened its correlation matrix factorability. The PCA showed the existence of four determinants with the Eigenvalue outreaching 1, was firmly estimated by 31.69%, 13.15%, 12.08%, and 11.01% of the empirical data relatively (see TABLE 6). Herein, the scree plot conveyed the fix portrait by confirming four determinants. However, this scree plot was engaged in two axes disapproval for the further examination and verified by the parallel analyses. It addressed two axes with the Eigenvalue advocating the criterion values for the purposelessly brought about into the accessible matrix data, e.g.: 4 determinants x 290 athletes.

Table 6. Total Variance Obtainable From Athletes' Stress Determinants

Determinants	Initial Eigenvalue			Extraction Sums of Squared Loadings			Rotation Sums of Squared Loadings ^a	
	Total	% of Variance	Cumulative %	Total	% of Variance	Cumulative %	Total	
Excessive Exercise Training	2.535	31.691	31.691	2.535	31.691	31.691	1.539	
Hedonic Life-style	1.052	13.156	44.847	1.052	13.156	44.847	1.413	
Aversive Stimulation	.966	12.081	56.927	.966	12.081	56.927	1.100	
Overload Competition	.881	11.012	67.939	.881	11.012	67.939	1.187	

Extraction Method: Principal Component Analysis.

a. When components are correlated, sums of squared loadings cannot be added to obtain a total variance.

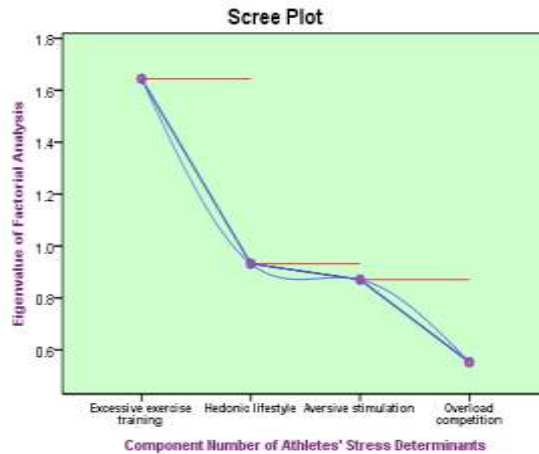

Fig. 5. Screen plot of athletes' stress determinants

The factorial analysis results (see TABLE 6) verified 2 substantial components with the value of 44.84%. The first component showed 31.69%, while the second component recorded 13.15%. The oblimin rotation was confirmed to verify the first and second component of factorial analyses. The revolved output indicated the simple structure existence with both components referring to the squared loadings numbers and four influential determinants that resulted significantly on the first component. Furthermore, the clarification upon first and second components relied on the preliminary outputs on athletes' influential stress determinants scale. However, the first component showed the positive effect, whereas second component partially indicated the negative affect which had a weak negative correlation between both of them (see TABLE 7). The function of either positive or negative effect of Eigenvalue derivation was usable in scales separately. Of this factorial analysis, the description of athletes' conditional performance might be influential from their fear of failure, sadness, anger, frustration, dissatisfaction, increase in the training targets, injury, inconvenience, inability to cope with sensory information, and intolerance climates. All these sources potentially became athletes' stress appearance.

Table 7. Pattern & Structure Matrix for PCA with The Oblimin Rotation of Two-Component of Athletes' Stress Determinants

Determinants	Pattern coefficients		Structure coefficients		Communalities
	1 st Component	2 nd Component	1 st Component	2 nd Component	
Aversive Stimulation	.639	-.445	N/A	-.442	1.000
Hedonic Lifestyle	.574	-.607	N/A	-.1000	1.000
Excessive Exercise Training	.312	N/A	N/A	N/A	1.000

Overload Competition	.561	N/A	.766	N/A	1.000
----------------------	------	-----	------	-----	-------

Note: major loadings for each item were in boldface

Of the overall analyses, this research realized to have limitations. The limitation firstly relied on the use of 'custom-tailored' self-rated questionnaire that was considered to be subjective by some athletes. Hence, this research suggested identifying some speculative fulfillment till the assertive validity and reliability testing were accurately examined. Secondly, the limitation accorded with the timely and data entry accuracy regarding athletes' eligible appropriateness situation conducted any deviation from this practice that might corrupt the data. Thirdly, the respondents of this research were entirely young athletes engaged in the training center program whose backgrounds might reflect to the multiple academic, social, and economic status, hence their understanding levels relating to the questionnaire fulfillment might be merely applicable to this cohort and might not be generalizable

4 Conclusions

Athletes' stress factors can be triggered from the internal and external contributions. All athletes' endeavor and activities daily shall reflect the stress levels which encourage the individual athletes to take actions. In this remarkable conclusion, athletes' stress levels in joining the sports' training center program can be verified in low, middle, and high-excessive levels. The experience of facing stress stably addresses athletes' tendency experiencing in the competitive positions of their self-esteem challenges. Stress management in sports leads to how the athletes cope, control, and reduce the deliverance of stress' negative existence. The major determinants of athletes' stress backgrounds constitute to the positive and constructive expectation among athletes. This means that athletes' excessive exercise training, hedonic lifestyle, aversive stimulation, and overload competition can be possibly reduced. On the other hand, this conclusion empirically record four influential determinants of athletes' stress as shown in the data analyses. These four determinants significantly stimulate sense of athletes' self-confidence to gain and maintain their best performance during joining in sports' training center program. Last but not least, the specially programmed attention towards athletes shall be addressed to control their stress levels remain low and manageable, to do with the imagery practices becomes adhered, and to observe athletes' mental rehearsal continuity prior to starting the relevant physical performance.

Acknowledgement

This research was funded by Daftar Isian Pelaksanaan Anggaran (DIPA), Universitas Negeri Semarang, Indonesia.

References

- [1] SH. Nassib, B. Mkaouer, SH. Riahi, SM. Wali, and S. Nassib, "The potential effects of relevant symptoms perceived by athletes and coping strategies upon athletics performance in competitive sport events". *Journal of Psychological & Clinical Psychiatry*, vol. 10, no. 6, 2019, pp. 213-219. <https://doi.org/10.15406/jpcpy.2019.10.00656>

- [2] MJ. Hamlin, D. Wilkes, CA. Elliot, CA. Lizamore, and Y. Kathiravel, "Monitoring training loads and perceived stress in young elite university athletes". *Frontiers in Physiology*, vol. 10. no. 34, 2019, pp. 1-12. <https://doi.org/10.3389/fphys.2019.00034>
- [3] WU. Eze, "The strategies for sports coach in managing stressful situations in sports competitions". *International Journal of Current Research and Academic Review*, vol. 3, no. 6, 2015, pp. 298-304.
- [4] B. Brajendra, and T. Rajesh, "Stress management technique for athletes during sports: A critical review". *Journal of Drug Delivery and Therapeutics*, vol. 8, no. 5-s, 2018, pp. 67-72. <https://doi.org/10.22270/jddt.v8i5-s.1956>
- [5] S. Hanton, O. Thomas, and SD. Mellalieu, *Management of Competitive Stress in Elite Sport*. In B. Brewer, *Sport Psychology* (1st edition), Blackwell Publishing, 2009.
- [6] R. Singh, "Stress role in sports performance of athlete's". *International Journal of Physical Education, Sports and Health*, vol. 4, no. 3, 2017, pp. 278-280.
- [7] JJ. Leddy, and J. Izzo, "Hypertension in athletes". *Journal of Clinical Hypertension*, vol. 11, no. 4, 2009, pp. 226-233. <https://doi.org/10.1111/j.1751-7176.2009.00100.x>
- [8] CR. Halladay, *Fear of Failure: An Exploratory Study of Division III Student-Athletes*. Ithaca College Master of Science Thesis, Graduate Program in Exercise and Sport Sciences Ithaca, New York, 2003.
- [9] R. Finnemore, "Perceptions of stress experienced by student-athletes in an education opportunity program". *Counselor Education Capstone*, vol. 44, 2017, pp. 1-29.
- [10] JL. Rumbold, D. Fletcher, and K. Daniels, "A systematic review of stress management interventions with sport performers". *Sport, Exercise, and Performance Psychology*, vol. 1, no. 3, 2012, pp. 173-193. <https://doi.org/10.1037/a0026628>
- [11] F. Moen, M. Hrozanova, TC. Stiles, and F. Stenseng, "Burnout and perceived performance among junior athletes—Associations with affective and cognitive components of stress". *Sports*, vol. 7, no. 171, 2019, pp. 1-11. <https://doi.org/10.3390/sports7070171>
- [12] LJ. Cronbach, and RJ. Shavelson, "My current thoughts on Coefficient Alpha and successor procedures". *Educational and Psychological Measurement*, vol. 64, no. 3, 2004, pp. 391-418. <https://doi.org/10.1177/0013164404266386>
- [13] D. Ary, LC. Jacobs, and CK. Sorensen, *Introduction to Research in Education* (8th Ed.). Belmont: Wadsworth, Cengage Learning, 2010.
- [14] J. Pallant, *SPSS Survival Manual: A Step by Step Guide to Data Analysis Using SPSS* (4th Ed.). New South Wales: Allen & Unwin, 2011.
- [15] RE. Reigal, JA. Vázquez-Diz, JP. Morillo-Baro, A. Hernández-Mendo, and V. Morales-Sánchez, "Psychological profile, competitive anxiety, moods and self-efficacy in beach handball players". *International Journal of Environmental Research and Public Health*, vol. 17, no. 241, 2019, pp. 1-13. <https://doi.org/10.3390/ijerph17010241>
- [16] CJ. Chang, M. Putukian, G. Aerni, AB. Diamond, ES. Hong, YM. Ingram, CL. Reardon, and AT. Wolanin, "Mental health issues and psychological factors in athletes: Detection, management, effect on performance, and prevention: American medical society for sports medicine position statement – executive summary". *British Journal of Sports Medicine*, vol. 54, no. 4, pp. 216-220. <https://doi.org/10.1136/bjsports-2019-101583>
- [17] S. Caselli, AV. Sequì, E. Lemme, F. Quattrini, A. Milan, F. D'Ascenzi, A. Spataro, and A. Pelliccia, "Prevalence and management of systemic hypertension in athletes". *The American Journal of Cardiology*, vol. 119, 2017, pp. 1616-1622. <http://doi.org/10.1016/j.amjcard.2017.02.011>.
- [18] IS. Perry, and YJ. Katz, "Pre-performance routines, accuracy in athletic performance and self-control". *Athens Journal of Sports*, vol. 2, no. 3, 2015, pp. 137-152. <https://doi.org/10.30958/ajspo.2-3-1>
- [19] G. Santi, and L. Pietrantonì, "Psychology of sport injury rehabilitation: a review of models and interventions". *Journal of Human Sport & Exercise*, vol. 8, no. 4, 2013, pp. 1029-1044. <https://doi.org/10.4100/jhse.2013.84.13>

- [20] DR. Sumekto, and H. Setyawati, "Revealing lecturer's paralinguistic attribution: How the visual manner contributes to students' non-cognitive skills". *Indonesian Journal of Applied Linguistics*, vol. 9, no. 3, 2020, pp. 559-571. <https://doi.org/10.17509/ijal.v9i3.23206>
- [21] JN. Gilbert, W. Gilbert, and C. Morawski, "Coaching strategies for helping adolescent athletes cope with stress". *JOPERD*, vol. 78, no. 2, 2007, pp. 13-24. <https://doi.org/10.1080/07303084.2007.10597967>
- [22] C. Faure, and KM. Appleby, "The logistical management of the organizational stress of elite "pipeline" athletes: Interventions of national performance directors in an olympic year". *The Journal of SPORT*, vol. 3, no. 2, 2014, pp. 139-183.
- [23] C. Wilson, EV. Bennett, AD. Mosewich, GE. Faulkner, PRE. Crocker, "The zipper effect: Exploring the interrelationship of mental toughness and self-compassion among Canadian elite women athletes". *Psychology of Sport & Exercise*, vol. 40, 2018, pp. 61-70. <https://doi.org/10.1016/j.psychsport.2018.09.006>
- [24] A. Kaya, "Decision making by coaches and athletes in sport". *Procedia - Social and Behavioral Sciences*, vol. 152, 2014, pp. 333-338. <https://doi.org/10.1016/j.sbspro.2014.09.205>
- [25] R. Sheinbein, "Psychological effect of injury on the athlete: A recommendation for psychological intervention". *AMAA Journal Fall/Winter*, 2016, 8-10.

Physical Growth and Motor Development of 5th Grade Students on Sub-district Pituruh Purworejo

Hermawan Pamot Raharjo¹, Fera Andriyani²
 {hermawan_pamot@mail.unnes.ac.id¹, feraandriyani6@gmail.com²}

Universitas Negeri Semarang, Semarang, Indonesia^{1,2}

Abstract. This research to determine the level of physical growth and motor development on 5th grade students SD Negeri in Pituruh District Purworejo. Descriptive quantitative research design was used. The sampling technique used Simple Random Sampling. Total respondent were 142 students. The study showed that physical growth and motor development were very thin; thin; normal; over weight; obese were 3 (2%); 26 (18%); 98 (69%); 13 (10%); 2 (1%), respectively. The motor development were excellent category; good category; medium category were 7 (5%); 32 (23%); 64 (46%), respectively. In the category of less than 37 students (26%), and in the category of very less as many as 2 students (1%). The conclusion was stated that physical growth in the 5th grade elementary school in Pituruh District were in the normal category and moderate category for the level of motor development.

Keywords: physical growth, motor development, elementary school

1 Introduction

Growth and development of movement in children is a condition where at the age of elementary school is very important in influencing the continuity of learning, especially in physical education learning. Growth is a process of improvement in terms of the size that occurs in someone who is quantitative. While development is a process of changing the ability of work organs and changes in functional capacity towards more organized [1].

Growth and development in children can be measured quantitatively and qualitatively, meaning that quantitative measurements can measure growth that can be seen visibly in the presence of differences such as height, weight, whereas measurements in child development that are not visible invisible but with certain criteria can measure motor development, for example cognitive development and motor development of children. Measuring the growth and development of children is done to see whether children already have the ability or growth in accordance with criteria in their age as an evaluation to give meaning to the results that have been achieved.

Growth and development of children is a complex matter, where many factors are influential and interconnected. The influencing factors are internal factors such as age, sex, heredity, nutrition, history of disease, as for external factors such as the environment, physical activity, food, etc [2].

In addition to some of the factors above regarding growth and development in each individual, of course there are significant differences, this is influenced by differences in the fundamental character of children, for example, during school learning hours there are children who are very active in participating in physical education and are fond of physical activity, conditioned there are other children who are lazy in doing the movement because of hot weather conditions or there are other things. This is very influential on the level of child development.

Childhood is a time when children love to play. This is often found when outside school hours or after school after school children spend more time playing. Like playing bicycle, running around, playing soccer which is usually done by many boys. Unconsciously that the activity will affect the child's motor development. However, as technology develops that children prefer to play online, this causes children's life patterns to turn into lazy and passive moves.

Physical growth is very closely related to the motor development of children. Motor is a development of controlling body movements through coordinated activities between the nervous system, muscles and brain. In motor development there is a relation with motor skills both fine and gross motor skills. A child's gross motor skills need to be trained and developed at all times with various activities. This development allows a child to do things better, including academic and physical achievements.

From the data of the researchers' initial observations, it is known that the conditions in the field indicate that the physical growth of elementary school students can be seen visibly with a difference, whereas in gross motor development in students there is indeed a difference between one individual and another, this is triggered by physical activity carried out by students who are different from each other, for example when playing, it can be seen that some children actively play outside the learning hours, some other children are busy with their respective activities such as just sitting around in groups, there are those who are engrossed in enjoying food, some who prefer to read books and so on. This affects the motor skills of children, children who tend to be active in sports or physical activities will certainly be different from children who rarely do physical activities both within the school environment and outside the school environment. So that the physical growth and motor development of elementary school students can run well, students are expected to frequently perform basic movements or perform physical activities [3].

The problems discussed are How Big is the Physical Growth Rate and Motoric Development of Elementary School Children in Class V in Pituruh District, Purworejo Regency. The purpose of this study was to determine how much the level of Physical Growth and Motoric Development of Elementary School Children in Class V of Pituruh Subdistrict, Purworejo Regency.

2 Methods

2.1 Research design

The method used in this study is a survey test and measurement of physical growth and motor development. The research subjects were students of Class V Public Elementary Schools in Pituruh Subdistrict, Purworejo Regency. The sample came from 10 schools with a total of 142 students, to determine the school by lottery.

2.2 Research instruments

The instruments used were the Anthropometric Test and the Motor Ability Test [4]. This test has a reliability of 0.93 and validity of 0.87. The tests include: (1) Anthropometric tests: Measurement of height and measurement of weight; (2) Motor Ability Test: Agility test (4x10 meter shuttle run), Ball throwing test (Coordination), Balance Test, Speed test.

2.3 Data analysis technique

Data analysis techniques used in quantitative research that are used are clear, which is directed to answer the problem formulation or test the hypothesis that has been formulated [5]. Then the data analysis technique uses the static methods that have been available. Data analysis is a percentage and then the results are described.

3 Results and discussions

Data on physical growth of students in terms of BMI (body mass index), it can be seen on table 1 and Fig 1, that of the 142 students consisting of 3 students (2%) included in the category of "very thin", "thin" category 26 students (18%), "normal" category "98 students (69%), in the" fat "category of 13 students (10%), and in the" obesity "category by 2 students (1%).

Table 1. Description of physical growth.

Categories	Interval	Frequency	Percentage
Very thin	< -3 SD	3	2%
Thin	-3 SD to <-2 SD	26	18%
Normal	-2 SD to 1 SD	98	69%
Fat	> 1SD to 2 SD	13	10%
Obesity	> 2 SD	2	1%
Total		142	100%

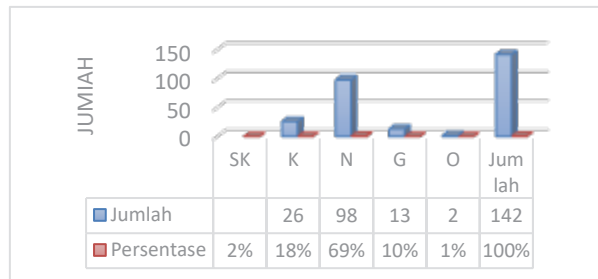

Fig. 1. Physical Growth.

The results of the number of 142 students in motor development students can be seen on table 2 and Fig. 2, consisted of 7 students (5%) had motor development in the excellent category, good category 32 students (23%), medium category 64 students (46%), in the category of less 37 students (26%) %, and very few categories as many as 2 students (1%).

Table 2. Description of motor development.

Categories	Interval	Frequency	Percentage
Very good	$\geq 229,17$	7	5%
Good	209,72- 229,16	32	23%
Medium	190,27-209,71	64	45%
Low	170,82-190,26	37	26%
Very low	$\leq 170,81$	2	1%
Total		142	100%

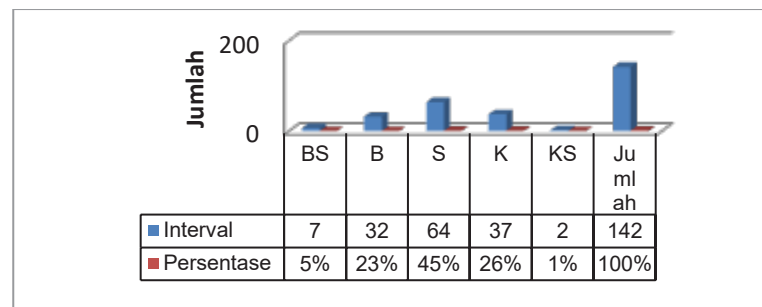

Fig. 2. Motor development.

From the results of the study showed that physical growth in terms of body mass index showed a dominant result that is normal. At the age of primary school on physical growth both men and women begin to experience significant growth this will continue to develop according to age. Children said to be normal means that the pattern of food consumption such as the nutritional intake received by children already fulfilling offspring also affects the level of physical growth in children [6].

For physical growth at primary school age can be influenced by other factors such as age, gender, illness, economic conditions, living environment, etc. In motor development from the results of the study showed that the results obtained are moderate. This relates to physical activities carried out by each student both during Physical Education hours and outside school hours. Other factors that can affect physical activity are environmental factors, especially in the school environment also affect student activities when students do activities at school. Lack of adequate facilities and infrastructure is also an obstacle for students to be able to carry out activities optimally. For example, the condition of the field or playing equipment will affect the activities of children, so that children's school space is limited and not optimal. Outside the school environment (residence) also affects the level of motor development of children [7].

The majority of students at leisure or after school hours are widely used for leisure and only a few students who often do physical activity (exercise). In addition, with the development of technology, causing students to use it more excessively, this has become one of the factors causing the low level of students doing physical activities. the habit of children playing games, watching TV [8].

This study only confirms that physical growth and motor development are very influential on the continuity of students in learning physical education and influential in achieving student achievement, for that it needs to be considered in the process of growth and development of children.

4 Conclusion

The conclusion of the study was that physical growth in the fifth grade elementary school in Pituruh District was included in the "normal" category and for the level of motor development included in the "moderate" category.

References

- [1] Ardiansyah, F. (2016). Kemampuan Motorik Dasar Siswa Kelas IV dan V SD N Keraton Yogyakarta Tahun Ajaran 2015/2016. *PGSD Penjaskes*, (6).
- [2] Arikunto, Suharsimin. (2010). *Prosedur Penelitian Suatu pendekatan Praktik*. Jakarta: Rineka Cipta.
- [3] Kementerian Kesehatan. (2010). Keputusan Menteri Kesehatan Republik Indonesia. Jakarta: Direktorat Jenderal Bina Gizi dan Kesehatan Ibu dan Anak, Kementerian Kesehatan RI.
- [4] Mahayaty, L. (2014). Studi Tentang Faktor– Faktor Yang Mempengaruhi Pertumbuhan Dan Perkembangan Pada Balita Di Desa Pengalangan RW 03 Menganti Gresik. *Jurnal Keperawatan*, 3(1).
- [5] Nurhasan, 2000. Tes dan pengukuran pendidikan olahraga. Online available at [https://id.scribd.com/doc/302333652/Tes-Dan-Pengukuran-Pendidikan Olahraga-Drs-Nurhasan-m-pd](https://id.scribd.com/doc/302333652/Tes-Dan-Pengukuran-Pendidikan-Olahraga-Drs-Nurhasan-m-pd).
- [6] Sugiyanto. 2008. *Perkembangan dan Belajar Motorik*. Jakarta: Universitas terbuka.
- [7] Sugiyono. 2010. *Metode penelitian pendidikan*. Bandung: Alfabeta.
- [8] Syarifudin. (2010). *Tes Prestasi Fungsi dan Pengembangan Pengukuran Prestasi Belajar*. Yogyakarta: Pustaka Pelajar.

The Use of Oxytocin Electrostimulator Corsets as A Preventive Measures of Postpartum Bleeding Potential

Ida Ayu Putu Dewi Adnya Suwari¹, Runjati², Djameluddin Ramlan³
 {dayuadnyasuwari@yahoo.com¹, runjati@yahoo.com², djameluddinramlan@gmail.com³}

Poltekkes Kemenkes Semarang, Semarang, Indonesia^{1,2,3}

Abstract. Postpartum hemorrhage can be prevented by administration of oxytocin. However, oxytocin electrostimulator corset was needed to keep uterus contracting effectively because of relatively short half-life of oxytocin. A quasi-experimental research design with time series was conducted at Gunung Sari Health Center, West Lombok, Indonesia on 40 giving birth women by consecutive sampling technique. The study objective was to determine oxytocin electrostimulator corsets effect on 24 hours postpartum maternal blood volume. There were differences in the average blood volume in 6 hours postpartum, 12 hours postpartum, 18 hours postpartum, 24 hours postpartum and total blood volume in 24 hours postpartum between control and intervention group ($p < 0.05$). However, the average bleeding volume was no difference between stage III and 2 hours postpartum. The use of oxytocin electrostimulator corset can reduce maternal blood volume within 24 hours postpartum. This research was expected as reference for the postpartum hemorrhage prevention.

Keywords: corset, electrostimulator, oxytocin, postpartum hemorrhage

1 Introduction

Postpartum hemorrhage is a blood disorder after a 500 ml vaginal delivery[1] that causes an increased risk of infection, Sheehan's Syndrome and even failure of lactation[2–6]. Based on Meng's Chen et al., Research showed that massage to the uterus combined with administration of oxytocin to MAK III care did not give effective added benefits and was not a step needed to prevent postpartum hemorrhage so that midwives could take time for other work[7]. Oxytocin also has a relatively short half-life of 4-10 minutes to keep the uterus steady. Effective contraction requires ongoing intervention[8]. In the research of Anggorowati et al., Showed that oxytocin stimulation can be done using engineered tools such as electrostimulators using Digital Massager of Oxytocin (DMO). DMOs can be practiced on postpartum mothers in any situation as long as they are conscious. DMO tools are simple, can be practiced independently and managed by themselves. The average oxytocin in postpartum women on the first day

given DMO was 353.58 ng / ml and showed that the maternal oxytocin hormone was in the normal category[9]. The use of a tight back corset will put pressure on the abdominal so that when doing the movement will reduce intra-distal pressure to 30%, so that the muscles of the lumbar will be more relaxed, so that spasm is reduced, muscle stability will be achieved.

2 Subjects and Method

2.1 Study Design

This type of research is a quasi-experimental research with a time series research design. This research was conducted in January-February 2020 at the Gunung Sari Health Center in West Lombok.

2.2 Population and Sample

The population in this study were all women giving birth at Gunung Sari Health Center, West Lombok Regency. The sample in this study were mothers who gave birth to vaginal birth at the Gunung Sari Health Center. Determination of the research sample is done by using consecutive sampling which is a way of taking samples by selecting samples that meet the research criteria until a certain period of time so that the number of samples is fulfilled. subject minimally met. Where respondents in odd order are grouped in the intervention group, while respondents in even order are grouped in the control group. The sample in this study was chosen based on the following criteria.

a. Inclusion criteria

- 1) Mothers who are willing to be respondents
- 2) Mother giving birth vaginal
- 3) The mother does not have an allergy to the underpad and pads provided by the researcher
- 4) Mothers whose parity is ≤ 4

b. Exclusion criteria

- 1) Women with complications that cause the need for operative measures such as vacuum, extraction of forceps or sectio caesarea.
- 2) Women who experience complications such as placental retention, uterine atony, uterine inversion, placental rest, uterine tears.

So the sample in the intervention group were 20 samples and the control group were 20 samples so that the total number of intervention and control samples was 40 samples.

2.3 Study Variables

The independent variable in this study was the back corset oxytocin electrostimulator in the intervention group compared with oxytocin message in the control group. While the dependent variable is maternal blood volume 24 hours postpartum.

2.4 Operational Definition of Variables

The oxytocin electro stimulator back corset which is an independent variable is a therapeutic tool for stimulating oxytocin using low-frequency electricity at points BL 17 and BL 18 with a duration of 20 minutes which is packaged simply in the form of a back corset. Blood volume which is the dependent variable is blood volume measured from the third stage of labor until the first 24 hours postpartum. Blood volume is measured by calculating the difference in the wet and dry weight of the blood absorption media, where 1 gram is equal to 1 ml of blood. Weighing blood volume with a digital scale and observing it with SOP's and observation sheets. Blood volume results in ml units with a ratio measurement scale. For age, parity and hemoglobin level, interviews were conducted using a questionnaire.

2.5 Study Instruments

This research was conducted using instruments in data collection such as:

1. Blood volume measuring devices with a digital scale with the brand DNG Kitchen Scale AB 01.
2. Respondent questionnaire that became the study sample.
3. Standard Operational Procedure (SOP) measurement of maternal blood volume 24 hours postpartum by gravimetric method.
4. Observation sheet 24-hour postpartum maternal blood volume measurement results.
5. Oxytocin electrostimulator back corset

The oxytocin electrostimulator back corset was modified from the Multi-Functional Dual-Output Massager Model JY-A818.

2.6 Data analysis

This univariate analysis looks at the frequency distribution of data: age, parity and hemoglobin levels. This analysis takes the form of a frequency distribution and then narrated by the results of research that has been done. The research data were tabulated for further analysis using SPSS for bivariate analysis. Prior to the analysis test, the data normality test was carried out using Sapiro Wilk and to decide the difference in average bleeding at each measurement time interval, the Independent Sample T-Test.

2.7 Research Ethics

This study pays attention to ethical aspects such as Informed Consent, Anonymity, Confidentiality, Equality, Benefecience, Respect of Human Dignity and Justice. This research was conducted after the Ethical Clearance proposed by researchers was approved by the Health Ethics Committee of the Mataram Health Polytechnic Number: LB.01.03 / 1.1 / 906 / 2020 on January 2, 2020.

3 Results

3.1 Sample Characteristics

Table 1. Homogeneity Test Characteristics of Respondents

Variabel	Kelompok		p-value
	Intervensi Mean \pm SD	Kontrol Mean \pm SD	
Age	30,1 \pm 6,42	26,55 \pm 6,32	0,753
Parity	2,60 \pm 1,046	1,90 \pm 0,912	0,275
Hemoglobin Levels	12,05 \pm 0,821	12,03 \pm 0,898	0,402

Based on table 1 about the characteristics of the respondents interpreted in the intervention group that is the most statistically aged at the ideal reproductive age of 20-35 years as many as 16 people (80%), while the control group more than 20-35 years as many as 17 people (85%). On parity characteristics, multiparity tended to be higher than primary found 17 people (85%) in the intervention group while the control group 12 people (60%). For the characteristics of dominant hemoglobin, respondents had HB 11-11.9% with a well-balanced number of 11 people (55%) in the intervention and control groups.

Based on table 1 the average age is 30.1 years, parity 2 to 3 and Hb level is 12.05 gr%. The frequency distribution of the characteristics of the control group had an average age of 26.5 years, an average parity of 1 to 2 and a Hb level of 12.03 gr%. After the levene test was carried out on the characteristics of age, parity and Hb levels, p-value > 0.05 means that the respondents of the two research groups were homogeneous, so it can be concluded that there were no differences in characteristics between the two groups.

3.2 Bivariate Analysis

Data normality test results of measurement of bleeding volume using Shapiro-Wilk due to the number of respondents <50, a data distribution is said to be normal if the value of $p > 0.05$. This normality test uses SPSS version 16. Results of normality test data on total blood volume 24 hours postpartum on the third stage measurement, 2 hours postpartum, 6 hours postpartum, 12 hours postpartum, 18 hours postpartum, 24 hours postpartum and total blood volume and the difference in each measurement obtained p-value significance value > 0.05 or normal distribution of data distribution, so to test the hypothesis used the Independent Sample T-Test. However, the measurement of 6 hours postpartum obtained a significance value of 0.015 (p-value < 0.05) or distribution of data that was not normally distributed, then carried out a transformation of the data and obtained a significance value of 0.210 (p-value > 0.05) or normal distribution data so parametric test is carried out using the Independent Sample T-Test as well. To compare the p-value of the bleeding volume between each group, the Independent Sample T-Test was performed which has been described in the table. In addition, it can be seen that maternal blood volume at 6 hours postpartum, 12 hours postpartum, 18 hours postpartum, 24 hours postpartum, and total maternal blood volume in 24 hours

postpartum in the intervention and control groups obtained p values <0.05 , which means H_0 rejected. It can be concluded that there are differences in average maternal blood volume at 6 hours postpartum, 12 hours postpartum, 18 hours postpartum, 24 hours postpartum, and total maternal blood volume in 24 hours postpartum between the intervention group given the back corset oxytocin electrostimulator with the control group provided given oxytocin massage. The volume of bleeding in mothers who were given the back corset oxytocin electrostimulator had lower mean bleeding than those who were given oxytocin massage on each measurement. Measurement of maternal blood volume at stage III, 2 hours postpartum and the difference between the results of each measurement time interval obtained p value > 0.05 , which means there is no difference in the decrease in maternal blood volume between the intervention group and the control group at stage III, 2 hours postpartum and the difference the results of each measurement time interval. The results of the measurement of bleeding volume in the first 24 hours postpartum in the intervention and control groups can be seen in Figure 4.1.

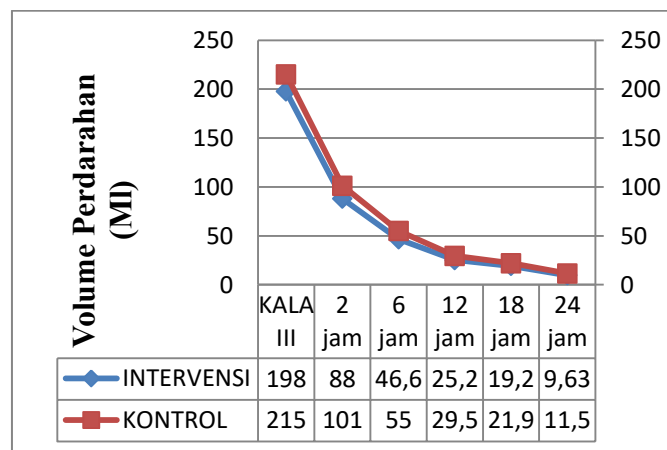

Fig. 1. Comparison of 24-hour bleeding volume Postpartum in the Intervention Group and Control group

Based on graph 4.1 above, it can be seen that the volume of bleeding in both groups experienced a significant downward trend starting from 2 hours postpartum and continuing to decrease to 24 hours postpartum. The average blood volume in the control group was higher than the average blood volume in the intervention group in each measurement. Blood volume tends to have a trend that decreases slowly until the next measurement.

The average total bleeding volume in the intervention group was 386.03 ml with a minimum volume of 311.47 ml and a maximum of 468.99 ml. The intervention group had lower average bleeding than the control group at each measurement. In the control group the average total bleeding volume was 434.25 ml with a minimum volume of 327.81 ml and a maximum of 507.78 ml. The bleeding volume at the first measurement is the most bleeding volume compared to the bleeding volume at other

observation time intervals because the bleeding originates from the placental implantation site.

At 2 hours postpartum, the bleeding volume was reduced to 55.46% from the measurement at the third stage in the intervention group. Bleeding volume tends to experience a significant decrease in stage III towards 2 hours postpartum. At the next measurement at 6 hours postpartum, blood volume was reduced in the range of 47.07% from the previous measurement at 2 hours postpartum. At 12 hours blood volume was reduced in the range of 45.90% from measurements at 6 hours postpartum and at 18 hours blood volume was reduced at around 23.74% from previous measurements at 12 hours postpartum. At 24 hours postpartum bleeding decreased to 49.84% from the previous measurement in the intervention group.

The bleeding volume also continued to decrease slowly in the control group. At 2 hours postpartum, the bleeding volume decreased to 52.96% from the time of the third stage in the control group. Bleeding volume tends to experience a significant decrease in stage III towards 2 hours postpartum. At the next measurement at 6 hours postpartum, blood volume was reduced in the range of 45.66% from the previous measurement at 2 hours postpartum. At 12 hours blood volume was reduced in the range of 46.33% from measurements at 6 hours postpartum and at 18 hours blood volume was reduced considerably in the range of 25.66% from previous measurements at 12 hours postpartum. At 24 hours postpartum bleeding was reduced by 47.69% from the previous measurement in the control group.

The trend of blood volume in both groups has decreased. Blood volume continues to decrease slowly until the next measurement. This can be seen from the calculation of the difference in the measurement of blood volume at each time interval of observation. In the difference between the first measurement ie stage III and 2 hours postpartum there was a decrease in blood volume which was very much around 55.46% in the intervention group and 52.96% in the control group and in the 18 hours and 24 hours postpartum there was a decrease in blood volume around 49.84 % in the intervention group and 47.69% in the control group. It can be concluded that the greatest decreasing trend in bleeding is in the intervention group given the back corset oxytocin electrostimulator.

4 Discussion

In this study, $p\text{-value} > 0.05$ showed that there was no difference in the average bleeding volume at stage III, 2 hours postpartum and the difference in blood volume at each interval of measurement time. At the time of the first measurement, the bleeding volume was relatively more than the following measurements because the blood vessels which were the source of bleeding were still open and in the third stage both the intervention group and the control group had not been given any intervention. As explained earlier that the source of bleeding in the normal delivery process comes from the former site of placental implantation and laceration of the birth canal which makes the two groups have an average blood volume that is not much different.

The average amount of bleeding after the placenta was given an injection of oxytocin was 185.5 ml while the amount of bleeding that was not given oxytocin injection

was 229.5 ml. In this study the amount of bleeding during the third stage in the intervention group was 197.5 ml and the control group was 215.1 ml, where both groups were given oxytocin injection. The study of 10 women showed an increase in plasma oxytocin concentration after being given oxytocin at the time of birth of the placenta. In stage III there is a sudden reduction in metabolism due to the release of the placenta, where the placenta is the main source of oxytocin. As a result of the release of the placenta, the hypothalamus is stimulated to produce the hormone oxytocin. In addition, the hormone oxytocin can be produced through stimulation of oxytocin stimulation, one of which is by electrostimulator[10].

In this study blood volume at 2 hours postpartum obtained an average of 87.96 ml intervention group and 101.17 ml control group. There was no significant difference in maternal blood volume 2 hours postpartum between the intervention and control groups. This is because in the second measurement, the opened blood vessels have closed with uterine contractions and also stitching of the birth canal tear. As a result, there is a very significant decrease in bleeding volume in this second measurement. Naturally, the uterus will undergo a process called uterine involution in which the size of the uterus will gradually shrink in reference to its original size before pregnancy. This involution process occurs by making the uterus contract so that the opened blood vessels from the placental release gradually close and the bleeding decreases. The effectiveness of uterine contractions needs to be maintained because bleeding can occur at any time.33 This is in line with Chilmawati's[3] study that the amount of bleeding that is considered normal at stage 4 is 250 ml, usually 100-300 ml. This theory is strengthened by the results of Sarli et al's[11] study which states that the average amount of bleeding is 247.06 ml and Rahmawati's study was 252.50 ml in the control group who did not get any intervention at 2 hours postpartum[12].

In this study the results of blood volume measurement based on measurement time at 6 hours postpartum, 12 hours postpartum, 18 hours postpartum, 24 hours postpartum and total bleeding for 24 hours obtained p value <0.05 which means that there are differences in all measurements in the intervention group and control group. Bleeding that was considered normal in the first 6 hours of postpartum was 1 bandage or as many menstrual blood came out.8 In this study blood volume in the intervention group was 46.55 ml and 54.97 ml in the control group so the bleeding volume was still considered normal. In addition, it was also obtained the difference in value based on the time of measurement in each group where in the second measurement difference ie from 2 hours and 6 hours postpartum there was a very large decrease in blood volume around 55.46% in the intervention group and 52.96% in the group control. At measurements at 12 hours, 18 hours and 24 hours the volume of bleeding tends to decrease consistently at subsequent measurements. At 12 hours blood volume was reduced by a range of 45.90% from the 6 hour postpartum measurement and at 18 hours blood volume was reduced at around 23.74% from the previous measurement at 12 hours postpartum in the intervention group while for the control group at 12 hours the blood volume was reduced in the range of 46.33% from the measurement at 6 hours postpartum and at 18 hours the blood volume was reduced considerably in the range of 25.66% from the previous measurement at 12 hours postpartum. The reduction in blood volume is less because of 40 respondents there were 3 respondents in the intervention group and 3 respondents in the control group who experienced an increase in bleeding volume from 12 hours to 18 hours.

An increase in the volume of bleeding in women who received standard care at certain observation time intervals even though it was not significant. Postpartum hemorrhage that causes death is not always bleeding at once in large quantities but can occur little by little but continuously the amount sometimes does not cause suspicion. Three out of five cases of maternal death due to bleeding are caused by suboptimal routine observations during the puerperium, therefore, the patient needs to be observed closely, appropriate action is taken immediately and the diagnosis is made early[8].

At 24 hours postpartum bleeding decreased to 49.84% from the previous measurement in the intervention group and reduced to 47.69% from the previous measurement in the control group. This shows that the application of the oxytocin electrostimulator back corset can reduce the volume of postpartum hemorrhage because it is able to keep the uterus contracting effectively as research results by Anggorowati et al., Which states that the average oxytocin in postpartum women on the first day is 353.58 ng / ml engineered oxytocin stimulation such as Digital Massager of Oxytocin (DMO) shows that the maternal oxytocin hormone is in the normal category[10]. In addition, 24 hours postpartum the mother has mobilized to facilitate blood flow into the uterus so that uterine contractions will be good and uterine fundus will become hard and smooth out blood and residual placenta. Where early mobilization is an immediate activity that is carried out as soon as possible after a few hours of rest by moving from the mother's bed in normal labor.

The average total bleeding volume in the intervention group that was given an oxytocin electrostimulator back corset was 386.03 ml with a minimum bleeding volume of 311.47 ml and a maximum of 468.99 ml. The average total bleeding volume in the control group was 432.25 ml with a minimum bleeding volume of 327.81 ml and a maximum of 507.78 ml. The intervention group had an average lower total bleeding volume than the control group that could be affected by the respondent's age, parity and Hb levels at delivery.

Based on table 4.1 regarding the characteristics of respondents interpreted in the intervention group has an average age of 30.1 years and the control group has an average age of 26.5 years. Age at risk (<20 years or> 35 years) has a 3.7 times greater risk of experiencing postpartum hemorrhage than mothers who are not at risk (20 to 35 years). The safest age is between 20 - 35 years because at that time the woman was in a healthy reproductive period [13]. In addition, in this study the average parity in the intervention group 2 to 3 and the control group had an average parity of 1 to 2. The magnitude of risk 2 , 4 times greater parity at risk (1 or> 3) to experience postpartum hemorrhage than parity at no risk (2 - 3) [13]. Parity greater than 4 has uterine muscle stretched more frequently so that the walls are thinner and contractions are weaker [14]. Mothers giving birth with Low Hb can decrease Hb faster if bleeding occurs. In this study, the average Hb level was 12.05 gr% in the intervention group and the Hb level was 12.03 gr% in the control group. Anemic maternal women have a risk of 17.6 times for postpartum hemorrhage compared to mothers who are not anemic because of uterine disability which is a direct cause of atonia [15].

This study is in line with the results of Diah et al's study in which 24-hour total bleeding volume in the 509.80 ml intervention group was given acupressure and moxibustion while 596.65 ml in the control group was only given acupressure only. However, the results of his study show that the combination of acupressure and moxibus-

tion can reduce the volume of blood loss at each interval of observation but cannot prevent postpartum hemorrhage that occurs immediately after birth of the placenta [8].

In addition, the difference in decrease in blood volume with a p -value > 0.05 was obtained which showed no difference in the decrease in blood volume between the intervention group and the control group at each time interval of measurement. Where the intervention group had a difference in a decrease in blood volume higher than the control group. However, the uterus will naturally undergo a process called uterine involution in which the size of the uterus will gradually shrink to its original size before becoming pregnant. This involution process occurs by making the uterus contract so that the blood vessels that open due to the release of the placenta gradually close and the bleeding decreases. The effectiveness of uterine contractions needs to be maintained because bleeding can occur at any time [8].

Massage stimulation using an electrostimulator back corset will trigger contraction of smooth muscle in the uterus. Actin and myosin bonds are strengthened by the release of the hormone oxytocin so that uterine contractions get stronger and the process of uterine involution is better. The hormone oxytocin compresses blood vessels and helps the process of hemostasis. The contractions and retractions of the uterine muscles also reduce the blood supply to the uterus. This process helps reduce placental implantation scars and reduces bleeding [16]. Back corsets are also able to support the back and abdominal muscles after pregnancy and offer comfort to the mother, help shrink the uterus, pull back the abdominal wall muscles and reduce the space for fat deposits. Postpartum mothers who wear corsets can get a little compression in the abdominal transversus muscle so that it supports the abdomen and lumbopelvic region [17].

The results of this study are in line with research conducted by Cunningham that the abdominal wall muscles function as a stabilizer (brace) so that the force reaching the abdominal wall will be reflected back and will increase intra-abdominal pressure and then will increase the thrust into the uterine cavity. This is what drives lochea fluid out through the vagina, a decrease in the uterine fundus and a good uterine involution process [18]. In addition, the back corset oxytocin electrostimulator uses a spike-exponential monophasic pulse shape having an effective voltage that is much smaller than its peak voltage. This causes the effective current produced by the electrostimulator to be small, so that it can meet the safety standards of medical instrumentation [19]. In addition, this tool has a DC voltage of 4.5 volts which is included in the normal range because at this voltage the impulse response is relatively stable [20] because when the energy level is given above the threshold energy there is an overall action potential, but if the energy is below the threshold energy there is no action potential [13].

On the back corset the oxytocin electrostimulator frequency setting is related to the purpose of the use of electrostimulator [20]. The recommended setting that can be used is the high frequency of 100 Hz [21], and this tool has a frequency of 1-330 Hz which can be adjusted according to patient needs. This electrostimulator also complies with medical device safety standards by having an effective current below 5 mA because the higher the amplitude given means that also increases the electrical energy sent into the body [19].

5 Conclusion

The use of oxytocin electrostimulator back corset as an effort to prevent the potential for postpartum hemorrhage that has been described, it can be concluded that there are differences in maternal blood volume at 6 hours postpartum, 12 hours postpartum, 18 hours postpartum, 24 hours postpartum and total blood volume in 24 hours postpartum in the intervention group and the control group with a p-value <0.05 with the average blood volume of the intervention group lower than the control group at each measurement time interval.

6 Financial Support and Sponsorship

There was no financial support and sponsorship.

7 Conflict of Interest

The authors state explicitly that there are no conflicts of interest to be disclosed.

Acknowledgement We would like to thank Postgraduate Applied Science Program in Midwifery, Poltekkes Kemenkes Semarang.

References

- [1] Lutomski JE, Byrne BM, Devane D, Greene RA. Increasing trends in atonic postpartum haemorrhage in Ireland: An 11-year population-based cohort study. *BJOG An Int J Obstet Gynaecol* 2012;119:306–14.
- [2] Maria R, Volpato J, Asse P, Luzi E, Asse V, Fernanda M et al. Components of breast milk. *J Matern Neonatal Med* 2013;26:1223–7.
- [3] Chilmawati L, Pradjatmo H, Siswosudarmo HR. Pengaruh pemberian asam traneksamat terhadap jumlah perdarahan pascasalin pada kelahiran vaginal. *J Kesehat Reproduksi* 2014;1:98–102.
- [4] Abdul-Kadir R, McLintock C, Ducloy AS, El-Refaey H, England A, Federici AB, et al. Evaluation and management of postpartum hemorrhage: Consensus from an international expert panel. *Transfusion* 2014;54:1756–68.
- [5] Wang F, Li C, Li S, Li Q. Integrated interventions for improving negative emotions and stress reactions of young women receiving total hysterectomy. *Int J Clin Exp Med* 2014;7:331–6.
- [6] Karaca Z, Laway BA, Dokmetas HS, Atmaca H, Kelestimur F. Sheehan syndrome. *Nat Publ Gr* 2016;2:1–15.
- [7] Chen M, Duan T. Uterine massage to reduce blood loss after vaginal delivery 2013;122:290–5.
- [8] Mesayu diah kurniawati. Efektivitas akupresur dan moksibusi terhadap penurunan perdarahan dalam 24 jam pertama pascasalin. poltekkes kemenkes semarang, 2019.
- [9] Anggorowati A, Sutadi H, Setyowati S, Koestoer RA. Effects of acupoint stimulation with digital massager of oxytocin on the breast milk production of working mothers.

- Nurse Media J Nurs 2017;6:91.
- [10] Anggorowati A, Susilowati D, Zubaidah. Effects of engineered stimulation of oxytocin on hormonal status of postpartum women. *Hiroshima J Med Sci* 2018;67:91–6.
- [11] Sarli D, Agus M. Artikel penelitian pengaruh perbedaan kadar oksitosin melalui pemijatan oksitosin terhadap jumlah perdarahan pada ibu 2 jam postpartum. *J Kesehatan Andalas* 2014;4:743–50.
- [12] Rahmawati WR, Arifah S, Widiastuti A. Pengaruh pijat punggung terhadap adaptasi nyeri persalinan fase aktif lama kala II dan perdarahan persalinan pada primigravida. *Kesmas Natl Public Heal J* 2013;8:204.
- [13] Ummah N, Ngadiyono N, Ulfiana E. Faktor resiko penyebab perdarahan postpartum di puskesmas pamotan kabupaten rembang. *J Kebidanan* 2018;7:39.
- [14] Yekti Satriyandari NRH. Faktor-faktor yang mempengaruhi kejadian perdarahan postpartum. *J Heal Stud* 2014;1:49–64.
- [15] Psiari Kusuma W. Faktor-faktor yang mempengaruhi terjadinya perdarahan postpartum. *J Ilmu Kesehat* 2017;2:51–60.
- [16] Meintri Lanasari N, Rahayu S, Panggayuh A. Pengaruh pijat endorfin terhadap percepatan involusi uteri pada ibu nifas post sectio caesarea. *J Ilm Bidan* 2018;III:15.
- [17] Benjamin DR, van de Water ATM, Peiris CL. Effects of exercise on diastasis of the rectus abdominis muscle in the antenatal and postnatal periods: A systematic review. *Physiother (United Kingdom)* 2014;100:1–8.
- [18] Sumarah, Mohammad Hakimi SP. Pengaruh inisiasi menyusui dini terhadap jumlah perdarahan pasca persalinan. *J Kesehat Reproduksi* 2014;1:60–9.
- [19] Hutomo AP, Astuti SD. Rancang bangun sistem pengendali tegangan stimulasi elektrostimulator otomatis berbasis resistansi tubuh. *J Biosains Pascasarj* 2018;20.
- [20] Evrita LU, Irawadi B, I Made GGP. Simulasi alat elektrostimulator akupuntur berbasis mikrokontroler ATMega16. *J Ilmiah, Tek Elektro, Fak Sains Teknol Univ Respati Yogyakarta, Yogyakarta* 2017;23:29–42.
- [21] Báez-Suárez A, Martín-Castillo E, García-Andújar J, García-Hernández JÁ, Quintana-Montesdeoca MP, Loro-Ferrer JF. Evaluation of different doses of transcutaneous nerve stimulation for pain relief during labour: A randomized controlled trial. *Trials* 2018;19:1–10.

Developing Mobile Apps Technology to Improve Student Performance in Physical Education

Ipang Setiawan¹, Wahyu Ragil Kurniawan², Dwi Gansar Santi Wijayanti³,
Bhayu Billiandri⁴

{Ipang_setiawan@mail.unnes.ac.id¹, wahyuragil@mail.unnes.ac.id²,
dwigansarsanti@mail.unnes.ac.id³}

Universitas Negeri Semarang, Semarang, Indonesia^{1,2,3,4}

Abstract. The purpose of this study is in order to respond to universal challenges to discuss effective assessment designs by utilizing new technologies in physical education. This study was conducted on PE teachers, students, and parents, by taking into account their experiences in using application products. The methods used to support the development process: (1) Determine content; (2) choose an apps platform; 3) Design product; (4) Test the Prototype. Results in this study are the design of mobile application products to improve students in physical education lessons. The prototype was evaluated by parents, students, and PE teachers as users. Conclusion is smartphone applications may be an innovative medium for intervening in change and students' abilities in learning physical education. This research can be made as a basic for further research to create a mobile application in physical education.

Keywords: mobile application, learning outcomes, physical education, authentic assessment

1 Introduction

Mobile technologies are one of the most popular things today. Various groups ranging from workers until students have used it. However, there are still many teachers who do not yet know about how mobile technologies can affect the learning outcomes. This will be a big problem if not addressed, because the teaching practice of teachers is greatly influenced by their understanding and skills [1]. Providing an authentic assessment is one of the huge problems that are still faced by physical education teachers. How to determine the learning objectives have been achieved, what competencies that students must master in physical education, until how they must provide continuous and appropriate assessment to students, are problems that must be resolved by physical education teacher[2]. Assessment that refers to the process is very important because the teacher can see how students are able to make decisions and assess the best performance in every material they learn.

giving feedback is very important in achieving the learning outcomes [3]. However, there are some problems that still faced by PE teacher, there are: teacher cannot provide feedback directly to students at the time, cannot easily report student learning outcomes to parents or other teachers, and the teacher also cannot access student performances in class regularly. Some alternative tools and systems databases can do this work for now, but it is not simple enough. A laptop with size that is less practical if brought while teaching in the field. Therefore, teachers usually use a basic list first on paper then send data to the system later. This makes the process slow and inefficient[3]. Some studies have tried to promote a model for evaluating learning outcomes and giving feedback through technology, by integrating instruments and needs analysis in the field.

Technology plays a role as a tool in education, to advance the relationship between students and educators, reduce the gaps associated with finding support resources in learning, and technology also greatly helps meet the needs of students [4]. To compete in this century, teachers must be able to keep abreast of technological developments by being able to create, grow, and be able to use innovative mobile technology, to make education more sophisticated and modern accessible to anyone and at any time. [5]. Very important to know, because an effective Learning environment with technology is created by people, not technologies. Teachers and students who are aware of this development then will issue and want to use it, so they can change and enhance their educational experience in the current era of technological development [6].

Mobile application technology is not only used to achieve maximum learning outcomes, but also used as a provider of data information available at any time. Mobil application technology is considered as a practical and easy alternative to carry anywhere. Related with the description, this study supports to overcome the problem by supporting mobile applications to improve learning outcomes. Practically, found in the MGMP Junior High School, Physical Education teacher association. With detailed procedures, the prototype was tested, while its validation was carried out by the questionnaire filling method. This study will consider case study research where the research will be the basis for further improvement and development.

2 Related Studies

2.1 Developing a digital assessment in senior secondary physical education

This study was conducted to inform the development of Physical Education in Western Australia incorporating practical and / or performance dimensions. This research investigates various types of authentic digital assessments that can be improved for implementation across countries in an easy and inexpensive way. the purpose of this study is to provide insight into physical education teachers to be able to design authentic assessment tasks to be able to see student achievement. The result of this study, students like the way in which the 'practical' and 'theoretical' aspects are combined in the assignments given by the teacher in physical education. PE teacher agrees to be able to design authentic assessment tools that are in line with the teacher's pedagogical abilities. and the tools expected to be able to assess students' knowledge and skills. [2].

2.2 Development of Smartphone Applications for Nutrition and Physical Activity Behavior Change

This study discusses four applications that aim to modify lifestyle behaviors associated with weight gain, physical activity, and consumption of foods, fruits, vegetables, and drinks with sugar sweeteners. Requires 18 months to develop this application. after it was finished, the application was tested on 10 subjects, and various responses were obtained including the slow speed of the application network due to the dependence on the Internet connection which was the main problem identified by the research team. Smartphone applications can be an alternative tool that can change a person's healthy behavior, while still paying attention to the number of subjects tested and the strength of the network connection, as well as the app's feasibility to be used for a long period. [7].

2.3 Instructional Tools for Online Physical Education: Using Mobile Technologies to Enhance Learning

The results of this study, explained that the use of applications or technology in education has not fully reached the point of maximum benefit, instead it gave rise to negative results. one of them is the lack of an effective and efficient system. so It is necessary to become a particular focus of future researchers, that how to design a technology application that can indeed provide an effective and efficient element is very important. do not let the application developed in the context of physical activity, it actually causes the saturation of the students in their activities. so there needs to be a synchronization between the concept of content, and the expected outputs in designing an application concept in terms of observing a person's behavior or physical activity. [8].

3 Research Design

Design and development are used in this study. We define this research as a "systematic study of the design, development and evaluation process with the aim of establishing an empirical basis for creating new and improved learning products and tools as well as models that govern the development of learning systems especially in physical education." [9]. The questionnaire through the Google form is used to collect data filled in by users or test subjects. This questionnaire is used to discuss the opinions of physical education teachers, students and parents on the use of smartphones and the design of mobile applications to support physical education learning. Descriptive statistics are used to illustrate participants and design the applications they will use. Describing quantitative data done to explore the perspectives of physical education teachers, students, and parents perspectives on the mobile way applications that support student learning and the best ways to apply in practice [10].

3.1 Context of the study

This focuses study is the developing application design that can be used as an alternative assessment and feedback tool in physical education. The design created includes all domains that exist in physical education, namely cognitive, affective, and psychomotor. The focus of this study is to develop a prototype design of physical education assessment and feedback applications, and test the prototype to users, there are; physical education teachers, students, and parents. The main factor that is the flagship of this prototype is the involvement of communication between teachers, students, parents, and the completeness of the cognitive, affective, and psychomotor domains that are in one hand. The expected research results are the existence of support and positive responses from users to be able to realize the prototype to the next research in the future

3.2 Participants

Participant tests were occurred in two phases. The initial phase ; 15 PE Teachers in 15 different junior high schools in Semarang City, Central Java, Indonesia. 15 students from grade 7,8, and 9, and 15 parents. Initial testing is carried out to correct usability problems with the initial design, by asking participants to try the prototype and carry out the basic tasks that have been set in it. Then they provide comments and suggestions via the Google form provided. Then apps modified based on suggestion and evaluation from the first test. While the second phase, a retrial was conducted on 30 PE teachers, 30 students, and 30 parents. By providing a prototype link for use the prototype, and all of the participants would give an evaluation, suggestion, also comments using google form provided

3.3 Procedure and survey instrument

The methods used to support the development process: (1) Determine content; (2) choose an apps platform; 3) Design product; (4) Test the Prototype

Stage 1: Determine content

The first stage of this process involves defining the purpose of this application. This is needed to determine what is relevant to assessment and evaluation in physical education, specific strategies for cognitive, behavioral, and performance change, visual or graphic design, and potential data to be collected such as: curriculum, quizzes for cognitive evaluation, indicators behavior, and skills that must be mastered by students.

Stage 2: Choose an apps platform

Second stage, the selection platform to be used in this product. This is based on the majority of user resources in the Semarang, Central Java, Indonesia. Generally they are familiar and exist in using android smartphones. Ease to use is a priority, then based on surveys, application design platforms that are used is android.

Stage 3: Design product

The design focused on ease to use and minimize color combination. BESCOPER is the name of the design apps developed in this study, the elements in it are the three domains of physical education; Cognitive, Affective, and Psychomotor.

Following are the appearance designs and contents of BESCOPER apps:



Fig.1. Display login menu



Fig.2. Optional menu



Fig.3. Display of Quiz (cognitive)

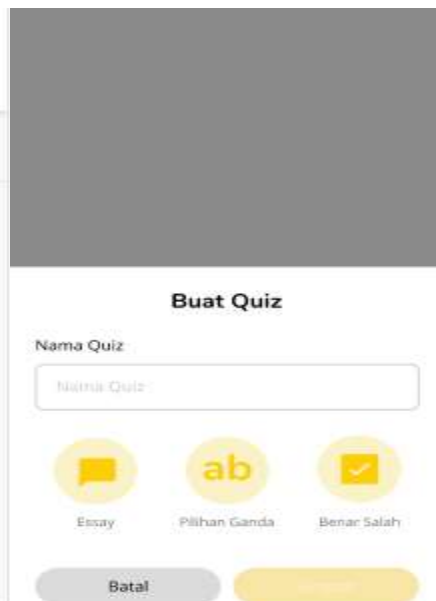

Fig.4. Optional type of Quiz

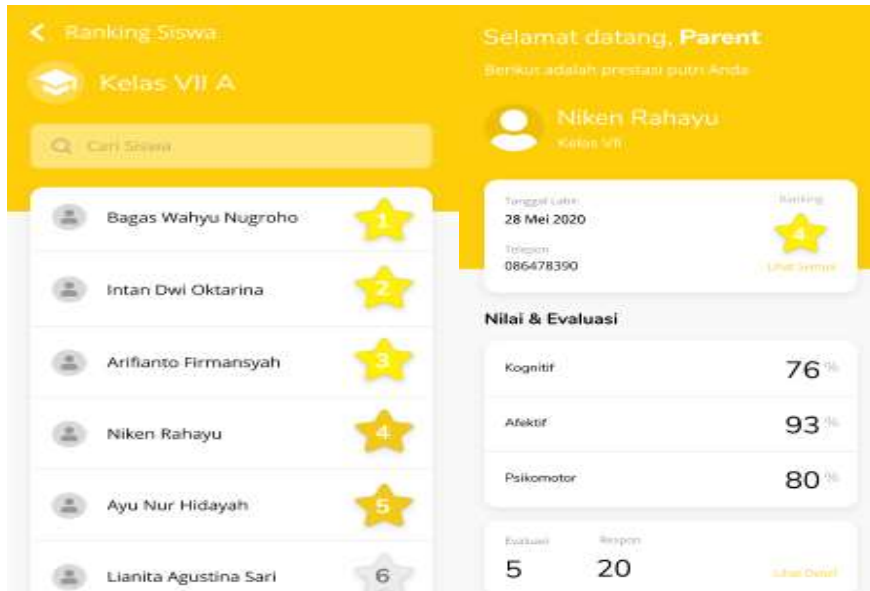

Fig.5. Ranking System

Fig.6. Display for Parents Account

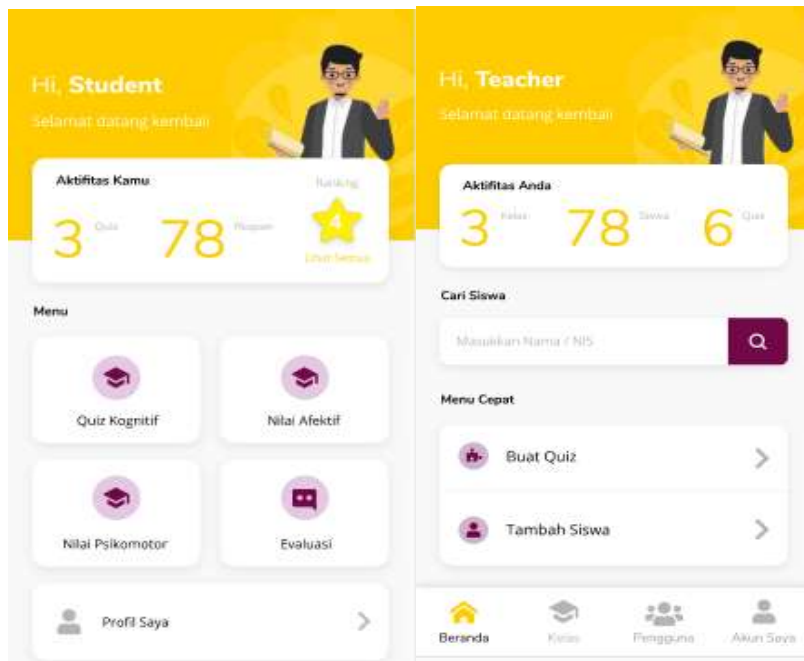

Fig.7. Display for Students Account

Fig.8. Display for Teachers Account

Stage 4: Test the Prototype

Testing the prototype is carried out by sending the prototype link to the participants and sending a google form link to get an assessment from the participants regarding the usefulness of the design that was made. The following is a list of questions used in data collection:

Questions for PE Teachers:

- 1) BESCOPER helps teachers provide assessments to students
- 2) BESCOPER helps teachers evaluate learning activities
- 3) BESCOPER can save the data on the student performance in terms of knowledge, behavior, and skills in physical education
- 4) BESCOPER makes it easy for teachers to give reports of student learning outcomes to parents
- 5) Easy to use
- 6) Interest in using BESCOPER

Question for students:

- 1) BESCOPER makes it easy to see learning outcomes
- 2) BESCOPER facilitates learning in physical education
- 3) BESCOPER improves the mastery of knowledge, attitudes, and skills
- 4) BESCOPER helps communication with teachers and parents
- 5) Easy to use
- 6) Interest in using BESCOPER

Question for parents :

- 1) BESCOPER helps see children's learning outcomes
- 2) BESCOPER facilitates children's learning
- 3) BESCOPER controls children's learning outcomes
- 4) BESCOPER helps communication with teachers
- 5) Easy to use
- 6) Interest in using BESCOPER

Each question has a rating scale range from 1 - 5:

- 1: Strongly Disagree
- 2: Disagree
- 3: Neutral
- 4: Agree
- 5: Strongly Agree

In addition, participants were also given the opportunity to provide suggestions related to the development of prototype in the future in order to become a suitable application to use.

4 Result

The apps design took 2 months including creating a basic database, entering a behavior change strategy, including all physical education materials in accordance with the national curriculum for junior high school, design selection, and the platform used up to the prototype testing stage. Here are the results of the first stage test:

Table 1. PE Teacher Response on Phase 1 (n=15)

Quest	RANGE SCORE					Percentage Value					
	1	2	3	4	5	SD	D	N	A	SA	
1			4	6	5				27%	40%	33%
2			3	7	5				20%	47%	33%
3			3	8	4				20%	53%	27%
4			4	6	5				27%	40%	33%
5			4	5	6				27%	33%	40%
6			4	8	3				27%	53%	20%
Average									25%	44%	31%

Table 2. Students Response on Phase 1 (n=15)

Quest	RANGE SCORE					Percentage Value					
	1	2	3	4	5	SD	D	N	A	SA	
1			4	5	6				27%	33%	40%
2			3	7	5				20%	47%	33%
3			4	6	5				27%	40%	33%
4			4	6	5				27%	40%	33%
5			3	7	5				20%	47%	33%
6			3	7	5				20%	47%	33%
Average									24%	42%	34%

Table 3. Parents Response on Phase 1 (n=15)

Quest	RANGE SCORE					Percentage Value					
	1	2	3	4	5	SD	D	N	A	SA	
1			3	7	5				20%	47%	33%
2			3	8	4				20%	53%	27%
3			4	5	6				27%	33%	40%
4			4	6	5				27%	40%	33%
5			4	5	6				27%	33%	40%
6			3	8	4				20%	53%	27%
Average									24%	43%	33%

The following are the results of the prototype user response in phase 1 :

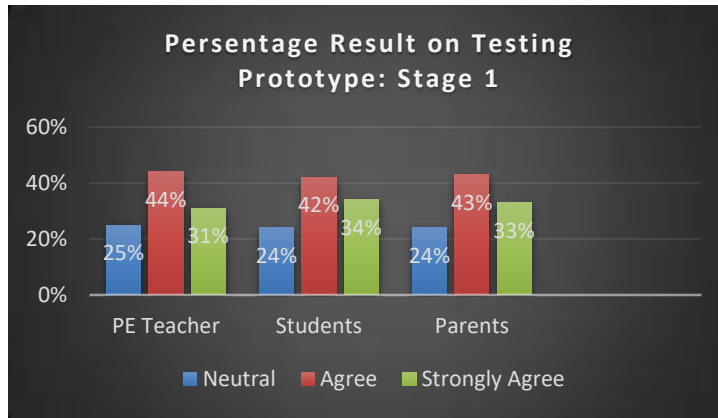

Fig.9. Percentage Result on Phase 1 (Strongly Agree: get average in 33%)

Based on the results of the Phase 1 test, the highest scores on the Phase 1 test only reached 31% from teachers, 34% from students, and 33% from parents. These results need to be improved in the Phase 2 test with modifications previously made according to the suggestions of users in the Phase 1 test. Following are the results of the data obtained after the Phase 2 test:

Table 4. PE Teacher Response on Phase 2 (n=30)

Quest	RANGE SCORE					Percentage Value					
	1	2	3	4	5	SD	D	N	A	SA	
1			3	7	20				10%	23%	67%
2			2	10	18				7%	33%	60%
3			4	15	11				13%	50%	37%
4			1	11	18				3%	37%	60%
5				12	18					40%	60%
6				8	22					27%	73%
Average									5%	35%	60%

Table 5. Students Response on Phase 2 (n=30)

Quest	RANGE SCORE					Percentage Value					
	1	2	3	4	5	SD	D	N	A	SA	
1				12	18					40%	60%
2			1	11	18				3%	37%	60%
3			2	10	18				7%	33%	60%
4				10	20					33%	67%
5				5	25					17%	83%
6				5	22					17%	83%
Average									1%	30%	69%

Table 6. Parents Response on Phase 2 (n=30)

Quest	RANGE SCORE					Percentage Value					
	1	2	3	4	5	SD	D	N	A	SA	
1			1	11	18				3%	37%	60%
2			3	7	20				10%	23%	67%
3			1	11	18				3%	37%	60%
4			2	10	18				7%	33%	60%
5			4	11	15				13%	37%	50%
6				10	20					33%	67%
Average									6%	33%	61%

The following are the results of prototype user response in phase 2 :

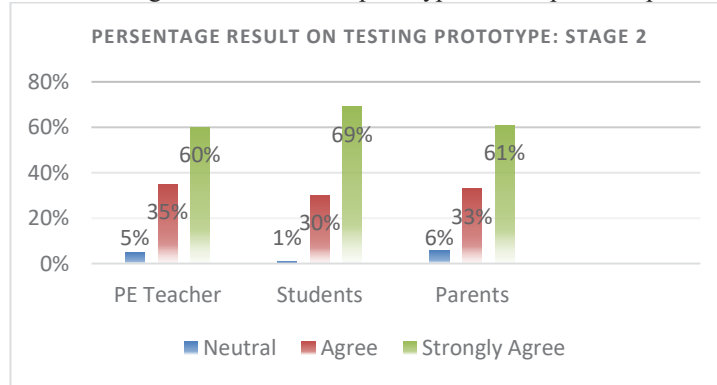

Fig.10. Percentage Result on Phase 2 (Strongly Agree: get average in 63%)

Based on the data result phase 2, it was found that there were changes in the response of users and user ratings of prototype design became more visible. From these results it was found that user responses from stage 1 experienced an increase in ratings in stage 2, with the following explanation:

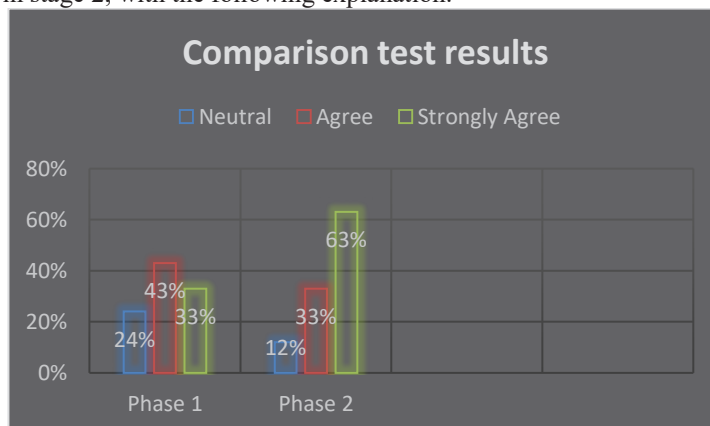

Fig.11. Comparison test results from phase 1 and 2 (Strongly Agree has increase 30%)
 it can be concluded that the users considered the development of BESCOPER prototype are very useful and could be a new research in the future, especially regarding the assessment of student learning outcomes in physical education for junior high schools, because it was felt to be very helpful to teachers, students and parents in monitoring student's learning outcomes at school. This study was answers the world's challenges that the physical education assessment process can be carried out by developing various types of online-based models. Proven from this prototype test results found of support, positive responses, and hopes to be able to use this application are at 63% in "Good" criteria.

5 Conclusion

Based on these results, it can be concluded that users including physical education teachers, students, and parents strongly support the development of prototypes, and they need that. the importance of monitoring the process of student development in learning physical education, especially in the cognitive, affective, and psychomotor domains, and ensuring that students achieve learning goals is the primary basis for users to support this research. The results showed that the interest of users to be able to use this application design is very high, as one of the media for evaluation and assessment of physical education that refers to the development of cellular technology.

6 Suggestion

All activities, testing and data analysis on this study, are makes the researcher be able to offer suggestions: Developing prototype for student performance in achieving physical education learning goals, is very important to do, because of seeing the interests and responses of physical education teachers, students and parents that are interested in to use Android-based application products, or similar cellular technologies. In addition, from the results of this study, the research team found that the BESCOPER design could support the subsequent development of research stages to become a multipurpose application in the future.

Acknowledgements This study collaborates with CV. Edukreasi in focus of educational application developers, handled by Iwan Afandhi Yusuf, who directly handled the database processing and prototype design to be developed. This research is also based on the licensing of the Semarang City Education Office, because this research involves several physical education teachers who are members of the junior high school physical education MGMP teacher, Semarang City. All of participants who have helped this research include junior high school students in several schools in the city of Semarang, and parents with entire research team has collaborated to achieve the implementation of this study.

References

- [1] Domingo MG, Garganté AB. Exploring the use of educational technology in primary education: Teachers' perception of mobile technology learning impacts and applications' use in the classroom. *Comput Human Behav* 2016;56:21–8.
- [2] Penney D, Jones A, Newhouse P, Cambell A. Developing a digital assessment in senior secondary physical education. *Phys Educ Sport Pedagog* 2012;17:383–410.
- [3] Wongwatkit C, Prommool P, Chookaew S, Mee-inta A. A Mobile Web Application for Learning Outcome Evaluation: Analysis and Design of Teacher and Student Interfaces. 2018 Glob. Wirel. Summit, IEEE; 2018, p. 151–5.
- [4] Krause JM, O'Neil K, Jones E. Technology in Physical Education Teacher Education: A Call to Action. *Quest* 2019:1–19.
- [5] Keengwe J, Bhargava M. Mobile learning and integration of mobile technologies in education. *Educ Inf Technol* 2014;19:737–46.
- [6] Healey D. Technology Enhanced Learning Environments. *TESOL Encycl English Lang Teach* 2018:1–6.
- [7] Hebden L, Cook A, Van Der Ploeg HP, Allman-Farinelli M. Development of smartphone applications for nutrition and physical activity behavior change. *J Med Internet Res* 2012;1:e9.
- [8] Goad T, Towner B, Jones E, Bulger S. Instructional Tools for Online Physical Education: Using Mobile Technologies to Enhance Learning. *J Phys Educ Recreat Danc* 2019;90:40–7.
- [9] Richey RC, Klein JD. Design and Development Research. *Handb. Res. Educ. Commun. Technol.*, New York, NY: Springer New York; 2014, p. 141–50.
- [10] O'Connor S, Andrews T. Smartphones and mobile applications (apps) in clinical nursing education: A student perspective. *Nurse Educ Today* 2018;69:172–8.

Effectiveness of Digital Learning in Primary Schools at COVID-19

Jonni Siahaan¹, Rif'iy Qomarrullah², I Putu Eka Wijaya Putra³
 {jonni.siahaan@gmail.com¹, qommarrifqi77@gmail.com², ekawijayap@gmail.com³}

Cenderawasih University, Jayapura Papua, Indonesia¹²³

Abstract. This type of research is quantitative, the subjects of this study involved 31 5th grade elementary school students. The targets of the research target are health science education teaching materials. This study uses an instrument rubric assessment of student activity and learning response questionnaire by involving parents in its implementation. After conducting this research for one month, and checking through video recordings of student activities with parents collected during the activity. The results of data analysis in this study show that from the formative class evaluation above the average and from the learning data process and product results graphically each learning has increased. This shows if digital learning is accepted and understood by students. Therefore, digital media was very helpful during the Covid-19 pandemic outbreak disaster. However, in the future it is necessary to collaborate with the world of education and assist parental involvement in digital-based learning.

Keywords: digital learning, students, Covid-19

1 Introduction

Developing civilization on the basis of pluralism is a spirit in the culture of the archipelago (nusantara). Therefore, the various character of education in Indonesia includes three main elements, namely: first, “ing ngarsa sung tuladha” (before becoming a role model); second, “ing madya mangun karsa” (in the middle of the example); and third, “tut wuri handayani” (giving freedom by monitoring). This educational ideology as outlined by Ki Hadjar Dewantara as a hero of national education[1] ¹.

Elementary school (SD) as part of the stages of basic education is the entrance to how the younger generation of civilization is formed. This period is then known as the most important period of knowledge transfer in the learning process. Children are trained to know the rows of letters and numbers, scientific didactic methodology recognizing reading and counting applies throughout the world. Education in turn cannot be separated from the curriculum. Indonesia itself with a diversity of cultures, ethnicities, religions, and races is unique in the application of teaching materials. The curriculum is a set of material list packages arranged in each subject[2]². The objectives of

the curriculum are 4 competencies: a. Spiritual; b. Social behavior; c. Knowledge; and D. Skills. The curriculum currently in effect in Indonesia is K-13 (curriculum in 2013). Furthermore, in the implementation of K-13 there are competency standards which are indicators of achievements in the teaching and learning process which are divided into two: a Basic competence (KD)[3]³: contains indicators of performance in general that are applied in the perspective of all subjects, and b. Core competence (KI): contains indicators of focus on achievement in each subject.

A phenomenon that occurs is that education in the era of disruption such as now makes teachers have to adapt to all technological advances, especially after the emergence of the Covid-19 pandemic epidemic throughout the world. Covid-19 or coronavirus disease 2019 is a disease caused by a new type of coronavirus, Sars-CoV-2, which was first reported in Wuhan China on December 31, 2019[4]⁴. Common symptoms caused by Covid-19 by people infected with this virus that will experience symptoms such as cough, flu, sore throat, shortness of breath, lethargy and fatigue even in some cases patients will experience pneumonia or lung problems. The incubation period of Covid-19 between the period of contracting the virus and the appearance of symptoms of the disease, is generally estimated to range from 1 to 14 days or can be around 15 days.

The impact arising from this outbreak in the industrial era 4.0 is the existence of a new order of life which then relies on digitizing the system. The field of education as also affected then transformed to conduct disruption of teaching methods by conducting online or digital-based educational learning[5]⁵. This event marked a change in the behavior of educators and students in which digital learning which initially only became the main distraction in teaching methods in the classroom today amid the epidemic of the Covid-19 virus pandemic in 2020 became the main focus. Students scattered in 175,090 primary schools in Indonesia must be closed for a time limit that has not been determined until when the normal details[6]⁶. The problem that arises is that people are not used to it, especially teachers, students and parents facing the current emergency medical situation. Pandemic Covid-19 has made 24,757,561 students, and 1,467,461 elementary school teachers in Indonesia to carry out distance learning (PJJ) from their respective homes.

Based on research data from various sources in May 2020, specifically for the Papua Province region, the number affected by Covid-19 was 438,038 students and 16,023 teachers spread in 2,646 elementary schools. Geographically, Papua Province consists of 29 Regencies / Cities, with an area of 316,553.07 Km² (square kilometers), or equivalent to 3 times the area of Java which covers 128,297 Km². Papua's relatively unbalanced condition when compared to other provinces in Indonesia in terms of infrastructure and technological outreach is also a problem. But in the midst of existing limitations, teachers continue to strive to carry out distance learning. Based on this situation, the researcher was moved to do real work by making a break-

through in digital learning in collaboration with grade 5 teachers of SDN Inpres Perumnas 1 Heram, Jayapura City. The teaching material provided is a combination of digital-based learning and material insertion which also touches on a healthy lifestyle and educates students and parents in order to overcome Covid-19 transmission.

As explained earlier, the implementation of KD and IC in elementary schools is using an integrated thematic concept, where in the implementation of learning in the classroom the teacher uses stories in one or two more interrelated themes between subjects. The integrated thematic, taught at grade level 1 to grade 6. Specifically, this study focuses on grade 5 grades in primary schools in which there is the theme of clean air for health. Researchers and teachers then formulate the media used and focus on the right material to be taught. Zoom and whatsapp (WA) application media are then agreed upon by researchers and teachers to be used in the implementation of digital-based learning. Zoom is an application that is easy, inexpensive, does not require a device that is too difficult, and can load various kinds of people from all over the city of Jayapura. In addition, WA media was chosen because it can unite a variety of cellular telephone numbers in a group[7]⁷, coordination in the WA group becomes important to ensure the role of parents in mentoring students who participate in this learning activity.

Socially and culturally, another impact arising as a result of the emergence of Covid-19 for humans in the future is a change in new behavior or new life. Humans, viruses, and the digital world will co-exist well. Social isolation for a long period of time is not an effective solution. All sectors including the education sector are very beneficial in the presence of this kind of research. So in addition to the efforts that researchers have made, it is hoped that there will be other researches that are able to provide active solutions in an effort to bring an education sector that adapts to the disruption of the developing world.

2 Method

This research uses quantitative descriptive positivistic method, which reveals facts based on data according to the incident as it happened. Disclosure of facts is collected using numerical data (numbers) in answering problems for a phenomenon that appears at this time[8]⁸. This study aims to find the magnitude of the relationship between the independent variables with the dependent variable in one research subject empirically. Based on the extent and scope of the study, a pre-experimental design with a one-shot case study pattern was chosen in the data collection process. The treatment in this study was given to grade 5 students at SDN (public elementary school) Inpres Perumnas 1 Heram, Jayapura City, Papua Province of Indonesia, who carried out learning from their homes during the Covid-19 pandemic. The main subject of this research is the thematic learning “clean air for health”. There were 31 students involved as subjects in the study, consisting of: 17 boys and 14 girls. The implementation of this research is from March to April 2020. This study provides

interaction between students, teachers, researchers, and parents, where the zoom application is used when face-to-face giving teaching material, and WA media contains instructions, and information and communication interactions between parents and teachers. Thematic integrated in this study is “clean air for health”, and is divided into 3 segments, including: (1) Sub-theme one: the way the body processes clean air; (2) Sub-theme two: the importance of clean air for breathing; and (3) Sub-theme three: maintaining the health of human respiratory organs. This study uses two instruments, namely: (1) Formative Evaluations in Online Classes (FEOC); and (2) Rubric of student performance learning outcomes assessment.

This study uses descriptive statistical analysis techniques. This is done to describe the effectiveness of learning based on the criteria indicators that have been prepared. Descriptive statistics explain facts that occur based on data, then the findings that occur in research are translated into languages that provide justification. The following is the range of scores and categories in formative class evaluation: (1) ≥ 2.77 (excellent); (2) 2.55-2.76 (good); (3) 2.34-2.57 (moderate); (4) 2.15-2.33 (poor); (5) ≤ 2.14 (very poor) [30]. Next is the conversion score of the process components and student learning products: (1) 91-100 (excellent); (2) 76-90 (good); (3) 61-75 (moderate); (4) 51-60 (poor); (5) < 50 (very poor)[9]⁹. Then, to determine the success of the study used interpretations of learning analysis using a cluster of qualitative sentences in the form of: (1) 81% -100% (excellent); (2) 75%-85% (good); (3) 65% -74% (moderate); (4) 55% -64% (poor); (5) $< 54\%$ (very poor)[10]¹⁰.

3 Results and Discussion

The results represent exposure to the data that researchers have found and obtained from subjects, the description can be presented in the form of four data points as follows:

Based on the formative class evaluation data filling which aims to obtain student response data on the application of the learning model, this questionnaire contains several elements: results, volume, method, and cooperation. The first learning activities carried out on Monday 30 March 2020 obtained the following questionnaire data for students: (1) The results component consists of 3 questions with an average score range of 2.19; (2) Volition component consisting of 2 questions with an average range of scores is 2.58; (3) Component method which consists of 2 questions with a range of average scores is 2.34; and (4) Cooperation component consisting of 2 questions with an average range of scores is 2.47. Overall average range of scores in the first learning is 2.37, which means moderate;

The first learning activities that were held on Monday, April 6, 2020 obtained the following questionnaire data for students: (1) The results component consists of 3 questions with an average score range of 2.59; (2) Volition component consisting of 2 questions with an average range of scores is 2.58; (3) Component method which con-

sists of 2 questions with a range of average scores is 2.60; and (4) Cooperation component consisting of 2 questions with an average range of scores is 2.58. Overall the average range of scores in the first learning is 2.59, which means included in the good category.

The first learning activities that were carried out on Monday, April 13, 2020 obtained the following questionnaire data for students: (1) The results component consists of 3 questions with an average score range of 2.84; (2) Volition component consisting of 2 questions with an average score range of 2.79; (3) Component method which consists of 2 questions with a range of average scores is 2.35; and (4) Cooperation component consisting of 2 questions with an average range of scores is 2.60.

Table 1. Process and Product Learning Data

Activity	Product	Category
1	Beginning of learning (A)	64,19%
	Learning process (B)	66,78%
	End of learning (C)	71,94%
	\bar{X}	67,64%
2	Beginning of learning (A)	73,60%
	Learning process (B)	77,04%
	End of learning (C)	79,08%
	\bar{X}	76,57%
3	Beginning of learning (A)	79,83%
	Learning process (B)	80,27%
	End of learning (C)	82,51%
	\bar{X}	80,87%

Source: Research Data for 2020

Based on the data in Table 1., it can be explained as follows: (1) The first learning that was carried out on Monday 30 March 2020 obtained data that: component A with an average percentage of learning was 64.19%, component B with an average percentage of learning was 66.78%, and component C with an average the average percentage of learning is 71.94%. As a percentage of the final average in the first learning is 67.64%, which later in this study belongs to the moderate category; (2) The second learning that was carried out on Monday, April 6, 2020, obtained data that: component A with an average percentage of learning was 73.60%, component B with an average percentage of learning was 77.04%, and component C with an average the average percentage of learning is 79.08%. As a percentage of the final average in the first learning is 76.57%, which then in this study is included in the good category; and (3) The third learning that was carried out on Monday, April 13, 2020, obtained data that: component A with an average percentage of learning was 79.83%, component B with an average percentage of learning was 80.27%, and component C with an average the average percentage of learning is 82.51%. As a percentage of the final average in the first learning is 80.87%, which then in this study is included in the good category.

After the presentation of research data, further discussion of the discussion can be described as below:

First, relating to formative class evaluation data, when discussing learning carried out by teachers inside and outside the classroom that will have more meaningfulness if it involves students actively. The teacher acts as a facilitator and puts himself as a pleasant friend, therefore how students feel in carrying out the learning process also needs to be expressed. Formative class evaluation is a questionnaire given to students that aims to find out what level of student acceptance in learning. As explained in the results of the research that has been carried out obtained data from students' questionnaire inputted by <https://forms.office.com/> as follows: (1) The average data range of scores in the first learning is 2.37 which means included in the moderate category; (2) The average data range of scores in the first learning is 2.59 which means it is included in the good category; and (3) The average data range of scores in the first learning is 2.67 which means it is included in the good category. The results of this study have links with research that has been conducted by several researchers, namely: (1) Self-motivation, quality and service of teacher learning, and the effects of peers have a positive and significant impact on student learning outcomes[11]¹¹; (2) Students who get attention and good facilities have high learning motivation and have an impact on learning outcomes in class; and (3) There is a significant relationship between learning motivation with students' interest in learning in elementary school[12]¹². Learning is an interaction pattern of the acquisition process of habits, knowledge, and attitudes that change behavior related to character, physical, and psychological. Learning is influenced by two factors: internal and external. Then, with the support of these factors students have high achievement this means that the person has good knowledge of theories and concepts as well as an impact on behavior and attitude changes. Thus the consequences of an education is aimed at making a change from pessimistic attitude to optimism, people who when initially unable to do something become people who are able to even improve their achievements. This can be done by a teacher how they can provide motivation to be able to improve their learning achievement. Support in the learning process is carried out by presenting digital learning through the zoom application, researchers and teachers then provide animated learning shows about clean air for health, the way the body processes clean air and the impact of unclean air. It also displayed a video on how the benefits of clean air and how to maintain healthy lung health. Additional material was also provided, namely the danger of free air and the spread of the Covid-19 virus, how to wear masks and the health benefits of hand washing. Means and media that are interesting according to the contents of today's content become very interesting in the direction of the normal era of new life. Digital has evolved and become the foundation of learning interactions, then to achieve high learning outcomes required traits and behaviors such as: high aspirations, actively working on assignments, high trust, good interaction, readiness to learn and so on. The nature and characteristics required in the learning activities are only found in individuals who have high motivation, while

those who have low motivation do not exist so that it will hamper their learning activities.

Second, related to learning process and product data can be understood, namely teaching and learning activities are closely related to learning strategies, researchers use the zoom and WA applications that become more familiar in the middle of social distancing and physical distancing as it is today. The learning process is reflected in the results of the learning process and product which includes three components, namely: (1) Beginning of learning (A); (2) The process or core of learning (B); and (3) End of learning (C). Furthermore, these three components are averaged on the results to determine the level of success of the learning process. The learning outcomes data that have been carried out in this study are as follows: (1) The average learning data from the first component A + B + C is 67.64% which means moderate; (2) The second learning average data from components A + B + C is 76.57% which means good; (3) The average learning data of the three components of A + B + C is 80.87% which means good. Graphically the data of each lesson has increased in percentage, this shows the success of the application of the media used. This research has links with several previous studies, including: (1) Science learning has increased learning outcomes, teachers develop IT-based multimedia learning[13]¹³; (2) Development of interactive learning module (ILM) based on multimedia-mediated student-centered learning environment (MMSLE) can increase motivation to learn in class; and (3) The ways of innovative learning methods with intense teacher and student interactions, provide the closeness of learning[14]¹⁴. Literally, the teaching and learning process is the interaction of reciprocal communication between the instructor as the source of the message and the recipient of information, namely students through media channels. Utilization of learning resources in the form of attractive digital learning media, can make the process of communication through distance learning take place more effectively and efficiently. The success of delivering a good message from the teacher, can stimulate the thoughts, feelings, interests, and attention of students, then in turn teaching and learning interactions can take place. Digital media can play a role as a tool that has the role of: (1) Tools for introducing information, in this case clean air material for health and the Covid-19 outbreak; (2) Providing new and enjoyable experiences for teachers and students; (3) Tools for increasing knowledge and skills in learning; (4) Growing students' interest and motivation to learn because learning is more interesting; and (5) Being able to help shape students' mental models. Therefore, the role and task of the teacher can then be shifted from the main learning resource to a learning resource manager.

4 Conclusion

Based on the background of the problem, the results of the study and discussion in this study, the following conclusions can be drawn as follows: (1) Formative class

evaluation data show that students' interest and motivation towards digital learning carried out is above the average of moderate, this gives an understanding if digital-based learning is accepted and understood by students; and (2) The results of learning process data and product graphically data from each learning experience increases in percentage, this shows the success of the application of digital-based media used.

5 Suggestion

Recommendations that can be given from the results of this research study are: (1) Teachers in the midst of this pandemic have more time to prepare teaching materials that were originally using manual guidance that can be transferred with digital media; (2) Parents are able to give more time to be with students at home, and parenting education is becoming increasingly necessary after this pandemic outbreak; (3) This research has only been carried out in a limited scope, research is needed with a wider scope and developments in digital media that are easily applied by teachers and students.

References

- [1] Mudana IGAMG. Membangun karakter dalam perspektif filsafat pendidikan Ki Hadjar Dewantara. *J Filsafat Indones* 2019;2:75.
- [2] Prastowo A. Transformasi kurikulum pendidikan dasar dan menengah di Indonesia. *JIP J Ilm PGMI* 1970;4:111–25.
- [3] Ulfa Hidayah , Ida Bagus Putrayasa INM. Konsistensi kompetensi inti (KI), kompetensi dasar (KD), dan indikator pada evaluasi guru dalam pembelajaran eksposisi berdasarkan kurikulum 2013 siswa kelas X MAN Patas. *Pendidik Bhs Dan Sastra Indones Univ Pendidik Ganesha Jur Pendidik Bhs Dan Sastra Indones* 2016;5.
- [4] Yuliana. Corona virus diseases (Covid -19); sebuah tinjauan literatur. *Wellness Heal. Mag.*, vol. 2, Sello Editorial Javeriano; 2020, p. 187–92.
- [5] Purwanto A, Pramono R, Asbari M, Santoso PB, Wijayanti LM, Choi CH, et al. Studi eksploratif dampak pandemi COVID-19 terhadap proses pembelajaran online di sekolah dasar. *EduPsyCouns J Educ Psychol Couns* 2020;2:1–12.
- [6] Setiawan AR. Lembar kegiatan literasi saintifik untuk pembelajaran jarak Jauh topik penyakit Coronavirus 2019 (COVID-19). *J Edukatif* 2020;2:28–37.
- [7] Kumari S, Mittal R. WhatsApp: A worth medium of communication for transfer of technology to the masses. *Curr J Appl Sci Technol* 2017;23:1–9.
- [8] Safitri I, Pasaribu R, Simamora SS, Lubis K. The effectiveness of android application as a student aid tool in understanding physics project assignments. *J Pendidik IPA Indones* 2019;8:512–20.
- [9] Wildan W. Pelaksanaan penilaian autentik aspek pengetahuan, sikap dan keterampilan di sekolah atau madrasah. *J Tatsqif* 2017;15:131–53.
- [10] Nurpratiwi, R. S., Sriwanto, S., Sarjanti E. Peningkatan aktivitas dan prestasi belajar siswa melalui metode picture and picture dengan media audio visual pada mata pelajaran geografi di kelas XI IPS 2 SMA Negeri 1 Bantarkawung. *Geo Edukasi* 2015;4:1–9.
- [11] Lee I. The effect of learning motivation , total quality teaching and peer-assisted learning on study achievement: empirical analysis from vocational universities or colleges ' students in Taiwan. *Adult Learn* 2010;6:56–74.

- [12] Fauziah A, Rosnaningsih A, Azhar S. Hubungan antara motivasi belajar dengan minat belajar siswa kelas IV SDN Poris Gaga 05 Kota Tangerang. *J JPSD (Jurnal Pendidik Sekol Dasar)* 2017;4:47.
- [13] Akhlis, I. Dewi N. Pengembangan media pembelajaran IPA Terpadu Berkarakter Peduli Lingkungan Tema “Konservasi” Berpendekatan Science-Edutainment. *J Pendidik IPA Indones* 2013;2:203–8.
- [14] Almarabeh H, Amer EF, Sulieman A. The effectiveness of multimedia learning tools in education. *Int J Adv Res Comput Sci Softw Eng* 2015;5:761–4.

Effect of Temperature on Spermatozoa Morphology

Khori Halimah¹, Ari Yuniastuti², Sri Ratna Rahayu³
 {khorihalimah5@gmail.com¹, ari_yuniastuti@yahoo.co.id², sratnarahayu@mail.unnes.ac.id³}

Universitas Negeri Semarang, Semarang, Indonesia¹²³

Abstract. Infertility is an important health and social problem. There are 15% of couples are infertile and 40% are infertile due to male infertility in the world. Temperature exposure is one of the determine factor in the normal percentage of spermatozoa morphology. This study generally aims to determine the effect of temperature exposure on spermatozoa morphology. Laboratory experimental research method was conducted by a post-test only control group design, carried out on 12 mice (*Mus musculus*). Mice were divided into 2 groups randomly, the control and treatment group with less and more than 35 °C (KK) temperature exposure consecutively in the UD Grinding Mill Berkah Tani (KP) rice mill for 35 days. The samples were terminated, spermatozoa were taken and preparations were made using *gymsa painting* on the 36th day. The results showed there was a significant difference of spermatozoa morphology between control and treatment group ($p < 0.05$).

Keywords: temperature, morphology of spermatozoa, rice mill

1 Introduction

Infertility can be interpreted as the inability to reach conception in a one-year period for a partner, even though sexual intercourse without a condom is regular and adequate. A man is said to be infertile if he cannot impregnate his partner after one year of unprotected sexual intercourse. [1]. This is an important medical and social problem in the world, 15% of infertile couples and 40% are infertile due to male infertility [2]. Infertility has become an unpleasant problem, which is not only limited to these countries, but is also an incident worldwide. In the United Kingdom and the United States, it is estimated at 6% and 10%, respectively. In Nigeria and parts of sub-Saharan Africa including the Republic of Sudan and Cameroon, the infertility rate can exceed 30% [3].

There are several main causes and risk factors for male infertility namely, environmental factors, lifestyle factors. Men with infertility will experience self-esteem gangguan and social inability, which in turn will cause a decrease in responsibility towards his wife and family [4]. Male infertility can be associated with sexual disorders in partners. Attention to psychological needs and rehabilitation in infertile couples can help them improve mental health and quality of life [5].

Today there is an increase in industrial activity in various countries [4]. Increased industrial activity resulted in an increase in temperature exposure [6]. Stress affects the work of the hypothalamus associated with GnRH secretion. GnRH levels affect the production of FSH and LH in the pituitary. Where LH will stimulate Leydig cells to produce testosterone and FSH stimulate Sertoli cells to maintain the process of spermatogenesis in the testes. The mechanism of severe stress that affects the hormonal system is what influences fertility. Temperature of testis to produce healthy spermatozoa must be cold from the body's normal temperature, which is 35°C. Increased temperature can also reduce the quality of the morphology of spermatozoa, resulting in decreased fertility that occurs in men. The results obtained show that 25 ° C has a high progressive movement of sperm and sperm viability compared to 4 ° C and 37 ° C. Sperm stored at 25 ° C shows normal morphological structure while there are morphological changes in the temperature of 4 ° C and 37 ° C [6].

Based on the description above, research has been carried out on experimental animals in the laboratory by using tools as a source of temperature. Previous research has never been carried out directly in industrial workplaces, so it is necessary to study the effect of temperature exposure on workers exposed to temperature in their work. In the research to be carried out, the object of research is in the form of mice that are exposed to the temperature of a rice mill because it is difficult to get respondents who are willing to do spermatozoa examination.

2 Method

2.1 The method of research

The type of research to be conducted is an experimental study with the research design to be used is the Post Test Only Randomized Control Group Design.

2.2 The population in this study

The population in this study is mice (*Mus musculus*) with male sex which are kept in the biology laboratory of Darno Tikus Gunung Pati. The sample used in this study is 18 mice will be divided into two groups randomly. The number of samples used in the study was calculated using the WHO stipulation, namely the minimum number of experimental animals per group was 5, and added 1 tail to avoid the possibility of lost of follow, so that the total number of mice per group was 6 .

2.3 The place of research

The place of research was conducted at the UD Rice Mill. Berkah Tani, Pekalongan Regency. The activities were carried out in October 2019 until November 2019.

Sampling was carried out on the 36th day, mice in each group will be killed by the cervical dislokatio method. Then the sperm is taken by cutting the cauda epididymis until the ampulla vas deferens about 1.5 - 2 cm and then sorted by scapel and placed in a petri dish that has been filled with 0, 25 cc of physiological NaCl 0.86%

solution that is 0.9 grams NaCl powder mixed with 100 ml of aquabidest. In the process of taking it must be as fast as possible and immediately carried out morphological examination.

The validity and reliability test of the instrument in the form of the instrument will be calibrated at the Sultan Agung Islamic University Integrated Laboratory. All data obtained are then analyzed and seen whether or not normal data using the normality test using Shapiro Wilk and homogeneity testing with the Levene test. Followed by an unpaired T test with a significance value ($p < 0.05$). Statistical tests were performed with the SPSS program on a computer.

3 Results and Materials

3.1 Results

Observation of morphology of spermatozoa using a microscope with 1000x magnification using giemsa staining, which was assessed as spermatozoa with normal spermatozoa characteristics that have the shape of the head like a fishing hook and straight long tail, while abnormal sperm have irregular head shape, can be shaped like a banana, or irregular (amorphous), or too bent, and the tail is not straight or even has no tail, or there is only a tail without a head.

Data were tested for normality to find out the distribution of data evenly by using the Shapiro-Wilk test. Both groups showed that the initial data distribution was not normal but the data was transformed to obtain an average morphological percentage of spermatozoa in all groups with normal distribution with a P value > 0.05 . Then homogeneity test with Levene test was performed. Based on homogeneity test results obtained P value < 0.05 . This shows that the morphological data of spermatozoa in all groups was normal and homogeneous.

Because of the normal distribution of data and homogeneous data variations, an unpaired T test was obtained with a price of $p < 0.05$. The results showed that between the control group and the treatment group there were significant differences in the morphology of spermatozoa with a value of $p = 0,000$ ($p < 0.05$). This shows the temperature exposure for 35 days there is a difference. so as to prove there are differences in the morphology of spermatozoa with a lower morphological average, these results are in accordance with research conducted by [7].

Table 1. Morfology of Spermatozoa

Sample	Normal (%)	Abnormal (%)
1.1	92	8
1.2	94 ...	6
1.3	96	4
1.4	98	2
1.5	98	2
1.6	95	5
1.7	90	8
2.1	52	48
2.2	58	42
2.3	56	44
2.4	64	36
2.5	64	36
2.6	60	40
2.7	58	42

3.2 Materials

Workers who are constantly exposed to noise and high temperatures will experience a state of stress that continues to increase [8]. Stress due to noise and temperature will stimulate the brain's Paraventricular Nucleus (PVN) to secrete Corticotrophin Releasing Hormone (CRH) and Arginine Vasopressin (AVP), where the hormone will increase the secretion of Adeno Corticotropin Hormone (ACTH) which will cause a decrease in hormone levels which is produced by the hypothalamus, Gonadotropin Releasing Hormone (GnRH). GnRH levels affect the production of FSH and LH in the pituitary. Where LH will stimulate Leydig cells to produce testosterone and FSH stimulate Sertoli cells to maintain the process of spermatogenesis in the testes. LH serves to stimulate Leydig cells to produce testosterone and maintain the morphology of testosterone to remain high in the testes. Testosterone and FSH will work on the Sertoli cells will produce a variety of proteins, differentiation and cell metabolism that will maintain normal spermatogenesis [6].

The motility check is to find out whether there are abnormalities in the spermatozoa tail structure, if there are many immotile spermatozoa alive then there are abnormalities in the spermatozoa tail structure, especially in the flagellum structure. Meanwhile, testosterone and FSH will work on Sertoli cells will produce various proteins, differentiation and cell metabolism that will maintain normal spermatogenesis [6]. Where fertility in a man can be seen from the quality and quantity of normal spermatozoa which include sperm count, motility, morphology and ejaculate volume [9]. Stress due to noise will stimulate the brain's Paraventricular Nucleus (PVN) to secrete Corticotrophin Releasing Hormone (CRH) and Arginine Vasopressin (AVP), where the hormone will increase the secretion of Adeno Corticotropin Hormone (ACTH) which will result in decreased hormone levels produced by the hypothala-

mus, namely Gonadotropin Releasing Hormone (GnRH). GnRH levels affect the production of FSH and LH in the pituitary. Where LH will stimulate Leydig cells to produce testosterone and FSH stimulate Sertoli cells to maintain the process of spermatogenesis in the testes [10].

LH functions to stimulate Leydig cells to produce testosterone and maintain the morphology of testosterone to remain high in the seminiferous tubules in the testis. Testosterone and FSH will work on the Sertoli cells will produce various proteins, differentiation and cell metabolism that will maintain normal spermatogenesis.

Hormonal system in the form of testosterone secretion, FSH and LH is what influences the formation of normal spermatozoa morphology. So that if there is a disruption in the production of the hormone spermatogenesis, the morphology of spermatozoa will be affected.

4 Conclusions and Suggestions

From the description of the results of the research that has been done, it can be concluded as follows: Obtained the effect of temperature on rice milling on spermatozoa morphology. There is a difference between the control group and the treatment group.

Acknowledgments Thank you to Dr. Rr.Sri Ratna Rahayu, M.Kes., Ph.D and Dr.Ari Yuniastuti, Spt., M.Kes, as supervisors who have provided direction and guidance for this study.

References

- [1] Mahat, Roshan, K. etc. . "Biochemistry & Analytical Biochemistry Risk Factors and Causes of Male Infertility." *Biochemistry & Analytical Biochemistry*, 2016,5(2): 1002–71.
- [2] Mescher Mahat, Roshan, K. etc. "Biochemistry & Analytical Biochemistry Risk Factors and Causes of Male Infertility." *Biochemistry & Analytical Biochemistry*, 2016, 5(2): 1002–71.
- [3] Sharma, Asha., "IMedPub Journals Male Infertility; Evidences , Risk Factors , Causes , Diagnosis and Management in Causes and Risk Factors of Infertility." *Annals Of Clinical and Laboratory Reserch*, 2017,5(3): 1–10.
- [4] Joja, O D, D Dinu, & D Paun. "Psychological Aspects of Male Infertility. An Overview 1." *Social and Behavioral Sciences* 2015, 187: 359–63.
- [5] Ghavi, Fatemeh, Leili M., Saeed A., & Masomeh G. J.. "Male Infertility and Its Impact on Women's Sexual Behaviors: Need Attention to Psychological Problem as a Psychological Rehabilitation." *Iranian Rehabilitation Journal*. 2017,15(2): 87–94.
- [6] Adewoyin, Malik etc., "Male Infertility : The Effect of Natural Antioxidants and Phyto-compounds on Se Mayowa al Oxidative Stress." *Disease*, 2017,5(9): 1–26.
- [7] Harrahap,I., Erris. "Pengaruh Kebisingan Terhadap Kuantitas Dan Kualitas Spermatozoa Tikus Putih (*Rattus Norvegicus*) Jantan Dewasa." *Media Litbangkes*, 2014, 24 (3): 123–28.
- [8] Soom, Ann V. "Theriogenology Heat Stress Responses in Spermatozoa : Mechanisms and Consequences for Cattle Fertility." *Theriogenology Elsevier Journal*, 2018, 113: 102–12.

- [9] Sukmaningsih, dkk. "Gangguan Spermatogenesis Setelah Pemberian Monosodium Glutamat Pada Mencit (*Mus Musculus L.*) The Disturbance On Spermatogenesis After Administration Of Monosodium Glutamate On Mice (*Mus Musculus L.*)." *Jurnal Biologi*, 2009, (2): 49–52.
- [10] Jalali, Maryam, & Khodabakhsh K. (2012). "Effect of Noise Stress on Count , Progressive and Non- Progressive Sperm Motility , Body and Genital Organ Weights of Adult Male Rats." *Joundishapour University of Medical Science Journal*, 2012 .5(1): 1–4

Lecturer in the COVID-19 Pandemic Period at 30 Universities in Indonesia

Khurotul Aini¹, Aisya Kemala²
{khurotulainiunismabekasi@gmail.com¹, aisyakemala@gmail.com²}

Bekasi Islamic Universities, Bekasi, Indonesia¹²

Abstract. The Covid-19 virus changes in the implementation of learning at the university. This study aims to determine the implementation of lectures conducted online in the department of physical education and health. The study uses a survey method. The results showed 100% they are lecturers in physical education and health faculty, 100% universities were affected by co-19. 100% haven't. 70.1% lecture material was accepted by students and 29.9% expressed doubt. 89.6% took the exam online, 10.4% didn't. 58.4% had difficulty doing online assessments and 41.6% had no. 76.6% used the Zoom, 51.9% Google Classroom, 41.6% Google Meet, 28.6 Edmodo, 1.3% Teacher's room, 2.6% Cisco Webex, 2.6% Ms. Office 365, 1.3% Google for Education, 14.52% Whatsapp, 1.3% Youtube and 2.6% E-learning University. 73.7% stated online and 26.3% said no. 23.4% have barriers to lecturing online, 63.6% sometimes and 13% don't. So online lectures can be held in the current Covid-19 conditions.

Keywords: Covid-19, physical education, online learning

1 Introduction

This Word document can be used as a template for papers to be published in EAI Core Proceedings. Follow the text for further instructions on text formatting, tables, figures, citations and references. The occurrence of corona virus disease (Covid-19) resulted in many losses in all fields throughout the world. Of course this requires all parties to cooperate with each other and support activities in various fields to keep going with the adaptation to health protocols recommended by their respective governments around the world. Likewise with the implementation of lectures at the university level. In several universities in the world have carried out health protocols according to the recommendations of the governments of each country. As Crawford argues that there are universities that adjust government recommendations such as abiding by quarantine for 14 days, keeping minimum distance, turning face-to-face learning into online learning as a result of the Covid-19 outbreak[1]. Line state that coronavirus (COVID-19) the deadly virus that causes respiratory illness and pneumonia[2]. Because the spread of this virus through humans occurs due to close contact with infected people, coughing, sneezing, respiratory droplets and can penetrate the human body (lungs) through inhalation through the nose or mouth[3]. There is currently no evidence to support transmission of COVID-19 associated with food. The COVID-19 virus may survive on surfaces for several hours, but simple disinfectants can kill it[4].

Officially the President of Indonesia, Joko Widodo, through a video uploaded by the Secretariat Press, Media and Information Bureau through the account of the Presidential Secretariat on May 15, 2020, on the easing of large-scale social restrictions [5] as one of the strategies to prevent the spread that has been implemented before large-scale social restrictions in all regions in Indonesia. Of course this affects the activities of the population in Indonesia. Where many activities are carried out jointly such as activities in schools, campuses, offices, buying and selling in markets and so on, but although this co-19 pandemic is global, the response is still local in nature which is influenced by regional governance and social, economic and culture[6].

The Indonesian state is scattered in the form of islands, demanding that the implementation of the CBDR be supported by the awareness of each individual for the common health interests. In the field of education experienced a pretty drastic change. lectures began to shift from meeting directly in class to being changed to online lectures, where lecturers could deliver lecture material from their respective homes. Favale states Covid-19 this forced people to change their habits and pushed them online services for learning, smart working etc on the internet[7]. Changes in habits that humans do as usual changes to new habits that are more likely to use online meetings, study, school, work and other socialization. Of course this needs to be prepared carefully. The readiness factor to carry out lectures online is the main factor to support this. There are 6 preparations that must be done if the lecture is done online. Bao explained the preparations included: (1) making emergency preparedness plans for unexpected problems; (2) dividing the teaching content into smaller units to help students focus; (3) emphasizing the use of "voice" in teaching; (4) working with teaching assistants and gain online supports from them; (5) strengthening students' active learning ability outside of class and (6) combining online learning and offline self-learning effectively[8]. One other important preparation is to assist in the use of online media that can be done by lecturers to students when conducting lectures online. Lloyd in Perrotta explained the state that mentoring is a key factor in effective online teaching, particularly with regard to fostering student engagement in the e-learning environment[1]. These preparations are important to be done carefully before carrying out lectures online.

Several universities have conducted lectures online, including universities that have major in physical education and health. Universities that have these majors certainly have many obstacles, this is because almost entirely for the Strata 1 level lectures are mostly done in practice in the field by doing physical activities. The following are the results of previous studies with the latest data found by researchers such as Jamaluddin stating that online learning can be used as an experience for prospective teachers[9]. Ginns conveys that there are important internal keys in implementing online learning such as perceptions of learning experiences when carrying out online learning [10]. The online lecture implementation of a lecturer needs to pay attention to important things such as student characteristics, methods / approaches of learning concepts to be conveyed, the stages of student learning and to know students' perceptions of teaching and the quantity and quality of assignments from educators[11]. So that researchers are interested in reviewing further about the implementation of lectures currently being conducted by physical education and health lecturers in Indonesia.

2 Methodology

In this study using descriptive qualitative research methods that are using survey techniques. This technique is carried out to collect data and information from research subjects conducted on 10-13 June 2020 with 77 respondents who work as physical and health education lecturers spread in 30 universities, both private and public in Indonesia. The technique of data collection is done by giving questionnaires to all respondents through the Google Drive Link Drive application. The following are parts of the instruments, among others: (1) respondent profile; (2) the impact of co-19 on agencies; (3) online lectures; (4) online lecture success in the academic process, (5) online lecture barriers; (6) types of applications used for online lectures.

3 Result

Based on the questionnaire collection via google form, the following results are obtained:

3.1 Profile of Respondent

The results of the collection questionnaire via google form the following results are obtained 100% a lecturer in physical education

3.2 The impact of Covid-19 on institutions

The impact of Covid-19 on the workplace agency received a response of 100% stating that covid-19 had an impact on the workplace agency. Where the campuses have carried out lecture activities and other academic activities carried out from their respective homes.

3.3 Online lectures

In this section the researcher developed the instrument based on the online lectures conducted at 30 universities in the department of physical education and health. The results of the respondents as much as 100% stated that the lecture was conducted online. This online lecture is a recommendation from the faculty to lecturers in physical and health education referring to the recommendation formally submitted by the government of the Republic of Indonesia. Implementation of lectures online has been carried out in accordance with regular lecture schedules.

3.4 Distribution of lecture implementation in accordance with the faculty

The results obtained as much as 100% of the responses stated that they have carried out the lectures in accordance with the faculty's recommendations. In accordance with the advice of the faculty here is about the weight of the task, meetings, schedules in accordance with the rules set by the faculty.

3.5 Distribution of lecture material acceptance to students

For the implementation of lectures conducted from each home, of course less effective in the range of acceptance of the material, especially for students. In **Figure 1** it is known that as many as 70.1% of respondents stated that lecture material was acceptable to students while 29.9% of responses expressed doubt over the mastery of the material submitted online. This is certainly reasonable if previously students have been accustomed to receiving material directly through face to face in class where in general students will be more concentrated when there are lecturers in the class. But now they are required to be able to adapt to the unusual conditions of conducting online lectures. Likewise, lecturers who are used to face-to-face in class and can explore lectures by listening directly to things that are preventing students from attending lectures, are now a little limited because of online learning. In addition, some courses in the physical education department are mostly done in practice in the field, lecturers are very limited to know the understanding of student material when doing physical activities in the home. This is also caused by the limited facilities and infrastructure that exist in each student's home. So from that lecturers must be able to adjust the types of media they will convey, especially in practicum subjects.

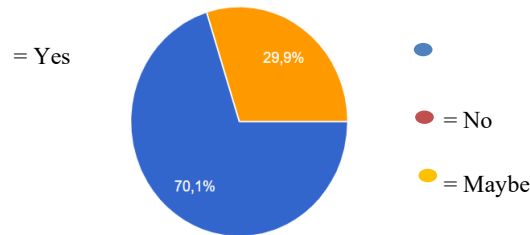

Fig. 1. Distribution of lecture material acceptance to students

3.6 Distribution of online examination implementation

For the As an evaluation material for learning including at the university level, of course there is a need for examinations. Both the midterm and final semester exams. In **Figure 2** it can be seen that as many as 89.6% of respondents said they had taken an online test and 10.4% of respondents said they had not yet taken an online test. Most lecturers are accustomed to conducting tests online both through learning applications and with e-learning that has been provided by their respective universities. But there are some universities that are not accustomed to doing online exams. So there are some lecturers from universities who have not used the online examination technique.

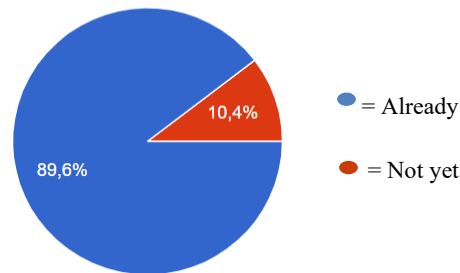

Fig. 2. Distribution of online examination implementation

3.7 Distribution of online test assessment

In **Figure 3** about the assessment of online examinations shows as many as 41.6% of respondents have conducted online learning assessment. As many as 58.4% have not yet conducted online learning assessments. In the distribution of data it is known that more lecturers have not yet conducted online assessments than those who have conducted online assessments. This is triggered by various reasons. The majority of lecturers still choose assessment techniques manually or offline. The habit of assessing students using manual techniques results in lecturers being reluctant to switch. The assessment conducted is not solely about the results of the final exam, but there are many considerations in making an assessment, for example the value of attendance, assignments and the value of exams that have been done, so that lecturers need more time to accumulate the overall value data owned.

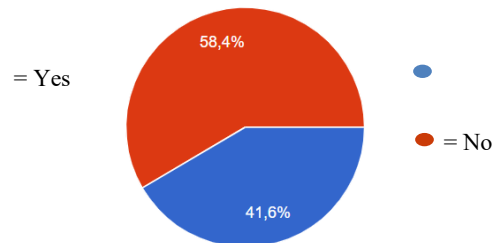

Fig. 3. Distribution of online test assessment

3.8 Distribution of ease of academic process through online

Based on **Figure 4** regarding the ease of academic activities such as lectures, final assignment guidance is known as many as 73.7% of respondents stated online simplified the academic process and 26.3% stated it did not facilitate the academic process. Most of them stated that they will go online for academic conduct on campus. At present many universities have carried out seminar proposals and results exams and even graduations were conducted online during the Covid-19 period. This is done because it does consider the transmission of Covid-19 through face-to-face or on mass or clustered activities. Each university has also provided academic facilities online such

as to find out the value of studies and study plans that can be accessed via smartphones that can be done anywhere and anytime.

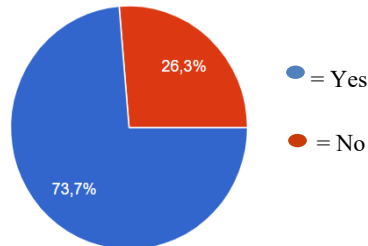

Fig. 4. Distribution of ease of academic process through online

3.9 Distribution of online lecture barriers

In **Figure 5** it is known that 23.4% of respondents have online lecture barriers, 63.6% sometimes and 13% say they do not have barriers if the learning process is done online. The obstacles presented by lecturers in the instrument section regarding the obstacles to the implementation of lectures online the majority stated that there are obstacles such as student areas scattered in the islands that are difficult to reach by internet signals resulting in smooth communication when lectures are slightly hampered. The limited quota owned by lecturers and students also results in obstacles during learning. The use of applications that require video and voice access requires a large quota if it is not supported by e-learning at each university. Another obstacle when using university e-learning is the limited use of the internet if smartphones and laptops or computers are not close to the campus area. So that the internet network cannot be freely accessed by students and lecturers who carry out lectures in their respective homes. So these obstacles require a review if the lecture is carried out online.

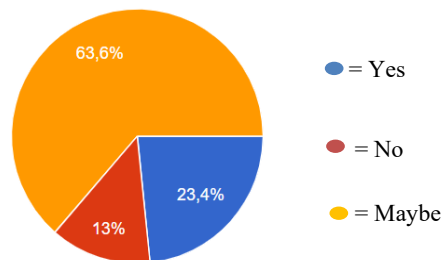

Fig. 5. Distribution of online lecture barriers

3.10 Applications distribution used for online lectures

In **Figure 6** instruments regarding the types of online learning applications that are used by lecturers when teaching, the results obtained are 76.6% of respondents using the Zoom application, 51.9% using Google Classroom, 41.6% using Google Meet, 28, 6 use Edmodo, 1.3% use Teacher's room, 2.6% use Cisco Webex, 2.6% use

Ms. Office 365, 1.3% use Google for Education, 14.52% use Whatsapp, 1.3% use Youtube and 2.6% use E-learning University respectively. There are 4 choices of the most important applications chosen by respondents namely Zoom, Google Classroom, Google Meet and Edmodo which means Zoom is the most important application used by respondents. The use of other applications also supports online learning. The choice of application type used depends on the needs of the lecture itself. The selection of the types of applications used is certainly used by lecturers to transfer knowledge that can be done with work from home. In addition, the selection of application types also depends on the level of ease of use of the application both access and application by lecturers and students. Some universities also have e-learning to facilitate the learning process. We know that it is important for university support to support lecturers and students to adapt to the new learning system. In order to keep the faith conveyed properly, even though they cannot meet in person.

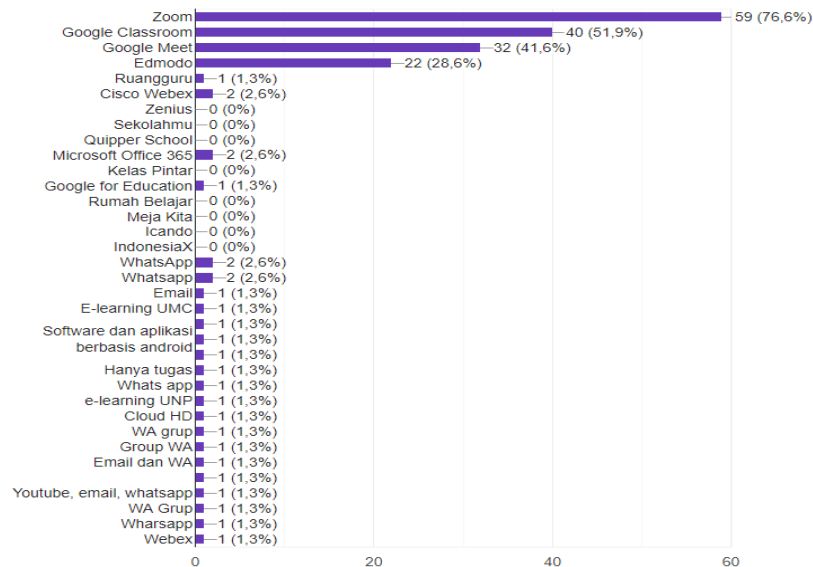

Fig. 6. Application distribution used for online lectures.

4 Discussion

The results of the study stated that online learning can be implemented well during the Covid-19 period. At this time the internet has a major role in supporting remote work, e-teaching, online collaboration, games, streaming video etc [7]. We live in a world that is globally connected, in terms of the movement of people, goods, and food, while even within close knit communities[12]. The virus has already had a direct impact on more than 10 million people in the city of Wuhan and has reached other parts of China as well, posing a health threat of unknown magnitude globally[13].

Covid-19 has now become a pandemic in various regions of the world. As a result of this many losses experienced both the countries affected directly and indirectly due to this virus. Major losses such as in economic, social, cultural and educational aspects.

Of course, these losses must be overcome immediately so that the economy continues to run well. One fundamental loss is a loss in education. The closure of schools and campuses can certainly impede and slow the achievement of targets already set by Governments and/or schools respectively[14]. In the COVID-19 era, the need for innovative solutions to optimize education faster [15]. We all know that education is the foundation of a country's development. The effect of Covid-19 in the field of education resulted in requiring every individual both educators and students to be able to adapt to new activities. Where activities begin to change from virtual to online learning, to carry out online learning at the university level also has many obstacles. These constraints are triggered by human resource factors in the application of the latest knowledge, the limited quota of each individual, as well as the network capacity of each region that is different, especially in Indonesia with widely spread island nations. These obstacles reduce the essence of the learning process or the transfer of knowledge itself if it experiences interference in terms of communication.

In addition to the online learning process, currently universities in Indonesia have also conducted online examinations and exam evaluations, although there are also exam assessments still done manually that is by considering other assessments in addition to exam scores such as attendance, assignments and student activeness during lectures. The online academic implementation process certainly requires lecturers to improve their literacy skills and sources of more updated and actual knowledge so that they can convey to students when learning takes place. The ability to create learning patterns that are tailored to current needs can be a learning material in the future. If currently conducting lectures online as a result of the covid-19 virus it is expected that in the future learning can be blended ie lectures face-to-face combined with lectures online. this is also mentioned in the results of research conducted by Ellis which states that online learning is one of the supporting lectures conducted face to face[16]. The selection of different learning methods will certainly reduce boredom for students and increase student interest in attending lecturer lectures, Jamaluddin also added that the online system can be an additional experience for prospective teachers in the future[9].

In the assessment process, of course, it also needs to be adjusted to the use of lectures online at the university level. The assessment of lectures is expected at this time to have been carefully prepared by the lecturer, so as to facilitate the performance of students and easily access the grades given by the lecturer in the course being taught. Daniel said that teaching should include varied assignments and work that puts COVID-19 in a global and historical context. When constructing curriculum and designing student assessment[17]. Covid-19 requires lecturers to change conventional teaching styles into modern learning while still achieving learning goals without reducing the content and essence of knowledge that will be transferred to students. In the physical education department for Strata 1, more practical hours are needed in the field, lecturers submit practical material online, then students also carry out and develop in their respective homes in accordance with instructions from the lecturer. Weaknesses when practicing at home are limited facilities and infrastructure that are not in accordance with the standards of the university, which results in students not maximizing when practicing independently. Online education is also very dependent on the server computer, smartphone so that there are possibilities that hosts in online learning application users find it difficult to operate or are limited in the number of participants who can follow certain media platforms so the lecturer must be deft to determine other

plans so that the implementation of lectures continues to be carried out. The lecture activities carried out online certainly have these obstacles usually followed by signal connection problems, quotas. In addition, lecturers are required to be varied when delivering lectures so that students do not experience boredom and passivity when lecturing online. To overcome this we can divide the lecture materials into small parts that can use a shorter duration than traditional learning.

If learning is conventionally supported by body language, facial expressions and voices from lecturers on online learning those things are certainly very limited. So it is important for lecturers to adjust the tempo of speech and convey important things related to the material presented because of the limitations of the signal in each different region. The implementation of online learning must also be supported by teaching resources that are responsive to the development of science and technology. But unfortunately many lecturers in Indonesia, especially for lecturers who are reluctant to switch to online learning, certainly require further assistance, the use of assistants in using the learning media platform is very necessary to fill in the blanks of online learning. Lecturers in online learning lack control in terms of student understanding of the material delivered online, sometimes students lack concentration when learning is done online, so to increase the level of student understanding lecturers prefer to use assignments so students are more active in developing knowledge. To improve student understanding based on the results of research conducted by Chick stated that by providing access to students to freely search for sources of literature from inter-university libraries through online can be used to improve science at this time[18]. To do online learning using a class discussion strategy is very limited because the distribution of communication in online learning platforms is usually very limited. So the depth of the contents of the material if delivered with a discussion is less efficient. Then the lecturer is expected to be able to develop a learning strategy that is suitable for use in the current Covid-19 period. In the research conducted by Ortiz stated that by forming a community of teachers or lecturers can be used as a means of communication and development of teaching methods in the classroom in online learning[19]. New strategies for carrying out lectures online are expected to be developed in an interesting way. It is important for faculty to carry out monitoring, mentoring and professional development of online teaching[20]. So that the implementation of online learning can be easily done by students and lecturers certainly requires the support of campus stockholders.

5 Conclusion

The main objective of this research is to find out the implementation and obstacles of lectures in the department of physical education and health in various universities in Indonesia when conducted online in the current Covid-19 mass. The results of this study indicate that with the Covid-19 virus condition lectures can be done online by lecturers to students through the available online learning applications. However online learning has several obstacles during implementation such as the number of Human Resources for operating online learning media platforms is still limited, the territory of Indonesia which is spread over several islands has resulted in unstable networks in certain regions, limited lecturer quota also resulted in learning online is not well done. Online lectures require lecturers to be creative and able to develop their

abilities, especially in the use of technology for lectures so they can be used as learning strategies in the future. Some applications that have been proven effective are used in online learning, including Zoom, Google Classroom, Schoology, and Edmodo[21]. So it is important to thoroughly prepare thoroughly before carrying out lectures online, although currently universities, especially in the department of physical education and health have carried out lectures online. This is nothing else so that the purpose of online lectures remains to be achieved and is carried out effectively and efficiently.

Acknowledgments Thank you to the members of the writing team who provided input in writing the article. and 45 Bekasi Islamic University which always supports the works of lecturers.

References

- [1] Crawford J, Butler-henderson K, Rudolph J, Malkawi B, Glowatz M, Magni PA, et al. COVID-19 : 20 countries ' higher education intra-period digital pedagogy responses. *J Appl Learn Teach* 2020;3.
- [2] Canady VA. Mental health groups providing support, education in wake of COVID-19. *Ment Heal Wkly* 2020;30:1–3.
- [3] Shereen MA, Khan S, Kazmi A, Bashir N, Siddique R. COVID-19 infection: Origin, transmission, and characteristics of human coronaviruses. *J Adv Res* 2020;24:91–8.
- [4] GUIDANCE FOR COVID-19 PREVENTION AND CONTROL 2020.
- [5] Sekretariat Kabinet Republik Indonesia _ Keterangan Pers Presiden Republik Indonesia mengenai Isu Penerapan Pelonggaran Pembatasan Sosial Berskala Besar (PSBB), 15 Mei 2020, di Istana Merdeka, Provinsi DKI Jakarta n.d.
- [6] Shaw R, Kim Y, Hua J. Governance, technology and citizen behavior in pandemic: Lessons from COVID-19 in East Asia. *Prog Disaster Sci* 2020;6:100090.
- [7] Favale T, Soro F, Trevisan M, Drago I, Mellia M. Campus traffic and e-Learning during COVID-19 pandemic. *Comput Networks* 2020;176:107290.
- [8] Bao W. COVID-19 and online teaching in higher education: A case study of Peking University. *Hum Behav Emerg Technol* 2020;2:113–5.
- [9] Proyeksi SD. Pembelajaran Daring Masa Pandemi Covid-19 Pada Calon Guru : 2020.
- [10] Ginns P, Ellis RA. the student experience of blended learning 2009;40:652–63.
- [11] Prosser M, Ramsden P, Trigwell K, Martin E. Dissonance in Experience of Teaching and its Relation to the Quality of Student Learning. *Stud High Educ* 2003;28:37–48.
- [12] Watkins J. Preventing a covid-19 pandemic. *BMJ* 2020;810:m810.
- [13] Chen P, Mao L, Nassis GP, Harmer P, Ainsworth BE, Li F. Coronavirus disease (COVID-19): The need to maintain regular physical activity while taking precautions. *J Sport Heal Sci* 2020;9:103–4.
- [14] Barid M, Wajdi N, Faruq U Al. Education Policy Overcome Coronavirus , A Study of Indonesians 2020;3:96–106.
- [15] Almarzooq ZI, Lopes M, Kochar A. Virtual Learning During the COVID-19 Pandemic. *J Am Coll Cardiol* 2020;75:2635–8.
- [16] Ellis RA, Ginns P, Piggott L. E - learning in higher education : some key aspects and their relationship to approaches to study 2009;4360.
- [17] Daniel SJ. Education and the COVID-19 pandemic. *Prospects* 2020.
- [18] Chick RC, Clifton GT, Peace KM, Propper BW, Hale DF, Alseidi AA, et al. ARTICLE IN PRESS Using Technology to Maintain the Education of Residents During the COVID-19 Pandemic. *J Surg Educ* 2020.

- [19] Ortiz PA. Teaching in the time of COVID-19. *Biochem Mol Biol Educ* 2020;48:201–201.
- [20] Perrotta K, Bohan CH. A Reflective Study of Online Faculty Teaching Experiences in Higher Education Katherine Perrotta, Mercer University, n.d.
- [21] Pratiwi EW. Dampak COVID-19 terhadap kegiatan pembelajaran online di sebuah perguruan tinggi kristen di Indonesia. *Univ Kristen Satya Wacana* 2020;34.

Indonesian Pencak Silat Athletes Management

Lesmana¹, Tatang Muhtar², Nurlan Kusmaedi³, Adli Hakama⁴
 {Ikalesmana1612@gmail.com¹, tatangmuhtar@upi.edu²,
 nurlankusmaedi11@gmail.com³}

Indonesia University of Education, Bandung, Indonesia¹²³⁴

Abstract. Researches concerning the implementation of coaching management and how the relationship of management to achievement were needed. This research uses a descriptive method with a quantitative approach. The sample used in this study was the Pencak Silat national team at the 2017 Sea Games 2017 and the 2018 Asian Games, totaling 30 athletes. The instrument used in this research was a questionnaire based on management theory from Bucher and Krotee. The results showed the team management with an overall average score of 173.13 entered in good category. The most prominent in the team management was controlling with a score of 132.43, followed by organizing, staffing with each an average score of 128.57 and 128.22. There was a significant and positive relationship between management and team achievements. Overall management contributed 66.3% in determining the success of team achievements. Whereas based on the indicators, the biggest contributors were staffing indicators (71.2%).

Keywords: management, pencak silat, achievement

1 Introduction

Sports is a form of planned and structured physical activity that involves bodily movements and intended to improve physical fitness [1]. Sport is a part of daily basic needs because it can increase person endurance [2]. In principle, the development of sports rests on three orientations, namely sports as recreation, sports as health and sports as achievements [3]. Indonesian Pencak Silat Achievement experienced ups and downs, in 2016 at the world championship held in Bali, Indonesia as the host managed to become the overall champion after winning 12 gold medals. But unfortunately the glorious achievement dived sharply when the 2017 Sea Games event in Kuala Lumpur, Malaysia. The Indonesian Pencak Silat Team was only able to bring home two gold, four silver and nine bronze. These results made the Indonesian Pencak Silat team failed to meet the target of 3 gold medals in the Southeast Asia sport multi event. Many factors have led to the drastic decline in the Indonesian Pencak Silat achievements in the multi event sport in Southeast Asia. From the study and analysis of the Coaching Team, the failure was largely influenced by non-technical factors.

In law no. 3 Year 2005 on National Sports System [4] explained that national sports coaching is inseparable from the role of education. While article 27 paragraph 4 states that "the fostering and development of sports achievements are carried out by

empowering sports associations, fostering national and regional sports coaching and organizing competitions in stages and in a sustainable manner". According to [25] the system of fostering sports achievement cannot be ignored that to achieve maximum results from a performance it is necessary to have a National Sports Development System that includes: ten policy pillars, including: 1) financial support, 2) sports institutions consisting from the structure and content of integrated sports policies, 3) marketing (participation), 4) fostering achievement, (promotion and identification of talent), 5) elite or top achievement (reward and sense of secure), 6) training facilities, 7) procurement and development of trainers, 8) national competition, 9) research, and 10) environment, media and sponsors.

The intensive and competitive coaching process is very tight competition, when it comes out as a winner it will become an athlete with extraordinary achievements and can be said to be an elite athlete [5]. In the laws of the Republic of Indonesia law number 3 of 2005 concerning the National Sports System [4], Achievement Sports are sports that foster and develop sportsman in a planned, tiered, and sustainable manner through competitions to achieve achievements with the support of sports science and technology. Achievement in sports is a complex matter, because it involves many factors, including internal factors such as physical and mental athletes, as well as external factors such as coaches, organizations, infrastructure and the environment [6]. Internal factors actually came from the quality of the athlete itself, where qualified athletes mean that in addition to having an innate talent in accordance with the demands of the sport, they also have good motivation and attitude so that they are ready to be developed to reach peak performance [7]. In the process of fostering sports achievements, synergy is needed from all elements [8]. One of the element is an experienced and educated trainer. Educated trainers are trainers who master training theories and understand the problems related to coaching [9] [10]. As a result of a coaching process carried out by educated trainers, the opportunity to achieve is far greater than the coaching process carried out by trainers who do not have the fundamentals of coaching. Good training can guarantee the implementation of the training process to achieve the desired performance [8]. [11] states "*The importance of coaching is self-evident. Coaches are responsible for developing athletes' mental, physical, technical, and tactical abilities, and in addition to all of these responsibilities, they are also expected to win*". The meaning of the statement is the importance of coaching that is clear. The coach is responsible for developing the athlete's mental, physical, technical, and tactical abilities, and for the purpose of all these responsibilities, the ultimate goal is to win.

From a variety of management theories the management functions are inventoried as planning, organizing, leadership, controlling and staffing [12]. Theoretically it can be said that sports performance organizations that can perform management functions properly can be expected to produce good achievements [13]. As said by [26] "management is the process by which key leadership personnel, so that the organization functions efficiently and effectively in achieving organizational goals." This shows that the role of organizational management in implementing its programs has the potential to produce achievements. Based on the effectiveness structure and organizational management practices reflected in the success or lack of the team. According to experts there are several functions, some of which according to [27] that "*the nine functions of sport management are planning, organizing, staff-*

ing, directing, motivating, leading, controlling, monitoring, and evaluating". In this study it is concluded that management is an art of science and process in carrying out organizational activities such as planning, organizing, directing and controlling by utilizing other organizational resources to achieve the stated goals.

2 Method

The method used in this study is a descriptive method with a quantitative approach to the research design described in the following table:

Table 1. Research Design

Management (planning , organizing , leadership , controlling , staffing)	Achievement
X	
X 1 : Sea Games 2017 pencak silat national team management	Y
X 2 : Asian Games 2018 pencak silat national team management	
X	Y

The respondents involved were the Indonesian Pencak Silat contingent at the *Sea Games 2017 & Asian Games 2018* with a total of 30 people who joined the team as athletes, coaches and management. In this study using a management questionnaire instrument according to book *Management of Physical Education and Sport* by [26] there were 40 statements using a 5 rating scale. With data analysis using SPSS Statistical Product and Service Solution (SPSS) for Windows version 20.0 with the steps of the statistical assumption test in the form of normality test then continued with the hypothesis test. In this study, researchers set the following data collection procedures:

- 1) Preparation Phase, consisting of the following steps:
 - (a) Submission title on lecturers, preparation of proposals and proposals seminar
 - (b) Trial questionnaire to different samples
 - (c) Submission of a research permit to and from the SPS UPI Sport Education department, then submitted to PB IPSI
- 2) Implementation Phase, consisting of steps of activities;
 - (a) Provision of questionnaires to each sample
 - (b) Interview by one athlete
- 3) Reporting Phase consists of steps of activities;
 - (a) Carry out processing and analysis of data that has been collected, using SPSS
 - (b) Making interpretations, making conclusions and recommendations of research results
 - (c) Prepare a complete thesis text.

3 Results and Discussion

Here are the results of the description of the data obtained by researchers at the time of conducting research.

Table 2. Overall Management Data Description

N	Min	Max	Average	SD	Amount
30	156	187	173,13	6.46	5,194

Table 2 shows the overall management score acquisition data. The data was obtained from 30 Respondents of Indonesian Pencak Silat National Team members at the Sea Games 2017 and Asian Games 2018 events. Overall the total score was 5,194, an average of 173,13, a standard deviation of 6.46 with a minimum score of 156 and a maximum score of 187 Data as a whole has not been able to provide a clear picture. Therefore, to provide a further picture, the researcher makes a score criterion using the norm reference assessment guideline (PAN). Based on the guideline of these criteria, the results of the criteria can be seen in Table 3

Table 3. Management Scores Criteria for Indonesian Pencak Silat National Team

No	Vulnerable Score	Criteria
1	183 +	A Very good
2	173 – 182	B Good
3	163 – 172	C Enough
4	158 – 162	D Less
5	157 and below	E Very less

Based on the management score criteria in Table 4.2, researchers can provide criteria on the management research data of the Indonesian Pencak Silat National Team. Referring to the overall data summary that has been shown in Table 4.1 earlier, shows the average, minimum and maximum scores. With reference to the score criteria that have been designed, the overall average score of 173.13 is included in the criteria of Good. While the minimum score with a score of 156 falls into the Very Poor criteria, and the highest score with a score of 187 falls into the Very Good criteria.

Then in table 4 the researchers poured national team management data based on assessment indicators.

Table 3. National Team Management Data Based on Assessment Indicators

Indicator	A	B	C	D	E
Amount	131.73	128.57	128.22	130.08	132.43
Average	4.39	4.28	4.27	4.33	4.41
Standard Deviation	0.38	0.23	.28	.22	0.25
Minimum	3.71	3.88	3.50	4	3.86
Maximum	5	4.75	4.88	4.75	5

Indicator Description:

- A = Planning
- B = Organizing
- C = Leadership
- D = Control
- E = Staffing

Table 4 shows the acquisition of management scores based on assessment indicators. It can be seen that the most prominent indicator in the management of the National Team is Personnel (E) with a total score of 132.43.

Furthermore, the planning indicator (A) with a score of 131.73. Control Indicator (D) obtained a score of 130.08. While the Organizing (B) and Leadership (C) and foreign indicators each score 128.57 and 128.22. The overall score of the indicators that get the highest score in the management of the Pencak Silat National Team is the staffing indicator. While the indicator that gets the lowest score is Leadership. The dependent variable in this study was the achievement of the Indonesian Pencak Silat National Team. This achievement data is reviewed from the results of the 2017 Sea Games 2017 and the 2018 Asian Games that have been completed which can be seen in the following table:

Table 4. Indonesian National Pencak Silat Team Achievement Data

Event	Medal		
	Gold	Silver	Bronze
Sea Games 2017	2	4	9
2018 Asian Games	14	0	1

Table 5 shows that the 2018 Asian Games event was the success of the Indonesian Pencak Silat national team which almost bought up all the gold medals competed, Indonesia only failed to win 2 gold from the 16 golds contested. Inversely proportional in the Sea Games 2017 Indonesian Pencak Silat national team won only 2 gold, 4 silver and 9 bronze.

Next in table 6 will show a statistical prerequisite test that is test data normality using the Liliefors test. The results can be seen in the following table:

Table 5. Data Normality Test

	<i>Shapiro-Wilk</i>	<i>Sig.</i>	Information
Management	0.905	0.081	Normal
Achievement	0.897	0.067	Normal

Table 6 shows the management data of Indonesian Pencak Silat national team with Shapiro-Wilk value = 0.905 and Sig. = 0.081 > 0.05 then the data is distributed normally. Indonesian National Pencak Silat national team data with Shapiro-Wilk value = 0.897 and Sig. = 0.067 > 0.05 can be interpreted as normally distributed data. Based on these results all data are declared normal. After conducting and obtaining the data normality test results, the next statistical test step is the hypothesis test.

In the research hypothesis testing is done through correlation and regression tests (*person correlation* and *linear regression*). Here are the results of testing the hypothesis can be seen in tables 7 and 8

Table 6. Correlation Test Results

R	Sig.	Information
0.795	0,000	Significant Relationship

Table 7. Regression Test Results

	R Square
0.795	.663

Seen that result in Table 7 was obtained the correlation coefficient (r) = 0,795 and sig on P_VALUE 0,000, it proves that there is a positive and significant relationship between management and the achievement of the team Pencak Silat Indonesia. This proves that the increase in scores on the variables of management will be followed by a rise in performance variables, and vice versa, meaning that if the management at every team better, it will be followed by achievements performance tend to be good. In addition, the additional analysis set forth in table 8 examines how big of the contribution of the management variable to the achievement variable, as evidenced by the coefficient of determination ($R\ square = 0.795$) obtained for 0,663, this can be interpreted that the management contributed 66,3% in determining the success of the Indonesian Pencak Silat national team achievements.

The results of testing the hypothesis indicate a high correlation value between management and the achievements of the Indonesian Pencak Silat National Team. In addition, further tests conducted using regression tests indicate the amount of management management's contribution to the national team's performance is fairly high. With these results provide further evidence on the relationship between the management team of the achievements of the team itself. Good management is directly proportional to the good achievements. However, these results are the evidence of overall management correlation. To provide a deeper explanation, researchers also

show the correlation test of each management indicator for achievement. These results can be seen in Tables 9 and 10:

Table 8. Correlation Test Management Indicators To Achievement

Indicator	R	Sig.	Information
Planning	0.826	0,000	Significant Relationship
Organizing	.804	0,000	Significant Relationship
Leadership	0.745	0,000	Significant Relationship
Control	0.790	0,000	Significant Relationship
Staffing	0.844	0,000	Significant Relationship

Table 9. Regression Test of Management Indicators for Achievement

Indicator	R	R Square
Planning	0.826	.682
Organizing	.804	0.646
Leadership	0.790	0.624
Control	0.745	0.555
Staffing	0.844	0.712

Tables 9 and 10 show the correlation and regression values of each management indicator on the achievements of the Indonesian Pencak Silat National Team.

- a. In the Planning indicator, the value of $r = 0.826$ and $\text{sig} = 0.000 < 0.05$, the relationship is significant, or it can be stated that there is a positive and significant relationship between the management of Planning on the achievement of the National Team. With the value of $r\text{-square} = 0.682$ means the relationship between management and planning of the achievements of the national team at 68.2 %.
- b. Organizational Indicators get $r = 0.804$ and $\text{sig} = 0.000 < 0.05$, then a significant relationship, or it can be stated that there is a positive and significant relationship between Organizing management and national team achievement. With the value of $r\text{-square} = 0.646$ means the relationship between the management organization of the achievements of the national team by 64.6 %.
- c. Leadership Indicators obtained a value of $r = 0.790$ and $\text{sig} = 0.000 < 0.05$ then a significant relationship, or it can be stated that there is a positive and significant relationship between leadership management on national team achievement. With the value of $r\text{-square} = 0.624$ defined the relationship between management and leadership to the team achievement of 62.4 %.
- d. Control Indicators get the value of $r = 0.745$ and $\text{sig} = 0.000 < 0.05$, the relationship is significant, or it can be stated that there is a positive and significant relationship between Control management on national team achievement. With the value of $r\text{-square} = 0.555$ defined the relationship between the management control of the achievements of the national team at 55.5 %.
- e. Staffing Indicators get a value of $r = 0.844$ and $\text{sig} = 0.000 < 0.05$ then a significant relationship, or it can be stated that there is a positive and signifi-

cant relationship between staffing management on national team achievement. With the value of $r\text{-square} = 0,712$ defined the relationship between the management staff of the achievements the national team at 71.2 %.

The results of the national team management correlation test based on each indicator to the achievements above show all indicators have a positive and significant relationship to the performance of the Indonesian Pencak Silat National Team. In addition, further tests using the regression test showed a significant contribution between each management indicator to the national team's achievements. Of all the management indicators, the staff indicator shows the highest value compared to the other indicators.

The results of the research that have been done provide an overview in the form of research data through the questionnaire management of the Pencak Silat national team. Based on data from research results that have been through the processing and analysis of data shows that on average the overall score obtained 173.13, which falls into either category. Based on management indicators shows that the most prominent in team management is staffing with a total score of 132.43. Furthermore, planning indicators with a score of 131.73. The Control Indicator gained a score of 130.08. While the organizing and leadership indicators each scored 128.57 and 128.22. Based on the questionnaire that has been distributed to the Indonesian Pencak Silat team, it shows that the indicator that gets the highest score is the staffing indicator. This was corroborated by research [14] that says "*original insights into the educational needs of sports science and management staff, which can inform practitioners who face increasing demands to work with such personnel, and raise sports organizations' awareness of Reviews their duty of care to employees and the factors that need to be managed*" the intent of the statement is the need for management staff educated sports science, which can provide information practitioners are facing increasing demands to work with team members that, and raise awareness of sports organizations about their care assignments to fellow teams and the factors that need to be considered and managed.

This illustrates that most of the teams have done quite well in terms of staffing. In other indicators, the results of the study show that the indicator that gets the lowest score is the leadership indicator. Leadership management functions to direct, influence, motivate, mentoring, conflict resolution and as a role model for team members, observing and evaluating the management process so that the planning made can achieve the expected results [15] [16]. Based on the results of an interview with one of the athletes, the manager sets a target and is delivered to his athletes, motivates each game, and the manager's communication with the athlete is very good. In connection with these results indicate that staffing management has been done well, while the leadership management of the Indonesian national team Pencak Silat is still lacking compared to other management indicators. Both of these results illustrate that the best composition that has been formed will not run well if it has not been supported by good leadership management. So that it can lead to achievement of goals that are not optimal. Every indicator in management is very important to be considered, especially in the management of a sports team [17] [18] [19].

The achievements of the Indonesian Pencak Silat national team at the 2017 Sea Games and the 2018 Asian Games in management is already well underway in ac-

cordance with the duties of his respective, excellent team of coaches, athletes and teams support incorporated in the Indonesian National Pencak Silat team. The results achieved in the 2017 Sea Games are more on the non-technical factors experienced by the Indonesian team such as cheating and decisions that are detrimental to the Indonesian team. Inversely proportional in the 2018 Asian Games Indonesia achieved very good success. Plus the appointment of Indonesia as a host that is fully supported by family, relatives and all Indonesian people who witnessed directly or through electronic media adds to the spirit of competing athletes to offer the best for the State of Indonesia. Regarding management in sports [20] states: *Management applied sport contributes to achieving full functionality of sports structures, the large masses of people, a plurality of means and skills, objectives and intentions. Management in sport helps to control possession and sports activities that can generate process efficiencies across the organization on.* The application of management in sports contributes in various ways, including the achievement of team goals [21]. Management in sports helps control processes that can have an impact on efficiency in all sports teams [22] [23]. The conclusion obtained in this research is the management of the Indonesian National Pencak Silat team in the good category.

Then the results showed that there was a significant and positive relationship between management and the achievements of the Indonesian national team. Thus it can be interpreted that the better the management, the better the achievement. Management is proven to be able to make a positive contribution to team performance by 66.3%. The results of this study are in accordance with the statement of [23] which states that "With proper management achievements will be achieved easily. All the elements that exist in supporting the sports achievements must be mutually supportive and sustainable. "Achievement is supported by good management and also supported by all elements that are mutually sustainable. Sports team achievement is the achievement of the goals of a team that competes in a particular competition. The team needs a good management to be able to achieve every goal set. In accordance with the statement of [26] *"Every individual belongs to formal organizations, through a democratic and cooperative approach to management, the individual can help in what has proved to be successful in the past"*. Democratic approach and cooperative towards management, individuals can help the success. In addition to management can help success, management is also a facility to achieve goals. [26] say that *"A knowledge of management facilitates the achievement of such aims."* Knowledge about management becomes a facility for achievement. In addition to the importance of management for achievement stated [23] which states that "To improve the absolute achievement of an organization has a main goal based on existing management functions". Each team must know and understand management functions and carry them out according to the stages that should be. [23] added that "Sports achievement is influenced by many factors, one of which is in sports management by sports organizations. The management functions include (planning, organizing, leadership, controlling, staffing). With the correct process and implementation in accordance with what is desired is an achievement, then all aspects relating to sports achievements must be fixed. "Management is one of the factors of a team or sports organization to achieve achievement [24]. Therefore, every team and or sports organization must pay more attention and carry out better management for maximum results.

4 Conclusion

In accordance with the results of data processing and analysis, it can be concluded that the management of the Indonesian Pencak Silat national team at the Seagames 2017 and Asian Games 2018 is included in the good category. Then there is a significant and positive relationship between management and achievement. It can be seen in this study that the management contribution made to the Indonesian Pencak Silat national team was 66.3%.

References

- [1] Flynn S, College GH, Jellum L, College GH, College GH, Moser A, et al. Concepts of Fitness and Wellness , 2nd Edition 2018.
- [2] Belski R, Forsyth A, Mantzioris E. Nutrition for Sport, Exercise and Performance 2019.
- [3] Bailey R, Neuroscience E. Sport in Society Sport , physical activity and educational achievement – towards an explanatory model 2017.
- [4] Kemenpora. UU Sistem Keolahragaan Nasional 2005.
- [5] Mallett CJ, Hanrahan SJ. Elite athletes: why does the ‘fire’ burn so brightly? Psychol Sport Exerc 2004;5:183–200.
- [6] Shahidian S, Sampaio J, Leite N. The Importance of Sports Performance Factors and Training Contents From the Perspective of Futsal Coaches 2013;38:151–60.
- [7] Adling RB. Importance of sports psychology in physical education and sports 2017;2:215–8.
- [8] Bloom GA, Falcão WR, Caron JG. Coaching high performance athletes : Implications for coach training 2016.
- [9] Griffiths K. Personal coaching: a model for effective 2005;1:55–65.
- [10] Joo B-K (Brian). Executive Coaching: A Conceptual Framework From an Integrative Review of Practice and Research. Hum Resour Dev Rev 2005;4:462–88.
- [11] Becker AJ. It ’ s Not What They Do , It ’ s How They Do It : Athlete Experiences of Great Coaching 2009;4:93–119.
- [12] Pal DK. Management Concepts and Organizational Behaviour 2011:1–720.
- [13] Gunnigle P, McDonnell A. Performance management 2008.
- [14] Arnold R, Collington S, Manley H, Rees S, Soanes J, Williams M, et al. “ The Team Behind the Team ”: Exploring the Organizational Stressor Experiences of Sport Science and Management Staff in Elite Sport. J Appl Sport Psychol 2017;0:1–20.
- [15] Michael A. Mentoring and Coaching 2008:1–19.
- [16] Kolzow DR. Leading from within: Building Organizational Leadership Capacity Authored by : Table of Contents. 2014.
- [17] Jones NMP, Mellalieu SD, James N. Team performance indicators as a function of winning and losing in rugby union. Int J Perform Anal Sport 2004;4:61–71.
- [18] Gabcanova I. Human Resources Key Performance Indicators. J Compet 2012;4:117–28.
- [19] Serra P. Sociology of Sport. 2015.
- [20] Cucui GG, Cucui IA. Analysis of the management system football clubs (junior) 2016;9.
- [21] Kieran K. The application of goal setting in sport 2017.
- [22] Ratten V. The impact of sports on team performance management. Team Perform Manag An Int J 2009;15:97–9.
- [23] Kasale LL, Winand M, Robinson L. Performance management of National Sports Organisations: a holistic theoretical model. Sport Bus Manag An Int J 2018;8:469–91.
- [24] Boakye EO. The impact of teamwork on employee performance 2015.

Physical Activity Trends in Millennial Generation: Kill the Body Fat

Linda Desrianda Tamher¹, Giat Akbar Maulana², Mustika Fitri³, Pipit Pitriani⁴
{lindadesrianda@upi.edu¹, giat.akbar.maulana@gmail.com², mustikafitri@upi.edu³}

Universitas Pendidikan Indonesia, Bandung, Indonesia¹²³⁴

Abstract. Lack of physical activity and unhealthy lifestyles is no stranger to the current millennial generation. so many of them are gaining weight until they are obese. One of the characteristics of obesity is an increase in body fat percentage. Physical activity is a good way to reduce body fat percentage. The aim of the study was to examine physical activity trends in the millennial generation to decrease body fat. It used a pre-posttest two treatment design, with 22 samples of obese women, and divided into aerobic dance group and Zumba group. It was conducted 3 times in a week along 12 weeks, with intensity of 65% - 85% based on maximum heart rate. The result of this study showed that aerobic dance and Zumba had an effect on body fat percentage.

Keywords: physical activity, body fat percentage, obese women.

1 Introduction

Obesity is one of the serious diseases in the world [1]. More than 312 million people obesity [2], with a percentage of 13% of adults over 18 years old [3], than adolescence 12-19 years old [4]. Increasing age can decrease muscle mass and increased body fat mass [5].

Obesity can be seen from the body composition [6]. One characteristic of obesity has increased the bodyweight, indirectly increasing the percentage of body fat [7]. The normal category range body fat for men is 8.0 – 19.9% , and for women is 21.0 – 32.9%, and high category for men is 20.0% - 24.9%, and for women is 33% - 38.9%, very high category for men is > 25% and for women > 39.0% [8]. More severe obesity occurs for women than men [9]. The significant research for different percentage obese men 8 – 30% and for women 8 – 52% on Southeast Asia [10]. Increased prevalence of obesity worldwide by reaching 18% in men and exceeding 21% in women and severe obesity will exceed 6% in men and 9% in women [11]. Women tend to exhibit poorer complications than sedentary lifestyles than men [12]. Obesity makes more diseases like diabetes type II, hypertension, chronic disease, dyslipidemia, coronary heart disease, and certain types of cancer [11], reproductive disorder [13], even until mortality [14]. Obesity has more effect on women than men [9].

Some studies have analyzed factors that are at risk in adulthood, such as increasing consumption of unhealthy foods, decreased physical activity, resulting in the development of obesity [4]. An unhealthy lifestyle is the main factor in obesity

[1]. Lack of physical activity is assumed with the global development and due to lifestyle changes, can negatively affect personal health and society [15] It is known that lack of exercise, unhealthy lifestyles, and poor nutrition causes major health problems such as hypertension, obesity, muscular atrophy, and postural disorders [15]. Lack of physical activity has been linked to increased obesity through frequent sit-down and a lack of physical activity [16] The lack of this activity is caused by the work activity that demands them to dwell in a place for several hours so that it is less moving, and the lack of a walk although the intended place is not too far away [17]. A sedentary lifestyle has a negative effect on health and quality of life [5].

Physical activity programs are one of the most appropriate ways to achieve health benefits [18], increased memory, and chronic disease reduction [19]. Physical activity affects muscle performance and energy expenditure to maintain body composition and reduce the risk of obesity [20]. Increasing physical activity in the form of aerobic exercise leads to increased aerobic capacity in the body [21], thus making the body ideal [22]. It is recommended for every teenager and adult to engage in moderate-intensity physical activity for 60 minutes daily to prevent hypertension and obesity [23]. The duration of > 30 minutes is a mild intensity zone by using an energy system from oxidation, resulting in an anaerobic bioenergetic contribution of 5-2% Alaktasid and 95 – 98% aerobic. It is therefore suggested that physical activity for durability is done with a long duration with mild intensity, so it is called as Aerobic exercise [24]. Moderate - to high - intensity aerobic exercise significantly reduced body fat in obese boys and girls [6].

Aerobic exercises describe positive changes in body composition, such as a reduction in Body mass index (BMI) and body fat percentage (BF%) [25]. Aerobic exercise can improve insulin action, improve lipid profile, glycemic levels, blood pressure, reduce the risk of cardiovascular disease, lower body weight, mortality reduction, prevent diabetes complications and improve the quality of life of diabetics if done continuously [26]. Aerobic exercise is one sport that emphasizes a series of repetitive movements and a long duration and nonstop because it refers to the uptake of energy through fat (Giriwijoyo, 2017). Aerobic sports include walking, jogging, swimming, cycling and aerobic gymnastics [27], [28]. An interesting and exciting physical activity today is aerobic dance (Ahmad, Amir, & Rosli, 2015), such as aerobics dance and zumba.

Now, Zumba® is regarded as one of the most popular high-impact physical activities among women [29]. Zumba exercises are an uplifting, effective, easy-to-follow dance fitness party, inspired by the Latinos, burning calories that drive millions towards excitement and health [30]. Scientific research on the benefits of Zumba in healthy women has shown many positive things, the effect of this type of exercise on body composition and physical fitness (Delextrat, Warner, Graham, & Neupert, 2016). The application of Zumba Fitness® seems to be as effective as Zumba Fitness® Weight-loss Reduction training [31]. Besides, the average energy expenditure of zumba sports is 369 kcal for each class (duration of approximately 40 minutes), therefore Zumba meets the recommendations of the American College of Sport Medicine of sports at all ages (Tugusi et al., 2018).

In this study to know the benefits of aerobic gymnastics and Zumba on decreased body fat percentage. The study aims to identify the influence of physical activity on body fat percentage. Researchers have hypothesized that in 12 weeks of physical activity will affect body fat percentage.

2 Materials and Methods

2.1 Participants

This study used experimental research with Pretest-Posttest Two Treatment Design design. The study subject of 22 obese women in the S Fitness Center. The subject has the criteria: (1) active member, (2) has Bodyfat > 30%-45%. (3) Have a commitment and passion, (4) have no history of chronic diseases.

2.2 Study Design

The subject is divided into two groups given different trainings. Group 1 was given an aerobic gymnastics training and Group 2 was given Zumba gymnastics. The entire subject performs an initial test before training and the final test after completion of the last training. Training is done every 3x a week (Tugusi, Manca, Bergamin, & Blasio, 2018) for 12 weeks (Delextrat et al., 2016). With an intensity of 65%-85% (Giriwijoyo, 2017), according to the maximum heart rate of each sample.

2.3 Exercise Method Protocol

Each-each training program in aerobic gymnastics and Zumba given a division of 10 minutes of heating, 45 minutes of core movement according to the intensity needed, 5 minutes of cooling, of course this intensity is adjusted to the situation and condition of the subject.

2.4 Measured Variables

- Omron Karada Scale

This tool serves to measure body fat, body age, BMI, Visceral fat, Skeletal muscle, and resting metabolism. The way is to focus the data that has been input on tools such as gender, age, height, and weight. How to include weight, height, and age in the appliance, the subject of standing on the position of the upright straight above, while holding the grip of the appliance, then the result will be legible on the device.

- Check Pulse

Pulsing the pulse in the left hand, or on the neck or in the chest using the right palm of the hand. Performed for 6 seconds, the result is in multiply 10. To be accumulated in 1 minute.

- Roll meter

This roll meter is used to measure the resulting decline after conducting exercise programs on the limbs, such as the arms, chest, abdomen, thighs, buttocks, and waist in cm units.

2.5 Data Analysis

Analysis of this research data using the Statistical Package for Social Science (SPSS) Ver. 16.0 application. This study using parametric statistics with the analysis of Paired Sample T-Test

3 Results and Discussions

Based on the results of data from preliminary tests, aerobic gymnastics and Zumba training for 12 weeks and the final Test with the results of the cycle data period:

Table 1. Average and standard deviation group Aerobic Dance And Zumba Based On Body Fat Percentage

Group	pretest		posttest		Paired sample	
	Mean	Stdev	Mean	Stdev	T-Test (2-sig)	Sig
Aerobic dance	38%	2%	31%	2.02%	0.014	0.007
Zumba	37%	2.5%	30.5%	3.6%	0.050	0.0025

Table 1 explains the average initial test of the body fat percentage of aerobic gymnastics group 38% with a standard deviation of 2%, while the average test of the initial Zumba group is 37% with a standard deviation of 2.5%. After the training conducted aerobic gymnastics and Zumba there is an average final test of the body fat percentage of aerobic gymnastics group is 31% with the standard deviation of 2.02%, while the average test of the end of the Zumba group is 30.5% with the standard deviation of 3.6%.

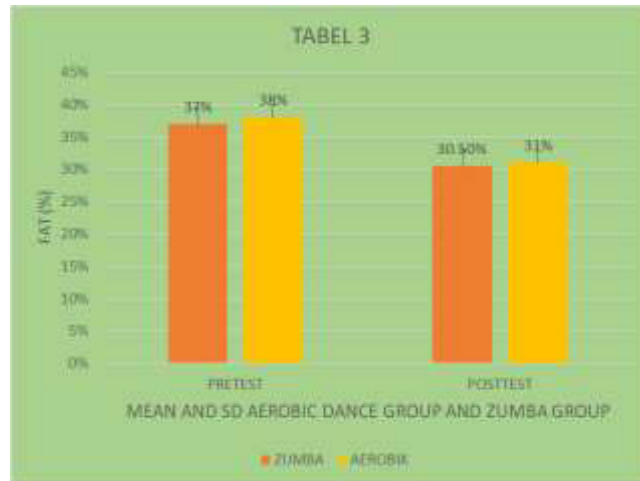

Fig. 1. Comparison Of Body Fat Percentage Of Aerobic Gymnastics And Zumba Group (Average Data \pm SD)

Based on Figure 3, decreased body fat percentage of aerobic gymnastics Group by 7%, and decreased body fat percentage in Zumba group amounted to 6.5%. Result of data calculation using Paired sample T-Test shows in aerobic gymnastics group $SIG (0.0007) < 0.05$ and on Zumba $SIG Group (0.0025) < 0.05$. These results indicate there is a significant influence on aerobic gymnastics exercises and Zumba against decreased body fat percentage.

Based on the results of research obtained there is a significant influence for physical activity of both aerobic gymnastics and Zumba against decreased body fat percentage. The study conducted for approximately 3 months with 36 sessions resulting in a decrease in the results of body composition measurements in each sample. Based on the data in the tables above it is explained that body composition ranging from body weight, body mass index, fat percentage, muscle to the measurement of the body showed a decrease.

Decreased fat percentage there was a decrease in aerobic gymnastics group 1.06% while the Zumba group amounted to 1.49%. Zumba Group is seen more of his decline in aerobic gymnastics group of 0.43%. In addition, weight loss and body fat are also affected by the results of the body mass index obtained by each sample. This decline is caused by aerobic and Zumba gymnastics activities conducted for 60 minutes each meeting, aerobic gymnastics and Zumba is a group of physical activity aimed at losing weight, body fat and increase endurance [32].

The data of the decline when compared between aerobic gymnastics and Zumba groups is more or less the same data. But it looks a little bigger the decline is in the Zumba group. This is caused by Zumba as an effective exercise program for improving body composition, aerobic capacity, and general health, it can be a very interesting and effective program to encourage physical activity [31]. So it can be done vigorously.

Aside from aerobic and Zumba gymnastics, physical activity such as fast roads, jogging, stair climbing, basketball, racket sports, football, lap laps, skating, lawn mowing, cycling, and dancing [33] is an aerobic exercise that is recommended for adults to lower body weight, mass index and body fat. Without realizing daily activities can be used as physical activities that can reduce body mass index, body fat, and body Betar, such as playing, working, traveling, recreation etc [33]. However, if you want maximum results, it is advisable to carry out physical activity with long duration and moderate to high intensity [24].

The physical activity of aerobic and Zumba gymnastics almost has similarities to the results obtained. However, to achieve maximum results is better combined with nutritional intake activity [31]. Because of this body composition can be modified using physical activity and nutritional intake [34]. This is important because the optimal body composition is capable of maintaining the health of cardiometabolic diseases [35]. In addition, changing lifestyles for the better is also one way to destroy the risk of obesity and future Diabetes [36]. Physical activity is important in energy balance and recovery for obese people, but it is better balanced with the regulation of the calories consumed [37].

In fact, this research can result in a reduction in body fat percentage which is even greater in body composition, but there are limited researchers in the study, such as long research time, less conducive situation and condition, the condition of each sample that can not be predicted. In this study it is better for researchers to then be able to consider the situation and conditions in the study, the condition of each sample, and add things to be researched such as nutrition, genetic, daily activities, history of disease and hormones, because it is a factor that affects the body composition.

4 Conclusions and Suggestions

In this study obtained a significant reduction of physical activity such as aerobic gymnastics and Zumba for decreased body fat percentage.

References

- [1] N. Kapoor *et al.*, "Normal Weight Obesity : An Underrecognized Problem in Individuals of South Asian Descent," *Clin. Ther.*, vol. 41, no. 8, pp. 1638–1642, 2019.
- [2] James WPT, R. N, and R. Leach, "The obesity epidemic, metabolic syndrome and future preventive strategies," *Eur J Cardiovasc Prev Rehabil*, vol. 11, pp. 3–8, 2004.
- [3] WHO, "Obesity and overweight," 2019. [Online]. Available: <http://who.int/news-room/fact-sheets/detail/obesity-and-overweight>. [Accessed: 06-Nov-2018].
- [4] C. Ruano, E. Lucumi, J. Albán, S. Arteaga, and M. Fors, "Obesity and cardio-metabolic risk factors in Ecuadorian university students," *Diabetes Metab. Syndr. Clin. Res. Rev.*, vol. 1871–4021, no. 1003, p. 5, 2018.
- [5] R. Leirós-rodríguez, V. Romo-pérez, I. Pérez-ribo, and L. José, "A comparison of three physical activity programs for health and fitness tested with older women : Benefits of aerobic activity , aqua fitness , and strength training," *J. Women Aging*, vol. 00, no. 00, pp. 1–13, 2018.
- [6] Henry C. Lukaski, *Body Composition*. New York, 2017.

- [7] B. P. Hammond, A. M. Brennan, and R. Ross, "Exercise and Adipose Tissue Redistribution in Overweight and Obese Adults," in *Body Composition*, H. C. Lukaski, Ed. US: CRC Press, 2017, pp. 109–128.
- [8] Omron Healthcare, *Instruction Manual Full Body Sensor Body Composition Monitor and Scale*. 2008.
- [9] O. Pickett-blakely and L. Uwakwe, "O b e s i t y in Wo m e n and Reproductive Health and Disease Management," *Gastroenterol. Clin. NA*, vol. 45, no. 2, pp. 317–331, 2016.
- [10] C. N. Rachmi, M. Li, and L. A. Baur, "Overweight and obesity in Indonesia : prevalence and risk factors d a literature review," vol. 7, 2017.
- [11] R. An, C. Guan, J. Liu, N. Chen, and C. Clarke, "Annals of Epidemiology Original article Trade openness and the obesity epidemic : a cross-national study of 175 countries during 1975 e 2016," *Ann. Epidemiol.*, vol. 37, pp. 31–36, 2019.
- [12] K. A. Ahrens *et al.*, "Annals of Epidemiology The effect of physical activity across the menstrual cycle on reproductive function," *Ann. Epidemiol.*, vol. 24, no. 2, pp. 127–134, 2014.
- [13] N. Sermondade *et al.*, "Female obesity is negatively associated with live birth rate following IVF : a systematic review and meta-analysis," pp. 1–13, 2019.
- [14] A. Talmor and D. Bruce, "Female Obesity and Infertility," *Best Pract. Res. Clin. Obstet. Gynaecol.*, vol. xxx, no. 5, pp. 1–9, 2014.
- [15] F. Kiyici, "Metabolic and lipid profile of middle-aged sedentary women doing aerobic exercise plus weightlifting," *Procedia - Soc. Behav. Sci.*, vol. 116, pp. 3935–3939, 2014.
- [16] A. E. Hardman and David J. Stensel, *Physical Activity And Health*. USA And Canada: Routledge, 2003.
- [17] S. Pengpid and K. Peltzer, "Diabetes & Metabolic Syndrome : Clinical Research & Reviews Underweight and overweight or obesity and associated factors among school-going adolescents in fi ve ASEAN countries , 2015," *Diabetes Metab. Syndr. Clin. Res. Rev.*, vol. 13, no. 6, pp. 3075–3080, 2019.
- [18] Jennifer *et al.*, "Effects of Muay Thai training frequency on body composition and physical fitness in healthy untrained women," 2017.
- [19] C. Shin, Y. Lee, and M. Belyea, "Physical activity , benefits , and barriers across the aging continuum," *Appl. Nurs. Res.*, vol. 44, no. February, pp. 107–112, 2018.
- [20] S. S. Gropper *et al.*, "The impact of physical activity on body weight and fat gains during the first 3 years of college," *Int. J. Heal. Promot. Educ.*, vol. 50, no. 6, pp. 296–310, 2012.
- [21] M. Molina, O. López, J. Ma, M. Reyes, R. Burgos, and L. G. De, "Influence of physical activity and dietary habits on lipid profile , blood pressure and BMI in subjects with metabolic syndrome," 2011.
- [22] F. J. Amaro-gahete, L. Jurado-fasoli, J. R. Ruiz, and M. J. Castillo, *Effects of different exercise training programs on body composition: a randomized control trial Different exercise program body composition. .*
- [23] E. K. Towner *et al.*, "Physical Activity as a Predictor of Changes in Systolic Blood Pressure for African-American Adolescents Seeking Treatment for Obesity," *J. Adolesc. Heal.*, vol. 65, no. 3, pp. 430–432, 2019.
- [24] T. O. Bompa and G. G. Haff, *Periodization : Theory And Methodology Of Training*, Fifth Edit. 2009.
- [25] D. A. S. Silva, E. L. Petroski, and A. Pelegrini, "Effects Of Aerobic Exercise On The Body Composition And Lipid Profile," vol. 36, no. 2, pp. 295–309, 2014.
- [26] M. Saghebjo, Z. Nezamdoost, F. Ahmadabadi, and I. Saffari, "Diabetes & Metabolic Syndrome : Clinical Research & Reviews The effect of 12 weeks of aerobic training on serum levels high sensitivity C-reactive protein , tumor necrosis factor-alpha , lipid pro fi le and anthropometric characteristics in middle-age women patients with type 2 diabetes," *Diabetes Metab. Syndr. Clin. Res. Rev.*, vol. 12, no. 2, pp. 163–168, 2018.

- [27] M. Rizka, "Pengaruh Latihan Jalan Kaki Terhadap Kebugaran Jasmani Lansia Di Puskesmas Sungai Aur Kabupaten Pasaman Barat," *Stamina*, vol. 1, pp. 206–218, 2018.
- [28] H. Hürter *et al.*, "Best Practice & Research Clinical Endocrinology & Metabolism Prevention of pre-eclampsia after infertility treatment : Preconceptional minimalisation of risk factors," vol. 33, pp. 127–132, 2019.
- [29] E. Ubago-guisado, S. Javier, and S. Vila-maldonado, "Effects of Zumba ® and Aquagym on Bone Mass in Inactive Middle-Aged Women," *Medicina (B. Aires).*, vol. 55, no. 23, pp. 1–10, 2019.
- [30] S. Barene, P. Krustrup, S. R. Jackman, O. L. Brekke, and A. Holtermann, "Do soccer and Zumba exercise improve fitness and indicators of health among female hospital employees? A 12-week RCT," *Scand. J. Med. Sci. Sport.*, pp. 1–10, 2013.
- [31] Y. Barranco-ruiz, M. Guerendiain, and E. Villa-gonz, "Clinical Nutrition Body composition and dairy intake in sedentary employees who participated in a healthy program based on nutrition education and Zumba," *Clin. Nutr.*, no. October, pp. 1–10, 2018.
- [32] M. F. Ahmad, M. Amir, and A. Rosli, "Effects of Aerobic Dance on Cardiovascular Level and Body Weight among Women," *Int. J. Medical, Heal. Biomed. Bioeng. Pharm. Eng.*, vol. 9, no. 12, pp. 874–882, 2015.
- [33] N. A. for S. and P. Education, *Physical Education for Lifelong Fitness*, Third. Human Kinetics, 2011.
- [34] A. J. Alford, M. White, L. Lockwood, A. Hallahan, and P. S. W. Davies, "Body composition , dietary intake and physical activity of young survivors of childhood cancer," *Clin. Nutr.*, no. March, pp. 1–6, 2018.
- [35] S. Haldar, S. C. Chia, and C. J. Henry, *Body Composition in Asians and Caucasians : Comparative Analyses and Influences on Cardiometabolic Outcomes*, 1st ed., vol. 75. Elsevier Inc., 2015.
- [36] M. Skalska, "Body composition , physical fitness , physical activity and nutrition in Polish and Spanish Composition corporelle , condition physique , activité physique," 2019.
- [37] S. E. Crouter, C. Salas, and J. Wiecha, "Effects of an afterschool community center physical activity program on fitness and body composition in obese youth," *J. Sports Sci.*, vol. 0414, no. July, 2016.

Median Survival of Clinical Condition Improvement Factors among Patients with Type 2 Diabetes Mellitus in Semarang City, Indonesia

Lukman Fauzi¹, Sri Ratna Rahayu², Anisa Wahyu Hardini³, Lindra Anggorowati⁴

{lukman.ikm@mail.unnes.ac.id¹, sratnarahayu@mail.unnes.ac.id²,
anisawahyuh@gmail.com³}

Universitas Negeri Semarang, Semarang, Indonesia¹²³⁴

Abstract. Type 2 Diabetes Mellitus (DM) cases in Tugurejo Regional Hospital Semarang City increased up to 45,87% in 2018. Length of stay of patient in Tugurejo Hospital was 28.74% not in accordance with INA-DRG standards. It meant the rate of clinical condition improvement inpatient was slow. The aim was to determine median survival of clinical condition improvement factors among patients with type 2. It was historical cohort study by observing the medical records. The sample in this study was 70. The result median survival of age variable (<40 years old was 5 days), hypertension status (normal blood pressure was 6 days), obesity (normal body mass index was 6 days), blood glucose level (normal was 5 days), diet of DM (diet was 6 days), and level of dependency (self-care was 6 days).

Keywords: median survival, clinical condition, diabetes.

1 Introduction

Non-Communicable Disease (NCD) still becomes a public health problem, both globally, nationally and locally. About 70% of the total deaths in the world and more than half the burden of disease is Diabetes Mellitus [1]. Diabetes Mellitus (DM) caused by high blood glucose levels due to disorders of the pancreas and insulin. Based on WHO, in 2016 DM in the 7th rank causes of world death. In Indonesia, it is estimated that in 2030 there will be 21.3 million people with DM. DM in the third-ranking after stroke and Ischaemic Heart Disease (IHD), with increase from 2013 about 6.9% to 8.5% in 2017 [2].

In Central Java, DM was ranked second highest disease after hypertension is about 20.57% [3]. Semarang City was highest ranked of type 2 DM about 53.349 cases in Central Java Province in 2018 [3]. Based on Profil Kesehatan Kota Semarang 2018, the pattern of top 10 hospital diseases in the Semarang City in 2017 ranked sixth was DM by as many as 3429 cases and increased fifth ranked in 2018 with 3156 cases [4]. The prevalence of type 2 DM cases in Tugurejo Regional Hospital Semarang City in 2017 about 45.22% and increased in 2018 about 45.87%.

Research on the factors that influence the incidence of type 2 DM in Tugurejo Regional Hospital has been carried out with a variety of variables, while it is also necessary to know the survival rate of improvement in the clinical condition of type 2 DM by applying statistical methods to determine the factors that correlated with the recovery rate. This research used analysis survival. Survival analysis is a method related to time, starting from the time origin or start point to the occurrence of a specific event (failure event/end point) [5]. Survival analysis requires data that is survival time. There are three things that must be considered in determining the survival time, namely the time origin or start point, the definition of failure event, and the clarity of the measurement scale [6].

Length of Stay (LOS) shows the correlation with the improvement of the patient's clinical condition. The longer LOS patient have, the slower the patient will experience improvement in clinical conditions. In the previous research at Tugurejo hospital in 2014 about type 2 DM disease, it was stated that the standard in INA-DRG the length of stay for DM cases was 7-20 days with the highest percentage of length of stay was 8 days and the lowest 1 day, and based on LOS patients were obtained as many as 28.74% which is not according to INA-DRG standard [7].

The survival time in this study used recovery time, started from diagnosis with type 2 diabetes and undergoing hospitalization in a hospital until it is declared to have improved clinical conditions and is allowed to go home based on the decision of the doctor specialist. Median survival is the time when 50% of subjects experience an event [8].

Previous research conducted at Wangaya Hospital in Denpasar using a survival analysis explain that in the period of 1 to 29 days from the time DM patients were hospitalized, the chances of patients surviving for less than 5 days were 0,5 and at the end of treatment, the chances of survival decreased to 0,039, as well as variables that have a significant effect on statistics including gender, blood sugar status, and other diseases [5]. Another research on the survival analysis of DM sufferers at Makassar Bhayangkara Hospital, the factors that have a significant influence on survival time are age and blood sugar levels are bound to time, where each individual who is less than 45 years old has a risk of failure of 0,015 times less than with patients over the age of 45 years and individuals with high blood sugar levels have a risk of failure of 1,128 times greater than patients who have low and normal blood sugar levels [9]

2 Methods

The research was conducted in Tugurejo Regional Hospital Semarang City. This research conducted for four months since December 2019 to March 2020. The total population in this research in January-December 2018 is 206 patients. The inclusion criteria patients who are diagnosed with type 2 DM and hospitalization at Tugurejo Regional Hospital Semarang City in 2018 based on information from the medical record and covering all variables. The exclusion criteria are patients who died and discharged from the hospital without permission from the hospital. In determining the number of samples using simple random technique and the samples were 70.

This research used was observational analytic and historic cohort design. Sources of data in this research was from medical records. The research instruments

used in this research was observation sheet to help transfer information from medical record. The steps of data analysis in this study are as follows:

1. Recapitulate secondary data from type 2 DM patients.
2. Identify data characteristics of type 2 DM patients.
3. Test the proportional hazard assumption by using the Kaplan Meier curve to find out the median survival and chance of survival in DM patients.

This study uses survival analysis with looking Kaplan Meier curve to determine the dependent variable and independent variable.

The dependent variable in this study is the survival time of patients with type 2 diabetes, with the following conditions:

- a. Start point (time origin), is the time when the initial patient admitted Tugurejo Hospital Semarang for hospitalization.
- b. Ending event of interest is a condition when patients with type 2 DM are declared to have improved clinical conditions and are allowed to go home based on the decision of the doctor specialist.
- c. The measurement scale of this study is in units of days.

The category of dependent variable divided into event and censor. Event if patient reach the goal of the patient being hospitalized and allowed to go home less than the period of time or median survival, censor if Patients who die, or lost to follow-up, or fail or are treated for more than equals the specified time period or median survival. The median survival used in this research was 8 days [10]. The independent variables in this study were sex, age, hypertension status, obesity, blood glucose level, diet of DM, neuropathy, hyperglycemia, pain, diabetic ulcers, and level of dependency. These variables are of the categorical type with two categories.

3 Result and Discussion

Patient characteristics are presented in several tables below.

Table 1. Patient characteristics.

Patients characteristics	<i>n</i>	Percentage (%)
Sex		
- Male	19	27.2
- Female	51	72.8
Age		
- <40 years old	14	20.0
- ≥40 years old	56	80.0
Occupation		
- Civil servants	3	4.2
- Labor/employee	5	7.1
- Entrepreneur	12	17.5
- Retired	17	24.1
- Does not work	33	47.1

Based on the table 1, the number of female patients were 51 patients (72.8%) is higher than that of male patients were 19 patients (27.2%). From 70 respondents,

respondents aged <40 years old were 14 patients (20.0%), while respondents aged ≥ 40 years old were 56 patients (80.0%). The distribution of 70 respondents based on occupation, the most occupation by patients not working were 33 patients (47.1%) and the least frequency the types of occupation were civil servants were 3 (4.2%).

Table 2. Clinical condition improvement factors of DM.

Variable	Category	Censor		Event		Total	
		n	%	n	%	n	%
Sex	Male	9	34.6	10	22.7	19	27.1
	Female	17	65.4	34	77.3	51	72.9
Age	<40 y.o.	0	0.0	14	31.8	14	20.0
	≥ 40 y.o.	26	100.0	30	68.2	56	80.0
Hypertension status	Normal	6	23.1	36	81.8	42	60.0
	Prahypertension/ Hypertension	20	76.9	8	18.2	28	40.0
Obesity	Normal	4	15.4	29	65.9	33	47.1
	Overweight/ obes	22	84.6	15	34.1	37	52.9
Blood glucose level	Normal (<200)	3	11.5	26	59.1	29	41.4
	Diabetes (≥ 200)	23	88.5	18	40.9	41	58.6
Pain	No	23	88.5	40	90.9	63	90.0
	Yes	3	11.5	4	9.1	7	10.0
Hyperglycemia	No	23	88.5	43	97.7	66	94.3
	Yes	3	11.5	1	2.3	4	5.7
Diet of DM	Yes	6	23.1	38	86.4	44	62.9
	No	20	76.9	6	13.6	26	37.1
Neuropathy	No	5	19.2	8	18.2	13	18.6
	Yes	21	80.8	36	81.8	57	81.4
Diabetic ulcers	No	10	38.5	20	45.5	30	42.9
	Yes	16	61.5	24	54.5	40	57.1
Level of dependency	Self Care	7	26.9	41	93.2	48	68.6
	Intermediate Care, Partial Care, and Total Care	19	73.1	3	6.8	22	31.4

Based on table 2, from of 70 type 2 DM patients, female patients experienced more events (77.3%) and censors (65.4%) than male patients. Patients with age ≥ 40 years old were highest in the event (68.2%) and censors (100%). In hypertension status, the highest censor status was in prahypertension/ hypertension patients (76.9%) and the highest event status was patients with normal blood pressure (81.8%). Similarly, in obesity and blood glucose levels, the highest cases of censors were patients with overweight/obesity (84.6%) and patients with diabetes (88.5%), whereas cases of the highest event were patients with normal weight (65.9%) and normal blood sugar levels (59.1%). In the variable pain and hyperglycemia the highest cases of events and censors are patients without pain and without hyperglycemia. Patients with neuropathy and diabetic ulcers occupy the highest event and censor status. As for the diet of DM, the highest case of event was without diet (76.9%) and the highest censor of patients on the DM diet (86.4%). At the level of dependency variable, intermediate care, partial

care, and total care occupy the highest censor status (73.1%) and self care in the highest event status (93.2%).

Median survival is the time when 50% of subjects experience an event. Median survival can be known by drawing a horizontal line from the y-axis at the point of 50% to cross the survival line. Based on the result of Kaplan Meier Curve variables that are not tangent are age, hypertension status, obesity, blood glucose level, diet of DM, and level of dependency.

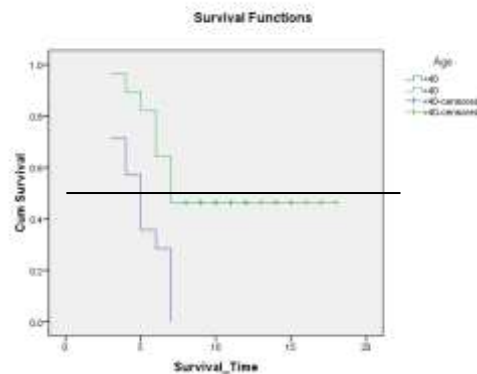

Fig. 1. Kaplan Meier curve of age.

Based on the age variable, median survival at <40 years old is 5 days, meaning that as many as 50% of type 2 DM patients aged <40 years old need 5 days to experience clinical conditions improvement. The median survival at the age of ≥ 40 years old is 7 days, it can be concluded that 50% of DM patients aged ≥ 40 years old need 7 days to experience clinical conditions improvement. Otherwise stated, type 2 DM patients who aged <40 years old need faster time to experience improvement in clinical conditions than those who have obesity aged ≥ 40 years old.

The age variable from this study, in line with what was stated by the International Diabetes Federation, that as many as 90-95% of people with type 2 diabetes are generally over 40 years old [11]. At the age of more than 40 years, is caused by the age at which an intolerance of glucose begins to occur. The existence of the aging process causes reduced ability of β cells in the pancreas to produce insulin [12]. With age, the ability of a person's immune system to fight viruses and destroy fungi and bacteria is reduced [13]. A high proportion of inpatients had complications, which may reflect their older age and long duration of DM [14]. DM type 2 in the elderly is accompanied by functional disability, some complications and mortality so that DM management for the elderly is very necessary [15].

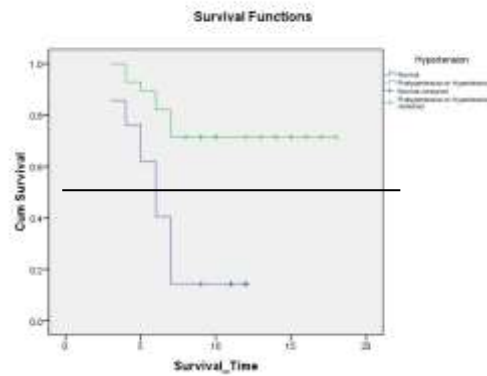

Fig. 2. Kaplan Meier curve of hypertension status.

Based on the variable hypertension status, median survival at normal blood pressure is 6 days. It can be concluded that 50% of DM patients who have normal blood pressure need 6 days to experience clinical conditions improvement. Nevertheless, this is different in prahypertension/hypertension people that shows 50% of DM patients who have need days exceeding observation time. In the other words, type 2 DM patients who have normal blood pressure need faster time to experience improvement in clinical conditions than those who prahypertension/hypertension.

The most common type of disease suffered as a complication of type 2 DM is hypertension. Complications such as hypertension that can occur suddenly are caused by manifestations of a poor patient's lifestyle so that the patient cannot control blood sugar levels properly [16]. In line with previous studies conducted at Ngudi Waluyo Wlingi Regional Hospital said that the survival time of improvement in the clinical condition of patients with hypertension and without hypertension is significantly different [17]. High blood pressure causes the distribution of cells to not run optimally which causes a buildup of sugar and cholesterol in the blood [18].

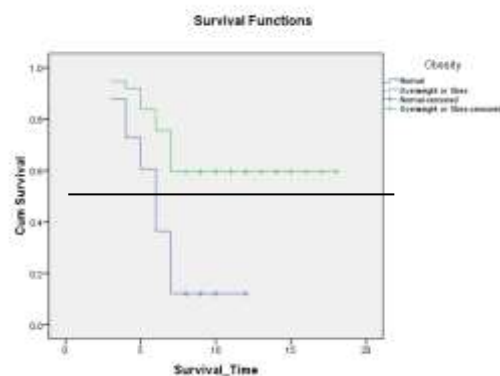

Fig. 3. Kaplan Meier curve of obesity.

Based on the obesity variable, the median survival in patients who have a normal body mass index is 6 days. It can be concluded that 50% of DM patients who have a normal body mass index need 6 days to experience improvement in clinical conditions. However, this is different in people with overweight/obese body mass index that shows 50% of DM patients who have need days exceeding observation time. In the other words, type 2 DM patients who have normal body mass index need faster time to experience improvement in clinical conditions than those who have overweight/obese.

The results of this study are in accordance with the theory which states that more than 8 among sufferers of type 2 DM are those who are overweight. The more fat tissue in the body, the body tissue and muscle will be more resistant to insulin. Too much fat in the body will block the work of insulin so that glucose cannot be flowed into cells and accumulates in the blood circulation [19]. Lipoprotein abnormalities are common in overweight and obese patients with diabetes and contribute significantly to its complications [20]. In the presence of complications, the patient's clinical condition will improve more slowly.

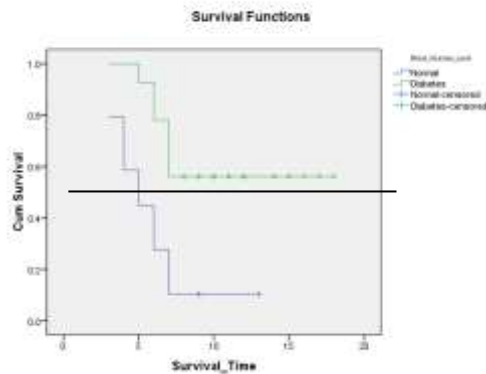

Fig. 4. Kaplan Meier curve of blood glucose level.

In the blood glucose level variable, the median survival in patients who have normal blood glucose levels or <200 mg/dL is 5 days. The conclusion can be taken that 50% of DM patients who have normal blood glucose levels or <200 mg/dL need 5 days to experience improvement in clinical conditions. However, this is different in people with diabetes blood glucose level (≥ 200) that shows 50% of DM patients who have need days exceeding observation time. In the other words, type 2 DM patients who have normal blood glucose level need faster time to experience improvement in clinical conditions than those who have diabetes blood glucose level.

Patients with type 2 DM who are hospitalized experience changes in diet, medications, glucose metabolism, and schedule that can adversely affect blood glucose control. Uncontrolled blood glucose levels in hospitalized patients with diabetes are associated with potential harms such as deleterious effects on wound healing, increased risk of infection, and delays in surgical procedures or discharge from the hospital [21]. The results of previous studies that respondents with blood sugar levels more than average who experienced subjective complaints of 90,9% [22].

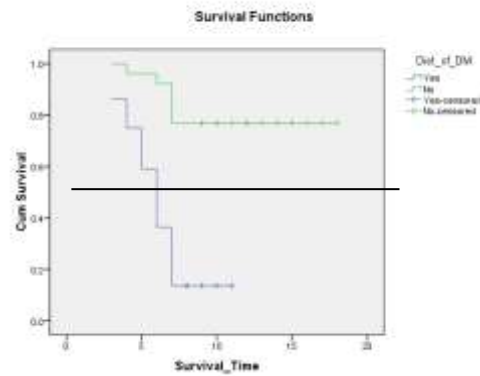

Fig. 5. Kaplan Meier curve of diet of DM.

Based on the diet of DM variables, the median survival in patients on the DM diet is 6 days. It can be concluded that 50% of DM patients who take the diet of DM need 6 days to experience clinical conditions improvement. Nevertheless, this is different in people without Diet of DM that shows 50% of DM patients who have need days exceeding observation time. Otherwise stated, type 2 DM patients who on diet of DM need faster time to experience improvement in clinical conditions than those without diet of DM.

The study that is in line with the results of this study is a survival analysis study in Wahidin Sudirohusodo Makassar Hospital, with the conclusion that patients who are not on a diet have a greater risk of failure compared to those on a diet [23]. The recommendations on dietary aspects can contribute to achieve the desired blood glucose, blood pressure, lipid profile and weight [24].

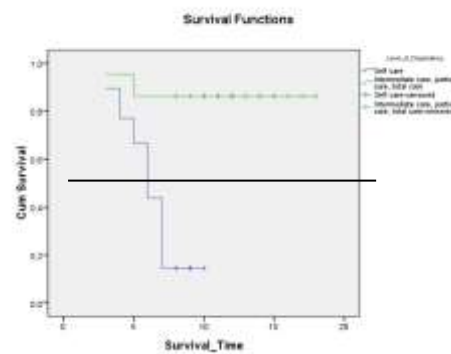

Fig. 6. Kaplan Meier curve of level of dependency.

Based on the level of dependency variable, the median survival in patients who perform self-care is 6 days. It can be concluded that 50% of DM patients who perform self-care require 6 days to experience improvement in clinical conditions. However, this is different in people with intermediate care, partial care, and total care that shows 50% of DM patients who have need days exceeding observation time. In the other

words, type 2 DM patients who perform self-care need faster time to experience improvement in clinical conditions than those who perform intermediate care, partial care, and total care. DM cannot be cured, it can be controlled [25]. DM patients have to learn to live with the disease. Activities that support DM management are self-care. Patients who suffer from DM for more than 5 years will realize the importance of applying self-care after the accompanying symptoms appear, so that not infrequently patients will begin to make the recommended management when signs of complications begin to appear [26].

4 Conclusion

The median survival or 50% of subjects experience clinical condition improvement of age variable (<40 years old was 5 days, ≥ 40 years old was 7 days), hypertension status (normal blood pressure was 6 days), obesity (normal body mass index was 6 days), blood glucose level (normal was 5 days), diet of DM (diet was 6 days), and level of dependency (self-care was 6 days).

Acknowledgments We would like to thank the Faculty of Sports Science, Universitas Negeri Semarang, Indonesia for the funding.

References

- [1] WHO. World Health Statistics. 2018.
- [2] Kemenkes RI. Profil Kesehatan Indonesia 2018. 2018.
- [3] Dinkes Jateng. Profil Kesehatan Jawa Tengah 2018 2019.
- [4] Dinkes Semarang. Profil Kesehatan Kota Semarang 2018 2019.
- [5] Dewi IAPR, Suciptawati NLP, Tastrawati NKT. Aplikasi Regresi Cox Proportional Hazard pada Sintasan Pasien Diabetes Melitus. *E-Jurnal Mat* 2018;7:278.
- [6] Kleinbaum, Klein. *Survival Analysis : A Self Learning Text*. New York: SpringerVerlag; 2005.
- [7] Aristika D. Deskripsi Karakteristik Penderita, Lama Dirawat (LOS) dan Epidemiologi Penyakit Diabetes Mellitus Pada Pasien JKN di RSUD Tugurejo Semarang Triwulan I Tahun 2014 2014.
- [8] Dahlan MS. *Analisis Survival : Dasar-dasar Teori dan Aplikasi dengan Program SPSS*. Epidemiologi Indonesia; 2012.
- [9] Sanusi W. Model Regresi Cox dan Aplikasinya dalam Menganalisis Ketahanan Hidup Pasien Penderita Diabetes Mellitus di Rumah Sakit Bhayangkara Makassar. *J Math Comput Stat* 2018;1:62–77.
- [10] Comino EJ, Harris MF, Islam MDF, Tran DT, Jalaludin B, Jorm L, et al. Impact of diabetes on hospital admission and length of stay among a general population aged 45 year or more: A record linkage study. *BMC Health Serv Res* 2015;15:1–13.
- [11] IDF. Eighth edition 2017. IDF; 2017.
- [12] Sujaya IN. Pola Konsumsi Makanan Tradisional Bali sebagai Faktor Risiko Diabetes Mellitus Tipe 2 di Tabanan. *J Skala Husada* 2009;6:75–81.
- [13] Arif A. Hubungan Faktor Komorbid, Usia dan Status Gizi dengan Lama Rawat Inap pada Pasien Hernia Inguinalis Lateralis Reponibilis yang Dioperasi Herniorepair Tanpa Mesh di RS PKU Muhammadiyah Surakarta Periode 2005 –2007. Surakarta: Universitas Muhammadiyah Surakarta; 2008.

- [14] Engler D, Gilfillan C, Soldatos G, Steele C, Ward GM. The High Burden of Inpatient Diabetes : The Melbourne Public Hospitals Diabetes Inpatient Audit. *MJA* 2014;201:334–8.
- [15] Kim B, Won JC, Lee JH, Kim H, Park JH, Ha KH, et al. Diabetes Fact Sheets in Korea, 2018 : An Appraisal of Current Status. *Diabetes Metab J* 2019;48:7–94.
- [16] Lubis IK. Analisis Length Of Stay (LOS) Berdasarkan Faktor Prediktor Pada Pasien DM Tipe II di RS PKU Muhammadiyah Yogyakarta. *J Kesehat Vokasional* 2017;2:161–6.
- [17] Anggraeni LIA. Perbandingan Analisis Survival Menggunakan Regresi Weibull dan Regresi Cox Proporsional Hazard pada Penderita Diabetes Melitus Tipe II di RSUD Ngudi Waluyo Wlingi Tahun 2013. Institut Teknologi Sepuluh Nopember Surabaya 2015; 2015.
- [18] Alfiah SW. Faktor Risiko yang Berhubungan dengan Kejadian Penyakit Diabetes Melitus pada Pasien Rawat Jalan di Rumah Sakit Umum Pusat Dr.Kariadi Semarang 2011:1–62.
- [19] Tandra H. Segala Sesuatu Yang Harus Anda Ketahui Tentang Diabetes. Jakarta: Gramedia Pustaka Utama; 2008.
- [20] Aljabri KS, Bokhari SA, Akl A. Diabetes and Clinical Research The Relation between Overweight , Obesity and Plasma Lipids in Saudi Adults with Type 2 Diabetes. *Int J Diabetes Clin Res* 2015;2:2–5.
- [21] Kodner C, Anderson L, Pohlgeers K. Glucose Management in Hospitalized Patients. *Am Fam Physician* 2017;96:650–4.
- [22] Lathifah NL. Hubungan Durasi Penyakit dan Kadar Gula Darah dengan Keluhan Subyektif Penderita Diabetes Melitus. *J Berk Epidemiol* 2013;5:231–9.
- [23] Thamrin S. Analisis Data Survival Menggunakan Metode Proportional Hazard dan Accelerated Failure Time. *J Mat Stat Dan Komputasi* 2008;4:97–103.
- [24] Marín-peñalver JJ, Martín-timón I, Cañizo-gómez FJ. Management of Hospitalized Type 2 Diabetes Mellitus Patients. *J Transl Intern Med* 2016;4:155–61.
- [25] Siddiqui MA, Khan MF, Carline TE. Gender Differences in Living with Diabetes Mellitus. *Mat Soc Med* 2013;25:140–2.
- [26] Maxwel A. Diabetes Self Care Knowledge among Type 2 Diabetic Outpatients in South-Eastern Nigeria 2014.

Stunting Risk Factors Based on Priority Region in Indonesia: 2018 National Basic Health Survey

Mahalul Azam¹, Muhamad Zakki Saefurrohim², Syed Mohamed Aljunid³

{mahalul.azam@mail.unnes.ac.id¹, saefurrohim@students.unnes.ac.id²,
saljunid@gmail.com³}

Universitas Negeri Semarang, Semarang, Indonesia^{1,2}
Kuwait University, Kuwait City, Kuwait³

Abstract. Current study aimed to explore the risk factors of stunting based on priority-region status in Indonesia. We extracted national basic health survey in 2018. We defined stunting based on height for age, which Z-score < -2.0, was categorized as stunting. Priority-region categorized by the National Team for Acceleration of Poverty Reduction, Republic of Indonesia, i.e., 100 priority-regions determined. We also observed children's characteristics, i.e., age, sex, birth weight and height, gestational age, weaning age, diarrhea, immunization, breastfeeding, and supplementary feeding. Parent's and household's characteristics were observed as well. Binary regression logistic was performed to conclude risk factors of stunting. We concluded that male children, lower mother's and father's height were the consistent risk factors for priority-, non-priority, and total-regions. Without consider priority-region, we concluded that family members, sex, access to health services, antenatal-care, mother's- and father' s-height, parent's education level, and ferrous-sulfate supplementation altogether were the risk factors for stunting in Indonesia.

Keywords: stunting, risk factors, priority region, Indonesia

1 Introduction

Stunting is a health problem in children that the most burdened in developing countries[1]. Decreasing stunting is one priority of the six goals of *the Global Nutrition Targets* in 2025.[2] Children are determined as stunted if their height for age Z-score were ≤ 2 from the standard deviations [SD][3]. Stunting causes 14.5% of deaths each year. Studies also concluded that there is a link between stunting and cognitive impairment[4][5][6]. Prolonged impairment of cognitive function in children with stunting will affect productivity and economic status[7][8][9]. Other studies have shown that school dropout rates for children with stunting are higher than for normal children[8].

The prevalence of stunting in Indonesia is 30.5%[10], placed comparable to other countries with high stunting burdens[11]. Indeed, the prevalence decreased compared to the previous Indonesia national basic health survey (riset kesehatan dasar:

RISKESDAS) 2013, i.e., 37.2%[12] but must still be concerned. In 2018 the government determined a hundred priority regions, i.e., districts/cities with the highest stunting prevalence. A hundred districts/cities are spread evenly throughout the province, which varies number in each province[13]. This region determination is needed for public health nutrition measures to decrease stunting cases.

Stunting in children developed during the first two years of life (0-23 months). The pivotal causes of stunting are malnutrition[14], non-exclusive breastfeeding[15][16][17], low economic status of the family[18][19][20][21], premature births[21], low birth weight[16][20], low parental education level[18][22][23][24], living in households with 3 or more under 5 years old children[25], households with 5 - 7 family members[25], poor sanitation[20][26], and low access to the health services[20][26][27].

The determinants of stunting are well-established; however, little is known regarding the determinants in the region with a different rate of prevalence, especially in Indonesia. The current study aimed to explore the risk factors of stunting according to priority region in Indonesia based on RISKESDAS 2018. In addition, the current study updated the information regarding stunting in Indonesia from the previous RISKESDAS.

2 Methods

Present study analyzed secondary data obtained from the results of RISKESDAS conducted by the Ministry of Health, the Republic of Indonesia, in 2018. This survey was a nationally representative survey with a cross-sectional study conducted every five years. The population includes households in all provinces and districts/cities, i.e., 34 provinces, 416 districts, and 98 cities in Indonesia. Data collection was done by interview, measurement, and physical examination. Interviews using two instruments, i.e., Household Instruments and Individual Instruments. Details about sampling techniques, survey design, survey instruments, measurement systems, ethical clearance, and quality control have been explained elsewhere[10]. In this analysis, we use information gathered from 27,280 women with children aged 0-23 months who have fulfilled the questionnaire.

2.1 Data management

We defined stunting status data based on obtained RISKESDAS data of children aged 0-23 months. We determined stunting on Z-score with the [SD] calculated from height for age. Stunting determined when Z-score < -2.0. We also analyzed the factors provided based on the latest research related to stunting conducted in Indonesia. [25][28] We identified parameters provided in RISKESDAS data to be analyzed. We concern about the fundamental factors, i.e., priority region as an important parameter for the stunting cases. Priority region selected and determined by the National Team for the Acceleration of Poverty Reduction (Tim Nasional Percepatan Penanggulangan Kemiskinan: TNP2K) in 2018, i.e., 100 priority region[29]. We determined 150 control regions chosen from non-priority regions randomly. We also observed children's characteristics, i.e., age, sex, birth weight, birth height, gesta-

tional age, weaning age, history of diarrhea within two weeks, history of immunization, initiation of early breastfeeding, exclusive breastfeeding, and supplementary feeding. Supplementary feeding determined as adequate supplementation of extra feeding, i.e., biscuits, milk, and other forms administered for the last 12 months.

Regarding parent's characteristics, we observed the educational status of parents, employment status of parents, maternal and paternal stature, maternal age of first birth, desired pregnancy status, administration of ferrous-sulfate tablets, the number of antenatal care (ANC) visits during pregnancy, and the history of pregnancy complication. Pregnancy complications were defined as the presence of gestational related-problems during pregnancy, delivery, and puerperium could be the infection, bleeding, or eclampsia.

We also observed household characteristics, i.e., the number of all family members, the number of children under five years in the household, access to the health services (Public Health Services=Pusat Kesehatan Masyarakat [Puskesmas]), fecal disposal status, and type of drinking water used. Fecal disposal categorized as standardized based on latrine usage, while the type of drinking water categorized as secured when satisfied with the criteria of secured drinking water, i.e., from branded bottled water, governmental drinking water company, and secured water springs.

2.2 Data analysis

Data were presented in frequency and percentage based on case and control status due to categorical data types. *Chi-square* analysis was performed to determine the relationship between determinants and stunting status. P-values <0.05 were considered statistically significant. Factors that have a p-value lower than 0.25 were involved in multivariable analysis. We analyze the final model using *Binary Regression Logistics*. All analyses were performed by SPSS 16.0 (IBM Corporation, NY, USA).

3 Results

Data were extracted from the RISKESDAS 2018, and we got a total of 27,280 children 0-23 months that met the criteria. Of them, 8,537 experienced stunting mean the prevalence based on this subset was 31.29 %. Based on the priority region category, most of them living in the non-priority region, i.e., 21,424 (78.5%), and the rest 21.5 % living in the priority region (Table 1a.)

Table 1a. also shows that the proportion of priority region was significantly higher in the stunting group. The proportion of aged <12 months was significantly lower in the case group compared to the control group. The proportion of males was also remarkable higher in the stunting group. History of diarrhea within the two weeks proportion was significantly higher in the case group, while the history of diarrhea after two weeks was not significantly different between groups. Gestational age < 37 weeks proportion was higher in the stunting group. Birth weight and birth height also demonstrated significant differences between groups. The proportion of lower birth weight was higher in the case group, as well as the proportion of lower birth

height. However, the missing values (not applicable data) of these two parameters were quite high. Weaned age proportion notably different as well, i.e., weaning age of < 12 months tend to be lower in the case group. The other parameters in the children's domain, i.e., supplementary feeding, immunization history, early breastfeeding initiation, and exclusive breastfeeding, were comparable between groups.

Table 1b demonstrated the characteristics in the domain of parents. Mothers and fathers who had lower education levels were higher proportion in the stunting group. There was a significant difference between the mother's employment status proportion, i.e., tend to be lower for stunting group, while the father's employment status was comparable between groups. The mother's age of first labor under 20 years tends to have a higher proportion in the case group.

Table 1. a. Subject Characteristics of children

Characteristics	Stunting status		P-value *	OR [95% CI]
	Yes N = 8,537	No N = 18,743		
Priority region				
Yes n; %	1996; 23.4	3860; 20.6	0.001	1,117 (1,107-1,251)
No n; %	6541; 76.6	14883; 79.4		
Age				
<12 months n; %	3174; 37.2	10533; 56.2	0.001	0.461 (0.438-0.486)
12-23 months n; %	5363; 62.8	8210; 43.8		
Sex				
Male n; %	4730; 55.4	9235; 49.3	0.001	1.279 (1.215-1.347)
Female n; %	3807; 44.6	9508; 50.7		
History of diarrhea				
Yes in <2 weeks n; %	715; 8.4	1324; 7.1	0.001	1.208 (1,099-1,328)
Yes in > 2 weeks n; %	351; 4.1	706; 3.8	0.119	1.112 (0,976-1,268)
Never n; %	7471; 87.5	16713; 89.2	Ref	Ref
Supplementary feeding				
No n; %	4948; 58.0	10985; 58.6	0.320	0.974 (0.974-1.026)
Yes n; %	3589; 42.0	7758; 41.4		
History during birth				
Gestational age				
<37 weeks n; %	2918; 34.2	5996; 32.0	0.001	1.104 (1.046-1.166)
≥ 37 weeks n; %	5619; 65.8	12747; 68.0		
Birth weight				
N/A n; %	3486; 40.8	6961; 37.1		
≤ 2500 g n; %	804; 9.4	1005; 5.4	0.001	2.030 (1.838-2.242)
> 2500 g n; %	4247; 49.7	10777; 57.5		
Birth height				
N/A n; %	4339; 50.8	8736; 46.6		
≤ 44.2 cm n; %	415; 4.9	574; 3.1	0.001	1.803 (1.580-2.057)
> 44.2 cm n; %	3783; 44.3	9433; 50.3		
Immunization history				
N/A n; %	5475; 64.1	12779; 68.2		
No n; %	884; 10.4	1615; 8.6	0.076	1.093 (0.992-1.204)
Yes n; %	2178; 25.5	4349; 23.2		
Early breastfeeding initiation				
No n; %	3844; 45.0	8300; 44.3	0.257	1.031 (0.979-1.085)
Yes n; %	4693; 55.0	10443; 55.7		
Exclusive breastfeeding				
No n; %	3844; 45.0	8300; 44.3	0.257	1.031 (0.979-1.085)
Yes n; %	4693; 55.0	10443; 55.7		
Weaned age				
N/A n; %	215; 2.5	459; 2.4		
<12 months n; %	3978; 46.6	10170; 54.3	0.001	0.731 (0.694-0.770)
≥ 12 months n; %	4344; 50.9	8114; 43.3		

* Chi-Square test

The proportion of pregnant mothers with less than four visits tends to be higher in the stunting category. Lower height, both of the mother and father tend to have a higher proportion in the stunting group. Ferrous-sulfate supplementation group tends

to be lower in the case group, significantly. Pregnancy status and pregnancy complication proportions were comparable between groups.

A household with had three or more under-five years old children significantly had a higher proportion in the case group. (Table 1c.) Similarly, family members five to seven members, as well as eight members or more, tend to be higher in the stunting category. Families with have difficulty accessing public health services tend to have a higher proportion of stunting. Secured drinking water usage tends to have a lower proportion in the stunting cases. Fecal disposal management in the household proportion was comparable between groups.

Table 1. b. Subject Characteristics of parents conditions

Characteristics	Stunting status		P value *	OR [95% CI]
	Yes N = 8,537	No N = 18,743		
Mother's level of education				
High school or lower n; %	7456; 87.3	15851; 84.6	0.001	1.258 (1.167-1.357)
Higher education; %	1081; 12.7	2892; 15.4		
Mother's employment status				
Unemployed n; %	4933; 57.8	11111; 59.3	0.021	0.940 (0.893-0.990)
Employed n; %	3604; 42.2	7632; 40.7		
Mother's age of first labor				
< 20 years n; %	2651; 31.1	5301; 28.3	0.001	1.141 (1.078-1.207)
≥ 30 years n; %	5467; 64.0	12474; 66.6	0.838	1.013 (0.899-1.140)
20 - 29 years n; %	419; 4.9	968; 5.2	Ref	Ref
Pregnancy status				
Undesired n; %	310; 3.6	682; 3.6	1.000	0.998 (0.87-1.144)
Desired n; %	8227; 96.4	18061; 96.4		
Number of ANC visits				
<4 times n; %	2001; 23.4	3856; 20.6	0.001	1.182 (1.112-1.257)
≥ 4 times n; %	6536; 76.6	14887; 79.4		
Mother's height				
<150 cm n; %	3766; 44.1	6133; 32.7	0.001	1.623 (1.540-1.710)
≥ 150 cm n; %	4771; 55.9	12610; 67.3		
Ferrous sulfate supplementation				
No n; %	1275; 14.9	2400; 12.8	0.001	1.196 (1.111-1.287)
Yes n; %	7262; 85.1	16343; 87.2		
Pregnancy complication				
Yes (at least one or more) n; %	987; 11.6	2290; 12.2	0.127	0.939 (0.868-1.017)
No n; %	7550; 88.4	16453; 87.8		
Father's level of education				
High school or lower n; %	7636; 89.4	16249; 86.7	0.001	1.301 (1.200-1.410)
Higher education n; %	901; 10.6	2494; 13.3		
Father's employment status				
Unemployed n; %	203; 2.4	454; 2.4	0.885	0.981 (0.830-1.160)
Employed n; %	8334; 97.6	18289; 97.6		
Father's height				
< 160 cm n; %	2798; 32.8	4618; 24.6	0.001	1.491 (1.410-1.577)
≥ 160 cm n; %	573 9; 67.2	1412 5; 75.4		

ANC: ante-natal care * *Chi-Square test*

Table 1. c. Subject Characteristics regarding household conditions

Characteristics	Stunting status		P-value	OR [95% CI]
	Yes N = 8,537	No N = 18,743		
Number of under-fives in household				
≥ 3 n; %	316; 3.7	513; 2.7	0.001	1.368 (1.185-1.579)
2 n; %	2119; 24.8	4678; 25.0	0.844	1.006 (0.948-1.068)
1 n; %	6102; 71.5	13552; 72.3	Ref	Ref
Members in household				
≥ 8 members n; %	840; 9.8	1719; 9.2	0.020	1.116 (1.018-1.224)
5 - 7 members n; %	4400; 51.5	9495; 50.7	0.041	1.058 (1.002-1.117)
1 - 4 members n; %	3297; 38.6	7529; 40.2	Ref	Ref
Limited access to health services				
Yes n; %	483; 5.7	825; 4.4	0.001	1.302 (1.161-1.462)
No n; %	8054; 94.3	17918; 95.6		
Fecal disposal				
Non latrine usage n; %	51517; 60.4	11517; 61.4	0.105	0.957 (0.908-1.009)
Latrine usage n; %	3380; 39.6	7226; 38.6		
Drinking water				
Unsecured n; %	1536; 18.0	2933; 15.6	0.001	1.183 (1.105-1.266)
Secured n; %	7001; 82.0	15810; 84.4		

under-fives: under five years old children

* Chi-Square test

Table 2. Binary logistic regression of parameters based on priority region

Variable	Non-priority region		Priority region		Total region	
	P	Adjusted OR (95% CI)	P	Adjusted OR (95% CI)	P	Adjusted OR (95% CI)
Priority region					0.001	1.141 (1.072-1.214)
5/more family members	0.024	1.072 (1.009-1.139)			0.018	1.066 (1.011-1.124)
Male	0.001	1.281 (1.207-1.358)	0.001	1.308 (1.172-1.459)	0.001	1.288 (1.223-1.357)
Limited access to health services	0.014	1.191 (1.035-1.369)			0.006	1.180 (1.018-1.163)
ANC visits <4	0.032	1.081 (1.007-1.162)			0.013	1.088 (1.018-1.163)
Mother's height < 150 cm	0.001	1.589 (1.496-1.689)	0.001	1.436 (1.285-1.604)	0.001	1.556 (1.476-1.641)
Father with high school or lower educational level	0.008	1.156 (1.039-1.287)			0.001	1.185 (1.092-1.287)
Father's height < 160cm	0.001	1.138 (1.294-1.479)	0.001	1.444 (1.285-1.622)	0.001	1.400 (1.322-1.482)
No ferrous-sulfate supplementation			0.001	1.419 (1.200-1.678)	0.005	1.200 (1.034-1.213)
Constant	0.001	0.232	0.001	0.542	0.001	0.236

ANC: ante-natal care

Present study also grouping all characteristics based on priority region status as a fundamental determinant of stunting. (Table 2.) We analyzed the characteristics in three groups, i.e., non-priority region, priority region, and total region. Present study

identified seven risk factors in the non-priority group, four risk factors in the priority group, and nine risk factors in the total group. We found that male children, mother's height < 150 cm, father's height < 160 cm were consistent risk factors either in non-priority, priority, or total groups. There were four risk factors associated with stunting in non-priority and total group, i.e., five or more family members, limited access to health services, ANC visits <4, and father with high school or lower education level, while no ferrous-sulfate supplementation was the only risk factors in the priority region and total group. The odds ratio (OR) and confidence interval (CI) for each risk factors presented in Table 2.

4 Discussion

The present study reports the risk factors of stunting in Indonesia. To the best of our knowledge, the present study was the first report of stunting risk factors that differentiated based on priority region status. This study also provided the prevalence of stunting based on the population study, i.e., 31.29%, means consistent with the number in total RISKESDAS 2018 survey, i.e., 30.5%[10]. TNP2K divided region based on stunting problems into priority and non-priority regions. Priority regions consist of 100 districts/cities in Indonesia. These priority regions located in Java and Bali islands, i.e., 40 regions, while 60 regions were outside Java and Bali islands[29]. There were more regions outside Java and Bali islands as priority regions, that related to socioeconomic conditions, especially those in eastern Indonesia. Indeed, development priority in all aspects is concerned in eastern Indonesia; however, appropriate strategies must be improved. Previous studies reported that resources and facilities are limited, especially in the health care services in these regions[25,30].

In this study, in all regions we found consistently, that male children were more likely to get stunting, with also the consistent OR in the non-priority region, priority region, and the total group of 1.28 (95% CI: 1.207-1.358), 1.30 (95% CI: 1.172-1.459), and 1.29 (95% CI: 1.223-1.357), respectively. These results were also consistent with the 2013 RISKESDAS data [25] as well as other studies[31][32][33]. Studies also reported that boys are more susceptible to infectious diseases caused by environmental conditions and their mobilities[34][35]. Mother's height <150 cm and father's height <160 cm in this analysis have a significant relationship. Other studies have found a strong relationship between father's short stature and stunting in children 24-59 months[16]. Current study showed that OR of mother's height less than 150 cm were comparable, i.e. 1.59 (95% CI: 1.496-1.689) 1.44 (95% CI: 1.285-1.604) 1.56 (95% CI: 1.476-1.641), respectively. Regarding father's height < 150cm, the OR in the non-priority region, priority region, and total region were 1.14 (95% CI: 1.294-1.479), 1.44 (95% CI: 1.285-1.622), and 1.40 (95% CI: 1.322-1.482), respectively.

In the priority and total region population, we found that no ferrous-sulfate supplementation were the only risk factors with the OR of 1.42 (1.200-1.678) and 1.20 (1.034-1.213) in priority and total region, respectively. Our findings indicated that administration of ferrous-sulfate tablets is important to support optimal maternal nutrition because this supplementation is needed to ensure optimal intra-uterine fetal growth[36][30] Trials have examined the benefits of iron/folic acid and micronutri-

ents supplementations during pregnancy in promoting fetal growth, birth length and postnatal growth[37][38]. There is a strong relationship between stunting and consumption of animal proteins, especially various types of animal proteins[14][39]. We did not find the relationship between ferrous-sulfate supplementation and stunting in the non-priority region, but lack of additional data founded in the study to conclude the possible cause of this condition.

In the total region from the current study showed that father with high school or lower of education level was related to stunting (OR=1.19 (95% CI: 1.092-1.287), but nor in mother's education level. Previous studies[40] concluded that low education related to stunting. The relationship between parent's education level and stunting is well elucidated but did not differentiate which is the most influenced, whether their father or mother [19][20] In general, the chance of stunting for children is twice higher in the lower level of parental education[40], while this study just showed 1.19 times for lower father's education level.

The family member consists of five or more members was the risk factors as well in the total region with the OR of 1.07 (95% CI: 1.011-1.124). This condition also corresponded with household issues, i.e., the number of under-five years children living in the house. Previous studies[25] concluded; accordingly, this can be due to a location in the availability of food, improper childcare practices, and accessibility of suboptimal family facilities[32][41] Limited access to the health services and ANC visits less than four times were the risk factors for stunting both in non-priority and total regions. These two parameters were related to healthcare services. These findings were the classical problems and still existed to date, as reported previously[40][25]. Poor access to health services and living in remote rural areas were the crucial determinants in the household level [25].

Other studies concluded the other risk factors, i.e., low birth weight and height[7] [24][34], age, and maternal age during pregnancy. Studies reported that children aged <12 months tend to get stunting[15] [24][25], while other studies concluded that aged 12-23 years more likely to get stunting[25][7]. However, we did not find any relationship between the age of children, birth weight/ height, and maternal age during pregnancy to stunting status. Future studies that involved more parameters such as genetic factors and molecular biomarkers should be conducted to elucidate the risk factors of stunting in Indonesia and globally.

5 Conclusion

The present study concluded that there were different risk factors for stunting based on priority region status. Male children, mother's height < 150 cm, and father's height < 160 cm were the constant risk factors for stunting in all region groups. In the total group, we concluded that priority region, five or more family members, male children, limited access to health services, ANC visits < 4, mother's height <150cm, the father with high school or lower educational level, father's height < 160cm, and no ferrous-sulfate supplementation altogether were the risk factors for stunting in Indonesia.

Acknowledgments

We thank the Faculty of Sports Science, Universitas Negeri Semarang, for the Research Grant. We also thank the National Institute of Health Research and Development, Ministry of Health, the Republic of Indonesia, for providing RISKESDAS 2018 data.

References

- [1] Oh SH, Ahn DC, Kim YS. A study on the mechanical properties and springback of 3D aluminum sheets. *Int J Precis Eng Manuf* 2016;17:671–7.
- [2] World Health Organization. Global targets 2025 to improve maternal, infant and young children nutrition. 2017.
- [3] Stirnemann J, Villar J, Salomon LJ, Ohuma E, Ruyan P, Altman DG, et al. International estimated fetal weight standards of the INTERGROWTH-21st Project. *Ultrasound Obstet Gynecol* 2017;49:478–86.
- [4] Watanabe K, Flores R, Fujiwara J, Tran LTH. Early Childhood Development Interventions and Cognitive Development of Young Children in Rural Vietnam. *J Nutr* 2005;135:1918–25.
- [5] Kar BR, Rao SL, Chandramouli BA. Cognitive development in children with chronic protein energy malnutrition. *Behav Brain Funct* 2008;4:1–12.
- [6] Sokolovic N, Selvam S, Srinivasan K, Thankachan P, Kurpad A V., Thomas T. Catch-up growth does not associate with cognitive development in Indian school-age children. *Eur J Clin Nutr* 2014;68:14–8.
- [7] Prendergast AJ, Humphrey JH. The stunting syndrome in developing countries. *Paediatr Int Child Health* 2014;34:250–65.
- [8] Perignon M, Fiorentino M, Kuong K, Burja K, Parker M, Sisokhom S, et al. Stunting, poor iron status and parasite infection are significant risk factors for lower cognitive performance in Cambodian school-aged children. *PLoS One* 2014;9.
- [9] Victora CG, Adair L, Fall C, Hallal PC, Martorell R, Richter L, et al. Maternal and child undernutrition: consequences for adult health and human capital. *Lancet* 2008;371:340–57.
- [10] Badan Penelitian dan Pengembangan Kesehatan. Laporan Nasional Riset Kesehatan Dasar: RISKESDAS (Indonesia Basic Health Survey) tahun 2018. 2019.
- [11] WHO. Nutrition Landscape Information System (NLIS). *Nutr Landcape Inf Syst* 2018;1–51.
- [12] Badan Penelitian dan Pengembangan Kesehatan. *Risikesdas Biomedis Riset Kesehatan Dasar* 2013. Jakarta: 2013.
- [13] Tim Nasional Percepatan Penanggulangan Kemiskinan: TNP2K (National Team for the Acceleration of Poverty Reduction). *Strategi Nasional Percepatan Pencegahan Stunting 2018-2024 (National Strategy for Accelerating Stunting Prevention 2018-2024)*. 2018.
- [14] Gibson RS, Manger MS, Krittaphol W, Pongcharoen T, Gowachirapant S, Bailey KB, et al. Does zinc deficiency play a role in stunting among primary school children in NE Thailand? *Br J Nutr* 2007;97:167–75.
- [15] Torlesse H, Cronin AA, Sebayang SK, Nandy R. Determinants of stunting in Indonesian children: Evidence from a cross-sectional survey indicate a prominent role for the water, sanitation and hygiene sector in stunting reduction. *BMC Public Health* 2016;16:1–11.
- [16] Rachmi CN, Agho KE, Li M, Baur LA. Stunting coexisting with overweight in 2·0-4·9-year-old Indonesian children: Prevalence, trends and associated risk factors from repeated cross-sectional surveys. *Public Health Nutr* 2016;19:2698–707.

- [17] Ramli, Agho KE, Inder KJ, Bowe SJ, Jacobs J, Dibley MJ. Prevalence and risk factors for stunting and severe stunting among under-fives in North Maluku province of Indonesia. *BMC Pediatr* 2009;9:64.
- [18] Fernald LCH, Kariger P, Hidrobo M, Gertler PJ. Socioeconomic gradients in child development in very young children: Evidence from India, Indonesia, Peru, and Senegal. *Proc Natl Acad Sci U S A* 2012;109:17273–80.
- [19] Sari M, de Pee S, Bloem MW, Sun K, Thorne-Lyman AL, Moench-Pfanner R, et al. Higher Household Expenditure on Animal-Source and Nongrain Foods Lowers the Risk of Stunting among Children 0–59 Months Old in Indonesia: Implications of Rising Food Prices. *J Nutr* 2010;140:195S–200S.
- [20] Semba RD, Moench-Pfanner R, Sun K, De Pee S, Akhter N, Rah JH, et al. Consumption of micronutrient-fortified milk and noodles is associated with lower risk of stunting in preschool-aged children in Indonesia. *Food Nutr Bull* 2011;32:347–53.
- [21] Prawirohartono E, Nurdianti D, Hakimi M. Prognostic factors at birth for stunting at 24 months of age in rural Indonesia. *Paediatr Indones* 2016;56:48.
- [22] Berger SG, de Pee S, Bloem MW, Halati S, Semba RD. Malnutrition and Morbidity Are Higher in Children Who Are Missed by Periodic Vitamin A Capsule Distribution for Child Survival in Rural Indonesia. *J Nutr* 2007;137:1328–33.
- [23] Oddo VM, Rah JH, Semba RD, Sun K, Akhter N, Sari M, et al. Predictors of maternal and child double burden of malnutrition in rural Indonesia and Bangladesh. *Am J Clin Nutr* 2012;95:951–8.
- [24] Schmidt MK, Muslimatun S, West CE, Schultink W, Gross R, Hautvast JGAJ. Nutritional Status and Linear Growth of Indonesian Infants in West Java Are Determined More by Prenatal Environment than by Postnatal Factors. *J Nutr* 2002;132:2202–7.
- [25] Titalay CR, Ariawan I, Hapsari D, Muasyaroh A, Dibley MJ. Determinants of the stunting of children under two years old in Indonesia: A multilevel analysis of the 2013 Indonesia basic health survey. *Nutrients* 2019;11.
- [26] Bardosono S, Sastroamidjojo S, Lukito W. Determinants of child malnutrition during the 1999 economic crisis in selected poor areas of Indonesia. *Asia Pac J Clin Nutr* 2007;16:512–26.
- [27] Anwar F, Khomsan A, Sukandar D, Riyadi H, Mudjajanto ES. High participation in the Posyandu nutrition program improved children nutritional status. *Nutr Res Pract* 2010;4:208.
- [28] Akram R, Sultana M, Ali N, Sheikh N, Sarker AR. Prevalence and Determinants of Stunting Among Preschool Children and Its Urban–Rural Disparities in Bangladesh. *Food Nutr Bull* 2018;39:521–35.
- [29] Tim Nasional Percepatan Penanggulangan Kemiskinan: TNP2K (National Team for the Acceleration of Poverty Reduction). 100 kabupaten/Kota Prioritas untuk intervensi anak kerdil (stunting). 2017.
- [30] Bhutta ZA, Das JK, Rizvi A, Gaffey MF, Walker N, Horton S, et al. Evidence-based interventions for improvement of maternal and child nutrition: What can be done and at what cost? *Lancet* 2013;382:452–77.
- [31] Mostafa Kamal SM. Socio-economic determinants of severe and moderate stunting among under-five children of rural Bangladesh. *Malays J Nutr* 2011;17:105–18.
- [32] García Cruz LM, González Azpeitia G, Reyes Suárez D, Santana Rodríguez A, Loro Ferrer JF, Serra-Majem L. Factors associated with stunting among children aged 0 to 59 months from the central region of Mozambique. *Nutrients* 2017;9:1–16.
- [33] Aryastami NK, Shankar A, Kusumawardani N, Besral B, Jahari AB, Achadi E. Low birth weight was the most dominant predictor associated with stunting among children aged 12–23 months in Indonesia. *BMC Nutr* 2017;3:1–6.
- [34] Hansen Pupp I, Hellström-Westas L, Elsmén E. Preterm male infants need more initial respiratory and circulatory support than female infants. *Acta Paediatr Int J Paediatr*

- 2004;93:529–33.
- [35] Wamani H, Åström AN, Peterson S, Tumwine JK, Tylleskär T. Boys are more stunted than girls in Sub-Saharan Africa: A meta-analysis of 16 demographic and health surveys. *BMC Pediatr* 2007;7:1–10.
 - [36] Leroy JL, Ruel M, Habicht JP. Critical windows for nutritional interventions against stunting. *Am J Clin Nutr* 2013;98:854–5.
 - [37] Ramakrishnan U, Grant FK, Goldenberg T, Bui V, Imdad A, Bhutta ZA. Effect of multiple micronutrient supplementation on pregnancy and infant outcomes: A systematic review. *Paediatr Perinat Epidemiol* 2012;26:153–67.
 - [38] Roberfroid D, Huybregts L, Lanou H, Ouedraogo L, Henry MC, Meda N, et al. Impact of prenatal multiple micronutrients on survival and growth during infancy: A randomized controlled trial. *Am J Clin Nutr* 2012;95:916–24.
 - [39] Kahssay M, Woldu E, Gebre A, Reddy S. Determinants of stunting among children aged 6 to 59 months in pastoral community, Afar region, North East Ethiopia: unmatched case control study. *BMC Nutr* 2020;6:1–8.
 - [40] Beal T, Tumilowicz A, Sutrisna A, Izwardy D, Neufeld LM. A review of child stunting determinants in Indonesia. *Matern Child Nutr* 2018;14:1–10.
 - [41] Leal VS, de Lira PIC, de Menezes RCE, Oliveiral JS, Sequeira LA de S, de Andrade SLLS, et al. Factors associated with the decline in stunting among children and adolescents in Pernambuco, northeastern Brazil. *Rev Saude Publica* 2012;46:234–41.

People's Clean and Healthy Behaviors during the COVID-19 Outbreak: A Case Study in DKI Jakarta Province

Marlinda Budiningsih¹, Nofi Marlina Siregar², Masnur Ali³
{mbudiningsih@unj.ac.id¹, nofims@unj.ac.id², ali.masnur@unj.ac.id³}

Universitas Negeri Jakarta, Jakarta, Indonesia¹²³

Abstract. Since the coronavirus novel case was first announced by the Government of the Republic of Indonesia, we conducted research that aims to find out the impact of the novel coronavirus towards people's clean and healthy behaviors in DKI Jakarta Province. Random sampling was used in this study with samples (n=349) who filled in online questions via Google Form. To date (1st June 2020), there is no vaccine or no specific treatment for COVID-19. Therefore, efforts to prevent transmission of SARS-CoV-2 can be done by applying a clean and healthy life culture. This research show the culture is reflected in the behavior of washing hands, consuming nutritious food, exercising regularly and getting enough rest, not smoking and avoiding cigarette smoke, as well as maintaining environmental hygiene and personal hygiene has been carried out by the community of the Province of DKI Jakarta. Preparedness should be a priority for future pandemic outbreak.

Keywords: DKI Jakarta Province, SARS-CoV-2, COVID-19, Clean and Healthy Life Behavior

1 Introduction

In 2020 a significant threat to public health emerged [1]. The outbreak was officially reported to occur in the late 2019, on 31 December 2019, a case of pneumonia with clinical symptoms of patients such as dry cough, dyspnea and fever whose unknown etiology was identified in Wuhan City, Hubei Province in China [2, 3]. Chinese scientist reported that the virus had 96,3% genetic similarity with a Yunnan bat coronavirus RaTG13 and 70% homology with severe acute respiratory syndrome coronavirus (SARS-CoV), cause this epidemic outbreak was discovered in 2019 then World Health Organization named the disease as COVID-19 short for "coronavirus disease 2019" [4, 5]. COVID-19 was initially identified to spread through animals because the identified patients' history have links to Wuhan's Huanan Seafood Wholesale Market that sells fish and various live animals such as poultry, bats, guinea pigs and snakes [6]. However, further investigations revealed that some people who contracted the infection had no track record of visiting the market, indicating that the spread of the virus from human to human was possible [7]. The spread occurs due to close contact with an infected person by spreading through respiratory secretions,

such as how influenza (flu) spreads, people with COVID-19 have symptoms of fever, coughing, muscle aches, headaches and diarrhea, so initially it will be difficult to distinguish disease COVID-19 with other viral infections such as flu [8].

The World Health Organization (WHO) has confirmed a total of 2,954,222 infected cases with 202,597 deaths during the coronavirus outbreak occurred throughout the world [9]. Indonesia reported 2 positive cases of COVID-19 for the first time on March 2, 2020 [10]. To date (29th April 2020) there were 9,511 positive cases, 7,484 patients were in treatment, 1,254 patients had recovered, and 773 cases had died due to the virus, the emergence and spread of COVID-19 occurred to almost all of the world is a global pandemic threat [11,12]. Up to the date this article was written, DKI Jakarta Province is the highest area in Indonesia with confirmed COVID-19 cases reaching up to 4,033 positive cases, 2,002 patients in treatment, 412 patients recovered, 381 cases died due to viruses and 1,238 independently isolated patients [13]. The first case of COVID-19 in Indonesia occurred in DKI Jakarta Province, the patient was suspected of being infected by a foreign citizen, who was identified positively after being examined abroad. After that, imported cases from people returning from traveling abroad started to be discovered [14].

In an effort to reduce the spread of COVID-19, the DKI Jakarta Provincial Government issued an initial press release in taking fast and responsive steps, they officially adopted Large-scale social restrictions that were applied for 14 days on April 10, 2020 [15,16]. In addition to large-scale restrictions, WHO also recommends maintaining environmental hygiene and personal health such as the availability of clean water, waste management and sanitation, maintaining environmental hygiene and ensuring regular hand washing that can help prevent, slow down and stop the spread of COVID-19 outbreaks from humans to humans [17,18].

During the pandemic period in DKI Jakarta Province, research on clean and healthy behavior in the community during the COVID-19 outbreak was very limited. This study aims to find out the culture of clean and healthy behavior carried out by the people of DKI Jakarta province during the pandemic, which is expected to reduce the spread of COVID-19. Clean and healthy life behavior suggested by the government of the Republic of Indonesia and WHO is one of the important indicators to reduce the spread of the virus. Therefore, people of DKI Jakarta Province as the epicenter with the highest spread of COVID-19 in Indonesia, are obliged to comply with health protocols by taking care of their own health, one of them through cultural activities of clean and healthy living.

This study only covered less than ten percent of the total population of DKI Jakarta Province. Therefore, through the results of this study, it is hoped that the Provincial Government of DKI Jakarta will be able to increase public awareness to keep conducting clean and healthy behavioral activities as part of COVID-19 prevention efforts.

2 Method

We collected data information from samples ($n = 349$) who are domiciled in DKI Jakarta Province using random sampling techniques. Electronic surveys in the form of Google forms, data collection was carried out by distributing electronic ques-

tionnaires through social media networks from 19 to 27 April 2020 in DKI Jakarta in general. The sample size was determined by using the Issac and Michael tables for an error rate of 5% [19], obtained a minimum number of 349 samples from 10,557,810 populations of DKI Jakarta Province [20]. Respondents were asked about knowledge of the COVID-19 outbreak, symptom screening, prevention protocols, and clean and healthy living behaviors during the COVID-19 outbreak such as washing hands, consumption of balanced nutritious food, regular exercise and adequate rest, avoidance of smoking and inhaling cigarette smoke, and also maintaining environmental cleanliness.

Responses are shown on a 5-point scale Likert-type with anchor rank (1 = strongly disagree, 2 = disagree, 3 = doubtful, 4 = agree, 5 = strongly agree), the statements are dichotomized to be high (4-5) and low (1-3). Respondents completed demographic items including gender, age, education, and occupation. All data were processed using IBM SPSS Windows 26 version statistics. Fifteen percent of the processed data was checked for validity and no errors were found. Descriptive statistics are reported to find out the relationship between the COVID-19 issue and the clean and healthy behavior of the people of DKI Jakarta Province during the COVID-19 outbreak.

3 Result

Data collected from the electronic survey form totaled to 349 respondents, with respondent demographics were as follows: 62.5% male respondents and 37.5% female respondents. The average age of respondents is 24 years with a standard error of 0.430. Based on the characteristics of the respondents' education level of 82.8% respondents had graduated from high school/vocational school/MA and 13.2% of respondents had graduated from D4/S1. Characteristics of the respondents' work type are 75.4% as students and 8.3% as private employees.

Based on the results of research data processing, it is known that 87.0% of respondents know information regarding new viruses that are endemic in DKI Jakarta Province, 89.0% of respondents know the symptoms caused by viruses so that they can do early screening if contracted by the virus, 75.0% of respondents know how to prevent so as to avoid contracting the virus. The results related to clean and healthy life behavior during the COVID-19 pandemic period are stated in five indicators namely as many as 89.0% of respondents did hand washing more frequently than usual during the COVID-19 outbreak, 86.3% of respondents consumed nutritious food and health supplements with the aim to maintain immunity during the COVID-19 outbreak, 78.2% of respondents do regular exercise and adequate rest to avoid the virus, 83.9% of respondents do not smoke and avoid cigarette smoke, and 80.0% of respondents always maintain personal hygiene and the environment. Based on these results it can be concluded that there is a significant influence (p -value = .000) between the COVID-19 issue and the clean and healthy behavior of the community during the COVID-19 outbreak.

Characteristics and knowledge of respondents about COVID-19 as well as a clean and healthy living behavior is shown in Table 1.

Table 1. People's Clean and Healthy Behaviors During the COVID-19 Outbreak (n=349)

Characteristics	Entire	Female	Male
	%	%	%
Total		37.5	62.5
Information of Covid-19 Outbreak			
High (4-5)	87.0	85.7	88.4
Low (1-3)	13.0	14.3	11.6
Symptom Screening			
High(4-5)	89.0	88.3	89.7
Low (1-3)	11.0	11.7	10.3
Prevention of Contracting			
High (4-5)	75.0	75.1	74.8
Low (1-3)	25.0	24.9	25.2
Hand Washing			
High (4-5)	89.0	86.6	91.3
Low (1-3)	11.0	13.4	8.7
Consumption of Nutritious Foods			
High (4-5)	86.3	82.1	90.5
Low (1-3)	13.7	17.9	9.5
Regular Exercise and Adequate Rest			
High (4-5)	78.2	76.5	79.9
Low (1-3)	21.8	23.5	20.1
Do not Smoke and Avoid Cigarette Smoke			
High (4-5)	83.9	79.2	88.5
Low (1-3)	16.1	20.8	11.5
Maintaining Environmental Cleanliness			
High (4-5)	80.0	81.1	78.9
Low (1-3)	20.0	18.9	21.1

4 Discussion

Based on the age characteristics of the respondent, the age range of 14-29 years old is the age of 15% of positive cases in Indonesia, while the largest percentage of positive cases (54%) are in the age group of 30-59 years [21]. The high percentage of positive cases in Indonesia makes 87.0% of respondents in need of information about the COVID-19 outbreak. Information literacy is needed in accessing, utilizing and disseminating various information related to COVID-19, originating from reliable sources from both the Central Government and Regional Governments so that through accurate information on an issue can make individuals become disciplined in dealing with that particular issue. [22, 23]. The information in question is the accessibility of one of the pages owned by the Provincial Government of DKI Jakarta, namely <https://corona.jakarta.go.id>. On this page there is information about screening for early symptoms of the COVID-19 virus that aims to identify diseases that have not been recognized by humans by applying tests or examination that can be applied quickly using the method of questions about the cause of the disease or medical and journey history [24,25]. By using this page, 89.0% of respondents were able to screen for the initial symptoms of COVID-19.

Based on the appeal from the World Health Organization, we can prevent transmission of the virus by taking several actions such as 1) cleaning hands with antiseptic as well as soap and running water; 2) do the protocol to keep a distance of at least 1 (one) meter from the others; 3) avoid activities in the crowds; 4) avoid touching eyes, nose and mouth; 4) make sure we and the people around us keep our nose and mouth hygiene; 5) stay home when potentially suffering from cough, headache, itchy throat until it feels healed [26,27]. The appeal for prevention is carried out because of the limited knowledge of the newly discovered viruses and as a key of prevention by doing individual basic protection [28]. Efforts to increase knowledge, screening for symptoms and acting in prevention are related to what is referred to as healthy behavior, namely efforts to improve and maintain health and attitudes in responding to health actions such as individual evaluations of matters relating to health and direct actions to obtain a healthy life [29].

Washing hands is one indicator of clean and healthy living behavior as fingers can be a pathway for pathogens, bacteria and viruses [30], washing hands with soap has been proven to reduce diarrheal diseases and acute respiratory infections [31]. Apart from soap, *hand sanitizers* can be used in avoiding COVID-19 transmission [27]. Therefore, 89.0% of respondents have taken precautions to prevent transmission of the COVID-19 virus by washing their hands at certain times.

Cases of death at Renmin Hospital of Wuhan University show that age and congenital illnesses of patients such as hypertension, diabetes, heart disease, kidney disease, stroke, COPD, tumors, and acute pancreatic disease are risk factors causing death [32]. Therefore, endurance and good body condition are needed to prevent transmission of COVID-19. Someone with a good diet will have a better immune system compared to people with a poor diet, the principle of a healthy diet are safe, nutritious, diversified and balanced [33]. Adequacy of nutrition, especially vitamins and minerals is needed in maintaining an optimal immune system as a preventive effort to always be healthy [34].

Strong endurance is one factor that can avoid the COVID-19 virus, regular exercise with a frequency of 3-5 times per week that is done with moderate intensity and duration not too long around 30-45 minutes can be a way to maintain health, fitness and endurance [35]. A good exercise is when the heart rate works between 60-80% of the maximum heart rate with a length of exercise between 30 to 60 minutes, excessive regular exercise will make the body become tired that it can cause pain [36]. Enough rest is also a factor that can maintain a healthy body, because adequate rest will help avoid various diseases such as heart disease, high blood pressure, stroke and even diabetes [37].

Smoking habit can reduce life span by half, because smoking can cause: 1) hair loss; 2) cataracts; 3) early hearing loss; 4) chronic lung damage; 5) damage teeth and bad breath; 6) stroke and heart attack; 7) make bones break more easily; 8) skin cancer and; 9) impotence disorders and pregnancy and even uterine cancer [38,39]. In addition to active smokers, passive smokers can also suffer from various diseases, based on WHO's call that there are diseases caused by cigarette smoke such as: 1) lung cancer; 2) asthma; 3) chronic obstructive pulmonary disease; 4) tuberculosis; 5) other respiratory diseases and decreased lung function [40]. There are no studies linking the risk of SARS-CoV-2 infection with smoking. However, tobacco smokers are more susceptible

to COVID-19 due to finger contact (contaminated cigarettes) with the lips which increases the likelihood of hand-to-mouth transmission of the virus [41].

Maintaining environmental cleanliness during the outbreak of COVID-19 can help prevent the spread of the virus as cleaning dirty surfaces using cleaning soap and water so as to reduce germs, dirt and stains, while cleaning the surface with disinfectant (recommended that meets the EPA standard criteria) is able to kill germs and viruses [17,42]. In addition to cleaning the surface of objects in the home environment, Hong Kong's Center for Health Protection advises people to maintain drainage pipes on a regular basis by pouring water into the drain and putting toilet covers before rinsing with the aim of avoiding the spread of germs [43]. Tissue or other materials used when sneezing and coughing must be thrown into the trash as soon as possible or put in trash that is tightly bound in a black bag before being disposed of and taken by environmental cleaners, then hand hygiene must be maintained after carrying out the waste disposal activity [17].

5 Conclusion

This research proves that the activities of washing hands, consuming nutritious food, exercising regularly and resting adequately, not smoking and avoiding cigarette smoke and maintaining environmental hygiene have been carried out by the people of DKI Jakarta Province. The clean and healthy life culture carried out by the people of DKI Jakarta Province is one of the efforts to prevent the spread of COVID-19, even though the data compiled from the DKI Jakarta Provincial Government website related to the number of positive sufferers of COVID-19 did not experience a significant decrease. Through this research it can be seen that the issue of COVID-19 can influence clean and healthy life behavior in the community.

The clean and healthy living behavior like washing hands, consuming nutritious food, exercising regularly and getting enough rest, not smoking and avoiding cigarette smoke, and maintaining environmental cleanliness and personal hygiene are among the preventive actions that are easily carried out by each individual.

The subject of this study only targets less than 10 percent of the population in DKI Jakarta Province. Therefore, greater efforts are needed that focus on prevention rather than treatment by conducting health promotion aimed at changing public perceptions about maintaining hygiene and health as a way to prevent infectious diseases [44].

References

- [1] Elengoe A. COVID-19 Outbreak in Malaysia. *Osong Public Heal Res Perspect* 2020;11:93–100.
- [2] Lee A. Wuhan novel coronavirus (COVID-19): why global control is challenging? *Public Health* 2020;179:A1–2.
- [3] Sohrabi C, Alsafi Z, O'Neill N, Khan M, Kerwan A, Al-Jabir A, et al. World Health Organization declares global emergency: A review of the 2019 novel coronavirus (COVID-19). *Int J Surg* 2020;76:71–6. <https://doi.org/10.1016/j.ijsu.2020.02.034>.
- [4] Singhal T. A Review of Coronavirus Disease-2019 (COVID-19). *Indian J Pediatr* 2020;87:281–6.

- [5] WHO. Cronavirus disease (COVID-19) Situation Report-22. WHO Bull 2020.
- [6] Lu H, Stratton CW, Tang YW. Outbreak of pneumonia of unknown etiology in Wuhan, China: The mystery and the miracle. *J Med Virol* 2020;92:401–2.
- [7] Shereen MA, Khan S, Kazmi A, Bashir N, Siddique R. COVID-19 infection: Origin, transmission, and characteristics of human coronaviruses. *J Adv Res* 2020;24:91–8.
- [8] Thompson LA, Rasmussen SA. What Does the Coronavirus Disease 2019 (COVID-19) Mean for Families? *JAMA Pediatr* 2020;2019:2020.
- [9] Tomar A, Gupta N. Prediction for the spread of COVID-19 in India and effectiveness of preventive measures. *Sci Total Environ* 2020;728:138762.
- [10] Tosepu R, Gunawan J, Effendy DS, Ahmad LOAI, Lestari H, Bahar H, et al. Correlation between weather and Covid-19 pandemic in Jakarta, Indonesia. *Sci Total Environ* 2020;725.
- [11] Chakraborty I, Maity P. COVID-19 outbreak: Migration, effects on society, global environment and prevention. *Sci Total Environ* 2020;728:138882.
- [12] Kemenkes RI. Peta Sebaran COVID-19 2020.
- [13] Diskominfotik PDJ. Data Pemantauan COVID-19 DKI Jakarta 2020.
- [14] Vermonte P. Karakteristik dan Persebaran COVID-19 di Indonesia: Temuan Awal. Jakarta: 2020.
- [15] Diskominfotik PDJ. Siaran Pers Nomor 1090/SP-HMS/03/2020. DKI Jakarta: 2020.
- [16] Diskominfotik PDJ. Siaran Pers No 1191/SP-HMPS/04/2020. DKI Jakarta: 2020.
- [17] WHO. Water, sanitation, hygiene and waste management for the COVID-19 virus. 2020.
- [18] WHO. Critical preparedness, readiness and response actions for COVID-19. 2020.
- [19] Sugiyono. Metode Penelitian Kuantitatif, Kualitatif, dan R&D. 23rd ed. Bandung: Alfabeta; 2016.
- [20] Airlangga B. Provinsi DKI Jakarta Dalam Angka 2020 2020.
- [21] Idhom AM. Update Corona Indonesia 30 April 2020 & Data Covid-19 Dunia Terkini 2020.
- [22] Ngafifi M. Kemajuan Teknologi Dan Pola Hidup Manusia Dalam Perspektif Sosial Budaya. *J Pembang Pendidik Fondasi Dan Apl* 2014;2:33–47.
- [23] Subarjo AH. Perkembangan Teknologi dan Pentingnya Literasi Informasi untuk Mendukung Ketahanan Nasional. *J Ilm Bid Teknol ANGKASA* 2017;IX:1–8.
- [24] Dinkes DJ. Informasi COVID-19 Dinas Kesehatan DKI Jakarta 2020.
- [25] Maulani J. Aplikasi Kesehatan Menggunakan Metode Epidemiologi Skrining Tes Untuk Karyawan Cv.Annisa. *Technol J Ilm* 2019;10:10–6.
- [26] Susilo A, Rumende CM, Pitoyo CW, Santoso WD, Yulianti M, Sinto R, et al. Coronavirus Disease 2019: Tinjauan Literatur Terkini Coronavirus Disease 2019: Review of Current Literatures. *J Penyakit Dalam Indones* 2020;7:45–67.
- [27] WHO. Coronavirus disease (COVID-19) advice for the public 2020.
- [28] Kemenkes. Pedoman kesiapan menghadapi COVID-19. Maret 2020. Jakarta: Direktorat Jenderal Pencegahan dan Pengendalian Penyakit (P2P); 2020.
- [29] Putri Lina H. Perilaku Hidup Bersih dan Sehat (PHBS) Siswa Di SDN 42 Korog Gadang Kecamatan Kuranji Padang 2016;4:92–103.
- [30] Octa A, Widi A. Hubungan Pengetahuan dan Sikap terhadap Perilaku Cuci Tangan pada Masyarakat Kelurahan Pegirian 2019;7:1–11.
- [31] Freeman MC, Stocks ME, Cumming O, Jeandron A, Higgins JPT, Wolf J, et al. Systematic review: Hygiene and health: Systematic review of handwashing practices worldwide and update of health effects. *Trop Med Int Heal* 2014;19:906–16.
- [32] Li X, Wang L, Yan S, Yang F, Xiang L, Zhu J, et al. Clinical characteristics of 25 death cases with COVID-19: A retrospective review of medical records in a single medical center, Wuhan, China. *Int J Infect Dis* 2020;94:128–32.
- [33] Muhammad DRA. Pola Makan Sehat dan Bergizi untuk Meningkatkan Imunitas saat Terserang Covid-19. UNS 2020.

- [34] Siswanto S, . B, Ernawati F. Peran Beberapa Zat Gizi Mikro Dalam Sistem Imunitas. *Gizi Indones* 2013;36:57–64.
- [35] Sofro ZM. Pakar UGM Bagi Tips Olahraga di Tengah Pandemi Covid-19. *UGM* 2020.
- [36] Suharjana S. Kebiasaan Berperilaku Hidup Sehat Dan Nilai-Nilai Pendidikan Karakter 2012:189–201.
- [37] Omeoo. Memetik Manfaat Tidur. *P2ptm Kemkes RI* 2016.
- [38] Utari DT. Hubungan Antara Pengetahuan Remaja Tentang Perilaku Hidup Bersih dan Sehat (PHBS) di Sekolah dengan Kebiasaan Merokok di SMP Negeri 7 Samarinda. *Universitas Muhammadiyah Kalimantan Timur*, 2018.
- [39] Wijaya AM. Data dan Situasi Rokok (Cigarette) Indonesia Terbaru. 15 Mei 2013.
- [40] WHO. Tubuh tembakau. 2019.
- [41] WHO. WHO statement: Tobacco use and COVID-19. 2020.
- [42] National Center for Immunization and Respiratory Diseases D of VD. *Cleaning And Disinfecting Your Home*. 2020.
- [43] Regan H. How can the coronavirus spread through bathroom pipes? Experts are investigating in Hong Kong. *CNN* 2020.
- [44] Bloomfield SF, Rook GAW, Scott EA, Shanahan F, Stanwell-Smith R, Turner P. Time to abandon the hygiene hypothesis: New perspectives on allergic disease, the human microbiome, infectious disease prevention and the role of targeted hygiene. *Perspect Public Health* 2016;136:213–24.

Development of Health Information System in TB Control Decision Support: Territoriality-Based Approach

Maryani Setyowati¹, Noor Alis Setiyadi², Suharyo³, Dwi Feri Febiyanto⁴,
Slamet Sudaryanto⁵
{ maryani.setyowati@dsn.dinus.ac.id¹, noor.setiyadi@ums.ac.id²,
suharyo@dsn.dinus.ac.id³ }

Universitas Dian Nuswantoro, Semarang, Indonesia^{1,3}
Universitas Muhammadiyah Surakarta, Surakarta, Indonesia²

Abstract. The Case Notification Rate of Tuberculosis (TB) in Sukoharjo regency in 2018 was the lowest. Various efforts have been undertaken, but the results have not yet reached the target. The research purpose was to develop a TB decision support system to assist in the TB suspects screening program in the Sukoharjo Regency. The method was a system development with System Development Life Cycle approach in Sukoharjo Regency. Research subjects were case subjects and system user subjects. The data was obtained by observation and interview. The results, the web-based and android systems tools were developed by management levels, from the village level, sub-district level, and the District Health Office Sukoharjo and tested at the district, community health center, and village levels. The TB Program's decision support system, it was easier for the parties concerned to see the distribution of TB sufferers in their working area and easy to determine further policies.

Keywords: Tuberculosis, Decision Support System, Suspect tracking, mapping

1 Introduction

Tuberculosis (TB) is still a global disease. Based on Sustainable Development Goals, 2030, its goal is to the reduction in tuberculosis deaths by 90% and decreasing incidence by 80% in 2030 compared to 2014. In 2015 there were an estimated 10, 4 million new cases of tuberculosis, or there are 142 cases per 100,000 population with as many as 480,000 cases of multidrug-resistant or MDR. Indonesia became the country with the second-largest number of cases in the world after India because 60% of new tuberculosis cases occurred in six countries in the world, namely India, Indonesia, China, Nigeria, Pakistan, and South Africa. Deaths from tuberculosis are estimated as many as 1.4 million deaths plus 0.4 deaths from tuberculosis with HIV. Although the number of deaths due to tuberculosis decreased by 22% between 2000 and 2015, tuberculosis remains the ten highest cause of death in the world in 2015, according to WHO's Global Tuberculosis Report in 2016. [1]

It is remarkable that tuberculosis has posed a threat to public-health since 1800s. in the race to combat a disease that knows no boundaries, it is necessary to have a conceptual and clear understanding tuberculosis overall.[2]

In Indonesia, the prevalence of tuberculosis by 660 per 100,000 population means that as many as 0.65% of the population in Indonesia is affected by tuberculosis or equal to 1.6 million cases recorded 1 million new cases each year.[3] Persahabatan Hospital, a referral hospital located in Jakarta received every month received as many as 1000 TB cases suspected TB cases per month, while for his cases found as many as 3000 TB cases per month and 1500 of them were positive TB.[4]

The study from Indonesia, Ratna Rahayu, and colleagues showed that The multivariate analysis showed the dominant factors that influence the occurrence of TB suspect, “education”, “income”, “ashamed of having TB”, “TB treatment is very costly”, and “share dish”, distribution of health education booklet to teachers and parents.[5]

As a regency located in Central Java Indonesia, Sukoharjo stated that Case Notification Rate (CNR) achievement in Sukoharjo Regency in 2017 was the 3rd lowest after Semarang Regency and Magelang Regency, with 28.7 per 100,000 population. However, the CNR of all TB cases was ranked second lowest after Magelang District with a figure of 52.5 per 100,000 population. Sukoharjo had a population of 893,884 residents in 2017 with an estimated TB finding of 2,708 cases, but only 117 cases were reported, which consisted of 114 new cases and three repeat treatments.

Also, Sukoharjo reported 16 deaths in TB in 2016, and a Case Fatality Rate (CFR) of 0.04. In his research, it was found that new TB cases and recurrence in each puskesmas area were explained in 3 categories, namely from 12 regions there were 58% of puskesmas, or seven community health center experienced a decrease in new cases and recurrence. Whereas 42% or five community health center fluctuate or go up and up.[6]

The principles and strategies of the TB Program in 2015-2020 include strengthening TB program leadership in districts/ cities and supporting systems, increasing access to quality TB services. An increase in quality and impartial TOSS-TB (Find Treat to Heal) services to patients, control of risk factors for TB transmission, increase TB partnerships through the TB Gerdunas forum, increase community independence in TB control, and strengthen program management. One of the supporters to achieve success in eradicating TB is the application of an appropriate information system. Strengthening the health system is one of the six strategies to stop TB, which states that information weaknesses include monitoring and evaluation, including poor quality vital statistics and geographic information systems for disease surveillance. For this reason, it must be done, namely ensuring a recording and reporting system that can work in synergy with the national health information system that can be used as a model for analyzing problems and being able to improve performance in the regions.[7]

The information system for recording and reporting TB cases in the work area of the District Health Office (DKK) Sukoharjo, has not been fully integrated between sections. However, it already has its server but has not been optimized, so the data reporting process is still limited to online delivery and not real-time. It was integrated directly. So that the form of information about TB is only limited to medical data of

patients, the total number of patients in the scope of community health center presented in tables and diagrams cannot present TB cases by region through mapping.

On the other hand, Sukoharjo government five efforts related to TB namely, strengthening of legislative support, the private sector, spiritual figure, community leader and other stakeholders, strengthening health education and behavior practices, strengthening the physical environment in the company, public facilities, housing, strengthening of village health volunteer to find the suspected TB, and strengthening health workers, health facilities and easy access to services.

A preliminary study stated that there were still gaps or differences between estimates of TB case and TB cases found, including estimates of suspected resistant TB. For this reason, an innovative decision support system is needed to assist the Sukoharjo District Health Office in restricting the gaps. So, the achievement of TB suspects selection is more effective and efficient.

The study from Korea, Woo J-I, and colleagues showed that a decision support system for chronic disease administration, a recommendation message was obtained through a website service that supports self-management and screening schedule.[8]

An information system of TB developed by the ministry of health, Indonesia, SITT (Integrated Tuberculosis Information System) is a form of a web-based application that can be accessed online. The development of SITT is carried out to support TB surveillance activities and, in the process, is carried out in collaboration with the Center for Data and Information (Pusdatin) Ministry of Health of the Republic of Indonesia. SITT development aims to facilitate the implementation of further analysis between cases with logistics, cases with laboratories, logistics system alerts, inventory studies, and capture to capture. [9]

The District Health Office has been implemented SITT as mandatory from the ministry. The problems are items in SITT that are not following TB services currently related to sputum examination and display of SITT applications that are still in tables. There is no map display for TB cases desired by TB officer. SITT was designed for recording and reporting systems only so that it does not produce the other information to support another TB program.

This research aims to develop a regional-based TB program decision support system in Sukoharjo Regency, using the SDLC (System Development Life Cycle) approach or system development life cycle.

This system was to support TB program policies such as prioritizing an area in TB suspects selection.

2 Methods

This study was an information system development with SDLC (System Development Life Cycle) approach, which is a system development cycle whose activities are interrelated and sustainable. [10]

The study area was the working area of the Sukoharjo District Health department. The TB cases recorded in the district between 2018 to April 2019 were inputted in the system to graph in mapping. Many research assistants were trained to collect the data.

The interview was obtained Head of district health office, chairperson of disease control and prevention, chairperson of infectious disease control, the TB data officer, the Head of data and information, the Head of the Community health center and the Community health center TB programmer.

The theme interviewed were TB program data management in community health center and district health office as well as observing the form of information systems that are running. The inclusion criteria were considered by informed consent. In collecting data, the instruments used are observation and interview guidelines and questionnaires.

Quantitative data processing using the SPSS program and applications for qualitative data processing with the Nvivo application. The processed data will then be analyzed, namely quantitative analysis for quantitative data with a descriptive analysis of TB respondent data recorded in 2018 and until February 2019. Then describe the database correlation table, Data Flow Diagrams (DFD), and describe the support system flow decisions.

The qualitative data that has been processed is carried out qualitative analysis by narrating the results of interviews from informants.

For the SDLC method in designing a decision support system consists of the following stages:

- Conduct a system user needs study (feasibility study)
- Analyzing TB program decision support systems in the Sukoharjo district
- Perform the system design stage based on the TB Program system analysis
- Testing the system offline (off-network/ offline)
- Online system testing
- Perform system evaluations by system users
- Perform system improvements based on user input

3 Results and Discussions

Sukoharjo Regency is geographically located at 7032'17" – 7049'32" southern latitude and 110042'06,79" – 110057'33,7" east longitude. The border of Sukoharjo Regency in the north is bounded by Surakarta City, in the south with Wonogiri Regency, in the west with Boyolali Regency, and in the east with Karanganyar Regency. This research was conducted in the working area of the Sukoharjo District Health Office, which has 12 puskesmas. Still, for the system trial, one selected puskesmas was selected according to the criteria.



Fig. 1. Sukoharjo map

TB data has been managed by the district level data officers from puskesmas staff reports via SITT online, but its process is still not going well.

TB officer in community health center level sent the TB recording by excel files, and email it to the district. These data are only recording and reporting information. Still, they can not explain or assist in making policies related to which regional priorities are emphasized in the screening of suspects by knocking door and mass sputum activity test (*ketuk pintu* and *grebek dahak*).

Currently, the existing information systems used can not provide enough to support the decision, such as prioritizing an area in TB suspects collection.

Of this research, the district health office of Sukoharjo requested that the system not increase the workload of TB officers, but rather make it easier to help make TB program decisions, especially in TB suspects screening. Besides, the health department hopes that the system does not need to re-input and color the map display. The map that was displayed to be made more informative by displaying the classification of risk is low, medium, and high.

Results of TB case data collection on cases recorded in 2018 and 2019 by sex as follows:

Table 1. Distribution of TB Patients by Sex

Sex	Frequency	Percent (%)
Female	155	56.99
Male	117	43.01

Based on the distribution table of TB patients by sex recorded in 2018 and early 2019, female TB patients by 56.99% higher than male TB patients by 43.01%.

Whereas the types of TB obtained from TB cases recorded in 2018 and early 2019 are as follows:

Usecase diagram made to detect actors in the system, which consists of the user such as :

- Administrators who have full access rights where the administrator can access all forms in the system.
- Public Health Officer or District Health Office have access to all forms except district data collection, with the main task of monitoring performance in each puskesmas and programs proposed by puskesmas.
- The head of the primary health care has access to register the users for the puskesmas staff and has a program to manage the area.
- TB programmer was an officer on the Community health care level who have access to data on TB patients in the villages and provide input to the puskesmas head to carry out TB programs in their area.

2. Creating an *Activity Diagram* to illustrate activity on the system.

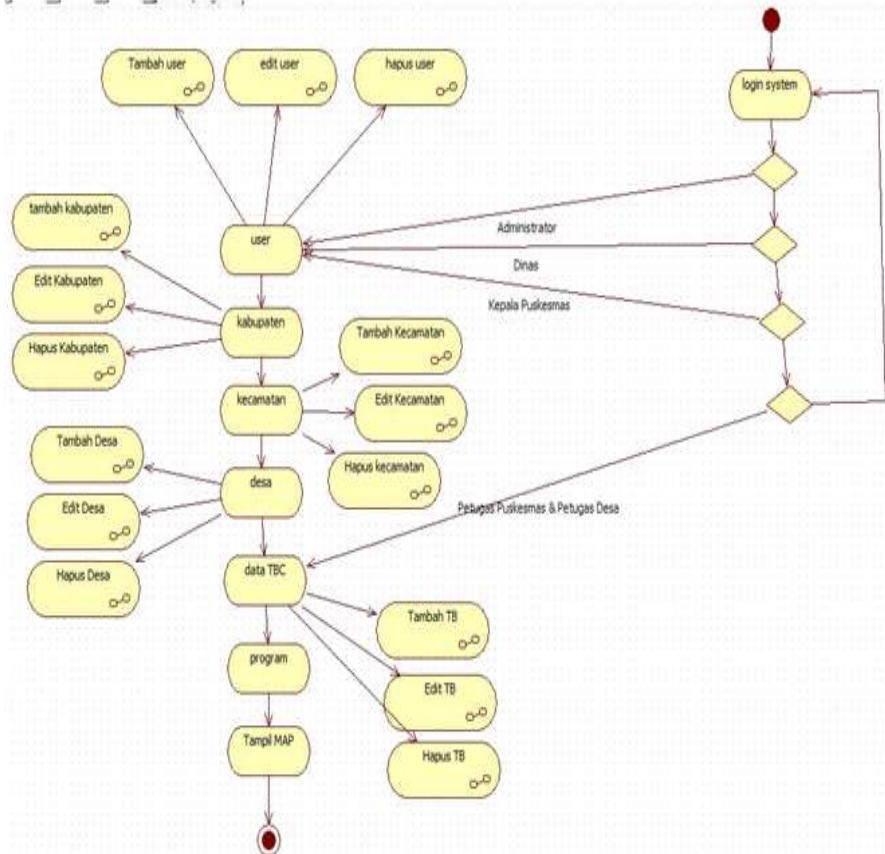

Fig. 4. Activity diagram

The activity diagram of the system created illustrates the system login activities as an administrator, department, head of puskesmas, and puskesmas officers. And the right of access to the table can be added and edited data.

3. Creating *Sequential Diagram*

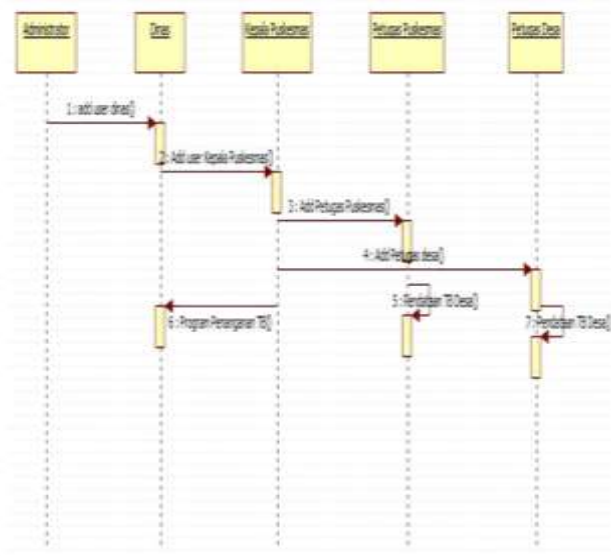

Fig. 5. Sequential Diagram

Sequential diagram of the system that has been made is the following :

- The initial administrator will create a user for service
- After that, the Health service officer will create a user for each head of community health center
- The head of the puskesmas creates users for officers and villages and makes programs based on input from community health center and village officials
- Community health center officer and village staff will collect TB data

4. Making the Normalization of data for the system developed. Normalization of this data consists of 2 stages:

- The use case diagram developed from stage 1NF. Then the tables used are consisting of id_desa and villages, id_kec and sub-districts, id_kab, and districts.
- 2NF normalization as the second normalization form in the village, sub-district and district user field tables had been separated into individual tables where relations in the user table use the id_desa field to relate to the village table, id_kec to relate to the subdistrict table, and id_kab to relate to the district table.

5. Making an Entity Relationship Diagram (ERD) was to form relations between tables. It can be seen in Figure 6 below.

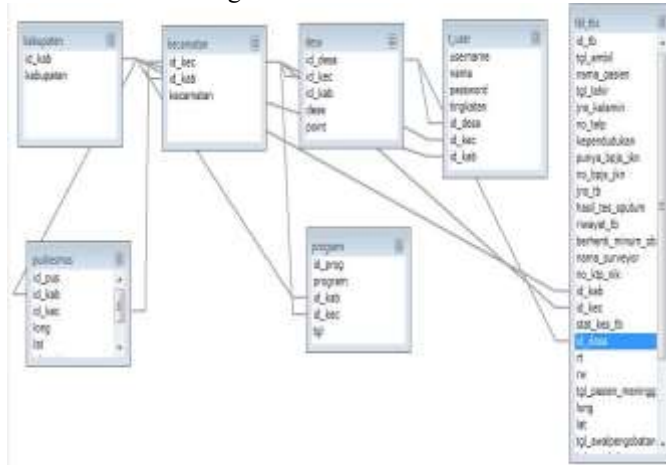

Fig. 6. ERD of a new system

6. Program Design and Implementation

This activity is the stage for designing menus in the TB Program decision support system. The program used to design using web-based programs and database programs using MySQL. The design below:

A. Username and password user on login form used for users to enter the system, show by figure 7:



Fig. 7. Login menu of Implementation program

On this login form, the user had to fulfill the right username and password as first registration, if in the database match with the username and password so that it will be directed to inside TB web appropriate with the user level. If there wrong user and password entered on the login form, there would be an error message.

B. Main page display belonging on SPK-TB

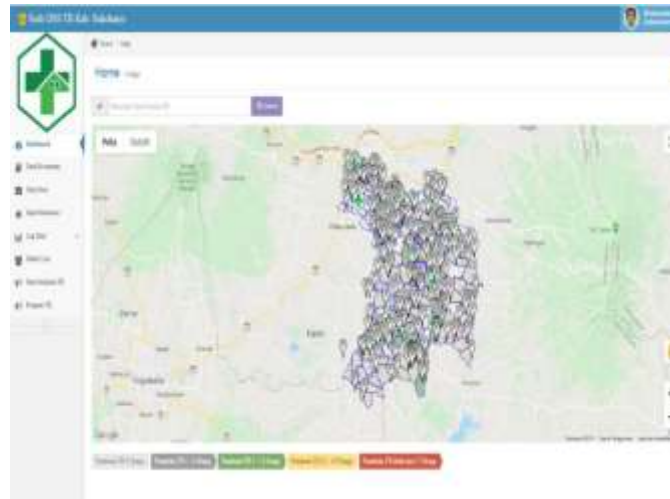

Fig. 8. SPK TB main page of the Implementation program

The main page, when the user log-in, it will show maps of Sukoharjo Regency and points of TB patient corresponding with recorded data, also color shows the number of TB patients. White color show amount of 1 – 4 patients, green color 5 – 11 patients, yellow color 12 – 16 patients, and red shows ≥ 17 patients in the village.

C. The display of TB patient fulfillment form equipped with a TB patient input menu and headed village. TB patient data not only can be inputted with computers but also with *handphones* or *smartphones* because of this system, SPK-TB, program created as an android based application.



The figure displays three sequential screenshots of a web-based TB Patient Form for Implementation Program. The top screenshot shows the 'Patient Information' section, which includes fields for Name, Sex, Age, and Address. The middle screenshot shows the 'Medical History' section, which includes fields for TB Type, TB Status, TB Treatment, TB Diagnosis, TB Date, and TB Location. The bottom screenshot shows the 'Map' section, which includes a map of a region and a red pin indicating the patient's location.

Fig. 9. TB Patient Form for Implementation Program

This TB input form used by community health center officer or village coordinator that visits TB patient home. Both input appropriate patient data in this form, and this form equipped with maps where patients live.

D. The display of the TB program menu conducted by the community health center officer.

Fig. 10. TB Program Implementation

The TB Program menu was used by the puskesmas to include activities that were following the TB case findings in each puskesmas. If TB cases are found to be greater than 17, the Head of the Community Health Center is required to provide a program that aims to deal with the area affected by TB where the TB Program will be followed up by the Sukoharjo District Health Service as input for future steps. By entering the activity into the TB Program Form menu shown in the following figure:

Fig. 11. Menu Form of TB Program Implementation

7. Implementation of the TB Decision Support System trial; at this stage, there are two activities:

- Internal testing is carried out by testing the system that was made, namely SPK-TB web-based, by the research team offline or offline by activating the interface created and seeing the smooth system that has been created using computers and mobile phones. After the offline trial has been successful, the next trial was an online trial using data communication or online to see the location of TB patients based on villages in Sukoharjo Regency.

- An external trial for SPK-TB is carried out using a computer device and mobile phone or smartphone. In using this system on a computer device by accessing the web that had been made, namely <https://sisfo-dss-tb.com/>. To be able to run SPK on mobile or smartphone is required by logging in or logging on to the web <https://sisfo-dss-tb.com/> which will then appear in the bottom selection of images to download the application for the mobile device.

8. Evaluation of the system trial in the field with the system user, this activity is carried out in 2 stages:

- Phase 1 of the system trial at the Sukoharjo Health Service Officer was obtained there directly accessing the web-based SPK-TB and looking at the menus and data contained in the system using a laptop or mobile device. Based on this trial, it was found that there was data on the date of death that was filled in automatically; the location of the pointer was not right in the destination village. There were additional data for the TB program that needed to be filled in by the Head of the Community Health Center.
- Phase 2 of the trial at the selected Community Health Center was Bulu Community Health Center in Sukoharjo District, which is the puskesmas located farthest from the Sukoharjo DKK and had recorded and reported with SITT. This trial involves the village coordinator or village midwife and directly practices how to input TB patient data using the SPK-TB application using a mobile phone or smartphone owned by each village midwife. Based on the results of the Phase 2 trial, it was found that the TB Community Health Center programmer and the village midwives were able to input data using mobile and laptop devices.

Research carried out in several stages to achieve research objectives, there are :

- a) The users were developed at two levels of decision making of the TB program at the level of the work area of the health department, namely the level of district or city health service and puskesmas. They refer to a statement from the Head of the Disease Prevention section (P2) at the District Health Office level, which requires a system that facilitates decisions for the TB Program, including cross-sectoral involvement. Based on the research of the health service system in Uttar Pradesh, India, which explains that the provision of traceable information at all levels of management is the key to strengthening the health system and can improve the quality of health services.[11] Analysis of needs based on research on Information Systems Requirements Analysis in Yogyakarta cites from B.Yanmarshus stated that the needs analysis is the main key to get information about the software needed by the user [12]
- b) Analyzing the TB Program decision support system in the Sukoharjo district, it was found that the policymakers were at the district and puskesmas level. Related to the territorial-based suspecting netting policy, so far, TB data management at the Sukoharjo PHO level is managed by data officers who are supported by TB programmers in puskesmas using SITT. Also, there is the use of P-care in health centers. However, the existing system has not been able to display in the form of

- mapping, so we need a system that can support decisions for the management level in the screening of TB suspects. It is consistent with a limited set of processes related to the use of data for decision making at the district level. [13]
- c) The levels of users were developed, including the village level. Village coordinator or village midwife who contacts directly to TB sufferers' locations, making it easier for Community Health Center to monitor TB distribution based on reports from village coordinators or village midwives. Whereas at the DKK Sukoharjo level, they received reports from the puskesmas by looking at the spread of TB patients in their working area and were able to monitor the performance of the Community Health Center based on TB program records. The existing information system is not yet effective because there are still many programs that have not been implemented well. After all, many Community Health Center are late or not the same once report the data to the Rokan Hilir District Health Office so that problems in the health sector have not been resolved. [14]
 - d) The system designed was to emerge the objects to support the decision. The object and how it relates to one another with the relationship between aggregation and generalization.[15] in the usecase diagram that has been made can be seen by the actors of the new system consisting of actors based on management level, namely administrator, department, head of Community Health Center, and Community Health Center and village officials, which have their respective roles under their duties.
 - e) Trial the system was undertaken to get whether the program designed can be run well or not.
 - f) Other issues were the limitations encountered in the system Village area-based TB program decision support and trial run smoothly.
 - g) The Sukoharjo DKK can use the implementation of online system trials conducted in the field directly to find out whether the system created by using internet access. It was following research on the development of health information systems found that the last stage in the development of information systems is by testing the system that results in testing validation that all functional and non-functional needs have been met by the system designed. Incompatibility testing, the system results have obtained the information built can run well in almost all browsers. [16]

4 Conclusions

Based on the study of the needs of system users in the Sukoharjo DKK and Bulu district of Sukoharjo District, it was found that at the management level, the puskesmas needed an accurate TB patient report from the village coordinator. Whereas at the management level of Sukoharjo requires a decision support system that can see the distribution of TB cases accurately and precisely. TB Program Decision Support System so far has not been in the form of web and android because the Sukoharjo got TB Program reports based on reports from puskesmas in its working area using SITT, while SITT is only in the form of recording and reporting in the form of numbers and not in the form of mapping that can facilitate the

management level sees the distribution of TB cases in their working area. A health information system was developed and tested on several levels: district, Community Health Center as sub-district, a village as data input officer. The Community Health Center level could get information in mapping and offer the TB program based on its decision.

Acknowledgments. This research ran smoothly with the support of various parties. For that, we say many thanks to Badan Penelitian dan Pengembangan Kesehatan (Litbangkes) Kemenkes Republik Indonesia (Health Research and Development Agency, Ministry of Health Indonesia) has given the 2019 IPTEKKES research grant to the research team; Dean of the Faculty of Health, Science Dian Nuswantoro University, and their staff; Dean of the Faculty of Health Sciences Muhammadiyah Surakarta and his staff; Head of the Health Office of Sukoharjo Regency, Central Java and their staff; Head of Primary Health Care Bulu, Sukoharjo Regency and their staff; Colleagues and parties who have helped to carry out the 2019 IPTEKKES research to completion smoothly.

References

- [1]. Dinas Kesehatan Provinsi Jawa Tengah. Profil Kesehatan Provinsi Jawa Tengah tahun 2018 [Internet]. Semarang; 2018. Available from: http://dinkesjatengprov.go.id/v2018/dokumen/profil_2018/files/downloads/Profil_Jateng_2018_cetak.pdf
- [2]. Fogel N. Tuberculosis: A disease without boundaries. *Tuberculosis* [Internet]. 2015;95(5):527–31. Available from: <http://dx.doi.org/10.1016/j.tube.2015.05.017>
- [3]. Rina Anggraeni. Kelompok Usia Produktif Rentan Terkena Tuberkulosis. *Sindo News* [Internet]. 2017 Nov; Available from: <https://lifestyle.sindonews.com/read/1261459/155/kelompok-usia-produktif-rentan-terkena-tuberkulosis-1511898948>
- [4]. Ramadhani B. Usia Produktif Rentan TBC Kebal Obat _ *Republika Online*. *Republika News* [Internet]. 2012; Available from: <https://www.republika.co.id/berita/nasional/umum/12/11/23/mdxynt-usia-produktif-rentan-tbc-kebal-obat>
- [5]. Rahayu SR, Katsuyama H, Katsuyama M, Ota Y, Djaja Semadi NP. Tuberculosis Suspect in the Companies in Semarang District Indonesia; Case-Control Study. *J Kesehat Masy*. 2017;12(2):167–76.
- [6]. Setiyadi NA, Bagaskoro A, Dyah R, Magdalena A. The 8 th University Research Colloquium 2018 Universitas Muhammadiyah Purwokerto GAMBARAN KASUS TUBERKULOSIS TAHUN 2013-2016 DI JAWA TENGAH : STUDI DESKRIPTIF DI KABUPATEN SUKOHARJO TUBERCULOSIS CASES GRAPHING IN 2013-2016 IN SUKOHARJO REGENCY : A DESCRIPTIVE. 2018;2016. Available from: <http://repository.urecol.org/index.php/proceeding/article/view/354/345>
- [7]. Kementerian Kesehatan RI. Prinsip dan strategi Program TB tahun 2015 -2020. 2015; Available from: <https://www.tbindonesia.or.id/page/view/7/prinsip-dan-strategi-program>

- [8]. J.-I. W, J.-G. Y, Y.-H. L, U.-G. K. Healthcare decision support system for administration of Chronic diseases. *Healthc Inform Res* [Internet]. 2014;20(3):173–82. Available from: <https://europepmc.org/articles/PMC4141131;jsessionid=E23A922F0692B766938EDF5EEA1D157B>
- [9]. RAMADHANI NR. EVALUASI SISTEM INFORMASI TUBERKULOSIS TERPADU (SITT) DI RUMAH SAKIT PARU RESPIRA YOGYAKARTA DAN DINAS KESEHATAN PROVINSI DAERAH ISTIMEWA YOGYAKARTA DENGAN METODE TECHNOLOGY ACCEPTANCE MODEL (TAM) [Internet]. Universitas Muhammadiyah Surakarta; 2018. Available from: http://eprints.ums.ac.id/68506/12/Naskah_Publikasi-18.pdf
- [10]. Ralph M. Stair GR. Principles of information systems [Internet]. 10th ed. USA: 10th ed. USA: Course Technology, Cengage Learning; 2012. Available from: http://site.iugaza.edu.ps/kdahleez/files/2014/09/stair78292_0538478292_02.01_chapter01.pdf
- [11]. Kapadia-Kundu N, Sullivan TM, Safi B, Trivedi G, Velu S. Understanding health information needs and gaps in the health care system in uttar pradesh, India. *J Health Commun* [Internet]. 2012;17(SUPPL. 2):30–45. Available from: <https://www.tandfonline.com/doi/pdf/10.1080/10810730.2012.666625?needAccess=true>
- [12]. Alimuddin Yasin, MZ Yumarlin TF. Analisis Kebutuhan Sistem Informasi di LPK RJ-COMP Yogyakarta. *Semin Nas Inform* [Internet]. 2017;1(1):111–6. Available from: <http://e-journal.potensi-utama.ac.id/ojs/index.php/SNI/article/view/251>
- [13]. Raeisi AR, Saghaciannejad S, Karimi S, Ehteshami A, Kasaei M. District health information system assessment: A case study in Iran. *Acta Inform Medica* [Internet]. 2013;21(1):30–5. Available from: <https://www.ncbi.nlm.nih.gov/pmc/articles/PMC3612431/pdf/AIM-21-1-8.pdf>
- [14]. Isnaini. Efektifitas Pelaksanaan Sistem Informasi Kesehatan Online Pada Dinas Kesehatan Kabupaten Rokan Hilir. *Jom Fisip* [Internet]. 2017;4(2):1–14. Available from: <https://jom.unri.ac.id/index.php/JOMFSIP/article/view/15121/14668>
- [15]. Dewi LP. Perancangan Sistem Informasi Dengan Metode Use Case Driven Object Modelling (Studi Kasus: Verifikasi Data Pada Penerimaan Siswa Baru). 2011; Available from: http://repository.petra.ac.id/15654/1/Use_Case_-Full_Paper.pdf
- [16]. Herlambang TW, Aknuranda I, Saputra MC. Pengembangan Sistem Informasi Kesehatan Berbasis Web Berdasarkan Model Organisasi Dan Manajemen Kesehatan Primer “ANDAL.” *J Pengemb Teknol Inf dan Ilmu Komput Univ Brawijaya* [Internet]. 2018;2(4):1602–10. Available from: <http://j-ptiik.ub.ac.id/index.php/j-ptiik/article/view/1282/462>

Delayed Onset of Muscle Soreness and The Activation of The Immune System

Mohammad Arif Ali¹, Setya Rahayu², Yang, Chia-En³, Nandaru Fajar Sumirat⁴, Bayu Pangestu⁵, Gustiana Mega Anggita⁶, Sugiarto⁷, Fuadah Nor Wiqoyatul Milla⁸
{hiarifalikh@mail.unnes.ac.id¹, setyarahayu@mail.unnes.ac.id², yce@mail.npust.edu.tw³}

Universitas Negeri Semarang, Semarang, Indonesia^{1,2}
National Pingtung University of Science and Technology, Pingtung, Taiwan³

Abstract. Inappropriate exercise prescription is one of many factors to sport injuries. Delayed onset of muscle soreness triggers the inflammatory processes. Therefore knowing the process of DOMS, physical exercise benefits, and the process of immune system activation after physical exercise will give us better understanding to create precise prescription. Original studies within last ten years were considered, other references were used only to support the story-lines. The codifying/compilation stage, followed by analysis and synthesis, then analysis to synthesis were performed sequentially to provide acceptable answers. Eccentric contraction and high intensity exercise cause DOMS. DOMS sequences: mechanical damage; inflammation; and free radical proliferation. Physical exercise benefits both in physical and mental health. Neutrophil, macrophages as natural killer cells are types of the main cellular vulnerable congenital of immune system, changed because of physical exercise. Proper methods and intensity in physical exercise are keys to activates immune system.

Keywords: physical exercise; DOMS; immune system.

1 Introduction

The human immune system has important and complex task in human survival. The immune system can identify harmful microbes and microbes that are beneficial to the human body [1]. Physical exercise has become a necessity for every individual in this modern era, it is because to increase the immune system in the human body is one of physical exercise purposes. Once immune system become stronger, it leads to improve health [2].

Unfortunately, besides having positive effects, acute physical exercise could brings undesirable effects (injury) especially when physical exercise is not following the proper exercise prescription. Athletes are including in high risk of injury, when prolonged physical exercise or too heavy exercise is performed [3]. Injury causes muscle trauma, based on the type of trauma or muscle strain are classified into three grades: grade I (Mild damage to individual muscle fibers), grade II (More extensive damage with more muscle fibers involved), type III (Complete rupture of a muscle or tendon). Grade I strain is characterized by microscopic damage to muscle fibers

which then results in pain and swelling [4]. Muscles will respond to increased intensity of exercise with pain, and this type of pain is commonly considered as Delayed Onset of Muscle Soreness or DOMS [5].

Based on the description above, the objectives of this study are: 1) To describe the process of delayed onset of muscle soreness as part of physical exercise effects. 2) To elaborate on the benefits of physical exercise. 3) To describe the process of immune system activation after physical exercise.

2 Materials and Methods

Materials, this is a narrative review, data in this paper are secondary. Mainly original studies within last ten years of being published were considered on this paper, additionally other references were being used only to support the storylines in order to answer the research objectives. Materials were obtained from data stations such as Google Scholar, PubMed, ResearchGate, Reports, Blogspots, News Paper, etc. Twenty two papers cited in this study, eighty papers (82%) were published between years 2010 to 2020; two papers (9%) year 2009 and 2003; last two papers (9%) year 1993 and 1991.

Methods, there are three stages must be done sequentially in order to provide acceptable answers for the questions. 1) The Codifying or Compilation Stage is when investigators doing collection and sorting all related materials from sources. 2) Analysis and Synthesis Stage, profound and detailed examination (extracting data) on how data from chosen materials could be constructed into data interpretation. 3) Conclusion Drawing is the last stage to end the process of literature study and to state the novelty of study.

3 Results and Discussion

Since this is a narrative review which all data in this paper are secondary, the limitations we do have is more than systematic review study. In this paper we only focus on specific issue, there are DOMS, physical exercise benefits, and the activation of immune system post exercise.

3.1 DOMS as acute effect of physical exercise

DOMS is ultrastructural muscle damage, it is often associated with increased pain, stiffness, swelling, and mechanical changes in the joints [7]. DOMS causes pain in the muscles and will worsen when used to contract [8]. DOMS occurs because of extra muscle contraction and also a contraction which is not usually done by the people called eccentric contraction, DOMS is also considered as strain grade I [9].

Muscle stiffness due to DOMS can limit movement (decreased range of motion) and interfere onto daily activities (Pearcey et al., 2015). DOMS not only attacks an athlete, but DOMS also might be experienced by untrained people [10] or people who engage in eccentric physical exercise [7]. DOMS occurs within 12 hours and then

peaks within 24 to 72 hours after practice and takes five to seven days to heal [10], [11].

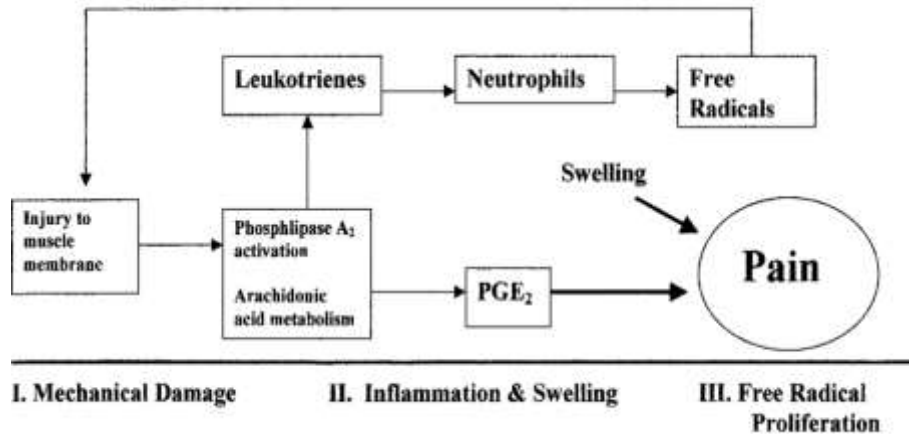

Fig. 1. Schematic showing possible sequence of injury of delayed onset muscle soreness. Figure is adopted from Connolly, Declan A.J., Sayers, Stephen E., Mchugh, Malachy P., 2003 [6].

Inflammation processes occur underlying DOMS condition, this process involving leukocytes that is remarkable biomarker of DOMS [12]. Leukocytes consisting of neutrophils, lymphocytes, basophil, eosinophils, and monocytes [13]. Monocytes are one of the most important in the process of inflammatory [14]. Microscopic damage on muscle fibers occurred because DOMS, and then there is the repair process conducted by muscle fibers monocytes after receiving signals from microscopic damage to work on the process of angiogenesis and fibrosis [15]. Mechanical damage is common initiation cause DOMS (there is an injury from performing physical exercise or sport to muscle membrane), then followed by inflammation (swelling in physical appearance) activation as body response, the end what cause the pain sensation is free radical proliferation, (Figure 1).

3.2 Benefits of physical exercise on health

Physical exercise is useful to maintain muscle strength especially in elderly and reduced risk of death caused by diseases [17]. Moderate exercise can reduce the risk of chronic diseases in human, including cardiovascular disease, type 2 diabetes, and cancer [18]. Physical exercise affecting our immune system, particularly moderate exercise can provide positive effects on immune system improvement [19]. Furthermore, physical exercise also has many benefits on mental health management, start from improving mental health, improving mood, and neuroplasticity using the factor neurotrophic of the brain [20]. Less of physical activity increased risk of health problems [18].

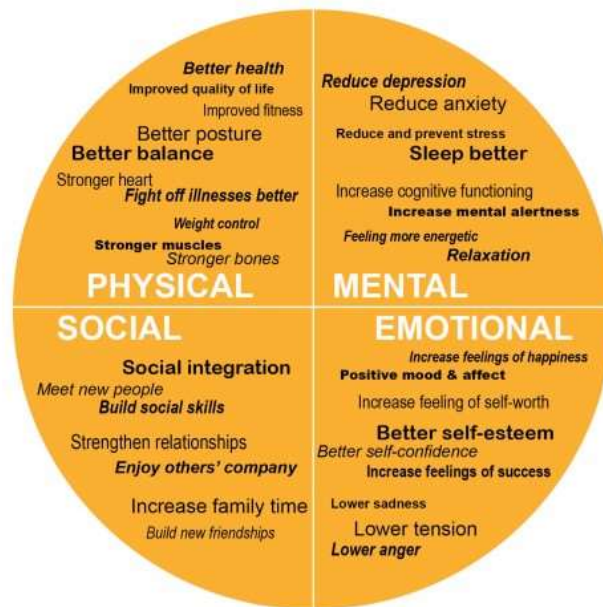

Fig. 2. Benefits of physical exercise on physical, mental, social, and emotional health. Figure is adopted from <https://www.enoughwiththetmadness.com/blog/the-benefits-of-physical-activity-and-so-much-more> [16].

3.3 Sports activates immune

The effect of exercise on immune system varies different depending on the intensity and methods used for physical exercise. The higher intensity would give better results for good immune when it is conducted with the right prescription. However, if it is mistaken, then the risk of injury become higher. For example, is boxing and running, they have different risk of injury. Sports can influence the immune system in a different way [21].

Regular physical activity can be diversifying the act of anti-inflammatory. Cooperation between organs that are mediated by physical activity set the leading in improving cytokines anti-inflammatory and declines in a pro-inflammatory cytokine. When muscle contract, myokin takes part in sent down chronic inflammation. Particles of a muscle that was revealed by interleukin recognized as myokin apleiotropic in modulation metabolism immune and inflammatory [20]. The immune main defense system is body against pathogenic. Neutrophil, macrophages a natural killers are the typea of the main cellular vulnerable congenital of immune system, changes because of physical exercise. Then neutrophils capable of killing bacteria through the release of enzymes and through the secretion of reactive oxygen species .

According to Pedersen's investigation about the effect of static cycling on ergometer cycle for 60 minutes in a trained and healthy young man, with target intensity 75% of VO2Max. Showed that acute effect of physical exercise is very influential to

improve human immunity (increased leukocytes, lymphocytes, and neutrophil). This is one of the evidence showing that exercise is actually a challenge to our body, (Table 1).

Table 1. Effects of ergometer cycling for 60 minutes (75% VO₂ MAX). Table is adopted from Pedersen, 1991.

Immune Agents	During Exercise	2h Post Exercise
Leukocytes (10 ³ /μl)	↑ Increased	↑ Increased
Lymphocytes (%)	↑ Increased	↑ Increased
Neutrophil (%)	↑ Increased	↑ Increased

Leukocytes are human defense system or commonly called white blood cells. Leukocytes consist of neutrophils, lymphocytes, basophils, eosinophils, and monocytes [13]. The increase of leukocytes is needed by the body as the immune system. Moreover, a study conducted by Laeto showing the effect of physical exercise on changes in the number of leukocytes. Subjects in the study were trained young men with an age range of 18-24 years old. Physical exercise performed for 60 minutes can increase the number of leukocytes. This increase is caused by stress and the burden received by the body due to physical exercise. This also relates to blood transfer activities from lymph vessels to blood vessels. Data are shown in table 2 below:

Table 2. Effects of physical exercise on leucocyte levels in trained young men. Table is adopted from Laeto et al., 2017.

Immune Agents	Average ± before the intervention	Average ± after the intervention	P
Leukocytes (10 ³ /μl)	7912±968	9387±2736	0,013
Neutrophils (%)	4359±718	6462±2783	0,005
Eosinophils (%)	206±130	162±122	0,024
Basophils (%)	53±20	55±16	0,493
Lymphocytes (%)	2689±480	2107±649	0,002
Monocytes (%)	605±124	601±235	0,928

Additionally, a reduction of normal functioning immune because of age is called Immunosenescence. It is marked by impaired immune function cellular and an increase in inflammatory activity. Age affects the innate immune system (macrophages, neutrophil, the dendrites, and natural killer cells) and adaptive immune system (lymphocytes-T and lymphocyte-B). However, Increasing physical exercise can increase sensitivity to infection (body is ready to combat any pathogen) [17].

4 Conclusion

In brief, sequences of DOMS are 1) Mechanical damage, 2) inflammation/swelling, 3) Free radical proliferation. Physical exercise benefits both in physical health and mental health. The proper intensity and methods used for physical exercise

is a key to activates our immune system. Neutrophil, macrophages as natural killer cells are the types of the main cellular vulnerable congenital of immune system (the innate immune system), changes because of physical exercise.

Acknowledgments. This study is part of an investigation about effects of high density foam roller on leucocytes and monocytes levels as indicators of delayed-onset muscle soreness (DOMS) post long distance running in trained young males. This study was granted by Faculty of Sports Science, Universitas Negeri Semarang (*DIPA FIK UNNES Tahun Anggaran 2020. Nomor Surat Perjanjian Penugasan: 2.4.5/UN37/PPK.3.1/2020*).

References

- [1]. S. K. Lundy, "The immune system , in sickness & in health — part 1 : microbes and vaccines," *Immune Syst. Fight. Infect. Microbes*, vol. 6, no. September, pp. 1–7, 2018.
- [2]. P. Krustup, J. Dvorak, and J. Bangsbo, "Small-sided football in schools and leisure-time sport clubs improves physical fitness , health profile , well-being and learning in children," *Br. J. Sports Med.*, vol. 50, no. 19, pp. 1166–1167, 2016.
- [3]. A. W. Ilmawan, "The effect of doms massage on pain reduction and increased range of motion (ROM) and function in the case of delayed onset muscle soreness (DOMS) in the legs," Universitas Negeri Yogyakarta, 2018.
- [4]. D. Delos, T. G. Maak, and S. A. Rodeo, "Muscle injuries in athletes: enhancing recovery through scientific understanding and novel therapies," *Sport Heal.*, vol. 5, no. 4, pp. 346–352, 2013.
- [5]. [5] P. B. Lewis and D. Ruby, "Muscle soreness and delayed-onset muscle," *CSM*, vol. 31, no. 2, pp. 255–262, 2012.
- [6]. M. M. H. D. Connolly, S. Ayers, "Treatment and prevention of delayed onset," *J. Strength Cond. Res.*, vol. 17, no. 1, pp. 197–208, 2003.
- [7]. T. Hotfiel et al., "Advances in delayed-onset muscle soreness (DOMS): part i : pathogenesis and diagnostics delayed onset muscle soreness – teil i : pathogenese und diagnostik authors mechanisms and pathogenesis," *Sport. Sport.*, vol. 32, no. 4, pp. 243–250, 2018.
- [8]. L. Stefanelli et al., "Delayed-onset muscle soreness and topical analgesic alter corticospinal excitability of the biceps brachii," *Med. Sci. Sport. Exerc.*, vol. 51, no. 11, pp. 2344–2356, 2019.
- [9]. R. Heiss, C. Lutter, J. Freiwald, M. W. Hoppe, C. Grim, and K. Poettgen, "Advances in delayed-onset muscle soreness (DOMS) – part ii : treatment and prevention delayed onset muscle soreness – teil ii : therapie und prävention authors," *Sport. Sport.*, vol. 33, no. 01, pp. 21–29, 2019.
- [10]. G. E. P. Pearcey, D. J. Bradbury-squires, E. J. Drinkwater, D. G. Behm, and C. Duane, "Foam rolling for delayed-onset muscle soreness and recovery of dynamic performance measures," *J. Athl. Train.*, vol. 50, no. 1, pp. 5–13, 2015.
- [11]. S. P. Selkar, G. J. Ramteke, and A. K. Dongare, "Effect of eccentric muscle training to reduce severity of delayed onset muscle soreness in athletic subjects," *Eur. J. Gen. Med.*, vol. 6, no. 4, pp. 213–217, 2009.

- [12]. I. G. Fatouros and A. Z. Jamurtas, "Insights into the molecular etiology of exercise-induced inflammation: opportunities for optimizing performance," *J. Inflammation Res.*, vol. 9, pp. 175–186, 2016.
- [13]. B. K. Pedersen, "Influence of physical activity on the cellular immune system: mechanisms of action," *J. Sport Med.*, vol. 12, no. 18, pp. 23–29, 1991.
- [14]. A. R. Jajtner et al., "Mediators of monocyte migration in response to recovery modalities following resistance exercise," *J. Mediat. Inflamm.*, vol. 2014, pp. 1–9, 2014.
- [15]. T. M. Best, B. Gharaibeh, and J. Huard, "Stem cells, angiogenesis and muscle healing: a potential role in massage therapies," *Postgrad. Med. J.*, vol. 89, no. 1057, pp. 666–670, 2013.
- [16]. "The benefits of physical activity and so much more," 2019. [Online]. Available: <https://www.enoughwiththetmadness.com/blog/the-benefits-of-physical-activity-and-so-much-more>.
- [17]. V. Valdiglesias et al., "Immune biomarkers in older adults: role of physical activity immune biomarkers in older adults: role of physical activity," *J. Toxicol. Environ. Heal. Part A*, vol. 00, no. 00, pp. 1–16, 2017.
- [18]. S. Estruel-amades, M. Camps-bossacoma, M. Malén, J. P. Francisco, and M. Castell, "Alterations in the innate immune system due to exhausting exercise in intensively trained rats," pp. 1–12, 2020.
- [19]. G. P. Tilz et al., "Increased immune activation during and after physical exercise," *Immunobiology*, vol. 188, no. 1–2, pp. 194–202, 1993.
- [20]. R. Codella, L. Luzi, and I. Terruzzi, "Exercise has the guts: How physical activity may positively modulate gut microbiota in chronic and immune-based diseases," *Dig. Liver Dis.*, vol. 50, no. 4, pp. 331–341, 2018.
- [21]. J. G. B. Van Dijk and K. D. Matson, "Integrative and comparative biology ecological immunology through the lens of exercise immunology: new perspective on the links between physical activity and immune function and disease susceptibility in wild animals," vol. 56, no. 2, pp. 290–303, 2016.
- [22]. A. Bin Laeto, R. Natsir, and M. A. Arsyad, "Effect of night futsal on the number of leukocytes and the count of leukocytes in young adults," pp. 35–40, 2017.

Perception of HIV/AIDS Risk Behavior among Students in Central Java Indonesia

Muhammad Azinar¹, Alfiana Ainun Nisa², Furqonawati³
 {azinar.ikm@mail.unnes.ac.id¹, alfiana_ainun@mail.unnes.ac.id², furqonawati@gmail.com³}

Universitas Negeri Semarang, Semarang, Indonesia^{1,2,3}

Abstract. The prevalence of HIV/AIDS in all regions in Indonesia is always increasing, including in Central Java. This case also often occurs in the group of adolescents aged 15-24 years and having status as students. Cumulatively until 2018, there have been 27,000 students in Central Java indicated as having HIV/AIDS. These risk factors are caused by their behavior, especially premarital sexual behavior. These risky behaviors can be caused by their perception. This research uses descriptive analytic design. The study population was high school students in Central Java. A sample of 322 students was divided proportionally between men and women. Data analysis was performed descriptively and comparatively. The results showed that most students had a moderate perception of HIV/AIDS risk behavior. There is no significant difference in perception between male and female students and there are differences in perceptions between students in urban and rural areas towards HIV/AIDS risk behavior.

Keywords : students, risk behavior, HIV / AIDS

1 Introduction

AIDS is a disease which until now has become a public health problem in almost all countries in the world, including Indonesia. Every day new cases of HIV/AIDS occur and the number is always increasing. The highest distribution of HIV/AIDS cases occurred in the age group of 20-29 years (32.1%), the age group of 30-39 years (31%), 40-49 years (13.6%), 50-59 years (5.1%), and 15-19 years (3.2%). Based on sex, the percentage of HIV/AIDS in men is 58% and 33% for women. Meanwhile 9% did not report gender [1].

Central Java Province is the region that currently has the fifth highest cumulative number of HIV/AIDS in Indonesia. Over the past three years there has been a significant increase in new cases. Since it was first discovered in Central Java until 2018 there have been 23,603 cases, 1,672 of whom died of AIDS [1].

Cases of HIV/AIDS also occur in many groups of adolescents aged 15-24 years and have the status of students. The Central Java AIDS Commission recorded that cumulatively until 2018, there were 27,000 students in Central Java indicated to have HIV/AIDS. Most students are infected with the HIV/AIDS virus because of having same sex or men who have sex with men (MSM) and men with women [2].

The facts above show that nationally and regionally in Central Java, adolescents and students who have become a risk group for HIV/AIDS. These risk factors are caused by their behavior, especially premarital sexual behavior. UNICEF estimates that new HIV/AIDS cases in adolescents will continue to increase every year. From 250,000 cases in 2015 will increase to almost 400,000 cases by 2030 and will cause AIDS as the leading cause of adolescents death in the world [3].

Adolescence is the most difficult period for everyone. The most critical developmental period in the stages of human life. The period of adolescent development is characterized by emotional changes, a high curiosity, like to try new things so that it can have an impact on the vulnerability of certain diseases, including HIV/AIDS [4].

Gender influences the risk of HIV/AIDS transmission. Adolescent girls have a greater risk of HIV/AIDS. UNICEF data mentions from 4 new cases of HIV/AIDS in adolescents aged 15 to 19 years, 3 cases of which occurred in adolescent girls [3]. There are differences in perceptions regarding sexuality between boys and girls. Many social norms in society place men as having a higher role and must be followed by women. This social norm that ultimately makes it difficult for women to protect themselves from the risk of HIV/AIDS infection. In addition, in traditional norms, virginity for unmarried adolescent girls has become a barrier for them to seek important sexual health information, including knowledge about HIV risk, so as to maintain their virginity, many adolescents are involved in alternative sexual behavior, such as sex anal, which can also increase the risk of contracting HIV [5].

The residence can also affect adolescent perceptions about the risk of HIV/AIDS. Awareness of how HIV/AIDS can be transmitted. Adolescent girls in urban areas 38% have a good awareness, while adolescents in rural areas are 24%. The majority of adolescent girls in urban areas know about perceptions that are still wrong regarding HIV/AIDS transmission (43%) and 36% adolescent girls who know about ways to protect from HIV/AIDS [6].

The biggest risk factor for HIV / AIDS transmission is caused by risky sexual behavior [7]. Risk behaviors are behaviors that have the potential to put people at danger or risk significant harm [8]. Risk sexual behavior is sexual activity and lifestyle that puts a person at increased risk of suffering from a condition, illness, or injury due to sexual behavior carried out.

Adolescent risk behaviors can be caused by their perception. Regarding the transmission of HIV/AIDS, an individual's perceptions about the risk of HIV infection often influence prevention behaviors such as whether he has an HIV test or uses a condom in sexual activity or does not have unprotected sex. The relationship between perceived risk behavior and the risk of perceived HIV infection is still underappreciated among adolescents [9].

The perception of HIV risk that is still low in adolescents can influence risky sexual behavior. This can be a cause of the spread of HIV infection in adolescents. Adolescents sometimes feel powerless in adopting preventive measures to reduce their health risks. False beliefs will also affect adolescent perceptions about HIV/AIDS risk behavior.

HIV/AIDS transmission prevention behavior is very necessary because the HIV/AIDS epidemic in adolescents in Indonesia is increasing every year. Factors that are significantly related to adolescent behavior towards HIV/AIDS prevention are the level of knowledge and attitudes [10].

The Millennium Development Goals (MDGs) have targeted reducing HIV/AIDS epidemic. In fact at this time the target has not been achieved. Not fully the public knows about HIV/AIDS, including teenagers. Globally, currently adolescents who have comprehensive knowledge about HIV/AIDS only reach 67.3% in adolescent boys and 66% in adolescent girls [11]. This program is continued through Sustainable Development Goals (SDGs). The goal is to achieve the target in ending the AIDS epidemic by 2030. Increasing the knowledge and awareness of the community is still being carried out. Good knowledge will support good attitude. Knowledge about HIV/AIDS can influence students to take warnings and make good choices [12]. Adolescents with positive attitudes show good behavior [13]. Attitudes reflect the level of knowledge of an individual.

This study uses descriptive analytic design to describe the characteristics and perceptions of students in preventing HIV/AIDS risk behavior in Central Java, analyzing differences in perceptions about HIV/AIDS risk behavior between male and female students, different perceptions between students in urban and rural areas.

2 Method

The study population was senior high school students in three regions with the highest rates of HIV/AIDS transmission in Central Java in 2019, that is Jepara, Banyumas and Semarang. The three regions also represent urban and rural areas in the province of Central Java. The total population of this study was 61,749 students. The number of samples is calculated according to the formula for calculating the minimum sample size obtained a sample of 322 students and divided proportionally namely 119 (36.96%) men and 203 (63.04%) women.

The data of this study were collected using a questionnaire consisting of two parts, namely characteristics and perceptions about HIV/AIDS risk behavior. Perception scores are categorized into four categories, very low (score 1.00-1.49), low (score 1.50-2.49), moderate (score 2.50-3.00), high (score 3.01-3.49) and very high perception (score 3.50-4.00). Data analysis was performed with a t-test at a probability level of 0.05 to determine differences in perceptions between male and female students, as well as differences in perceptions between students in urban and rural areas.

3 Result and Discussion

3.1 Perception of HIV/AIDS Risk Behavior among Students in Central Java Indonesia

Table 1. Perception of HIV/AIDS Risk Behavior among Students in Central Java Indonesia

Q	HIV/AIDS Risk Behavior Perception	Mean	SD	Decision
1.	Avoiding sex relations with people who have many partners can prevent the transmission of HIV / AIDS	3.74	0.56	Very high
2.	HIV/AIDS can be treated by a traditional physician	3.54	0.60	Very high
3.	Living with an uninfected partner will help someone avoid HIV/AIDS	3.14	0.72	High
4.	Harmless sex with commercial sex workers	3.60	0.67	Very high
5.	HIV/AIDS can be transmitted through mosquito and flea bites	3.05	0.70	High
6.	Antibiotics can be used to treat HIV/AIDS	2.73	0.66	Moderate
7.	HIV/AIDS can be transmitted through magic	3.54	0.64	Very high
8.	Non-screened blood transfusion can make someone infected with HIV/AIDS	3.35	0.61	High
9.	HIV/AIDS can be transmitted by using the same toilet as a Sufferer	2.69	0.78	Moderate
10.	There is a vaccine to protect yourself from HIV/AIDS	2.40	0.78	Low
11.	Prayers can protect themselves from HIV/AIDS transmission	2.23	0.78	Low
12.	HIV/AIDS is a strategy adopted to reduce sexual activity in people	2.48	0.82	Low
13.	Not having sex can make a person not infected with HIV/AIDS	2.73	0.84	Moderate
14.	HIV/AIDS can be transmitted through sex without condom	3.34	0.66	High
15.	Having many sex partners is not wrong	3.46	0.77	High
16.	Sharing sharp objects (such as razors and needles) can be a risk for HIV/AIDS transmission	2.83	0.81	Moderate
17.	Having sex with a person without a condom will be a high risk of contracting	3.50	0.62	Very high
18.	Kissing with your mouth outside the sexual area cannot transmit HIV/AIDS.	2.51	0.73	Moderate
19.	Hugs can transmit HIV/AIDS	3.14	0.75	High
20.	Using tableware together can transmit HIV/AIDS	2.48	0.83	Low
21.	Having sex with many people with a condom can make a person not infected with HIV/AIDS	1.00	0.00	Very Low
22.	Herbal medicine can cure AIDS	2.82	0.72	Moderate
23.	Oral sex can transmit HIV/AIDS	2.96	0.66	Moderate
24.	Anal sex can transmit HIV/AIDS	3.02	0.66	High
	Total	2.93	0.16	Moderate

The results of the study in table 1 show that from the total score ($M = 2.93$, $SD = 0.16$). This shows that the perception of HIV/AIDS risk behavior among students in Central Java in Indonesia is in the moderate level. The results of this study different from other studies who find that the risk perception among students is high

[14], and other studies found that adolescent perceptions of HIV risk behavior are generally low [15,16].

The findings of this study also mentioned that of the 322 students, 31.99% of students already had a high perception of HIV/AIDS risk behavior, and there were still 1.86% of students who still had low perception. Students in Indonesia do not yet fully have high perceptions about HIV/AIDS risk behavior, one of which is due to the lack of student knowledge about HIV/AIDS. They do not specifically get knowledge of HIV/AIDS through subjects in schools, but they get information about HIV/AIDS through media such as the internet, magazines or counseling that has been followed.

Having sex with many people with a condom can make a person not infected with HIV/AIDS is an example of a perception that many are wrong among teenagers or students in Indonesia. Condoms do not guarantee that they can effectively prevent the transmission of HIV/AIDS, if they are not used correctly and consistently in the changing sexual behavior of partners. In addition, there are still many students who believe that sharing cutlery risks transmitting the HIV virus, as well as many of them stating that the vaccine can to protect themselves from HIV/AIDS.

3.2 Mean Rating of HIV/AIDS Risk Behavior Perceptions in Male and Female Students in Central Java Indonesia

Table 2. Mean Rating of HIV/AIDS Risk Behavior Perceptions in Male and Female Students in Central Java Indonesia

Q	HIV/AIDS Risk Behavior Perception	Males			Females		
		M	S	D	M	S	D
1.	Avoiding sex relations with people who have many partners can prevent the transmission of HIV / AIDS	3.68	0.62	Very high	3.77	0.52	Very high
2.	HIV/AIDS can be treated by a traditional physician	3.58	0.64	Very high	3.51	0.57	Very high
3.	Living with an uninfected partner will help someone avoid HIV/AIDS	3.24	0.74	High	3.08	0.71	High
4.	Harmless sex with commercial sex workers	3.53	0.76	Very high	3.64	0.62	Very high
5.	HIV/AIDS can be transmitted through mosquito and flea bites	3.03	0.75	High	3.05	0.68	High
6.	Antibiotics can be used to treat HIV/AIDS	2.85	0.67	Moderate	2.66	0.64	Moderate
7.	HIV/AIDS can be transmitted through magic	3.62	0.64	Very high	3.49	0.63	High
8.	Non-screened blood transfusion can make someone infected with HIV/AIDS	3.32	0.66	High	3.37	0.59	High
9.	HIV/AIDS can be transmitted by using the same toilet as a Sufferer	2.76	0.77	Moderate	2.64	0.79	Moderate
10.	There is a vaccine to protect yourself from HIV/AIDS	2.60	0.82	Moderate	2.29	0.74	Low
11.	Prayers can protect themselves from HIV / AIDS transmission	2.13	0.87	Low	2.29	0.72	Low
12.	HIV/AIDS is a strategy adopted to reduce sexual activity in people	2.45	0.92	Low	2.49	0.76	Low
13.	Not having sex can make a person not	2.80	0.94	Mod-	2.69	0.79	Moder-

	infected with HIV/AIDS			erate		ate
14.	HIV/AIDS can be transmitted through sex without condom	3.42	0.71	High	3.29	High
15.	Having many sex partners is not wrong	3.29	0.86	High	3.57	Very high
16.	Sharing sharp objects (such as razors and needles) can be a risk for HIV/AIDS transmission	2.81	0.92	Moderate	2.85	Moderate
17.	Having sex with a person without a condom will be a high risk of contracting	3.58	0.59	Very high	3.46	High
18.	Kissing with your mouth outside the sexual area cannot transmit HIV/AIDS.	2.49	0.79	Low	2.53	Moderate
19.	Hugs can transmit HIV/AIDS	3.18	0.78	High	3.11	High
20.	Using tableware together can transmit HIV/AIDS	2.60	0.86	Moderate	2.42	Low
21.	Having sex with many people with a condom can make a person not infected with HIV/AIDS	1.00	0.00	Very low	1.00	Very low
22.	Herbal medicine can cure AIDS	2.89	0.73	Moderate	2.78	Moderate
23.	Oral sex can transmit HIV/AIDS	2.90	0.73	Moderate	3.00	Moderate
24.	Anal sex can transmit HIV/AIDS	2.96	0.81	Moderate	3.05	High
	Total	2.95	0.18	Moderate	2.92	Moderate

Table 2 shows that from the total score it was found that in male students ($M=2.95$, $SD=0.18$) and in female students ($M=2.92$, $SD=0.16$). This indicates that both male and female student groups in Central Java in Indonesia have perceptions of HIV/AIDS risk behavior in the moderate levels.

Table 3. Comparison of mean rating of HIV/AIDS risky behavior perceptions in male and female students

Gender	N	Mean	SD	T	Df	Sig (2-tailed)	95% CI
Male	119	2.94	0.24	1.16	320	0.265	-0.022 - 0.081
Female	203	2.91	0.21				

Table 3 shows that from the T-test analysis, p values ($p=0.265$) is greater than 0.05 level of significance. This means that there is no significant difference between perceptions of HIV/AIDS risk behavior between male and female students in Central Java Indonesia, $t(320) = 1.16$, $p = 0.265$. The results of this study support the research of Bernedeth N. Ezege et al, which states there is no significant difference between the average level of perception about the risk of HIV / AIDS in male and female students in secondary schools [17].

But the results of this study contradict Kibombo, et al, who found that there were significant differences in perceptions of HIV/AIDS risk behaviors between men and women [16]. Other studies by Bhasin, who revealed that there were significant differences between men and women in the perception of the risk of HIV infection. Women have more positive perceptions about HIV/AIDS risk behavior compared to men [18].

Likewise, Steinberg and Monahan's, study found that gender factors greatly influenced a person's risk behaviors and women were found to be more receive to the effects of these risk behaviors than men [19].

3.3 Mean Rating of HIV/AIDS Risk Behavior Perceptions in Urban and Rural Students in Central Java Indonesia

Table 4. Mean Rating of HIV/AIDS Risk Behavior Perceptions in Urban and Rural Students in Central Java Indonesia

Q	HIV/AIDS Risk Behavior Perception	Urban			Rural		
		M	S	D	M	S	D
1.	Avoiding sex relations with people who have many partners can prevent the transmission of HIV / AIDS	3.72	0.58	Very high	3.76	0.54	Very high
2.	HIV/AIDS can be treated by a traditional physician	3.58	0.59	Very high	3.49	0.60	High
3.	Living with an uninfected partner will help someone avoid HIV/AIDS	3.19	0.70	High	3.08	0.75	High
4.	Harmless sex with commercial sex workers	3.57	0.72	Very high	3.63	0.61	Very high
5.	HIV/AIDS can be transmitted through mosquito and flea bites	3.12	0.72	High	2.96	0.67	Moderate
6.	Antibiotics can be used to treat HIV/AIDS	2.81	0.67	Moderate	2.62	0.64	Moderate
7.	HIV/AIDS can be transmitted through magic	3.61	0.58	Very high	3.45	0.69	High
8.	Non-screened blood transfusion can make someone infected with HIV/AIDS	3.37	0.63	High	3.32	0.60	High
9.	HIV/AIDS can be transmitted by using the same toilet as a Sufferer	2.77	0.76	Moderate	2.58	0.79	Moderate
10.	There is a vaccine to protect yourself from HIV/AIDS	2.45	0.78	Low	2.35	0.79	Low
11.	Prayers can protect themselves from HIV / AIDS transmission	2.26	0.83	Low	2.20	0.71	Low
12.	HIV/AIDS is a strategy adopted to reduce sexual activity in people	2.48	0.84	Low	2.47	0.80	Low
13.	Not having sex can make a person not infected with HIV/AIDS	2.75	0.85	Moderate	2.71	0.84	Moderate
14.	HIV/AIDS can be transmitted through sex without condom	3.39	0.66	High	3.26	0.66	High
15.	Having many sex partners is not wrong	3.43	0.78	High	3.50	0.74	Very high
16.	Sharing sharp objects (such as razors and needles) can be a risk for HIV/AIDS transmission	2.84	0.82	Moderate	2.82	0.80	Moderate
17.	Having sex with a person without a condom will be a high risk of contracting	3.52	0.60	Very high	3.48	0.64	High
18.	Kissing with your mouth outside the sexual area cannot transmit HIV/AIDS.	2.49	0.77	Low	2.54	0.68	Moderate
19.	Hugs can transmit HIV/AIDS	3.29	0.70	High	2.94	0.78	Moderate
20.	Using tableware together can transmit HIV/AIDS	2.57	0.85	Moderate	2.37	0.80	Low

21.	Having sex with many people with a condom can make a person not infected with HIV/AIDS	1.00	0.00	Very low	1.00	0.00	Very low
22.	Herbal medicine can cure AIDS	2.87	0.69	Moderate	2.75	0.75	Moderate
23.	Oral sex can transmit HIV/AIDS	2.97	0.66	Moderate	2.94	0.66	Moderate
24.	Anal sex can transmit HIV/AIDS	3.02	0.69	High	3.01	0.62	High
	Total	2.96	0.17	Moderate	2.88	0.16	Moderate

Based on the total score in table 4, it is known that the students who live in urban areas ($M= 2.96$, $SD= 0.17$) and students who live in rural areas ($M= 2.88$, $SD= 0.16$). This indicates that students from urban and rural areas have a moderate perception of HIV/AIDS risk behavior.

Table 5. Comparison of mean rating of HIV/AIDS risky behavior perceptions in rural and urban students

Location	N	Mean	SD	T	Df	Sig (2-tailed)	95% CI
Urban	180	2.96	0.22	3.04	320	0.003	0.027 - 0.126
Rural	142	2.88	0.22				

Table 5 shows that from the T-test analysis, p values ($p= 0.003$) is less than 0.05 level of significance. This means that there is a significant difference between perceptions of HIV/AIDS risk behavior between students living in urban areas and students living in rural areas in Central Java Indonesia, $t(320) = 3.04$, $p = 0.003$. This study found that students who live in urban areas tend to have a better perception than students who live in rural areas.

The results of this study contradict Danjin and Onajole, who found that there were no significant differences between levels of awareness about HIV/AIDS among respondents in urban and rural areas [20]. But on the contrary, the results of this study support the opinion of Vaghela, which states urban teenagers have higher perceptions about HIV/AIDS risk behavior than rural teenagers [21]. This study also supports Bernedeth N. Ezegbe et al, who found a significant difference in the average ranking of perceptions of HIV/AIDS risk among urban and rural secondary school adolescents [17].

4 Conclusion

The results of this study conclude that the perception of HIV/AIDS risk behavior among students in Central Java in Indonesia is at a moderate level. There is no significant difference between the level of perception about HIV/AIDS risk behavior between male and female students in Central Java, Indonesia. Both tendencies have a moderate level of perception. However it was found, there was a significant difference in the average rank of adolescents in urban and rural areas in schools with regard

to their perceptions about HIV/AIDS risk behavior. Students in urban areas have better perceptions than students in rural areas.

Further studies can be carried out using a larger population to support the urgency of counseling programs according to the needs of students in senior high school about HIV/AIDS risk behavior. Further research can also be focused on factors that influence adolescent perceptions of risks that make them vulnerable to HIV/AIDS.

References

- [1]. Director General of P2PL, Ministry of Health. Statistics on HIV / AIDS Cases in Indonesia Trimester IV of 2018. Jakarta: Ministry of Health of the Republic of Indonesia; 2018
- [2]. Central Java AIDS Commission. HIV / AIDS data in Central Java. Semarang: KPA Central Java; 2019
- [3]. UNICEF. Every three minutes a teenage girl is infected by HIV. Retrieved from <https://www.unicef.org/wca/press-releases/every-three-minutes-teenage-girl-infected-hiv-unicef>; 2018.
- [4]. Smriti N., & Marfatia, Y. S. Adolescent HIV/AIDS: (Issues and challenges). *Indian Journal of Sexually Transmitted Diseases*, 2010; 31(1), 1-29. <https://doi.org/10.4103/0253-7184.68993>.
- [5]. Gupta, R. Gender, Sexuality, and HIV/AIDS: the what, the why, and the how. Plenary Address for the 13th International AIDS Conference, Durban, South Africa; 2000.
- [6]. Vaghela, K. J. A Study of Awareness of HIV/AIDS among Adolescents: (Girls and Boys of Urban and Rural Area). *The International Journal of Indian Psychology*, 2015; 3, 886.
- [7]. Centers for Disease Control and Prevention. HIV Risk Behaviors. Retrieved from <https://www.cdc.gov/hiv/risk/estimates/riskbehaviors.html>; December 4, 2015.
- [8]. Zwar, N. A., Mendelsohn, C. P., & Richmond, R. L. Supporting smoking cessation. *BMJ*, 2014; 348, f7535. <https://doi.org/10.1136/bmj.f7535>
- [9]. Akwara P. A., Madise, N. J., & Hinde, A. Perception of Risk of HIV/AIDS And Sexual Behaviour In Kenya. *Journal of Biosocial Science*, 2003; 35(3), 385-411. <https://doi.org/10.1017/S0021932003003857>
- [10]. Nugrahawati et al. 2019. Factors Related to Adolescent Behavior in HIV/AIDS Prevention. *Kesmas: National Public Health Journal*, 2019; 13 (4): 195-201 DOI:10.21109/kesmas.v13i4.2698
- [11]. Stalker P. Millennium development goals; 2008. p. 7
- [12]. Setyarini AI, Titisari I, Ramadhania PA. Hubungan pengetahuan remaja tentang HIV/AIDS dengan sikap pencegahan HIV/AIDS di SMA Negeri1 Gurah Kabupaten Kediri. *Jurnal Ilmu Kesehatan*. 2016; 4 (2); 25-33
- [13]. Aung Z, Anisah, Wee KW, Kyin H, Than N, Kamil, et al. Cross sectional study of knowledge, attitude, and practice on HIV infection among secondary school students in Kuala Terengganu. *International Journal of Medicine and Medical Sciences*. 2013; 4 (4); 1335-1346.
- [14]. Adogu, P., Udigwe, I., Nwabueze, A., Adinma, E., Udigwe, G., & Onwasigwe, C. (2015). Sexual health knowledge, attitude and risk perception among in-school and out-of-school female adolescents in Onitsha, Anambra State, Nigeria. *South Eastern European Journal of Public Health*, 2(1).
- [15]. Darteh, E. K., Kumi-Kyereme, A., & Awusabo-Asare, K. (2016). Perception of Risk of HIV among Adolescents' Living in an Urban Slum in Ghana. *African Journal of Reproductive Health*, 20(1), 62-70
- [16]. Kibombo, R., Neema, S., & Ahmed, F. H. (2007). Perceptions of risk to HIV infection among adolescents in Uganda: are they related to sexual behaviour?. *African Journal of Reproductive Health*, 11(3), 168. <https://doi.org/10.2307/25549738>

- [17]. Bernedeth N. Ezegbe et al. Perception of Risk Behaviours Influencing HIV and AIDS Prevention and Control among Secondary School Adolescents in Enugu State, Nigeria. *Global Journal of Health Science*, 2019, 11 (6).
- [18]. Bhasin, S., Storer, T. W., Berman, N., Callegari, C., Clevenger, B., Phillips, J., ... & Casaburi, R. (1996). The effects of supraphysiologic doses of testosterone on muscle size and strength in normal men. *New England Journal of Medicine*, 335(1), 1-7. <https://doi.org/10.1056/NEJM199607043350101>
- [19]. Steinberg, L., & Monahan, K. C. (2007). Age differences in resistance to peer influence. *Developmental Psychology*, 43(6), 1531. <https://doi.org/10.1037/0012-1649.43.6.1531>
- [20]. Danjin, M., & Onajole, A. (2009). HIV/AIDS Risk Behavioural Tendencies Among Secondary School Students in Gombe (Nigeria). *The Internet Journal of Health*, 11(1).
- [21]. Vaghela, K. J. (2015). A Study of Awareness of HIV/AIDS among Adolescents: (Girls and Boys of Urban and Rural Area). *The International Journal of Indian Psychology*, 3, 886

Feeding Pattern of Under-Five Children during COVID-19 Pandemic

Mursid Tri Susilo¹, Arif Rahmat Kurnia², Fitriyatun Na'imah³, Muhammad Fadlil Fatihunnajah⁴, Annisa Wahyu Hidayah⁵
 {mursid_ts@yahoo.co.id¹, arifrahmatk@gmail.com², fitriyatunnaimah@gmail.com³}

Universitas Negeri Semarang, Semarang, Indonesia^{1,2,3,4,5}

Abstract. The world was shocked by Covid-19 (Coronavirus Diseases-19) pandemic at the end of 2019. The virus attacked the average person aged 49 years, while few cases were found in under-five children. Despite the fact that under-five can still be infected by Covid-19. It was very important for under-five to get foods rich of nutrients to boost immune system in preventing Covid-19 infection. The pandemic threatens normal life, forcing parents and caregivers to adapt in term of feeding pattern. This study aims to obtain a clearer description related to feeding pattern in under-five children before and during Covid-19 pandemic. A cross-sectional design was used in this study. Online questionnaires were distributed among mothers or caregivers of under-five children across provinces in Indonesia. Statistical data were analyzed by *Mc Nemar test*. There were no significant differences between feeding pattern before and during the Covid-19 pandemic ($p > 0.05$).

Keywords: Covid-19, feeding pattern, nutrition, under-five children

1 Introduction

An unexpected pandemic appeared in late of 2019 in Wuhan City, Hubei Province, China. The virus caused pneumonia-like symptoms along with unclear etiology [1], the case spread rapidly and was identified as a new type of coronavirus [2]. World Health Organization (WHO) confirmed a new name of this new strain of virus as Coronavirus Disease-19 (Covid-19). Several symptoms occurred such fever, cough, myalgia or fatigue [3].

The virus attacked persons average of 49 years old with age range 16 to 76 years old [3], while fewer cases were found in children [4]. Even so, the prevalence of Covid-19 infections in children might be able to increase in the future, a small number at the outset did not mean they were not susceptible to infection. In fact, children especially under-five could still be infected by Covid-19 [4]. Preliminary evidence suggests children were just as likely as adults to become infected with Covid-19 but were less likely to be symptomatic or develop severe symptoms. However, the importance of children in transmitting the virus remains unclear. Children more often had gastrointestinal symptoms compared to adults [5]

It was very important for under-five children to get foods rich of nutrients to boost their immune system, capture growth and development. The pandemic caused by Covid-19 threatens normal life therefore parents or caregivers might not be able to leave the house just to get groceries or ready-to-eat foods normally for their children. This phenomenon forced parents and caregivers to adapt in feeding their children. They might order online food more often than go to grocery store or market for shopping. The Covid-19 pandemic has led to a sharp increase in online trade [6]. Accordingly, it was necessary to identify parent adaptation regarding children feeding pattern in term of fullfilling nutritional requirement during Covid-19 pandemic. Such information would be valuable so that appropriate recommendations could be taken to support nutritional achievement of the children.

2 Materials and Methods

Design of the study was cross-sectional. It used consecutive sampling to recruit respondents, they were mothers or care givers who take care of under-five children among several islands in Indonesia. Sample size was determined by slovin formula. Online questionnaires were distributed among respondent contains of subject characteristics informations, food pattern before and during Covid-19 pandemic. Data were analyzed by *Statistical Package for the Social Sciences (SPSS) software* using *Mc-Nemar test*.

3 Results and Discussions

3.1 Subject Characteristics

There were 83 respondents participated in this study, 78 respondents filled out the online questionnaire completely while 5 of them were incomplete. Subject characteristics were described in Table 1. Subjects were collected from Java, Sumatra, Kalimantan and Sulawesi islands. The average family income before Covid-19 pandemic was 3.000.000 – 3.999.999 IDR meanwhile declined to 2.000.000 – 2.999.999 IDR during pandemic.

Most of father had undergraduate or higher education 48 subjects (61.5%), it showed that they were well educated. This fact also occurred in mothers who are equally well educated. It was common for fathers to work in private sectors. However, there was an issue to be unemployed especially private employee who changed to be unemployed or farmer or trader. It was indicated by an increase in the number of unemployed father who initially all of them worked before the pandemic, but increased to 6 people who were unemployed (7.7%). Meanwhile, there was not much change in mothers occupation before and during pandemic. Most of mothers worked as housewives, private employees or government employees. Majority of mothers had normal nutritional status, however there were still mothers with underweight, overweight or even obesity.

Children data were collected from the mothers or care givers information. The median age of children was 19.00 (min 0; max 59) months old. Children age category was divided into three groups. There were 12 (15.4 %) children were less than six

months old, 38 (48.7 %) children were 6-23 months old, whereas 28 (35.9 %) children were 24-59 months old. Unexpectedly, gender distribution among children were evenly distributed as many as 39 (50%) children were male and female with the exact same number. Children got consistent frequency of breastfeeding between before and during the covid-19 pandemic.

More than half of children 43 (55.1%) still got breast milk from their mother among 78 subjects. Almost all of children 39 (90.7%) did not experience a change in the frequency of breastfeeding, only a small proportion decreased (7%) or even increased (2.3%) from before the pandemic occurred until it took place. The average frequency of breastfeeding was 7-8 times a day before and during pandemic.

Table 1. Subject characteristics

Variable	Category	Frequency	Percent (%)
Residence	Java	66	84.6
	Sumatra	7	9.0
	Kalimantan	2	2.6
	Sulawesi	3	3.8
Family income before and during Pandemic	Decline	44	56.4
	Consistent	34	43.6
Father Education	Primary school	5	6.4
	Junior high school	1	1.3
	Senior high school	20	25.6
	Diploma	4	5.1
	Undergraduate or higher	48	61.5
Father Occupation before pandemic	Farmer	2	2.6
	Trader	7	9.0
	Government employee	9	11.5
	Private employee	47	60.3
	Others	13	16.7
Father Occupation During pandemic	Farmer	3	3.8
	Trader	8	10.3
	Government employee	9	11.5
	Private employee	41	52.6
	Unemployed	6	7.7
Mother Education	Others	11	14.1
	Elementary school	1	1.3
	Junior high school	2	2.6
	Senior high school	11	14.1
	Diploma	10	12.8
Mother Occupation before pandemic	Undergraduate or higher	54	69.2
	Farmer	1	1.3
	Trader	5	6.4
	Government employee	12	15.4
	Private employee	28	35.9
Mother Occupation during pandemic	Housewife	29	37.2
	Others	3	3.8
	Farmer	1	1.3
	Trader	6	7.7

	Government employee	12	15.4
	Private employee	28	35.9
	Housewife	29	37.2
	Others	2	2.6
Nutritional status of mother during pandemic	Underweight	10	13.0
	Normal	43	55.8
	Overweight	12	15.6
	Obese	12	15.6
Gender of under-five children	Male	39	50.0
	Female	39	50.0
Age of children	less than 6 months old	12	15.4
	6 – 23 months old	38	48.7
	24 – 59 months old	28	35.9
Breastfeeding Frequecy	Decline	3	7.0
	Consistent	39	90.7
	Increase	1	2.3

3.2 Bivariate Analysis

Comparison of exclusive breastfeeding before and during Covid-19 on infants ≤ 6 months old was described in Table 2.

Table 2. Comparison of exclusive breastfeeding before and during pandemic on infants ≤ 6 months old

		During Pandemic		Total	p-value
		Non Exclusive Breastfeeding	Exclusive Breast-feeding		
Before Pandemic	Non Exclusive Breastfeeding	4 (33.3)	0 (0.0)	4 (33.3)	0.500*
	Exclusive Breast-feeding	2 (16.7)	6 (50.0)	8 (66.7)	
Total		6 (50.0)	6 (50.0)	12 (100.0)	

*Mc Nemar test

Proportion of exclusive breastfeeding before pandemic was 66.7% whereas 50.0% during pandemic. It was happened because because the possibility of the infant entered the weaning period and exceeded the age of 6 months so that there was a change in the status of exclusive breastfeeding to be non exclusive breastfeeding. However, there was no difference in exclusive breastfeeding practice before and during pandemic according to statistics data analysis ($p > 0.05$). Recommendation to keep exclusive breastfeeding for infants's first 6 months of life was explained by *The American Academy of Pediatrics*. Researchs stated that exclusive breastfeeding through 6 months had greater protection against gastrointestinal infection and also respiratory tract infection [7].

Comparison of breastfeeding difficulties before and during pandemic on children less than two years old was described in Table 3.

Table 3. Comparison of breastfeeding before and during pandemic on children less than two years old

		During Pandemic		Total	p-value
		Did not experience difficulties	Experience difficulties		
Before Pandemic	Did not experience difficulties	38 (80.9)	2 (4.3)	40 (85.1)	0.500*
	Experience difficulties	0 (0.0)	7 (14.9)		
Total		38 (80.9)	9 (19.1)	47 (100.0)	

*Mc Nemar test

Majority of mothers did not experienced difficulties in breastfeed their children (80.9%) before and during pandemic (85.1%). It might related to the occupational status of mothers, who were mostly housewives and had not changed from before the pandemic and when the pandemic occurred. This finding was inline with the research stated that government employee mothers, the odds of breastfeeding were reduced by half compared to housewives (AOR 0.49, 95% CI 0.26, 0.94)[8]. It can be understood that housewives had a lot of time and focus given to the children, so that the opportunity for children to be breastfed was greater than mothers who were busy working. Research in developing country showed that mothers had high levels of knowledge about exclusive breastfeeding, but low adherence. Mothers faced barriers to exclusive breastfeeding due to the need to return to work outside the home [9]. In line with research in Canada, family also had an important role for breastfeeding practice. Fathers influence mothers' breastfeeding decisions and experiences. The main fathering role was that of supporting breastfeeding by using their knowledge to encourage and assist mothers in breastfeeding, by valuing the breastfeeding mothers, and by sharing housework and child care [10].

Behaviour during breastfeeding were described in Table 4 and Table 5.

Table 4. Behaviour of mothers to breastfeed with both breasts

		During Pandemic		Total	p-value
		No	Yes		
Before Pandemic	No	4 (9.1)	0 (0.0)	4 (9.1)	1.000*
	Yes	0 (0.0)	40 (90.9)		
Total		4 (9.1)	40 (90.9)	44 (100.0)	

*Mc Nemar test

Proportion of mothers who breastfeed with both breasts was 90.9% before pandemic and also during pandemic. Almost all of mothers keep practising breastfeed, it indicated that good behavior will be difficult to disappear even in difficult circumstances such as the Covid-19 pandemic. Standard measurement of the breastfeeding sufficiency was complicated by factors related to definitions, timing, duration of recall, or methods of analysis [11]. However, breastfeeding practice using both breasts showed mothers effort to give her breast milk as much as possible to their children. It was necessary to nurse from each breast at every feeding so both get adequate stimulation and drainage. Therefore, Furthermore, children take more milk when they nurse on both sides. But, how to know when to switch, the best way to know is when the rhythmic sucking and swallowing slows down, or the baby releases the breast. That indicates that the rate of milk flow is diminishing and it is time to move to the other side. Remove baby by inserting a finger in his mouth to release the suction, burp him, then offer the other breast and try alternating the first breast at each feeding [12].

Table 5. Behaviour of mothers to breastfeed until felt empty breasts

		During Pandemic			p-value
		No	Yes	Total	
Before Pandemic	No	10 (22.7)	0 (0.0)	10 (22.7)	1.000*
	Yes	0 (0.0)	34 (77.3)	34 (77.3)	
Total		10 (22.7)	34 (77.3)	44 (100.0)	

*Mc
Nemar test

Proportion of mothers who breastfeed until felt empty breasts was 77.3% before pandemic and also during pandemic, meanwhile behaviour to stop breastfeed before felt empty breast was still prevalent (22.7%). Perception of the mothers about empty breast was important. Mothers who felt that their breast milk was sufficient after several breastfeeding practise, meanwhile in fact that breasts were not empty enough, it possible for the children would lack a lot of nutrients than they should.

Food availability in the family for a day was described in Table 6.

Table 6. Food availability in the family for a day

		During Pandemic			p-value
		No food available	Food available	Total	
Before Pandemic	No food available	0 (0.0)	0 (0.0)	0 (0.0)	0.063*
	Food available	5 (6.41)	73 (93.59)	78 (100.0)	
Total		5 (6.41)	73 (93.59)	78 (100.0)	

*Mc Nemar test

Food were available among children, it might be because of the family had sufficient income. Generally, fathers were well educated, therefore the private sectors where they work might provide a good job positions to get an adequate income for family needs. In accordance with researchs stated that high levels of educational attainment were also associated with higher income [13]. Reviews argued that nutrition was an integral component of food security, and should be embedded within all four of its dimensions – availability, access, utilization, and stability. Obstacles in food availability in the Middle East and North Africa (MENA) region, as exacerbated by the triple burden of malnutrition, where undernutrition, micronutrient deficiencies, and overweight/obesity coexist [14]. A result from another research explained that that socioeconomic status (SES) at both individual (education, income) and neighborhood level was linked to home food availability, suggesting a need to improve the home food environment for socioeconomically disadvantaged individuals and neighborhoods [15].

4 Conclusion

Finally, it can be stated several conclusions that can be obtained from this study. Feeding pattern were not changed since before and during Covid-19 pandemic spread out. They were exclusive breast feeding practice, difficulties in breastfeeding, behaviour of using both breasts while giving breast milk to the children, behaviour of mothers to breastfeed until felt empty breasts and food availability among family.

References

- [1]. C. Sohrabi et al., “World Health Organization declares global emergency: A review of the 2019 novel coronavirus (COVID-19),” *Int. J. Surg.*, vol. 76, no. February, pp. 71–76, 2020.
- [2]. Q. Li et al., “Early transmission dynamics in Wuhan, China, of novel coronavirus-infected pneumonia,” *N. Engl. J. Med.*, vol. 382, no. 13, pp. 1199–1207, 2020.
- [3]. F. Song et al., “Emerging 2019 novel coronavirus (2019-NCoV) pneumonia,” *Radiology*, vol. 295, no. 1, pp. 210–217, 2020.
- [4]. M. Wei, J. Yuan, Y. Liu, T. Fu, X. Yu, and Z.-J. Zhang, “Novel Coronavirus Infection in Hospitalized Infants Under 1 Year of Age in China,” *Jama-Journal Am. Med. Assoc.*, pp. E1–E2, 2020.
- [5]. P. Zimmermann and N. Curtis, “Coronavirus infections in children including COVID-19: An overview of the epidemiology, clinical features, diagnosis, treatment and prevention options in children,” *Pediatr. Infect. Dis. J.*, vol. 39, no. 5, pp. 355–368, 2020.
- [6]. P. Dannenberg, M. Fuchs, T. Riedler, and C. Wiedemann, “Digital Transition by COVID-19 Pandemic? The German Food Online Retail,” *Tijdschr. voor Econ. en Soc. Geogr.*, vol. 111, no. 3, pp. 543–560, 2020.
- [7]. C. J. Chantry, C. R. Howard, and P. Auinger, “Full breastfeeding duration and associated decrease in respiratory tract infection in US children,” *Pediatrics*, vol. 117, no. 2, pp. 425–432, 2006.

- [8]. M. T. Hunegnaw, L. D. Gezie, and A. S. Teferra, "Exclusive breastfeeding and associated factors among mothers in Gozamin district, northwest Ethiopia: A community based cross-sectional study," *Int. Breastfeed. J.*, vol. 12, no. 1, pp. 1–8, 2017.
- [9]. M. M. Thet, E. E. Khaing, N. Diamond-Smith, M. Sudhinaraset, S. Oo, and T. Aung, "Barriers to exclusive breastfeeding in the Ayeyarwaddy Region in Myanmar: Qualitative findings from mothers, grandmothers, and husbands," *Appetite*, vol. 96, pp. 62–69, 2016.
- [10]. L. A. Rempel and J. K. Rempel, "The breastfeeding team: The role of involved fathers in the breastfeeding family," *J. Hum. Lact.*, vol. 27, no. 2, pp. 115–121, 2011.
- [11]. T. Greiner, "Exclusive breastfeeding: measurement and indicators," *Int. Breastfeed. J.*, vol. 9, no. 1, pp. 1–6, 2014.
- [12]. A. Nadeem, J. Nadeem, M. H. Sarwar, and M. Sarwar, "Making the Decision to Breastfeed the Baby and Its Advantages for the Women ' s Health," *Am. J. Food Sci. Heal.*, vol. 3, no. 5, pp. 88–94, 2017.
- [13]. A. Rodríguez-Pose and V. Tselios, "Education and income inequality in the regions of the European Union," *J. Reg. Sci.*, vol. 49, no. 3, pp. 411–437, 2009.
- [14]. N. Hwalla, S. El Labban, and R. A. Bahn, "Nutrition security is an integral component of food security," *Front. Life Sci.*, vol. 9, no. 3, pp. 167–172, 2016.
- [15]. W. Chai, J. X. Fan, and M. Wen, "Association of Individual and Neighborhood Factors with Home Food Availability: Evidence from the National Health and Nutrition Examination Survey," *J. Acad. Nutr. Diet.*, vol. 118, no. 5, pp. 815–823, 2018.

Effect of Demographic, Social and Economic Factors on Adolescent Dating and Sexual Behavior in Indonesia

Najib¹, Efa Nugroho²
 {jibpenkb@gmail.com¹, efa.nugroho@mail.unnes.ac.id²}

National Population and Family Planning Board (BKKBN) of Central Java, Semarang, Indonesia¹
 Universitas Negeri Semarang, Semarang, Indonesia²

Abstract. In the 2017 IDHS, 8% of men and 2% of women reported having had sexual relations, with reasons including: 47% love each other, 30% are curious / curious, 16% just happens, each 3% percent due to being forced and influenced by friends. Among women and men who have had sexual relations pre-marital, 59% of women and 74% of men report having first sexual intercourse at the age of 15-19. The highest percentage occurred at the age of 17 years (19%), both men and women. Other findings are 45% percent of women and 44% of men start dating at the age of 15-17. Most women and men confess that when they are dating, they hold hands (64% women and 75% men), cuddle (17% women and 33% men), kiss the lips (30% women and 50% men) and touch / touch (5% women and 22% men).

Keywords: Adolescent, Sexual Behaviour, Dating

1 Introduction

According to the World Health Organization (WHO) about one fifth of the world's population are teenagers 10-19 years old and around 900 million are in developing countries. In addition, demographic data in the United States shows the number of adolescents 10-19 years is around 15% of the population. In Asia Pacific the population is 60% of the world population, one fifth of which are teenagers aged 10-19 years. Based on a report from the Central Statistics Agency, the results of the Population Census show that Indonesia's population is 237.6 million and 63.4 million are teenagers, consisting of men at 50.70% and women at 49.30%. [1,2]

Adolescence is a period of transition, that is someone who is renewed transition from children to adulthood. In adolescence there are several processes of change, physical changes, and psychological changes. The development of the physical body is characterized by more mature organs including the reproductive organs. While this psychological development arises in the development of personal maturity and independence. This distinctive feature of psychological maturity is characterized by an interest in the opposite sex which usually appears in the form of for example more

fun hanging out with the opposite sex and arriving at a relationship that has become increasingly common at this time, namely dating.[3]

Dating for some teenagers is no stranger. In fact, many adolescents have the notion that if adolescence is a period of dating, so adolescents who are not dating are actually considered as old-fashioned, old-fashioned adolescents, do not keep up with the times and are considered to be clumsy or lacking promiscuity. Healthy dating itself is often interpreted as a courtship process in which physical conditions, in essence, are prohibited from contact in acts of physical violence, not physical contact that can affect risky sexual behavior. As a result, sexual behavior often occurs outside of marriage, the impact of sex, especially on adolescents, namely the physical hazards that occur occur exposed to the dangers of early pregnancy, sexually transmitted infections, HIV and AIDS. Sexually transmitted infections (STIs) are diseases that can be transmitted from one person to another through sexual contact.[3]

The main findings of the 2017 Indonesian Demographic Health Survey component of Adolescent Reproductive Health (SDKI 2017 - KRR), shows that nationally there has been an increase in the number of adolescents who had had premarital sexual relations compared to the 2012 IDHS results. In the 2017 IDHS, 8% of men and 2% of women reported having had sexual relations, with reasons including: 47% love each other, 30% are curious / curious, 16% just happens, each 3% percent due to being forced and influenced by friends. Among women and men who have had pre-marital sexual relations, 59% of women and 74% of men report starting sexual intercourse for the first time at the age of 15-19. The highest percentage occurred at the age of 17 years (19%), both men and women.[4]

Other findings are 45% percent of women and 44% of men start dating at the age of 15-17. Most women and men confess that when they are dating they hold hands (64% women and 75% men), cuddle (17% women and 33% men) , kiss the lips (30% women and 50% men) and touch / touch (5% women and 22% men).[5]

The Population, Family Planning and Family Development Program (SKAP) Performance and Accountability Survey is an annual survey that aims to measure the achievement of indicators and strategic objectives of the Population, Family Planning and Family Development (KKBPK) program.[5]

Further analysis of secondary data is an effort to utilize national scale survey data (SKAP) to obtain information on the implementation of the Population, Family Planning and Family Development Program (KKBPK). It is hoped that the results of further analysis can contribute to policy makers, managers and implementers of population programs in making policies and developing population programs more precisely and efficiently.

2 Method

2.1 Research Design

The data used in this study are. This study uses a cross-sectional design to analyze the influence of demographic, economic, and social factors on dating behavior and adolescent sexual experiences in Indonesia.

2.2 Population & Research Samples

The population is teenagers in Indonesia. Sample inclusion criteria are teen respondents who answered the questionnaire in full. All samples that meet the criteria will be included in the data analysis process.

2.3 Data collection

Research data collection begins with the submission of proposals to request the necessary data. Data compilation, analysis, compilation of articles and reports were conducted from May 2020 to December 2020 at Semarang State University.

Data sources are raw data obtained from SKAP in 2017, 2018 and 2019 conducted by BKKBN.

2.4 Research variable

The research variables consisted of Demographic, Social, Economic, Dating Behavior and Teenage Sexual Experiences in Indonesia based on SKAP data for 2017, 2018 and 2019.

2.5 Data analysis

Data analysis consisted of Univariate analysis, Bivariate Analysis, and Multivariate Analysis. Univariate analysis is used to determine the distribution of demographic, social, economic, dating behavior, and sexual behavior data and illustrates the trend patterns from 2017, 2018, and 2019. Bivariate and multivariate analysis is used to determine the effect between variables.

3 Result and Discussion

Adolescence is a period of transition, in which someone experiences a transition from children to adulthood. In adolescence there are several processes of change, including physical changes, and psychological changes. Physical development is characterized by more mature organs including the reproductive organs. While psychologically this development appears in the development of personal maturity and independence. This distinctive feature of psychological maturity is characterized by an interest in the opposite sex which usually appears in the form of for example, preferring to hang out with the opposite sex and arrive at behaviors that have become increasingly common at this time, namely dating.[3]

Dating for some teenagers is no stranger. In fact, many adolescents have the notion that if adolescence is a period of dating, so adolescents who are not dating are actually considered as old-fashioned, old-fashioned adolescents, do not keep up with the times and are considered to be clumsy or lacking promiscuity.[6]

Healthy dating itself is often interpreted as a courtship process in which physical conditions, in essence, are prohibited from contact in acts of physical violence, not physical contact that can affect risky sexual behavior. As a result, sexual behavior

often occurs outside of marriage, the impact of sex, especially on adolescents, namely the physical hazards that occur occur exposed to the dangers of early pregnancy, sexually transmitted infections, HIV and AIDS. Sexually transmitted infections (STIs) are diseases that can be transmitted from one person to another through sexual contact.[7]

Based on a reproductive health survey conducted by the National Population and Family Planning Agency (BKKBN), around 92% of adolescents who are dating, holding hands, there are 82% who kiss each other, and 63% of adolescents who are dating are not ashamed to feel each other (petting) body parts their lovers who should be taboo to do. There are differences in the style of adolescent dating now with the past. Today's teens are more permissive to do anything to show their partner's seriousness. All activities that ultimately affect the intention to have sex further.[8,9]

According to Soekidjo, a health behavior model based on Benjamin Bloom (1908), states that health is influenced by 2 (two) factors, namely internal factors that include the attitude of knowledge and the characteristics of individuals or groups of people. External factors include the environment, whether physical, social, cultural, economic, which are the dominant factors that influence the behavior of individuals and community groups, for example, the availability of health facilities and infrastructure, attitude and behavior support from community leaders, religious leaders and health workers, individual economic status and community groups.[10]

Various studies state that the values in adolescent life in Indonesia have undergone many changes. One of the most visible changes in society is that teenagers tend to be more permissive to premarital sexual lifestyles.[11] Dating is not a taboo for teens, there is even a view among teenagers that those who are not dating are old-fashioned. Though reproductive health problems that often arise among adolescents are a result of unhealthy dating styles.

Several studies conducted in Indonesia show an increased risk of adolescent sexual behavior. If it is not accompanied by an increase in adequate reproductive health knowledge, it will be difficult for adolescents to avoid risky sexual behavior because they are not exposed to information that can change their views and behavior towards things that are detrimental to reproductive health and their future.

In SKAP 2019, dating behavior is measured by questions including whether teenage respondents had dated, the age of first dating, and whether the survey still had a boyfriend. In addition, respondents were also asked about what sexual behavior is done with a partner when dating (current or previous girlfriend) in expressing affection, which includes holding hands, hugging, kissing lips, touching (touching) or stimulating (stimulated) certain body parts sensitive ones such as around the genitals, breasts, and thighs that are done with a partner / boyfriend / ex-girlfriend.[12]

Of a total of 22,124 male teenagers and 19,458 female adolescents in Indonesia who were respondents SKAP 2019, in total there were 44 percent of adolescents who claimed to have dated (Table 1). The figures in 2019 cannot be compared with the figures of previous years, because at this year the teenage respondents interviewed included a group of young teens aged 10-14 year. This needs to be taken into consideration because of the shift in sexual behavior penetrated in young teens, as well as the age of menarche who are getting younger. So if it happens free sexual behavior can result in pregnancy. Samples of adolescents aged 10-14 years quite

large, namely 19,221 or 46 percent of the total sample of 41,582. As for the sample of teenagers age 15-19 years and age 20-24 years respectively 15,217 and 7,144 people.

Table 1 shows that by sex, the proportion of male teenagers who said they had a boyfriend had a slightly higher percentage than female adolescents (46 percent compared to 42 percent). It was further explained that among male and female adolescents, the proportion of adolescents aged 20-24 years more said that they had ever dated compared to two other age groups. The group of young people who have dated at the least was adolescents of the age group of 10-14 years, it is natural because young teens usually have never dated. It can be said that with increasing age, the opportunity for adolescents to have a boyfriend is greater. The same picture is found in young men and women. Both male and female adolescents claimed that the age at first dating was between the ages of 15-17 years (21 percent and 19 percent, respectively). When viewed on a residential basis, the experience of dating young men and women shows the same pattern. Teenage boys who live in rural areas and never date are greater than those living in urban areas (58 percent versus 50 percent). The same thing is seen in female adolescents who live in rural areas and never date also greater than adolescent girls who live in urban areas (63 percent compared to 55 percent).

Table 1. Age of First Time Dating Distribution of percentage of unmarried adolescents aged 10-24 years according to background characteristics and age of first dating, Indonesia 2019

Characteristic	Age of First Time Dating								Total	Total	Median
	<9	10-14	15-17	18-20	21-22	23-24	Never	Don't Know			
Man											
Age											
10-14	0.9	12.6	0.0	0.0	0.0	0.0	85.6	0.9	100	9.690	12.0
15-19	0.4	22.7	33.6	2.5	0.0	0.0	36.9	4.0	100	8.115	15.0
20-24	0.2								100	4.319	16.0
Living Place											
Urban	0.7	18.1	22.2	5.5	0.5	0.2	50.0	2.8	100	11.367	15.0
Rural	0.4	15.0	19.8	4.4	0.2	0.0	58.0	2.2	100	10.757	15.0
Education											
No Education	0.7	6.5	17.7	0.3	0.0	0.0	73.6	1.2	100	141	15.0
Elementary School	1.1	5.9	4.6	2.2	0.1	0.1	84.9	1.1	100	5.994	15.0
Junior High School	0.4	21.5	11.1	3.1	0.2	0.0	61.3	2.4	100	6.998	14.0
Senior High School	0.3	20.7	38.4	7.5	0.5	0.2	28.7	3.6	100	7.882	15.0
University	0.0	15.9	49.0	13.7	1.6	0.1	15.8	3.9	100	1.108	16.0
Total	0.6	16.6	21.0	5.0	0.3	0.1	53.9	2.5	100	22.124	15.0
Woman											
Age											
10-14	0.3	12.9	0.0	0.0	0.0	0.0	86.1	0.7	100	9.531	12.0
15-19	0.1	20.9	35.3	2.3	2.3	0.0	38.2	3.2	100	7.101	15.0
20-24	0.2	12.2	44.2	44.2	18.9	0.3	17.9	3.8	100	2.826	16.0
Living Place											
Urban	0.4	16.8	20.9	4.2	0.4	0.0	55.0	2.3	100	10.543	15.0
Rural	0.0	14.5	17.3	2.9	0.3	0.1	63.1	1.8	100	8.915	15.0
Education											
No Education	0.0	8.6	6.0	0.0	0.6	0.0	82.9	1.9	100	89	14.0
Elementary School	0.5	4.8	2.1	0.6	0.1	0.0	91.5	0.4	100	5.084	12.0
Junior High School	0.1	21.5	6.1	1.4	0.0	0.0	69.4	1.4	100	5.883	13.0
Senior High School	0.2	19.2	38.1	4.8	0.4	0.0	33.6	3.5	100	6.646	15.0

School											
University	0.1	15.0	42.6	15.0	2.0	0.2	21.5	3.5	100	1.756	16.0
Total	0.2	15.7	19.3	3.6	0.4	0.0	58.7	2.1	100	19.458	15.0

Man+Woman											
Age											
10-14	0.6	12.8	0.0	0.0	0.0	0.0	85.8	0.8	100	19.211	12.0
15-19	0.3	21.9	34.4	2.4	0.0	0.0	37.5	3.6	100	15.217	15.0
20-24	0.2	13.3	44.4	20.0	2.1	0.4	15.9	3.7	100	7.144	16.0
Living Place											
Urban	0.6	17.5	21.6	4.9	0.5	0.1	52.4	52.4	100	21.910	15.0
Rural	0.2	14.8	18.7	3.7	0.2	0.1	60.3	60.3	100	19.672	15.0
Education											
No Education	0.4	7.3	13.2	0.2	0.2	0.0	72.2	1.5	100	231	15.0
Elementary	0.8	5.4	3.5	1.5	0.1	0.0	87.9	0.8	100	11.078	14.0
School											
Junior High	0.2	21.5	8.8	2.4	0.1	0.0	65.0	2.0	100	12.882	14.0
School											
Senior High	0.3	20.1	38.3	6.3	0.5	0.1	31.0	3.5	100	14.528	15.0
School											
University	0.1	15.3	45.1	14.5	1.9	0.1	19.3	3.7	100	2.864	16.0
Total	0.4	16.2	20.2	4.3	0.4	0.1	56.1	2.3	100	41.582	15.0

Based on the level of education, in general it can be seen that adolescents with more elementary education levels have never dated compared to adolescents who have never attended school. The same pattern occurs in young women and men. If seen in general, the higher the level of education, the lower the chance that a teenager will never date, this is natural because the higher the level of education, the more mature the age, so that the opportunity to ever date is greater. In adolescent males with elementary education levels who have never dated (85 percent) are much higher than those with tertiary education (16 percent). A similar pattern occurs in adolescent girls.

Table 1 also provides information about the median age of having a first-time girlfriend. In male and female adolescents aged 10-14 years have a median age of dating 12 years. Among male and female adolescents in the age group of 15-19 years, the average started dating at a median age of 15 years. Teenagers aged 20-24 years are generally dating at the age of 16 years.

Meanwhile, when viewed from a place of residence there is no age difference of having a first-time girlfriend between male and female teenagers. Teenage boys who live in urban areas have the same median age of first-time dating as young men in rural areas (15 years); the same pattern also occurs in adolescent women living in rural and urban areas.

The education level of male and female adolescents does not show any relationship pattern the first age median is dating. Even so, male respondents who had elementary school education first confessed to dating at the median age of 15 years. This picture is different from teenagers women with primary school education, the median age at first dating is 12 years. Teenage male educated junior and senior high school, the median age at the first courtship is 14 and 15 years. While for adolescent girls with junior and senior secondary education, the median age at first dating is lower than male teenagers, 13 and 15 years. For young men and women with college education have the same age of dating age (16 years).[13]

In the 2019 SKAP, teenage respondents who had dated were also asked about premarital sexual behavior during dating. Questions about sexual behavior are very

sensitive questions to be asked to respondents given the contents of the question relate to matters that are very personal and confidential. Sexual behavior during dating asked is about holding hands, hugging, kissing lips, touching / stimulating or not doing anything. These questions are very important to be included in this survey, because one of the tasks of the BKKBN as outlined in the 2015-2019 RPJMN document is to increase youth understanding and awareness about reproductive health and prepare for family life. Therefore information about adolescent sexual behavior is needed as input to develop appropriate strategies so that adolescents have a good understanding and awareness of reproductive health so as to avoid various problems that can arise due to wrong sexual behavior.[7]

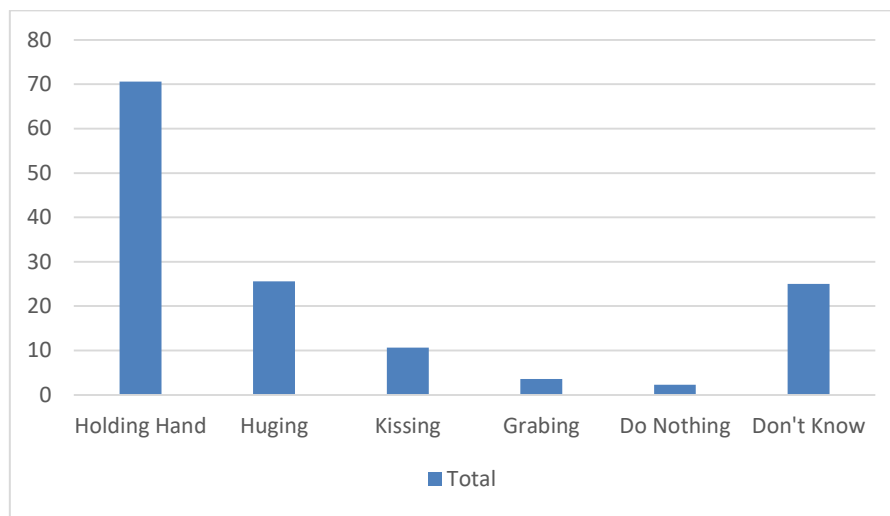

Fig. 1. Percentage of Adolescents aged 10-24 years according to How to Express 'Love' During Dating

In Graph 1 it can be seen that the most common behavior of adolescents when dating is holding hands (71 percent), then hugging (26 percent), kissing the lips (11 percent), and touching or stimulating (four percent). Meanwhile, as much as two percent of respondents said they did nothing (based on the choice of answers on the questionnaire) when dating. One interesting thing is that there are about 25 percent of teenagers who answer don't know when asked what they do to express love during courtship.

Although the way to express affection most teenagers do when dating is 'just' holding hands, but this should still be a concern. Expressing affection by holding hands can lead to other sexual behaviors. In Setiawan and Nurhidayah (2008), quoted from the results of Howard's research (2002) states that the stages of courtship include smiles and friendly views, holding hands, hugging, kissing, touching the top, touching the waist, and engaging in marital relations. So even though holding hands is still possible for adolescents to engage in more preuptial and risky premarital sexual behavior. Therefore, a proper understanding of the effects of sexual behavior must be given to adolescents so that they do not go wrong.[9]

Table 2 shows that male adolescent respondents claimed more sexual behavior such as holding hands, hugging, kissing their lips, and touching or stimulating compared to female respondents. Nearly a third of the total female adolescent respondents who had dated (31 percent) and male teenagers (20 percent) said they did not know what they had done during courtship. When viewed from the age group, adolescents with older age groups have a tendency to engage in sexual behavior while dating. This is found in young men and women. Teenage boys aged 20-24 years who engage in sexual behavior such as hugging, kissing lips and touching / stimulating are 44 percent, 24 percent and nine percent, respectively. The same pattern also occurs in adolescent girls aged 20-24 years, but the percentage is much lower at 33 percent, 12 percent and three percent. Based on the residence can be seen that more male and female adolescents who live in urban areas who have a habit of holding on hands (75 percent of young men who have dated and 68 percent of young women who have dated) compared to rural youth (74 percent of young men and 64 percent of young women). Likewise, adolescents who embrace during dating, the percentage is higher among adolescents who live in urban areas than those who live in rural areas, namely 31 percent of male adolescents who have dated and 22 percent among adolescent girls who have dated compared to 30 percent of adolescents men and 16 percent of teenage girls who have dated.

Table 2. Dating Behavior Percentage of dating behavior of adolescents aged 10-24 years according to background characteristics, Indonesia 2019

Characteristic	Dating Behaviour						Total
	Holding Hands	Hubbing	Kissing	Grabing	Do Nothing	Don't Know	
Man							
Age							
10-14	45,9	8.0	2.0	1.1	5.1	48.0	1.392
15-19	75,2	27.0	10.1	4.1	2.0	20.4	5.123
20-24	83,6	43.8	23.8	8.6	1.8	10.0	3.688
Living Place							
Urban	74,7	30.8	13.7	5.0	2.6	19.5	5.682
Rural	73,7	30.1	14.3	5.7	2.1	21.6	4.522
Education							
No Education	80,3	39.7	8.0	5.5	6.2	13.5	37
Elementary School	64,9	23.4	10.9	4.5	4.5	28.0	906
Junior High School	65,3	24.7	10.6	5.1	2.4	29.7	2.711
Senior High School	78,5	32.2	14.4	4.9	2.0	16.1	5.616
University	83,3	43.3	24.0	9.1	1.8	12.4	933
Total	74.2	30.5	13.9	5.3	2.4	20.4	10.204
Woman							
Age							
10-14	39,9	5.1	1.6	0.5	3.5	56.3	1.329
15-19	67,6	16.5	4.9	1.1	2.4	29.3	4.388
20-24	77,6	33.1	11.5	2.7	1.4	18.8	2.319
Living Place							
Urban	67,6	22.1	7.2	1.6	2.2	29.2	4.749
Rural	63,5	15,6	4.9	1.3	2.3	33.0	3.278

Education								
No Education		76,0	29,2	4,1	3,3	7,7	18,3	15
Elementary School		46,5	16,3	5,1	1,4	4,7	47,4	432
Junior High School	High	52,6	10,3	3,9	1,1	3,4	43,2	1.8001
Senior High School	High	70,2	19,8	6,0	1,4	1,8	27,1	4.411
University		75,7	31,1	10,7	2,3	1,6	21,2	1.378
Total		65,9	19,4	6,3	1,5	2,3	30,8	8.036

Man + Woman								
Age								
10-14		43,0	6,6	1,8	0,8	4,3	52,1	2.721
15-19		71,7	22,2	7,7	2,7	2,2	24,5	9.511
20-24		81,3	39,7	19,0	6,3	1,6	13,4	6.007
Living Place								
Urban		71,4	26,8	10,7	3,5	2,4	23,9	10.430
Rural		69,4	24,0	10,3	3,8	2,2	26,4	7.810
Education								
No Education		79,0	36,6	7,0	4,9	6,0	14,9	53
Elementary School		58,9	21,1	9,0	3,5	4,6	34,2	1.338
Junior High School	High	60,2	19,0	7,9	3,5	2,8	35,1	4.512
Senior High School	High	74,9	26,7	10,7	3,3	1,9	20,9	10.027
University		78,8	36,0	16,0	5,0	1,7	17,6	2.310
Total		70,6	25,6	10,6	3,6	2,3	25,0	18.240

However, kissing lips and fingering are actually done more often by young men in the village than those who live in the city. This picture is different among adolescent women, those who live in cities do more lip kissing than those living in rural areas (seven percent compared to five percent).

Meanwhile, the educational background did not show any pattern of relationship with sexual behavior during courtship both among male and female adolescents. Among young men who are dating and have a college education who claim to hold hands, hug and kiss on the lips (83 percent, 43 percent and 24 percent, respectively). As for teenage girls, the pattern is irregular; adolescent dating and college education claimed the greatest sexual dating behavior was holding hands, hugging and kissing lips (76 percent, 31 percent and 11 percent, respectively).

4 Conclusion

Nearly half of the total adolescents aged 10-24 years in Indonesia claimed to have dated and the highest proportion was male teenagers. The median age of first dating in adolescents both men and women who live in rural and urban areas is the same, namely at the age of 15 years. The higher the adolescent's education, the higher the median age of first dating (14 years in adolescents with elementary and junior high school education; 16 years in adolescents in tertiary institutions). Adolescents who never went to school and claimed to date for the first time at the age of 15-17

years, the proportion is higher than those with elementary and junior high school education (13 percent, four percent and nine percent, respectively). As many as 75 percent of male teenagers and 68 percent of female teenagers who have dated and lived in urban areas generally have the habit of holding hands when dating. In young men who live in urban and rural areas there is a tendency to behave in courtship by hugging, kissing lips, and touching. In adolescent women, the behavior as mentioned above tends to be more practiced by adolescent women in urban areas compared to rural areas. Educational background and wealth index do not show certain patterns of relationships with dating behavior in adolescents.

References

- [1]. Afrilia, E. M., & Cahyanti, Y. D. (2012). Hubungan Sikap Remaja dengan Penggunaan Kontrasepsi pada Anak Jalanan di Pamulang Permai. *Jurnal JKFT:Universitas Muhammadiyah Tangerang*, 2, 8–13.
- [2]. Akib, A. (2019). Faktor yang Berhubungan dengan Pemanfaatan Pelayanan Alat Kontrasepsi KB pada Pasangan Usia Subur di Puskesmas Tamalanrea Kota Makassar 2019. *[JFS] Jurnal Farmasi Sandi Karsa*, 5(1), 71–83.
- [3]. Badan Pusat Statistik (BPS), Badan Koordinasi Keluarga Berencana Nasional (BKKBN), Departemen Kesehatan, dan Macro International Inc. (MI). (2012). *Survei Demografi dan Kesehatan Indonesia 2012*. Jakarta: BPS dan MI.
- [4]. Badan Pusat Statistik (BPS), Badan Koordinasi Keluarga Berencana Nasional (BKKBN), Departemen Kesehatan, dan Macro International Inc. (MI). (2017). *Survei Demografi dan Kesehatan Indonesia 2017*. Calverton, Maryland, USA: BPS dan MI.
- [5]. BKKBN. (2017). *Survei Kependudukan, Keluarga Berencana, Kesehatan Reproduksi Remaja dan Pembangunan Keluarga di Kalangan Remaja Indonesia: Jakarta*
- [6]. Handayani, O. W. K., Wiranti, I., Raharjo, B. B., & Nugroho, E. (2019). The Reproduction Health Behavior of High School Teenagers in Semarang, Indonesia. *The Open Public Health Journal*, 12(1).
- [7]. James B. Weaver, Darren Mays, Stephanie S. Weaver, Gary L Hopkins, Dogan Eroglu & Jay M Bernhardt. (2010). Health Information; Seeking Behaviour, Health Indicators and Health Risk. *American Journal of Public Health*. 100 (8): 1520-1525.
- [8]. Linda Suwarni, Selvian (2015) Inisiasi Seks Pranikah Remaja Dan Faktor Yang Mempengaruhi. *JURNAL KESEHATAN MASYARAKAT*, 10(2): 169-177.
- [9]. Nour, N. M. (2019). Child Marriage: A Silent Health and Human Right Issue. *Women's Health in the Developing World*, 2(1): 51-56
- [10]. Nugroho, E., Nisa, A. A., Rahayu, F. D., Hermawan, D. Y., & Najib, N. (2019). Development of Community-Based Health Communication Models in the Early Marriage Partners. In *5th International Conference on Physical Education, Sport, and Health (ACPES 19)*. Atlantis Press.
- [11]. Nugroho, E., Shaluhiah, Z., Purnami, C. T., & Kristawansari, K. (2017). Counseling Model Development Based on Analysis of Unwanted Pregnancy Case in Teenagers. *KEMAS: Jurnal Kesehatan Masyarakat*, 13(1), 137-144.

- [12]. Odimegwu C, Somefun OD. 2017. Ethnicity, gender and risky sexual behaviour among Nigeria youth: an alternative explanation. *Reprod Health*. 2017;14(1):16. Published 2017 Jan 31. doi:10.1186/s12978-017-0284-7
- [13]. Wana GW, Arulogun O, Roberts A, Kebede AS. (2019). Predictors of risky sexual behaviour among pre-college students in Adama Town, Ethiopia. *Pan Afr Med J*. 2019;33:135. Published 2019 Jun 24. doi:10.11604/pamj.2019.33.135.18068

The Effect of Physical Activity on Body Composition in 9 and 10 Years Old Children

Nawan Primasoni¹, Sugiyanto², Furqon Hidayatullah³, Muchsin Doewes⁴
{nawanprimasoni@student.uns.ac.id¹, sugiyantoprobo@gmail.com², furqon@fkip.uns.ac.id³}

Universitas Sebelas Maret, Surakarta, Indonesia^{1,2,3,4}

Abstract. This study examined the effect of football on body composition in children. It was designed with one group pre and post-test involving 9-year-old (n=22) and 10-year-old (n=18) children at the Football School of Universitas Negeri Yogyakarta. This study was conducted three times a week for six months by measuring height and weight. The pretest results showed, most of children in the 9-year-old group were healthy weight (91%). While the posttest indicated a change. The number healthy weight children was 19, while the underweight and overweight children remained the same. In the 10-year-old group, the most children were also healthy weight (10 children), while the post-test results showed that the number of underweight, healthy, overweight, and obese children were 2, 10, 2, and 4 respectively. Football is a sport with an anaerobic predominant energy system in which to produce energy comes from carbohydrates more than 90% and fat less than 10%.

Keywords: Physical activity, body composition, children

1 Introduction

Physical activity is a basic function of human life. WHO, 2010 physical activity is a movement of the body produced by skeletal muscles that requires energy. Children and adolescents obtain physical health from the physical activity undertaken, including the benefits of bone health [1]. Although there are many benefits of physical activity, not all children can do it well [2]. Physical activity is any bodily movement with the help of muscles, producing energy expenditure, energy in the form (kilocalories) continued from the least, positively correlated with physical fitness [3]. Physical activity that is planned and programmed regularly and aims to improve and to maintain fitness is usually defined as exercise.

Pate (1993) defined exercise as a systematic effort aimed at increasing physical functional capacity and endurance to improve sports performance. Bompa (1990) stated that exercise is a systematic sports activity in a relatively long time to form physiological and psychological functions for achieving certain needs. Exercise provides benefits to the human body, including 1) prevent diseases by expediting body's metabolism and blood circulation, 2) build ideal body growth since the calories

in the body will be used perfectly, and will not lead to fat gain, 3) build a more robust body because it helps all parts of the body to be more flexible [4].

Four main purposes of human to do football as sports include (a). recreation, (b). educational goals, (c). to reach a certain level of physical fitness, (d). to achieve certain goals or achievements. More than 150 articles in 35 international journals that have been reviewed state that football is a sport that is fun, popular, and effective for health. It can be used to establish social relationships and its' positive effects are applicable for all genders and age levels [5-7]. Forty percent of children aged 10 to 18 are fond of football [8].

Body composition is the proportion of fat and fat-free tissue in the body. It means the percentage of fat from the total body weight and Body Mass Index, which is translated into fat and non-fat mass in the body. Muscles, bones, and organs are non-fat mass in the body, while the elements are muscles (40-50%), bones (16-18%), and body organs (29-39%). Fat mass is expressed in percentage of total body weight. In general, it can be concluded that the smaller the percentage of fat, the better the performance of a person.

Assessing body composition can be used to determine the optimal weight for health and physical performance abilities. Some terms that are often used and should not be separated are as follows:

1. Overweight is a deviation from the ideal body weight to height.
2. Overfat is the percentage of excess body fat. In men ideally, it is 2 to 3 percent and in women is 8 to 12 percent.
3. Obesity is the excess of adipose tissue produced by excessive energy intake than the energy expenditure

The growth and development of children are influenced by the environment. Physical activities carried out by children will affect their growth. Physical activity needs to be developed and carried out to prevent adverse effects on other aspects of development [9]. Bone and muscle growth in children is affected by the stimulus of physical activity. Growth norms in children are very closely related to the child's health, body, and mental status [7]. Realizing the importance of growth, in Indonesia, monitoring and measurement of children's body height and weight is performed to observe the child's growth compared to the normal curve

2 Method

The experimental group consisted of 22 children aged 9 years and 18 children aged 10 years who practice football at the Football School of Universitas Negeri Yogyakarta. The sample used the entire population in the range of 9 to 10 years. The physical activity program was implemented through football training and exercise for 90 minutes per session by dividing 15 minutes of warm-up sessions, 60 minutes of core sessions (technical training and games), and 15 minutes of cooling sessions. This study was conducted three times a week for six months at 15.00-16.30 WIB. The training session was led by 4 trainers who supervised and implemented the program. The children's weight was measured with a digital scale and the height was measured

with a calibrated stadiometer. Body mass index was measured using the Excel program. This study was approved by the Faculty of Sport Science, Universitas Negeri Yogyakarta, Health Sports Center, and related parties. After explaining the method to the parents, an agreement was reached between the two parties. Participation in this study was voluntary, children were free to participate and stop at any time. The sample received preliminary tests in May 2019 and treatment for six months. In November 2019, a post-test was carried out in the form of height and weight measurements. Post-tests were carried out in the same place to minimize other variables. The method used in this study was the Quasi Experiment, with one group pretest-posttest design. Data were analyzed with a T-test using SPSS 16.

3 Results and Discussions

The differences in BMI Percentile of the children aged 9 years before and after the treatment were analyzed with a BMI percentile test using the Child Body Mass Index Calculator. The pretest results showed 1 underweight child, 20 healthy weight children (91%), 1 overweight child. While the results of the posttest indicated a change, where there was 1 overweight child, and healthy weight children became 19 children, while the underweight and overweight children remained the same. Based on these results, the differences before and after the treatment is at an average of 18.0 (BMI in kg / m²).

The differences in BMI Percentile in children aged 10 years before and after the treatment was assessed by performing a BMI percentile test using the Child Body Mass Index Calculator. Based on these results, there were 2 underweight children, 10 healthy weight children, 3 overweight children, and 3 obese children. While the posttest results indicated changes, there were 2 underweight children, 10 healthy weight children, 2 overweight children, and 4 obese children. Based on these results, the differences before and after the treatment is at an average of 6.7 (BMI in kg / m²).

BMI-for-age weight status categories and the corresponding percentiles: Underweight (Less than the 5th percentile), Normal or Healthy Weight (5th percentile to less than the 85th), Overweight (85th to less than the 95th percentile), Obese (Equal to or greater than the 95th percentile).

BMI percentile measurement aims to determine the range of a healthy body and can be one of the predictive indicators of health problems. BMI measurements use a measuring tool in the form of a weight scale to measure weight and a stadiometer to measure height. Measurement results can be seen in tables and diagrams. These results can be used to provide an overview and treatment plans for children who are in the underweight category to gain weight to be healthy/ideal, children in the healthy category to maintain the Body Mass Index and most importantly, for children in the overweight and obesity category to lose weight to be healthy/ideal. Children in the healthy weight category will naturally have a small risk of mental and health problems.

Table 1. BMI Frequency Distribution

Category BMI	Terminology	9 years				10 years			
		n = 22				n = 18			
		Pretest		Posttest		Pretest		Posttest	
		n	%	n	%	n	%	n	%
<5th percentile	Underweight	1	4.5	1	4.5	2	11.1	2	11.1
5th–84th percentile	Normal	20	91	19	86.5	10	55.5	10	55.5
85th–94th percentile	Overweight	1	4.5	1	4.5	3	16.6	2	11.1
≥95th percentile	Obesity	0	0	1	4.5	3	16.6	4	22.2
Mean BMI		38.2		56.2		57.8		64.5	
Difference		18				6.7			

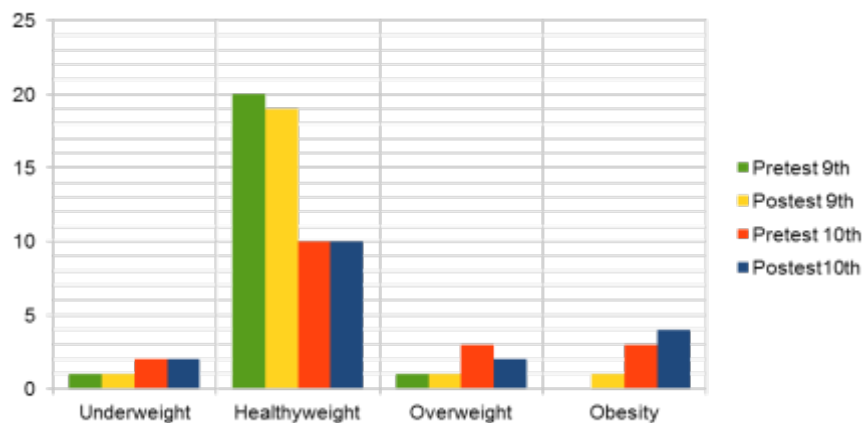
**Fig. 1.** Pretest and posttest BMI percentile

Height and weight ratios, body mass index (BMI), provide another way of categorizing levels of overweight and physical status early. Physical activity has an important role in physical development, psychosocial, and child mentality especially in childhood and early childhood (Dubuy, 2014). The often-quoted health benefits of physical activity for young people include the prevention of obesity; improvement in the framework of health; improved heart and lung function; and better psychological health.

Underweight children can be caused by the consumption of large amounts of food and large amounts of fluid which only fills the stomach but does not supply much energy for children. Active children need additional energy with food. One must also consider genetic predispositions in some cases of underweight children. Genetics, age, sex, nutrition, physical activity, hormonal status, health, and environmental conditions are important for normal weight in children. Some children

may gain weight slowly, others gain weight quickly. Thus, normal weight in children may also be different from this point of view. BMI is a good indicator to determine normal weight, underweight, overweight, and obesity levels in children.

Some documents state that overweight and obesity in children can be a trigger for health problems such as asthma, psychological disorders, and respiratory disorders [10,11]. One of the factors causing overweight and obesity is the lack of physical activity that is both structured daily and monthly. Physical activity routinely carried out from childhood to the old age is very influential in the process and health for life. The causes of obesity in children are numerous and include genetic predispositions, biological factors, behaviors, and cultural specificities. If one parent is obese, the chance of obesity in a child is 50%. When both parents are obese, the chance of being overweight in children is 80%. Obesity in children presupposes reducing the number of calories consumed and increasing the level of exercise.

The treatment includes setting reasonable and achievable weight loss goals, effective diet and physical activity management, changes in behavior patterns, and family participation. Obesity in childhood is a pandemic problem in various countries in the world today. Overweight and obesity are multidimensional problems because almost all groups can be affected, not only the upper-middle socioeconomic group but the middle and lower-middle classes. Determination of nutritional risk is an early detection effort to identify the target group to prevent the incidence of overnutrition and obesity in children and to avoid or reduce the impact of Non-Communicable Diseases. WHO recommends a physical activity program as one of the methods to achieve a healthy body size for children [12].

Experts even emphasize the risk of a new generation becoming less healthy than the previous generation due to the increasing number of overweight children, unhealthy eating, and inadequate physical activity. Prevention of overweight in children is the best approach to avoid problems related to excessive weight gain. Healthy eating and adequate physical activity are the determining factors in cases of being overweight in children. Adequate physical activity is an important approach to weight loss.

Various scientific studies show that overweight can occur due to three factors, namely: a) genes (heredity), b) patterns of physical activity, c) patterns of food consumption. Genetic factors become one of the factors that cause overweight related to the body's metabolic rate. Individuals with slow metabolic rates are more at risk of overweight and obesity. Some health experts reveal that genetic factors are not the main factor in overweight in children, this can be seen by the increasing magnitude of overweight prevalence from year to year, while genetic changes in the last three decades did not occur. Therefore parents do not have to blame heredity but respond to how the pattern of activity and food patterns in children. Eating factors need to be considered. Calories in which is greater than calories out in the body are the determining factors for overweight. Factors of physical activity patterns are factors that can be improved in overweight children. Children with minimal physical activity will be usually overweight. Physical activity with the concept of playing will be very suitable for children. Physical activities such as football are healthier than physical activities of playing video games that require less movement and less energy [13].

A form of endurance physical activity which does not require a fast movement, so the formation of ATP occurs with aerobic metabolism. Adequate oxygen (aerobic

conditions) will occur where the body uses more oxidative energy systems that choose fat as the source of energy used. Glycogen which is the raw material will be broken down completely into CO₂ and H₂O and produce a number of ATP. Aerobic systems produce energy in a relatively long time, but the amount of energy produced is more. So it can be used for longer movements. People who are overweight/obese are advised to do a lot of physical activity or exercise using the aerobic predominate energy system because overweight / obese people have fat reserves that can be used as the body's fuel sources.

Physical activity such as football is one sport with a high level of intensity. Football is a sport with an anaerobic predominant energy system where the energy released to produce energy comes from carbohydrates more than 90% and fat less than 10%. This sport is not suitable for weight loss but it should be considered and investigated, how to implement football with moderate intensity where fat is the main source of energy with changes in the rules and the field.

Table 2. Energy Sources for Various Types of Activities. Source: Giam and Tea (1993).

Aerobic Activity	Intensity		Energy sources (%)	
	VO ₂ Max (%)	Max BPM (%)	Carbohydrates	Fats
Low Mediu, Aerobic	< 50	< 70	25-50	50-70
Medium High Aerobic	50-60	70-80	< 25	> 75
Very Heavy Maximum Aerobic	60-90	80-95	> 90	< 10
Anaerobic	> 90	> 95	> 90	< 10

Physical activity that uses fat as the largest source of energy is moderate to severe aerobic, with a maximum pulse rate of 70-80 percent. Football will be an effective sport in losing weight if the rules and systems are modified so that the maximum heart rate is between 70-80 percent of the maximum heart rate. The role of training or sports teacher is very influential, especially in planning training programs and measuring the intensity of training.

4 Conclusion

Actions to reduce overweight and obesity can be done in various ways, one of which is to exercise. Not all exercise is effective for weight loss. Jogging and walking are forms of exercise that can lose weight, but both types of exercise are relatively boring because of monotonous movements. Children who are fond of football need to be treated specifically with certain rules in pating football to lose weight. It should not reduce the element of fun playing which is an integral part of the lives of children. Football is a sport that emphasizes the concept of play. This can be used as a medium to improve certain skills and abilities in children. Playing helps children to channel more energy to prevent them from negative activities. Besides, playing will function as a process of sublimation to escape from excessive stress toward positive things. The process of sublimation will assist children to be more creative, better, and more

organized in their lives. Aside from the psychological aspect, it also contributes to health and weight loss.

References

- [1]. Barlow, S. E, & et al. (2007). Expert Committee Recommendations Regarding the Prevention, Assessment, and Treatment of Child and Adolescent Overweight and Obesity: Summary Report. American Academy of Pediatrics..
- [2]. Carl J. Caspersen, Kenneth E. Powell and Gregory M. Christenson (1985). Physical Activity, Exercise, and Physical Fitness: Definitions and Distinctions for HealthRelated. Published Vol. 100, No. 2 (Mar. - Apr., 1985), pp. 126-131 by: Sage Publications, Inc.
- [3]. Erick Burhaein (2017). Aktivitas Fisik Olahraga untuk Pertumbuhan dan Perkembangan Siswa SD. Vol 1 No 1 (2017) 51-58 Indonesian Journal of Primary Education. Indonesian Journal of Primary Education -Vol 1 No 1 (2017) 51-58-<http://ejournal.upi.edu/index.php/IJPE/index>.
- [4]. Giam, C.K dan Teh, K.C. 1993. *Sport Medicine Exercise and Fitness*. Singapore: PG Publishing Pte Ltd.
- [5]. Howie, E. K., & Pate, R. R. (2012). Physical activity and academic achievement in children: A historical perspective. *Journal of Sport and Health Science*, 1(3), 160–169. <https://doi.org/10.1016/j.jshs.2012.09.003>.
- [6]. Khan KM, Thompson AM, Blair SN, et al. Sport and exercise as contributors to the health of nations. *Lancet* 2012;380:59–64.
- [7]. Matthew Pearce, Sarah Webb-Phillips, Isabelle Bray. (2015). Changes in objectively measured BMI in children aged 4–11 years: data from the National Child Measurement Programme. *Journal of Public Health | Vol. 38, No. 3*, pp. 459–466 | [doi:10.1093/pubmed/fdv058](https://doi.org/10.1093/pubmed/fdv058) | Advance Access Publication May 6, 2015
- [8]. Tanner, J.M., Whitehouse, R.H., Marubini, E., & Resele, L.F. (1976) The adolescent growth spurt of boys and girls of the Harpenden growth study. *Ann Hum Biol*3:109-26.
- [9]. Oja P, Titze S, Kokko S, et al. Health benefits of different sport disciplines for adults: systematic review of observational and intervention studies with metaanalysis. *Br J Sports Med* 2015;49:434–40.
- [10]. Pedersen BK, Saltin B. Evidence for prescribing exercise as therapy in chronic disease. *Scand J Med Sci Sports* 2006;16(Suppl 1):3–63.
- [11]. Sallis RE. Exercise is medicine and physicians need to prescribe it!. *Br J Sports Med* 2009;43:3–4.
- [12]. U.S. Department of Health and Human Services. (2008). Physical activity guidelines advisory committee report. Washington, DC: USDHHS.
- [13]. Veerle Dubuy, Katrien De Cocker, Ilse De Bourdeaudhuij. (2014). Diet And Physical Activity In Children And Adolescents From A Lower Socio-Economic Background: A Controlled Pretest-Posttest Design. Dubuy et al. *BMC Public Health* 2014, 14:457

Potential of The Red Dragon Fruit (*Hylocereus polyrhizus*) as Antioxidant to Increase Catalase Giving High-Intensity Physical Activity

Novita Sari Harahap¹, Nurhayati Simatupang², Awaluddin Sibuea³,
Suprayitno⁴
{novitahrp74@gmail.com¹, nurhayati@unimed.ac.id², sibueaawal@gmail.com³}

Universitas Negeri Medan, Medan, Indonesia^{1,2}
Dr. T. Mansyur Tanjung Balai Hospital, Tanjungbalai, Indonesia³

Abstract. High intensity physical activity tends to make free radicals more active and cause a decrease in endogenous antioxidants such as catalase. Oxidative stress can be prevented by consuming food like red dragon fruit. The purpose of this study was to determine the potential of red dragon fruit as an antioxidant that can neutralize free radicals cause high-intensity physical activity. The subjects consisted of 20 male students and were divided into 2 group P1 (control); given high-intensity physical activity and placebo, group P2 (treatment) given high-intensity physical activity and red dragon fruit juice. The results showed there was a significant effect of red dragon fruit on to increase of antioxidant catalase in the group P2 compared to the group P1. The conclusion of this study states that red dragon fruit has the potential as an exogenous antioxidant that can neutralize free radicals triggered by high-intensity physical activity.

Keywords: Physical activity, Free radicals, catalase, red dragon fruit

1 Introduction

Owing to increased body metabolism, oxygen consumption in muscle fibers can increase by up to 20 times during high-intensity physical activity[1]. Some organs such as the liver, kidneys, and other organs will experience hypoxia and ischemia during high-intensity physical activity because energy is needed to convert ATP into ADP (Adenosine Diphosphate) and AMP (Adenosine Monophosphate). If the oxygen supply is inadequate, AMP is converted to hypoxanthine. After physical exercise, the blood flow will return to normal through the mechanism of reperfusion, with the enzyme xanthine oxidase converting hypoxanthine to xanthine and uric acid. This process creates free radicals that have lipid peroxidation reactions that damage cell membranes[2].

The body will typically generate its antioxidants in a biological system, such as superoxide dismutase, catalase, and glutathione peroxidase (endogens). Those are

enzymatic antioxidants can neutralize free radicals that are formed in the body [3]. When free radical production exceeds cellular defense antioxidants, oxidative stress can occur [4,5].

Research showed that high-intensity physical activity might cause decreased levels of enzymatic antioxidants such as catalase (CAT), superoxide dismutase (SOD) and glutathione peroxidase (GPx) [6]. Research by Bulduk et al. (2011) reported that volleyball athletes who often run shows free radicals' formation which is characterized by decreased levels of antioxidant catalase and GPx [7].

Decreasing antioxidant levels due to high-intensity physical activity can be prevented by optimizing nutrition especially by increasing the antioxidant content [8,9]. Some research report that consuming natural ingredients is known to increase levels of antioxidant catalase (CAT) and glutathione peroxidase (GPx) [10,11].

One natural food source that contains antioxidants is Red Dragon Fruit (RDF), which is a type of cactus that has been widely discussed in the community, especially in Indonesia due to its beneficial properties for human health. RDF contains natural antioxidant compounds in the form of polyphenols and flavonoids, its function can inhibit and neutralize oxidation reactions involving free radicals, both exogenous and endogenous [12,13]. Polyphenol secondary metabolite compounds such as flavonoids can provide antioxidant effects by preventing the generation of ROS, directly capturing ROS, or indirectly increasing enzymes [14].

The purpose of this study was to determine RDF's potential and its ability to increase the level of antioxidant catalase in students with high-intensity physical activity.

2 Methods

2.1 Ethical recognition

This research was given ethical approval by Universitas Sumatera Utara (No. 59 / KEP / FK USU/2020) of the Ethics Committee on the Application of medical research in the Faculty of Medicine.

2.2 Study design

This work was carried out using an experimental quasy approach with the pre-test and post-test group design. This research was carried out at the Faculty of Sport Sciences' Physical Laboratory, Universitas Negeri Medan, and the Medical Faculty's Laboratory, Universitas Sumatera Utara.

2.3 Subjects

The research subjects consisted of 20 people, male, students of the Faculty of Sport Sciences, Universitas Negeri Medan who were not trained as athletes and had met the following criteria: male, no physical exercise before the research, non-athlete, non-smoker and no consumption of supplements and antioxidants 2 weeks before and during the study's inclusion and exclusion. The study subjects were divided randomly

into 2 groups, each group consisted of 10 students, namely group P1 (control): given a treadmill an intensity of 80-85% of maximum heart rate and placebo, group P2 (treatment) given treadmill an intensity of 80-85% of maximum heart rate and RDF juice. Before the research begins, an explanation is given to prospective research subjects regarding the aims and objectives of the study. Afterward, the samples who are willing to take part in the study signed an informed consent or consent form. Furthermore, in the laboratory of the Faculty of Medicine, Universitas Sumatera Utara, the catalase levels for the pre- and post-test were examined.

2.4 Physical activity procedures

Physical activity is carried out by exercising on a treadmill with an intensity of 80-85% of maximum heart rate, speed level of 10-12, duration 30 minutes, 3 times a week for 21 days. Red dragon fruit juice was given daily at a dosage of 2.8 g / kg BW for 21 days, blended with 70 ml water. Supply of red dragon fruit juice with a dosage of 2.8 g / kgBB smoothed with a blender and then added 70 ml of water for 21 days per day [15]. Research by Khotimah (2018) using the same dose and given for 14 days, the difference is the time of administration of red dragon fruit juice in this study is longer that is for 21 days.

2.5 Catalase measured

Catalase levels was measured used serum by spectrophotometric method ELISA (*Enzyme-Linked Immunosorbent Assay*, reagensia Human Catalase (CAT) ELISA Kit, Catalog Number MBS703074.

2.6 Statistical analysis

Data were analyzed using paired t-test with $\alpha = 0.05$, to test the effect of each variable and Independent sample t-test with $\alpha = 0.05$, to analyze whether there was an effect of red dragon fruit juice consumption on catalytic antioxidant levels. The data obtained were then processed with statistical procedures using SPSS.

3 Results and Discussions

The results of the study as in table 1, show that in the group P1 there was a significant decrease in average catalase levels (124.61 ± 48.45 vs 88.33 ± 54.64 ; $P = 0.037$; $p < 0.05$). In the group P2, there was a significant increase in average catalase levels (113.74 ± 38.30 vs 183.80 ± 71.01 ; $p = 0.001$; $p < 0.05$).

Table 1. Average catalase levels on group

Group	Pre test		Post test		Nilai p
	Mean	sd	Mean	sd	
P1	124.61 (pg/ml)	48.45	88.33 (pg/ml)	54.64	0.037*
P2	113.74 (pg/ml)	38.30	183.80 (pg/ml)	71.01	0,001*

Note : P1= control group; P2= treatment group; sd= standar deviation; *=significant= P<0.05

Further analysis showed that there was a significant increase in catalase levels in the group P1 compared to the group P2 (183.80 ± 71.01 vs 88.33 ± 54.64 ; $p=0.003$; $p<0.05$).

Table 2. Different catalase level on group

Group	Mean	sd	pValue
P1	88.33 (pg/ml)	54.64	0.003*
P2	183.80 (pg/ml)	71.01	

Note : P1= control group; P2= treatment group; sd= standar deviation; *=significant=p<0.05

Based on table 2, it shows that there is an increase in antioxidant levels in the high-intensity physical activity group with red dragon fruit consumption compared to the high-intensity physical activity group that does not consume red dragon fruit (183.80 ± 71.01 vs 88.33 ± 54.64 ; $p= 0.003$; $p<0.05$). Therefore, It can be inferred that red dragon fruit has the capacity as an exogenous antioxidant capable of growing antioxidant catalase rates in students with high physical activity.

A decrease in catalase levels was found in the high-intensity physical activity category which did not drink red dragon fruit juice. The decrease in catalase levels occurred due to reactive free radicals produced during physical activity of high intensity. Oxygen intake increases during high-intensity physical activity due to the rising energy demands of contracting muscles. This rise in oxygen consumption is causing the production of free radicals and Reactive Oxygen Species (ROS) to increase[16]. Decreased rates of catalase in the control group was consistent with research performed by Castro et al. (2009) who reported that training with an intensity of 80 per cent of maximum heart rate decreased levels of catalase compared to training with an intensity of 60 per cent and & 70 per cent of maximum heart rate. This occurs because antioxidants function at an intensity of 80 percent of the normal heart rate during exercise to compensate for the development of free radicals [17].

Free radicals are atoms or molecules with unpaired electrons in their outermost orbits. These unpaired electrons cause the compound to be extremely reactive to look for a pair, by attacking or binding to the electrons of other molecules that are around it, hence new free radicals are formed [18]. Continuously increasing free radicals cause hydrogen peroxide to increase, this condition disrupts endogenous antioxidant activity. It could further decrease the level of endogenous antioxidants and cause an imbalance between oxidants and endogenous antioxidants. A new balance can occur if the body gets additional antioxidants externally [19].

Besides that, this study also found that increasing catalase levels in subject with high-intensity physical activity who consumed natural antioxidants such as red dragon fruit cause red dragon fruit contains natural antioxidant compounds in the form of

polyphenols and flavonoids. The increase in catalase levels happened due to the antioxidant's ability to capture and neutralize free radicals so that further reactions that cause oxidative stress can be stopped and cell damage can be avoided. Antioxidant termination reactions usually occur by capturing hydroxyl radicals at the peroxidation stage of fat, protein, or other molecules on normal cell membranes to avoid cell damage. Neutralization is done by injecting one electron to create a more stable compound, or to induce a termination reaction, and to end radical reactions or to stop oxidative stress in the cell [5].

Oxidative stress prevailed due to insufficient oxygen and nutrients, causing ischemic processes and damage to the microvascular. This condition is called Damage of reperfusion. It can also cause damage to the tissue due to the excessive development of free radicals [20]. Red dragon fruit consumption as an exogenous antioxidant before high-intensity physical activity in treatment group was proven to prevent an increase in free radicals. This is because free radicals which cannot be neutralized by endogenous antioxidants will be neutralized by various antioxidants contained in red dragon fruit. Antioxidants contained in red dragon fruit stabilize free radicals by completing the lack of electrons possessed by free radicals and inhibit the chain reaction of the formation of free radicals that can cause oxidative stress [21]. As a result, the balance between oxidants and antioxidants can be maintained, in other words, oxidative stress can be avoided.

Catalase is an enzyme composed of more than 500 amino acids with a porphyrin group. This enzyme catalyzes the reaction of the compound hydrogen peroxide reduction (H_2O_2) to oxygen (O_2) and water (H_2O). The catalase activity is optimal at pH 7 and can increase with increasing H_2O_2 accumulation. High concentrations of catalase are found in the liver, blood, kidneys, brain, lungs, adipose tissue, and adrenal glands [22].

4 Conclusion

The conclusion of this study states that RDF has the potential as an exogenous antioxidant with the ability to neutralize free radicals that are triggered by high-intensity physical activity marked by increased levels of catalase.

Acknowledgments. This research was funded by the Research and Community Service Directorate, Research and Development Power Deputy, the Ministry of Science and Technology / Research Agency and the National Innovation Republic of Indonesia of the years 2020.

References

- [1]. Powers SK, Jackson MJ. Exercise-Induced Oxidative Stress: Cellular Mechanisms and Impact on Muscle Force Production. *Physiol Rev.* 2008; 88:1243-1276.
- [2]. Ayala A, Munoz MF, Arguelles S. Lipid Peroxidation: Production, Metabolism, and Signaling Mechanisms of Malondialdehyde and 4-Hydroxy-2-Nonenal. *Oxidative Medicine and Cellular Longevity.* 2014. Article ID 360438; 1-31.

- [3]. Rao PS, Kalva S, Yerramilli A, Mamidi S. Free radicals and tissue damage: Role of Antioxidants. *Free Radicals and Antioxidants*. 2011; 1(4): 2-7.
- [4]. Daniel RM, Stelian S, Dragomir C. The effect of acute physical exercise on the antioxidant status of the skeletal and cardiac muscle in the Wistar rat. *Romanian Biotechnological Letters*. 2010; 15(3): 56-61.
- [5]. Zheng W, Wang SY. 2009. Antioxidant Activity and Phenolic Compounds in Selected Herbs. *J.Agric.Food Chem*. 2009; 49(11): 5165-70
- [6]. Thirumalai T, Viviyan TS, Elumalai EK, David E. Intense and Exhaustive exercise induce oxidative stress in skeletal muscle. *Asian Pacific Journal of Tropical Disease*. 2011; 1(1):63-66.
- [7]. Bulduk EO, Ergene N, Baltaci AK, Gumus H. Plasma antioxidant responses and oxidative stress following a 20 meter shuttle run test in female volleyball players. *International Journal of Human Science*. 2011; 8(2): 510-526.
- [8]. Simioni C, Zauli Z, Alberto M, Martelli, Vitale M, Sacchetti, Gonelli A, Luca MN Oxidative stress: role of physical exercise and antioxidant nutraceuticals in adulthood and aging. *Oncotarget*. 2018; 9(24):17181-98
- [9]. Pingitore A, Lima GPP, Mastorci F, Quinones A, Iervasi, Vassalle C. Exercise and oxidative stress: Potential effects of antioxidant dietary strategies in sports. *Nutrition*. 2015; 31(7-8):916-22.
- [10]. Palmer ME, Haller C, McKinney PE, Klein-Schwartz W, Tschirgi A, Smolinske SC, et al. Adverse events associated with dietary supplements: an observational study. *Lancet*. 2003;361(9352):101–6.
- [11]. McLeay Y, Stannard S, Houltham S, Carlene Starck C. Dietary thiols in exercise: oxidative stress defence, exercise performance, and adaptation. *Journal of the International Society of Sports Nutrition*. 2017; 14:12.
- [12]. Nurul SR, Asmah R. Variability in nutritional composition and phytochemical properties of red pitaya (*Hylocereus polyrhizus*) from Malaysia and Australia. *International Food Research Journal*. 2014; 21(4): 1689-1697.
- [13]. Rohin MAK, Hadi NA., Rokiah MY, Asmah, R, Mohd Nasir, M.T. and Siti Muskinah, M. Proximate composition and selected mineral determination in organically grown red pitaya (*Hylocereus* sp.). *Journal of Agriculture and Food Science*. 2006; 34(2):269-275.
- [14]. Akhlaghi M, Brian B. Mechanisms of flavonoid protection against myocardial ischemia–reperfusion injury. *Journal of Molecular and Cellular Cardiology*. 2009; 46 : 309–17.
- [15]. Khotimah K (2018). Pengaruh Jus Buah Naga Merah Dan Senam Terhadap Kadar Hdl Lansia. *Jurnal Kesehatan Kusuma Husada* 213-219
- [16]. Kurkcu R, Tekin A, Özda S, Akçakoyun F. The Effects of regular exercise on oxidative and antioxidative parameters in young wrestlers. *African Journal of Pharmacy and Pharmacology*. 2010; 4(5):244-51.
- [17]. de Castro MAC, Cavalcanti Neto F.F, Lima LMC, da Silva FM, de Oliveira RJ, Zanesco A. Production Of Free Radicals And Catalase Activity During Acute Exercise Training In Young Men. *Biology of Sport*. 2009; 26(2): 113-118
- [18]. Urso ML, Clarkson PM. (2003). Oxidative stress, exercise, and antioxidant supplementation. *Toxicology*. 2003; 189(1-2): 41-54.

- [19]. Sarwat Jahan S, Fatima A., Alam I, Ullah A, Rehman, H, Afsar T, Almajwal A, Razak S. Effects of dietary supplements on selected hematological and biochemical parameters of Pakistani athletes. *BMC Nutrition*. 2018; 4:41
- [20]. Sasaki M, Joh T. *Oxidative Stress and Ischemia Reperfusion Injury in Gastrointestinal Tract and Antioxidant Protective Agents*. 2007
- [21]. Berzosa I, Cebrian L, Fuentes-Broto E, Gomez-Trullen E, Piedrafita E, Martinez-Ballarín L, Lopez-Pingarrón RJ, Reiter and Garcia JJ. Acute Exercise Increase Plasma Total Antioxidant Status and Antioxidant Enzyme Activities in Untrained Men. *Journal of Biomedicine and Biotechnology*. 2011: 1-7.
- [22]. Marciniak A., Brzeszczynska, J. ,Gwozdziński K. and Jegier A., 2009. Antioxidant Capacity and Physical Exercise, *Biology of Sport*.26(3) : 197-213.

Health Cadres in Fighting Dengue Hemorrhagic Fever

Nur Siyam¹, Dyah Mahendrasari Sukendra², Yunita Dyah Pustita Santik³
{nursiyam@mail.unnes.ac.id¹, dyahmahendra@yahoo.com², puspta.santik@gmail.com³}

Universitas Negeri Semarang, Semarang, Indonesia¹²³

Abstract. The number of dengue fever in Semarang City has increased. Community empowerment to realize a village that is able to combat DHF. The purpose to analyze the capacity of village health cadres in the fight against DHF. This type of research is descriptive study. The study was conducted in the endemic area of Semarang City. Data collection instruments are questionnaires and checklist sheets about knowledge and practices of cadres in the fight against DHF. The subject were thirty health cadres. The results showed that the average cadre knowledge value was 84.0%, the average attitude value was 80.8% and the DHF prevention and control practice was 82.5%. The suggestion to increase cadre capacity to realize a village that is able to fight DHF. The community leaders and community participation needed to realize the cadre performance in order to reach the sustainability of the DHF eradication program launched by the government.

Keywords: Health cadres, DHF, Knowledge, Attitude, Practice.

1 Introduction

Dengue Hemorrhagic Fever (DHF) is a disease caused by dengue virus which is transmitted through the bite of the *Aedes aegypti* mosquito as the main vector. Nowadays, dengue fever is still one of the public health problems in Indonesia that cannot be optimally suppressed. The incidence of DHF can increase due to environmental factors, geographical conditions, behavior, and conditions of citizens' immunity [1,2].

One effort that has been made to overcome DHF is focused on eradicating the adult mosquito, *Aedes aegypti*, given the eradication of mosquito nests using chemicals such as larvacides can cause resistance if the dosage is incorrect [3]. Whereas eradication of mosquitoes by fogging can only kill the adults but cannot simultaneously terminate the eggs and larvae [4].

Among the provinces in Indonesia which is still a DHF endemic area is Central Java namely Semarang Regency. The DHF Incidence Rate (IR) recorded in Semarang Regency in 2016 is increased compared to the previous year. DBD IR in 2016 amounted to 98.7 per 100,000 population of 993 cases found and treated. The community still considers that fogging is the most effective way to eradicate DHF so that putting aside mosquito nest eradication (PSN) which is actually the most effective way to eradicate DHF [5].

The emergence of dengue cases in various DHF endemic areas in Semarang is not only caused by environmental conditions, geographical conditions and also the presence of dengue vector mosquitoes, also caused by people's behavior that is not yet aware of the importance of PSN and independent monitoring of mosquito larvae. Eradication of mosquito nests is the main point that can be done to save residents from the danger of dengue. Community empowerment is very much needed to create a Healthy Village that is free of disease vectors, especially the *Aedes aegypti* Mosquito.

The result of environment monitoring in Semarang, shows the practice of eradicating mosquito nests is still poor. The public is not yet aware of the importance of preventing DHF. The water reservoirs in residents' houses are not well managed. In addition, the potential of garbage that is not handled properly can lead to breeding grounds for disease vectors such as *Aedes aegypti* mosquitoes in used bottles, used glass, old tires, etc.

Health cadres are workers from the community who are chosen by the community and work together for the community voluntarily. Community health cadres can also mean men or women chosen by the community and trained to deal with public health problems. Health cadres have a major role in efforts to improve the ability of the community to help themselves to achieve optimal health status. A form of cadre participation is in energy and materials. Cadres also play a role in community development in the health sector through activities carried out at posyandu. Health cadres are expected to be able to provide learning experiences or create conditions for individuals, families, groups and communities [6]. Cadres should be able to open communication, provide information and conduct education to improve knowledge, attitudes and behaviors to help people recognize and overcome their own problems so that The community is aware, willing and able to practice clean and healthy life behavior through a leadership approach (Advocacy), community development (Social Support) and community empowerment [7]. Cadres must be able to increase knowledge, change attitudes and behavior of the community in monitoring DHF vectors because the community is involved in problem solving [8].

The role of the community in making the villages that safe from dengue must begin early. They must be involved and participate actively in the fight against DHF. The control and prevention of DHF must be carried out by all residents coordinated by the Village Health Cadre. Village Health Cadres in the confronting against DHF need to be trained to recognize the signs of DHF symptoms, proper PSN techniques, environmental management, measurement of larval density, how to report suspects / cases of DHF to the party appointed by the local health center. For this reason, research on "Health Cadres in Fighting Dengue Hemorrhagic Fever" needs to be carried out in Semarang with the aim of knowing how much the capacity of health cadres to fighting DHF, so that understanding, practices of dengue prevention by health cadres and to coordinate DHF case reporting between the community, cadres, and health workers.

2 Methods

The research type is observational with quantitative descriptive approach. It was conducted in one of the endemic areas of DHF in Semarang, namely in the Village of Pakintelan, Gunungpati District, Semarang City. The research was conducted from March to May (3 months). Sampling of this research was done by total sampling technique, the number of respondents were 25 health cadres, 1 village midwife, and community leaders (community leader's wife, and Village Elders).

The research was began with coordination with the Village Chief of Pakintelan community RT 01, then carried out socialization to the cadres to convey the purpose and objectives of conducting research. Data was collected by distributing online questionnaires that were made with Google Form and distributed through the WhatsApp group application in the concerned RT. The data taken was the data of knowledge, attitudes and practices. Knowledge data related to the causes of DHF, vector, vector life cycle, breeding grounds, and how to eradicate the vector. Attitude data is related to the cadre's attitude in creating environmental conditions that are not compatible with mosquito breeding. Practical data taken is environmental management data and practices of preventing DHF by cadres both themselves, their families and community members. Descriptive data analysis by looking at the distribution value, frequency and percentage.

3 Results and Discussions

Pakintelan Village is one of the dengue endemic areas which is part of the Gunungpati sub-district, Semarang City which has a high number of dengue cases. The geographical location makes Pakintelan a suitable place to become the habitat of the *Aedes aegypti* mosquito. In addition, the community has high mobility close to densely populated urban areas.

Research activities began on March 2020 with the coordination of the research team. The research began by coordinating and licensing with the head of Pakintelan Village. After being allowed to conduct research, the team coordinated with RT01 community leader and his wife. The research team conducted observations and interviews with community leader's wife and the elder community leaders. All coordination is carried out with an online system because when the research was conducted the Covid-19 Pandemic occurred. After determining the schedule that was adjusted to the leisure time with the cadres, the research team distributed links / pages that must be filled by cadres and conducted interviews with the RT and several Cadres related to the obstacles and efforts made in the fight against DHF.

From the results of interviews and observations with community leaders and village cadres can be concluded that the prevention and control of DHF have been going well. Coordination of the eradication of mosquito nests from the Puskesmas to the regional office is carried out in each RT assisted by health cadres. Waste management and the environment have been done by carrying out environmental cleaning work once a month which is conducted in the first week of every month. Household waste has been managed by the sub-district cleaning staff with a fee of Rp. 25,000 each family. Residents' houses that have large bathtubs that are difficult to drain will al-

ways be monitored and reminded to be drained once a week. Many residents have started raising fish to be able to eat the existing mosquito larvae. Some residents have manipulated the bathroom by using the tub from a bucket. But there are still some who do not care about the surrounding environment, which is still throwing garbage, cans or pots / washbasins into the garden so that it becomes a puddle.

The research involved 25 health cadres. All cadres were female. Cadre characteristics are presented in Table 1.

Table 1. Characteristic of Health Cadre

No	Characteristics	Category	frequency	%
1	Age	31-40	20	80
		41-50	4	16
		51-60	1	4
2	Job	Teacher	5	20
		Worker	5	20
		Others (private sectors, private business)	6	24
3	Education	Housewife	9	36
		Bachelor	3	12
		Senior High	14	56
		Junior High	7	28
4	Coaching/training of DHF	Elementary	1	4
		Ever	10	40
		Never	15	60

Source: Primary Data, 2020

Table 1 shows that most of village health cadres were aged 31-40 years (80%), there was one cadre who aged more than 50 years of age (4%). Health cadres mostly earn a living as private workers and entrepreneurs, namely 24% and housewives (36%). The most recent education of cadres was high school graduated (56%). In addition, most of them had received counseling / training about DHF (60%).

The results showed that values of knowledge, attitudes and behavioral practices of DHF prevention are as follows; an average knowledge score of 84.0%, an average attitude score of 80.8% and an average score of prevention and control of DHF is 82.5%.

Health cadres need guidelines to carry out their role in preventing and controlling DHF in the regions where they are responsible. A guidebook will help and provide instructions so that the activities carried out are on target and in accordance with the objectives. It can contain definitions of dengue fever, signs and symptoms, morphology of *Aedes aegypti* mosquitoes, life cycle of mosquitoes, habits / behavior of *Aedes aegypti* mosquitoes, mosquito breeding sites, ways of preventing dengue and steps to carry out eradication of dengue mosquito nests, control of extraordinary events. DHF, list of important behaviors to prevent it and how to calculate mosquito larvae density. Guidance is given to cadres as a guide in fighting DHF.

Increasing the knowledge of village health cadres about dengue fever can be done through the provision of material and training by puskesmas surveillance officers that are carried out gradually and continuously. The hope is that with increasing cadre knowledge, cadres' attitudes and practices will also improve in fighting DHF. A

good attitude will encourage cadres to always be motivated in carrying out their duties voluntarily. Direct practice that can be done is to identify risky places as mosquito breeding sites. Identification of risky places to be breeding grounds for mosquitoes is carried out by cadres through the form provided.

The physical environment greatly affects the presence of vector of dengue disease [9]. The presence of *A. aegypti* mosquitoes is determined by the specific topography of the place, climate (rainfall, temperature, humidity, and wind speed) and the level of life of the people. In areas with a lot of man-made water reservoirs (drums, jars, bathtubs), many are found *A* [10]. In addition, community behavior factors are very important in controlling environmental conditions around them. It is cadres who are the spearhead of technical implementers in preventing DHF that is closest to the community.

The capacity of village health cadres in the fight against DHF will increase over time with the support of community leaders, stake holders, health workers and the community itself. Health cadres are the people chosen to be able to help solve health problems in the community. Health cadres need to be selected with heterogeneous socio-demographic criteria to be able to become role models in communities with different socio-demographic strands.

Cadre practices in preventing DHF in their own homes will become the foundation in the practice of preventing DHF in the community. Communication, education and information related to dengue prevention are very important given to health cadres so that they are able to invite the community to participate in the eradication of mosquito nests routinely once a week, in unison by all residents and continuously. Health cadres also need to be equipped with knowledge materials about dengue including signs and symptoms, mosquitoes / vectors, appropriate PSN, ways of reporting / coordination if there are cases / suspects and ways of handling and preventing DHF, so that they are able to provide information about behaviors that are at risk of increasing the incidence DBD [11]. The tasks of cadres in the community need to be written clearly in their work program. So that they can immediately take action to improve DHF prevention practices in preventing DHF cases routinely in the community.

A motivating cadre who is always enthusiastic will create a community that has resources and capability readiness and a willingness to prevent and overcome DHF and emergency problems related to DHF. Communities can create healthy lives, and care and respond to health problems in their areas supported by all walks of life. Cadre is very helpful in the success of preventing DHF areas that are prone to DHF and DHF endemic areas [12].

The success of controlling DHF is inseparable from the role of government, stake holders, community leaders, including religious leaders and also related sectors, strengthened by community participation in the Eradication of Mosquito Nest (PSN) [13] Implementing 3M Plus, namely: 1) Drain and brush walls of water reservoirs such as bathtubs once a week, 2) Closing water storage, 3) Recycling items that can hold rain water can be sustainable if there is a high commitment from the health program holder and from the community [14]. These activities are complemented by Plus activities, such as replacing flower vase water, dumping water in water reservoirs in dispensers, sprinkling larvae powder in places that are difficult to clean, maintaining mosquito larvae, and using repellents. DHF control really requires contributions from

housewives, both cadres and non-cadres, because the implementation is closely related to housework that implements a clean and healthy culture in their daily lives [15].

Cadres are expected to be able to provide learning experiences or create conditions for individuals, families, groups and communities [7]. Cadres are able to open communication, provide information and conduct education to improve knowledge, attitudes and behaviors to help people recognize and overcome their own problems so that the community is aware, willing and able to practice clean and healthy life behavior through the approach of the leader (Advocacy), community development (Social Support) and community empowerment [7]. The community is involved in solving the problems they face [8].

Coordination between cadres and village health workers and support of community leaders in preventing DHF will increase the speed and accuracy in handling the environment to prevent DHF in the case of DHF cases, and create a clean and healthy environment [16].

4 Conclusion

Knowledge, attitudes and practices of health cadres become the foundation in the success to fight DHF. The prevention and control of DHF by health cadres must be supported by stakeholders, community leaders and the community itself so that the role of the cadre is carried on optimally. It is recommended that any DHF disease prevention and control program always involve community participation as a cadre, get support from community leaders local health workers and stakeholders.

Acknowledgments

We would like to acknowledge the Institute of Research and Community Service (LP2M) and the Faculty of Sport Science, Semarang State University, which provided research funding.

References

- [1]. K. Alagarasu, T. Honap, Mulay, Bachal, Shah, and Cecilia, "Association of vitamin D receptor gene polymorphisms with clinical outcomes of dengue virus infection," *Hum. Immunol.*, vol. 73, pp. 1194–1199, 2012.
- [2]. N. Siyam, S. A. Wilopo, and M. Hakimi, "Asupan Vitamin D Rendah dan Keparahan Demam Berdarah Dengue pada Anak Usia 1-14 Tahun," *Kesmas UI J. Kesehat. Masy. Nas.*, vol. 9(1), 2014.
- [3]. A. Cornel, J. Holeman, C. Nieman, Y. Lee, C. Smith, and M. Amorino, "Surveillance, insecticide resistance and control of an invasive *Aedes aegypti* (Diptera: Culicidae) population in California," *F1000Research*, vol. 5, p. 194, 2016, doi: Epub 2016/05/10.
- [4]. P. Packierisamy, C. Ng, M. Dahlui, J. Inbaraj, V. Balan, and Y. Halasa, "Cost of Dengue Vector Control Activities in Malaysia.," *Am J Trop Med Hyg.*, vol. 93, no. 5, pp. 1020–1027, 2015, doi: Epub 2015/09/30.

- [5]. N. Siyam, "Integrated and Comprehensive Action to Reduce and Control Dengue Hemorrhagic Fever: A Survey in Pekalongan City, Central Java," *Trop. Med. J.*, vol. 03, no. 1, pp. 85–93, 2013.
- [6]. H. an den Berg, A. von Hildebrand, V. Ragnathan, and P. Das, "Reducing vector-borne disease by empowering farmers in integrated vector management," *Bull. World Health Organ.*, vol. 85, no. 7, pp. 561–6, 2007, doi: Epub 2007/09/05.
- [7]. A. Diliyanti, "PHBS di Lingkungan Pondok Pesantren," [Online]. Available: <http://adenovitadiliyanti-kemprut.blogspot.com/p/phbs-di-pesantren.html>.
- [8]. E. Nalwanga and J. Ssempebwa, "Knowledge and practices of in-home pesticide use: a community survey in Uganda," *J. Environ. Public Health*, pp. 1–7, 2011, doi: Epub 2011/07/22.
- [9]. N. Arunachalam, S. Tana, F. Espino, P. Kittayapong, W. Abeyewickreme, and K. Wai, "Eco-bio-social determinants of dengue vector breeding: a multicountry study in urban and periurban Asia," *Bull World Heal. Organ*, vol. 88, pp. 173–84, 2010.
- [10]. I. Mulyawan, *Pola Sebaran dan Faktor Risiko Kejadian DBD di Kota Kendari Tahun 2010*. Yogyakarta: Universitas Gajah Mada, 2011.
- [11]. N. Siyam and W. Cahyati, "Implementation of School Based Vector Control (SBVC) for the Prevention and Control of Disease Vectors in Schools," *Media Kesehat. Masy. Indones.*, vol. 14, no. 1, 2018.
- [12]. H. Nawalah, M. Qomaruddin, and R. Hargono, "Desa Siaga: Upaya Pemberdayaan Masyarakat di Bidang Kesehatan Melalui Peran Bidan di Desa," *Indones. J. Public Heal.*, vol. 8, no. 3, pp. 91–98, 2012.
- [13]. N. Siyam, "The Facilitation of KD-RS and W2 DHF Report to Improve DHF Surveillance Report," *KEMAS J.*, vol. 8, no. 2, 2013.
- [14]. C. Mutero, D. Schlotter, N. Kabatereine, and R. Kramer, "Integrated vector management for malaria control in Uganda: knowledge, perceptions and policy development," *Malar J.*, vol. 11, p. 21, 2012, doi: Epub 2012/01/17.
- [15]. J. Sommerfeld and A. Kroeger, "Innovative community-based vector control interventions for improved dengue and Chagas disease prevention in Latin America: introduction to the special issue," *Trans R Soc Trop Med Hyg*, vol. 109, no. 2, pp. 85–88, 2015, doi: Epub 2015/01/22.
- [16]. Rina, "Gambaran Persepsi Masyarakat Terhadap Peran dan Motivasi Bidang untuk Menurunkan Angka Kesakitan DBD Di Desa Siaga Margo Mulyo Tahun 2017," *J. Midwifery*, vol. 6, no. 1, pp. 26-32., 2018.

Rice Bran for Diabetes Mellitus Prevention and Snackification

Okta Woro Kasmini Handayani¹, Siti Fathonah², Arif Rahmat Kurnia³
 {oktia_woro@yahoo.com¹, fathonah@mail.unnes.ac.id², arifrk@mail.unnes.ac.id³}

Universitas Negeri Semarang, Semarang, Indonesia^{1,2,3}

Abstract. Snackification is a snack trend as a substitute for staple foods, meanwhile the increasing cases of Diabetes Mellitus in the community are related to consumption of unhealthy diet. The purpose of this research is to analyze the acceptability of target consumers related to organoleptic and hedonic tests at rice bran levels of 20%, and 30% and which product formulas to be recommended. Formula tested with bran level 20% and 30%. Products are made in the form of biscuits. Test is conducted in the form of organoleptic and hedonic test. The results obtained biscuit bar products that have a high sensory quality and most preferably panelists with 30% bran content, with an average or the total value of hedonic test results related to color is rather like, aroma is rather like, texture is somewhat like, and sweet potato taste is somewhat like, and contain carbohydrates of 68.569 gr / 100 gr.

Keywords: Rice Bran, Diabetes mellitus, Snackification, Biscuit Bar

1 Introduction

The consumption trend of snackification, which relies on snack that function as a substitute for large meals and snacks in the millennial community, requires the availability of healthy food, meets the body's energy needs and does not add to the case of Diabetes Mellitus (DM) in the community. DM is a common and chronic disease that has affected individuals worldwide. It is a disease that is a global health problem. Not only it causes complications of blindness, kidney failure, heart attacks, strokes and lower limb amputations, but DM also causes death to the people. In 2016, an estimated 1.6 million mortality were directly addressed to DM and 2.2 million deaths were caused by high blood glucose in 2012 and occurred before the age of 70 years. The World Health Organization (WHO) estimates DM ranks seventh as the cause of death in 2016.[1] By 2040 the number is predicted to reach 642 million, and by 2030, approximately 366 million adults will suffer from DM, of which 75% live in developing countries.[2,3]

Lifestyle or habit is a major factor causing an increase in DM [4-7] cases. One of it is in the form of habits whether it is related to 1) consumption of food that mainly high-carbohydrate or high-sugar contain including high fat which has a response to the potential for increased blood sugar, 2) physical activity, 3) habits in family health

services, is an important factor in the prevention and treatment of DM type 2.[8] The results of the study found several local foodstuffs such as rice bran (bran) and sweet potato have contribution to low blood sugar level.[9-13] Rice bran is a by-product of rice processing that is rich in nutrients such as fibers, minerals, vitamin B complex, vitamin E, essential fatty acids, amino acids, and antioxidants.[14-16] The effect of reducing blood glucose in sweet potato is associated with increased levels of adiponectin which is an adiposity hormone that functions as a process of insulin metabolism¹⁰. These local foodstuffs can be processed to be snacks in a preferred form, and the form of bars (stems) is selected. The purpose of this research is to find out and analyze the acceptability of target consumers for products related to organoleptic and hedonic tests at rice bran levels of 20% and 30%.

2 Methods

The basic ingredients are rice bran, while the additional ingredients consist of yellow yam, cornstarch, soy milk powder, eggs, honey, baking powder, margarine, and oats (Table 1). The VITABRAN formula tested consisted of 2 kinds of bran content (20% and 30%). Equipment used by Kris brand microwave ovens with specifications: 230V-50Hz, 1400W, frequency 2450MHz. Processing of bran flour, VITABRAN products, is done at the UNNES Nutrition Laboratory.

Table 1. VITABRAN Formula

Ingredients	Formula 1	Formula 2
Rice Bran	20 %	30%
Yellow sweet potatoes porridge	40 %	30 %
Maizena flour	14 %	14 %
Soy bean milk powder	10 %	10 %
Baking powder	1 %	1 %
Margarine	10 %	10 %
Honey	5 %	5 %
Eggs	1	1
Oats		

Making rice bran flour is done by: 1) fresh and clean rice bran in a sieve with a diameter of 80 Mesh 2) sterilized with a 121 C temperature autoclave for 3 minutes, dried in a 105 C oven for 1 hour.

The VITABRAN treatment process is carried out by mixing all ingredients according to the formula into one dough that can be formed. Furthermore, formed a bar (stem) with a size of 12x3x2 cm, and sprinkled with oats, then baked in the oven. Organoleptic analysis was carried out to determine the value of color, texture, taste, aroma, which was liked while the hedonic test to find out the preferred formula, which was carried out on all VITABRAN formulas. Sensory Analysis was conducted on trained panelists consisting of lecturers in the Department of Nutrition Study Program IKM, aged 25-40 years, as many as 10 people (5 men and 5 women), using a 9 point quality scale, (1 very low quality and 9 very very high quality good), and follow standard procedures. Aspects considered for analysis are color, texture, sweetness,

aroma, and overall quality. The assessment of product preference level was carried out by 80 consumptive panelists, with acceptance test with a preference scale of 1-9. Value of 1 was very disliked and value of 9 was very very fond. Proximate test is carried out related to carbohydrate content in biscuits.

3 Results and Discussions

The process of making biscuit bar begins by trying 6 formula combinations of ingredients to get a biscuit texture that is not easily broken (compact), the color is not too brown, but with a crispy taste, without changing the composition of the staples, namely 20% and 30% bran content with sweet potato levels of 40% and 30%.

The results of sensory quality scores carried out on 10 panelists (5 men and 5 women), get results, overall the biscuits bar 2 have a higher value of 53, as well as the total value of each aspect reviewed at 309, while the highest value on the aroma aspect was 55 (Table 2).

Table 2. Result of Sensory Quality Review (Organoleptic test)

Product Review	Overall	Color	Aroma	Texture/ crispness	Sweetness	Sweet potato taste	Total Score
	1	2	3	4	5	6	7
Biscuit Bar 1	49	46	48	44	45	45	277
Biscuit Bar 2	53	49	55	52	47	53	309

The result of preference value or hedonic test conducted on 80 consumer panelists as a whole has the highest value on biscuits bar 2 that is equal to 503, and the highest total of all aspects assessed is also found on biscuit bar 2 that is equal to 2962, and the highest value is found on aspects aroma with a value of 515 (Table 3). Proximate test results for carbohydrate content in biscuit bar 1 was 63,214 gr / 100 gr and in biscuit bar 2 was 68,569 gr / 100gr.

Table 3. Result of Hedonic Test

Product Review	Overall	Color	Aroma	Texture/ crispness	Sweetness	Sweet potato taste	Total Score
	1	2	3	4	5	6	7
Biscuit Bar 1	488	484	438	429	447	475	2761
Biscuit Bar 2	503	495	515	509	458	482	2962

Snackification food consumption trends, with the objective of replacing staple foods or large meals that are considered more practical, but can meet the needs of food substances both in terms of quality and quantity, require the availability of healthy food, among others, not adding to the case of DM in the community. The biscuit bar test results concluded that biscuit bar 2 with 30% bran content and 30% yellow yam was the formula chosen by the panelists as a whole assessment (color value, aroma, texture / crispness, sweet taste). Although the rice bran content in bis-

cuit bar 2 is higher (30%) than the rice bran content in biscuit bar 1 which is 20%, it is not a problem for panelists, this is possible because the composition arising from the added sweet potato content can create aroma and texture. / crispness become more acceptable to panelists. This is reinforced by the qualitative data as a complement that is obtained namely:

“Biscuit number one is a bit soft or less crispy, I really like number two. Is this made from rice bran? how come it doesn't taste, just like biscuits made from flour, if it doesn't cause a rise in blood sugar quickly, I want to also provide snacksbiscuit”

Based on the results of proximate test biscuit bar 2 has a higher carbohydrate content.

Higher carbohydrates in biscuit bar 2 than in biscuit bar 1, with a difference of 5.355 can still be tolerated because of the effect of rice bran given in more concentrations in biscuit bar 2, is expected to affect the lower Glycemic Index (IG). The Glycemic Index is the time needed for an increase or speed in which an increase in blood sugar levels occurs after consuming food equivalent to 50 g of carbohydrate.[19] As the results of research that states that the speed of increase in blood sugar levels differ in each food ingredient, in this case classified as low GI <55, moderate IG 55-70, and high IG > 70. Carbohydrates that are broken down quickly in the body during digestion have high IG values, whereas carbohydrates that are broken down slowly release glucose into the blood so slowly that it has a low IG.[20] Rice bran is a food that is widely obtained in the community at very cheap prices and has the potential as a functional food for preventing DM. Rice bran contains 34% -62% carbohydrates, 15% -20% fat, 11% -15% protein, 7% -11% fiber, minerals, such as Phosphorus, Potassium, Magnesium, Calcium, and strong anti-oxidants.[12,13] Magnesium in rice bran can cause increased glycemic control and prevent insulin resistance or resistance to work optimally¹⁴, while strong antioxidants in rice bran can help manage the onset of DM associated with oxidative stress.[12] Supporting research results suggest that the anti-diabetic effects arising after rice bran supplementation are synergistic effects of various compounds such as acylated steryl glycerides, flavonoids, resveratrol, oryzanol, ferulic acid, policosanol, tocotrienol, hydroxycinnamic acid derivatives and some bioactive peptides.[21]

Biscuit substitution in this research was added to other ingredients, especially food which is a local food ingredient, namely yellow yam (*Ipomoea batatas*) to add effects to product results related to taste, color, aroma, texture and especially its effect on blood sugar levels and to make products more acceptable. Proximate analysis of yellow yam per 100 grams are: energy 86 kcal, carbohydrate 20.12 g, protein 1.57 g, fiber 3 g, lipid 0.05 g, various kinds of vitamins and most are vitamins, various minerals such as Calcium 30.78 mg, Iron 0.61 mg, Magnesium 25.70 mg. The effect of reducing blood glucose in sweet potatoes is associated with increased levels of adiponectin which is an adiposity hormone that functions as a metabolic process of insulin.[10] Besides biscuits, soy milk also added with egg. Other ingredients are cornstarch to produce optimal shape, taste and nutritional content, and egg yolks to glue the oats to the biscuits.

The results of other research found that the originator of DM related to eating habits consumed was a fairly dominant factor,[22] so the selection of food ingredients for snackification should consider the benefits and side effects caused.

4 Conclusion

The biscuit bar test results concluded that biscuit bar 2 with 30% bran content and 30% yellow yam was the formula chosen by the panelists as a whole assessment (color value, aroma, texture / crispness, sweet taste), with a carbohydrate content of 68.569 gr / 100gr. Food ingredients for snackification must consider the benefits and side effects caused and likeness of the target consumer.

References

- [1]. Kementrian Kesehatan RI. 2014. *Situasi Dan Analisis Diabetes*. Kementrian Kesehatan RI, Pusat Data dan Informasi.
- [2]. International Diabetes Federation. 2015. *IDF Diabetes Atlas 7th Edition*. Brussels: International Diabetes Federation. <http://www.diabetesatlas.org>.
- [3]. Sandra G Sosa Rubí, Omar Galárraga, Ruy López Ridaura. 2009. Diabetes treatment and control: the effect of public health insurance for the poor in Mexico. *Bulletin of the World Health Organization*, 87:512-519.
- [4]. Edin Begic, Amira Arnautovic, and Izet Masic . 2016. Assesment Of Risk Factors For Diabetes Mellitus Type2. *Mater Sociomed*, 28(3): 187–190.
- [5]. Ambepitiyawaduge Pubudu De Silva et.al. 2012. Social, cultural and economical determinants of diabetes mellitus in Kalutara district, Sri Lanka: a cross sectional descriptive study. *Int J Equity Health*, 11: 76.
- [6]. Maha Alsejari. 2016. Sociocultural Characteristic, Lifestyle, and Metabolic Risk Factors Among a Sample of Kuwaiti Male University Students. *American Journals of Men's Health* 11 (2): 308-317
- [7]. Than Than Aye, Moe Wint Aung, Ei Sandar Oo. 2014. Diabetes mellitus in Myanmar: Socio-cultural challenges and strength. *J Soc Health Diabetes* 2:9-13
- [8]. Karmeen D. Kulkarni. 2004. Food, Culture, and Diabetes in the United States. *Clinical Diabetes*, 22(4)
- [9]. Trisnawati, W. 2015. Pemanfaatan Tepung Bekatul dan Tepung Labu Kuning Sebagai Bahan Keripik Simulasi Kaya Serat dan Antioksidan. (Disertasi). Pascasarjana. Universitas Udayana, Denpasar.
- [10]. Taiwo Betty Ayeleso¹, Khosi Ramachela² and Emmanuel Mukwevho¹. 2016. A review of therapeutic potentials of sweet potato: Pharmacological activities and influence of the cultivar. *Tropical Journal of Pharmaceutical Research* December 2016; 15 (12): 2751-2761
- [11]. Manali Chakraborty, Savita Budhwar, Pooja and Vinod. 2018. Nutritional and therapeutic value of rice bran. *IJGHC*, June 2018 – August 2018; Sec. A; Vol.7, No.3, 451-461.

- [12]. Bhagavathi Sundaram Sivamaruthi, Periyainaina Kesika, Chaiyavat Chaiyasut. 2018. A comprehensive review on anti-diabetic property of rice bran. *Asian Pacific Journal of Tropical Biomedicine*
- [13]. Kangabam Rajiv Das, Kangabam Medhabati, Khumukcham Nongaleima and Huidrom Sunitibala Devi. **2014**. The Potential of Dark Purple Scented Rice- From Staple Food to Nutraceutical. *Current World Environment* Vol. 9(3), 867-876 (2014)
- [14]. Astawan, M. 2009. Bekatul Gizinya Kaya Betul. Diakses dari : <http://www.kompas.com>. Tanggal : 19 Pebruari 2012.
- [15]. Damayanthi, E., L. Kustiyah., M. Khalid., dan H. Farizal. 2010. Aktivitas Antioksidan Bekatul Lebih Tinggi Daripada Jus Tomat Dan Penurunan Aktivitas Antioksidan Serum Setelah Intervensi Minuman Kaya Antioksidan. *Jurnal Gizi dan Pangan*, 5(3): 205-210.
- [16]. Pasha, I., M.S. Butt, F.M. Anjum, dan N. Shahzadi. 2002. Effect of Dietetic Sweeteners an the Quality of Cookies. *Int. J. Agric. Biol.* 4(2). 245- 248.
- [17]. Meilgaard, M., G.V. Civille, and B. Thomas Carr. 2007. *Sensory Evaluation Techniques*. 2 nd ed. CRC Press, Inc. London.
- [18]. Setyaningsih, D., A. Apriyantono, dan M.P. Sari. 2010. *Analisis Sensori untuk Industri Pangan dan Agro*. Bogor : IPB Press.
- [19]. Yokoyama, W. 2004. Nutritional Properties of Rice and Rice Bran. In : Champagne, E.T. (Ed). *Rice : Chemistry and Technology* 3rd Edition. American Association of Cereal Chemists Inc., Minnesota.
- [20]. Rimbawan dan A. Siagian. 2004. *Indeks Glikemik Pangan*. Penebar Swadaya, Jakarta
- [21]. Nancy Saji, Nidhish Francis, Lachlan J. Schwarz, Christopher L. Blanchard and Abishek B. Santhakumar . 2019. Rice Bran Derived Bioactive Compounds Modulate Risk Factors of Cardiovascular Disease and Type 2 Diabetes Mellitus: An Updated Review. *Nutrients* 2019, 11, 2736; doi:10.3390/nu11112736
- [22]. Handayani OWK, Rr Sri Ratna Rahayu. 2019. Laporan Penelitian Pengembangan Perspektif Sosioantropologi Gizi Dalam Penekanan Kasus Diabetes Millitus Di Daerah Urban dan Sub Urban. LP2M UNNES
- [23]. Author, F.: Article title. *Journal* 2(5), 99–110 (2016).
- [24]. Author, F., Author, S.: Title of a proceedings paper. In: Editor, F., Editor, S. (eds.) CONFERENCE 2016, LNCS, vol. 9999, pp. 1–13. Springer, Heidelberg (2016).
- [25]. Author, F., Author, S., Author, T.: Book title. 2nd edn. Publisher, Location (1999).
- [26]. Author, F.: Contribution title. In: 9th International Proceedings on Proceedings, pp. 1–2. Publisher, Location (2010).
- [27]. LNCS Homepage, <http://www.springer.com/lncs>, last accessed 2016/11/21.

Basic Movements of The Split Leap Rhythmic Gymnastics

Ranu Baskora Aji Putra¹, Tommy Soenyoto², Agus Darmawan³, Roas Irsyada⁴
 {ranu_baskora@mail.unnes.ac.id¹, tommysoenyoto@mail.unnes.ac.id²,
 agus.putri12@gmail.com³}

Universitas Negeri Semarang, Semarang, Indonesia¹²³⁴

Abstract. The perfection of the Split Leap movement in a series of rhythmic gymnastics contributes an assessment of the optimal performance of a rhythmic gymnastics athlete. The purpose of this study was to examine the Split Leap movement in rhythmic gymnastics in physiological, biomechanical and athlete rhythmic gymnastics performance studies. This study using the Systematic mapping study methods. Writing about this split jump is analyzed using articles and books that are relevant to the topic of study that have been mapped before. Five databases were sought for empirical research published between 2003 and 2020. The study map was drawn from various reviews on the part of the connection with a review of research results and articles on topics around the SL movement as many as 41 articles. The relationship between strength, leg flexibility, range of motion, understanding of motion techniques and Physiological support are key to split leap motion.

Keywords: Split Leap, Rhythmic Gymnastics, and Split Jump.

1 Introduction

Rhythmic gymnasts have a basis for movement which will later be combined with rhythm. The basic motion absolutely must be mastered in the form of ballet-shaped free hand movements. Ballet movements include spinning, bending, balance, stepping, and jumping movements. The basic movement of a jump consists of two types of jumps using two legs and one foot, many of which can be formed from the base of this jump one of the most preferred and beautiful looks of split leap (SL). SL is a jumping motion that can use two legs when take off and swing one foot forward and the other backward so that when flying both legs stretch wide. [1,2] In beginner athletes, the SL movement is very difficult, this is due to factors supporting SL mastery of motion not yet optimally developed. The supporting factors are the physical component of explosive power, leg flexibility and improper SL movement techniques. A trainer is required to handle and direct it through a continuing training program. The purpose of this article is to describe and study the split leap move examine the Split Leap movement in rhythmic gymnastics in physiological, biomechanical and athlete rhythmic gymnastics performance studies in various reviews based on a literature review of articles and books.

flexibility so that it is easy to form. The next level is the middle age of 9-12 years with the characteristics of skills that begin to develop in basic movements, the advanced level of the age of 12-14 years some of the ability to move has been well mastered. Junior age ranges from 14-16 years, where a lot of vocabulary is supported by physical and anthropometric abilities that support his skills. While the Senior Level is more than 16 years old, where the development of motion, physical abilities, anthropometrics has adapted to become a professional rhythmic gymnast. In rhythmic gymnastics athletes coordinating motion, static balance, dynamic balance, the reaction develops rapidly compared to other physical items. [7]. In rhythmic gymnastics athletes coordinating motion, static balance, dynamic balance, the reaction develops rapidly compared to other physical items.[8,9]

3.2 Physical Conditions of Rhythmic Gymnasts

The dominant physical components of SR include anthropometrics in the form of body composition which tends towards lean (ectomorphic)[10,11] and sleek with an average delayed menarche [12,13], flexibility of the body in the form of passive and dynamic, range of motion for each joint in the optimal category.[14,15], coordination [6,16-17], speed, accuracy and reaction.[18]. In rhythmic gymnastics athletes coordinating motion, static balance, dynamic balance, rapidly developing reactions compared to other physical items [7,19-20]. According to research [21] that the physical component for rhythmic gymnast influences the appearance of as much as 15% of all other components which include psychology, levels of motion techniques, competitive experience, personality styles, difficulty factors, understanding music and intelligence levels.

3.3 Rhythmic Gymnastic Motion Techniques

At this level the peak rhythmic gymnast achievement is seen and achieved. Like most gymnastics, RG has elements that will be judged in its appearance, namely the artistic side, the series fused, the music and its movements, and the expression [3]. In an RG official race a gymnast is judged by several judges with the following criteria. The arithmetic judge judges in general the choreography of a series of movements in general including the quality of foot skills. Jury D (difficulty) assesses the benchmark final value based on the applicable Code of Point (CoP). Whereas Jury E (Execution) supervises errors of movement both in terms of artistic and technical errors of motion. From these consequences rhythmic gymnasts are expected to have perfect skills both in terms of movement techniques and choreography of the series. In order to achieve high movement techniques the gymnast should have a solid foundation of motion. Basic movements that must be mastered perfectly so that the development of vocabulary variation reaches optimal motion. The basis of rhythmic gymnastic motion is not much different from the dominant pattern of motion in gymnastics in general, namely landing, rotation, jumping, pedestal (static position), locomotor, non-locomotor and manipulative. Rhythmic gymnastics landing is one of the important techniques, landing in SR includes foot landing, landing with rotation, landing with back, etc.

3.4 Split Jump

Split jumping is one of the movements that has beauty, and the appearance of motion that shows the flexibility and flexibility of a joints as wide as possible. Research says that static rhythmic gymnast. Split Jump Movement is essentially a movement stretching the width of the legs to the limits of the ability to stretch the joints. The rhythmic gymnast requires heating both static and dynamic joints in order to stretch the stretching will reduce imperfections in split leap.[22,23] The types of split jumps are Split leap, Stag leap, wallmonkeys, scissors leap.



Fig. 2. scissors leap, Stag Leap, split lep.

Split leap in the appearance of motion is divided into 3 namely the preparation phase, the floating phase and the final phase (landing). In the preparation phase / prefix begins with a vertical jump using bent / semisquat limbs. Pressing the floor and rejecting it in an elastic way can quickly move the weight point. The sudden movement of limbs against gravity causes us to be able to float. But it starts with locomotor motion with polka or gallop. [24]

The gymnast's floating phase forms the legs stretching to the maximum and ready to land. This phase of style leap can be done using stag leap, split leap or something else. the strength, flexibility and coordination of the gymnast is crucial in this floating phase of 65%. [25]

The gymnast's landing phase reduces speed and stabilizes the body using leg muscle strength and a good body balancing ability followed by preparing to land on the mat using legs to resist gravity. Split jumping can also be done using tools or without tools. The appearance of a rhythmic gymnast in a split jump will be maximized if done without using a tool. [26]

3.5 Split Jump Biomechanics Study

Split leap in the initial phase requires movement to move with a certain speed. split leap start speed. [27] To see the speed of the prefix, use the moving formula $V = \frac{s}{t}$ the unit $m.s^{-1}$

information s = distance traveled (m meters), t = time (seconds) traveled. The initial speed of the gymnast can be in the form of a jog, sase, or other steps. The initial speed will determine the success of the core movement. [28] Each gymnast who initiates can feel the right time to change the initial speed into another movement. In

accordance with Newton's law the object will remain stationary or move at a constant speed if there is no force acting on it.[29]

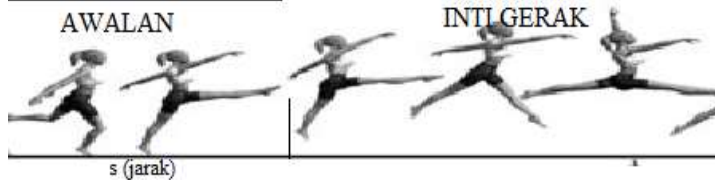

Fig. 3. Prefix Speed Before Split Jump

In the core phase, the gymnast's movement will change the forward horizontal momentum towards the vertical direction (above). This is where the role of gymnast explosive power is needed in the calculation of biomechanical force ($F = m \cdot a$ Newton's unit where m is the gymnast's mass, a is its acceleration. [30] The acceleration obtained by the gymnast from the split jump prefix can be calculated by the formula $a = \frac{v}{t}$ unit $m \cdot s^{-2}$. In accordance with Newton's third law that the vertical force downward when the foot hits the mat, the mat will give the same amount of force and the opposite direction that is above the air. Furthermore, the gymnast will display split movements when floating in the air. It was then that the leg joint flexibility played a role in spreading its width so that the angle of range of motion was about 180° . Rhythmic gymnasts would be reduced in value by judges if the leg ROM was less than 180° range and it was not even acknowledged at all that the movement was a split leap. Research [22] stated that the reduction in the value of the split leap movement that was most caused by the jury was due to the moment of hovering by 0.9 connectedness with its appearance, compared to the length of the jump, ankle point and landing time. As in Figure 4 the following is a reduction by a jury:



Fig. 4. Reduction in value by judges during Split Leap

The final phase of the split leap movement is landing. This phase is essentially a reduction in the forces acting on the body to fight the force of gravity so that the body is stable and balanced both in silence and will be arranged in the next movement. Research[27] states that leg strength must be met in order for a balanced landing for a series of movements, the maximum peak torque sequence from highest to lowest values is found in the hips ($5.81 \pm 1.06 \text{ Nm / kg}$), ankles ($3.56 \pm 0.71 \text{ Nm / kg}$) and knees ($2.01 \pm 0.75 \text{ Nm / kg}$) Whereas for a split leap landing at rest a greater leg force is required ($5.69 \pm 2.45 \text{ kN / m}$).

3.6 Split Leap Physiological Studies

The beauty of a split leap performed by a rhythmic gymnast cannot be separated from the slender rhythmic gymnast's posture with an average level of legs.[31,32] The physical development of the gymnast to become leaner, better coordinated and strong is the result of a long training process. So that the beginning of rhythmic gymnastics exercises determine its physical development. Gymnasts who start training at the age of 6 years will have better development of movement when compared to older ones as the beginning of training if the speed of learning and portion of training are the same. This is due to the practice habits that will foster physiological adaptations from an early age regarding bone density [33], less fat percentage [34], and efficiency in moving due to the development of the nervous system.[35]. Courage and persistence in learning split leap movements will facilitate the rhythmic gymnast in arranging all movements and harmonizing with musical accompaniment. From the psychological side it will also affect that the length of rhythmic gymnastics will have a positive influence on how the gymnast organizes the stresses that have metabolic and physiological effects.[36]. Satisfaction and awareness of the gymnast's body purpose will affect the attitude and appearance in rhythmic gymnastics.[37,38] Courage and persistence in learning split leap movements will facilitate the rhythmic gymnast in arranging all movements and harmonizing with musical accompaniment

3.7 Coach support

Foresight of the trainer in making an exercise program with a sufficient portion of training also contributes greatly to each success in the performance of rhythmic gymnastics athletes. Rhythmic gymnastics trainers have specific specifications in knowledge such as choreography of movements, selection and editing of music and play a role in athlete training sessions.[21] Professional trainers equip themselves with a variety of knowledge [39] about motion mechanics, psychology [40], physiology and even about handling injuries.[41] The trainer will always coordinate continuously with parents to continue to monitor the development of the training program provided to see the effect of the exercise on attitude, mental, physiological adaptation and cognitive development outside of the exercise. Good cooperation between parents and trainers in supporting gymnasts will improve the development of performance / appearance in their careers on rhythmic gymnastics. The appearance of a rhythmic gymnast with a variety of movements having a high difficulty factor is in harmony with the accompanying music so that capturing the attention of the jury and the audience is the ultimate goal of a training. But the actual impact of long training will provide tremendous benefits for the development of the overall potential of a rhythmic gymnast in terms of physical, anthropometric, mental, knowledge and social.

4 Conclusion

Split leap is part of the motion element of a series of movements performed by a rhythmic gymnast. A beauty of movement that involves all the potential rhythmic gymnasts who develop towards the perfection of his appearance optimally. The relationship between strength, leg flexibility, range of motion and understanding of motion techniques are key to split leap motion. Further research is needed on how much the contribution of physical factor proportions, psychology and technical understanding of the appearance of split leap movements. The effects of split leap training will provide benefits for the potential development of gymnastics athletes, increase knowledge and vocabulary of movement in a series of rhythmic gymnastic movements.

References

- [1]. Cicchella A. Kinematics analysis of selected rhythmic gymnastic leaps. *J Hum Sport Exerc.* 2009;
- [2]. Purenović T, Bubanj S, Popović R, Stanković R, Bubanj R. Comparative kinematics analysis of different split front leaps. *Sport Sci.* 2010;
- [3]. Kritikou M, Donti O, Bogdanis GC, Donti A, Theodorakou K. Correlates of artistry performance scores in preadolescent rhythmic gymnasts. *Sci Gymnast J.* 2017;
- [4]. Chiat LF, Ying LF. Importance of Music Learning and Musicality in Rhythmic Gymnastics. *Procedia - Soc Behav Sci.* 2012;
- [5]. Zisi V, Giannitsopoulou E, Vassiliadou O, Pollatou E, Kioumourtzoglou E. Performance level, abilities and psychological characteristics in young junior rhythmic gymnasts: The role of sport experience. *Int Q Sport Sci.* 2009;
- [6]. Purenović-Ivanović T, Popović R, Stanković D, Bubanj S. THE IMPORTANCE OF MOTOR COORDINATION ABILITIES FOR PERFORMANCE IN RHYTHMIC GYMNASTICS. *Phys Educ Sport.* 2016;
- [7]. Zisi V, Giannitsopoulou E, Vassiliadou O, Pollatou E, Kioumourtzoglou E. Performance level, abilities and psychological characteristics in young junior rhythmic gymnasts: The role of sport experience. *Int Q Sport Sci.* 2009;4:1–13.
- [8]. Purenović-Ivanović T, Popović R, Bubanj S, Stanković R. Body composition in high-level female rhythmic gymnasts of different age categories. *Sci Sport.* 2019;
- [9]. Piazza M, Battaglia C, Fiorilli G, Innocenti G, Iuliano E, Aquino G, et al. Effects of resistance training on jumping performance in pre-adolescent rhythmic gymnasts: A randomized controlled study. *Ital J Anat Embryol.* 2014;
- [10]. Purenović-Ivanović T, Popović R. Somatotype of top-level Serbian rhythmic gymnasts. *J Hum Kinet.* 2014;
- [11]. Klentrou P, Plyley M. Onset of puberty, menstrual frequency, and body fat in elite rhythmic gymnasts compared with normal controls. *Br J Sports Med.* 2003;
- [12]. Ávila-Carvalho L, Klentrou P, Palomero M da L, Lebre E. Body composition profile of elite group rhythmic gymnasts. *Sci Gymnast J.* 2012;

- [13]. Czajkowska M, Plinta R, Rutkowska M, Brzęk A, Skrzypulec-Plinta V, Drosdzol-Cop A. Menstrual cycle disorders in professional female rhythmic gymnasts. *Int J Environ Res Public Health*. 2019;
- [14]. Santos AB, Lemos ME, Lebre E, Carvalho LÁ. Active and passive lower limb flexibility in high level rhythmic gymnastics. *Sci Gymnast J*. 2015;
- [15]. Luo L. Study on Quality Indicator System of Rhythmic Gymnasts in Analytic Hierarchy Process. In: *IOP Conference Series: Earth and Environmental Science*. 2017.
- [16]. Rehab Hafez A. IMPACT OF COORDINATION ABILITIES PROGRAM ON ACCURACY AND SPEED IN RHYTHMIC GYMNASTICS. Romania The journal is indexed in: Ebsco, SPORTDiscus, INDEX COPERNICUS JOURNAL MASTER LIST. 2016.
- [17]. Ferro-sánchez A, Galan MR, Villacieros J. Analysis of the coordination and the sequence of corporal movements in the split jump of rhythmic gymnastics. In: *XXXVI Congress of the Iberian Society of Biomechanics and Biomaterials*. 2013.
- [18]. Giannitsopoulou E, Zisi V, Kioumourtzoglou E. Elite performance in rhythmic gymnastics: Do the changes in code of points affect the role of abilities? *J Hum Mov Stud*. 2003;
- [19]. Di Cagno A, Battaglia C, Fiorilli G, Piazza M, Giombini A, Fagnani F, et al. Motor learning as young gymnast's talent indicator. *J Sport Sci Med*. 2014;
- [20]. Sobera M, Rutkowska-Kucharska A. Postural Control in Female Rhythmic Gymnasts in Selected Balance Exercises: A Study of Two Cases. *Polish J Sport Tour*. 2019;
- [21]. Qiong X. Analysis of influencing factors on performance of rhythmic gymnasts. In: *Advanced Materials Research*. 2013.
- [22]. Rodríguez Galán LM, Gómez-Landero Rodríguez LA. Performance variables and technical penalties of the split leap. *Rev Int Med y Ciencias la Act Fis y del Deport*. 2018;
- [23]. A. DC, C. B, C. B, M.C. G, M. V, M. P, et al. Preexercise static stretching effect on leaping performance in elite rhythmic gymnasts. *Journal of Strength and Conditioning Research*. 2010.
- [24]. Borisova V V., Titova A V., Shestakova TA. Special footwork quality improvement method for junior rhythmic gymnasts. *Teor i Prakt Fiz Kult*. 2019;
- [25]. Miletic D, Sekulic D, Wolf-Cvitak J. The leaping performance of 7-year-old novice rhythmic gymnasts is highly influenced by the condition of their motor abilities. *Kinesiology*. 2004;
- [26]. Mkaouer B, Amara S, Tabka Z. Split leap with and without ball performance factors in rhythmic gymnastics. *Sci Gymnast J*. 2012;
- [27]. Bąkiewicz M, Kępczyński A, Wit A. Comparative Analysis of Kinetics Parameters during Different Landing after Split Front Leaps. *Polish J Sport Tour*. 2019;
- [28]. Coppola S, Albano D, Sivoccia I, Vastola R. Biomechanical analysis of a rhythmic gymnastics jump performed using two run-up techniques. *J Phys Educ Sport*. 2020;
- [29]. Ruíz AAB. Sports Biomechanic [Internet]. Vol. 3. 2015. 54–67 p. Available from: <http://repositorio.unan.edu.ni/2986/1/5624.pdf>
- [30]. Batista A, Garganta R, ávila-Carvalho L. Strength in young rhythmic gymnasts. *J Hum Sport Exerc*. 2017;
- [31]. Tringali C, Brivio I, Stucchi B, Silvestri I, Scurati R, Michielon G, et al. Prevalence of a characteristic gene profile in high-level rhythmic gymnasts. *J Sports Sci*. 2014;

- [32]. Di Cagno A, Baldari C, Battaglia C, Guidetti L, Piazza M. Anthropometric characteristics evolution in elite rhythmic gymnasts. *Ital J Anat Embryol.* 2008;
- [33]. Tournis S, Michopoulou E, Fatouros IG, Paspatis I, Michalopoulou M, Raptou P, et al. Effect of rhythmic gymnastics on volumetric bone mineral density and bone geometry in premenarcheal female athletes and controls. *J Clin Endocrinol Metab.* 2010;
- [34]. Galetta F, Franzoni F, D'Alessandro C, Piazza M, Tocchini L, Fallahi P, et al. Body composition and cardiac dimensions in elite rhythmic gymnasts. *J Sports Med Phys Fitness.* 2015;
- [35]. Mawase F, Shmuelof L, Bar-Haim S, Karniel A. Savings in locomotor adaptation explained by changes in learning parameters following initial adaptation. *J Neurophysiol.* 2014;
- [36]. Kolbe I, Dumbell R, Oster H. Circadian clocks and the interaction between stress axis and adipose function. *International Journal of Endocrinology.* 2015.
- [37]. Stirling AE, Cruz LC, Kerr GA. Influence of Retirement on Body Satisfaction and Weight Control Behaviors: Perceptions of Elite Rhythmic Gymnasts. *J Appl Sport Psychol.* 2012;
- [38]. Soric M, Misigoj-Durakovic M, Pedisic Z. Dietary intake and body composition of prepubescent female aesthetic athletes. *Int J Sport Nutr Exerc Metab.* 2008;
- [39]. He C, Trudel P, Culver DM. Actual and ideal sources of coaching knowledge of elite Chinese coaches. *Int J Sport Sci Coach.* 2018;
- [40]. Álvarez O, Falco C, Estevan I, Molina-García J, Castillo I. Psychological intervention in a rhythmic gymnastics team: A case study. *Rev Psicol del Deport.* 2013;
- [41]. Cavallerio F, Wadey R, Wagstaff CRD. Understanding overuse injuries in rhythmic gymnastics: A 12-month ethnographic study. *Psychol Sport Exerc.* 2016;

Developing Assessment Model of a Tennis Forehand Stroke as Biomechanics Movement Perspective

Ricko Irawan¹, Agus Raharjo², Lulu April Farida³
 {rickoirawan33@gmail.com¹, agusraharjo@mail.unnes.ac.id², lulu.farida@mail.unnes.ac.id³}

Universitas Negeri Semarang, Semarang, Indonesia¹²³

Abstract. The wrong biomechanic motion was allegedly made the results of the blow not optimal to the tennis player. The problem of this research is the absence of test instruments and biomechanical motion measurement forehand stroke techniques. The purpose of this research is to make an assessment instrument refers to the movement of biomechanics forehand stroke techniques. The method used in this study is Research and Development. The data used qualitative and quantitative data. The research instrument developed was the FED-0.5 assessment instrument. The results of the study regarding the suitability of the product of the 5 developed test items, namely: 1) foundation = 83.3% very high, 2) rotation = 83.3% very high, 3) position of strength = 75% good, 4) impact = 91.7% very high, and 5) followthrough = 75% good. Conclusion that the 5 instrument products can be used in the development of biomechanical motion assessment forehand stroke techniques.

Keywords: biomechanics of motion, instruments, achievements

1 Introduction

Perfection in playing tennis becomes the main goal in obtaining desired achievements. like a building, the blow technique is the main foundation in the development of other aspects such as physical, tactic and mental. when the player's technique is correct, it will affect the sustainability of the player's achievements, because seen from the biomechanics of the motion, the player who has the correct technique will make the movement more effective and efficient. effective movement will produce explosive power but the energy expended is relatively smaller.

The achievement of tennis players who are "stuck" frustrates many players. This was identified because the mastery of the tennis player technique was not optimal. Improper mastery of techniques causes injury to the player. So that it will inhibit the talent and potential of athletes in developing their achievements. Injuries in tennis are various types such as shoulder injuries, back injuries, elbows, knee injuries, ankle injuries and so forth. According to RSON during 2015 in Indonesia the average incidence of injuries in tennis was 6.3% [1].

One of the basic techniques of tennis blows is the forehand, the forehand is one of the earliest hits controlled by the majority of players than the other techniques.

Forehand is the main basis for playing tennis [2]. The key to a perfect forehand is to develop an aggressive initial approach [3]. A large punch speed will produce a hard punch or a large force [4].

The perfection of the forehand technique is important so that the player can perform as much as possible and of course prevent the body from injury. Results of field observations and interviews with Central Java PON trainers. Enrico Satria said "many players are hampered by their achievements due to injuries, injuries caused by excessive stress and trauma during matches such as the result of knees that often make rounds on forehand blows". [5] concluded that tennis players experience psychological distress and stress directly related to wrist injuries, and sprains.

Seeing the facts above, the researcher concludes that in making forehand movements, it must be done with perfect biomechanical movements, but there are no instruments and parameters for the assessment of biomechanical movements of forehand techniques for advanced athletes / specific achievements so as to cause athlete punches to be ineffective and not optimal. This is a problem for the majority of trainers to develop an instrument of motion assessment for biomechanical forehand, it is important to make an assessment instrument to create high-tech athletes and athletes who are not susceptible to injury.

1.1 The Novelty of Researches Result

This study was designed on the basis of previous researches, the following were previous researches became a benchmark in designing this study:

1. Kamal Firdaus Research in the Journal of Indonesian Sports Science Media in 2011 with the title Evaluation of the Field Tennis Sports Development Program in the city of Padang. This study aims to evaluate the selection of athlete acceptance selection [6].
2. Beni Agus Prasetyo (2018) The results of this study produce a test of the skills of a tennis player [7].
3. Panchal (2019) produced an evaluation instrument for biomechanical dissection and cervical anterior (ACDF) in treating symptomatic disc degeneration, segmental instability and trauma to the cervical spine [8].
4. Liu (2019) produced a multilevel ACCF performance improvement assessment instrument [9].
5. El Daou (2018) produced a new robot platform development product for testing the hip aspect of biomechanical motion [10].
6. Wang (2018) produced a portable exoskeleton development product for hand rehabilitation for motor repair of all upper limbs and motor recovery in the tag and finger function [11].

From some of the literature studies above then summarized through FGD activities conducted by a research team and 2 field tennis experts and 1 national level tennis coach, then the results of the discussion are packaged into a product of test instruments and biomechanical motion measurement forehand technique.

2 Materials And Methods

The design of this study uses Research and development. The data used in this study are qualitative and quantitative data. The sampling technique uses purposive sampling. The product developed in this research is in the form of developing an assessment instrument with data collection techniques using interviews, observations, questionnaires, tests & measurements and documentation. This research is used in tennis sports that are adjusted to actual technical conditions such as the evaluation of athlete's biomechanics. This study aims to produce a product in the form of an FED-0.5 assessment instrument that is suitable for the level of tennis athlete's needs. Development procedures in this study are: 1) Conduct product analysis, 2) Develop initial product assessment instruments FED-0.5, 3) Expert validation, 4) Product trials and 5) Product revisions.

Trial The FED-0.5 assessment instrument product uses the Sukun Tennis Club athlete, previously a small scale trial was validated by experts in accordance with this field of research. To validate the product to be produced, researchers involved 2 (two) field tennis experts from lecturers and 1 (one) PON tennis court trainer. Variables evaluated by experts include foundation, unit turn, power position, racket lag and followthrough.

Collecting data from experts is done by providing an initial model draft accompanied by an evaluation sheet to the expert. Draff evaluation results from experts in the form of assessments and suggestions for instruments that have been made, are used as a basic reference for the development of the assessment instrument forehand technique.

Trials are conducted to obtain responses and product revisions, so that the final product will be produced in the form of an FED 0.5 assessment instrument that suits the needs of athletes at the level of achievement. This study uses an experimental design as a trial design. The trials are conducted in small group trials and large group trials or field trials. Small-scale trials involving athletes of UKM FIK Unnes, amounting to 10 people, 2-3 meetings and large-scale trials involving Sukun Tennis Club athletes, amounting to 18 people 1 meeting. Researchers after receiving input from experts then carry out product revisions. Revisions were made to improve the product before the final product was used.

The data analysis technique used is the percentage for analyzing and evaluating the developer's subject in assessing the level of eligibility, quality, and product acceptance in the form of data from the foundation, rotation, position, strength, impack and followtrought assessment. Respondents are categorized into three categories, namely: good (Mean Score + 1 sd up), Medium (Mean -1 up to Mean Score + 1), Less (Mean -1 up and down).

3 Result and Discussion

Small-scale product trials are intended to test the feasibility of using the product and get input or suggestions. Targets of small-scale product trials are 2 field tennis lecturers and 1 National level tennis coach. The results of small-scale product trials can be seen in the following table:

Table 1. Expert Evaluation Result

No.	Aspects	Testing parameters	Scales				Total respondens
			1	2	3	4	
1.		Foundation			1	2	3
2.	Biomechanics	Unit turn			2	1	3
3.	Movement of	Power position			3		3
4.	Tennis Fore-	Racket lag			1	2	3
5.	hand Stroke	Followthrough		1	1	1	3
Total				1	8	6	
Percentage				6,67%	53,33%	40%	

Table 2. Expert Evaluation Percentage

No.	Subject	Quality answers	of	Conclusion	Classification	Recommendation
1.	Foundation	83,3		valid	very high	use
2.	Unit turn	83,3		valid	very high	use
3.	Power posi- tion	75,0		valid	high	use
4.	Racket lag	91,7		valid	very high	use
5.	Followthrough	75,0		valid	high	use

The data analysis table in the appendix of the results of filling in the expert's assessment of the suitability of the product with physical test parameters, can be concluded as follows:

Aspect of product compatibility with the aspect of foundation assessment obtained a percentage of 83.3%. Based on predetermined criteria, the aspect of product conformity with aspects of the foundation assessment in the movement of forehand biomechanics has met the very high criteria so that this product can be used.

Aspects of product compatibility with the round assessment aspects obtained a percentage of 83.3%. Based on predetermined criteria, the aspect of product conformity with the aspect of unit turn assessment in the forehand motion biomechanics meets the criteria very well so that this product can be used.

Aspects of product compatibility with aspects of the assessment of the power position in the movement of forehand biomechanics obtained a percentage of 75%. Based on predetermined criteria, the aspect of product conformity with aspects of the assessment of strength positions has met the criteria well so that this product can be used.

Aspects of product compatibility with the racket lag assessment aspect obtained a percentage of 91.7%. Based on predetermined criteria, the aspect of product suitability with aspects of impact assessment in the movement of forehand biomechanics has met the criteria very well so that this product can be used.

The product conformity aspect with the followthrough assessment aspect obtained a percentage of 75%. Based on the established criteria, the aspect of product conformity with the followthrough aspect in the movement of forehand biomechanics has met the criteria well so that this product can be used.

Based on the results of small-scale trials that have been validated by experts, it will be discussed further about the correlation of instrument products with related theories.

The foundation in motion biomechanics before doing forehand techniques, one of which is the truth in doing good and right grip techniques. The most correct grip in the forehand technique is the eastern grip. The right athlete using the grip will help make effective and dynamic movements. In research (Roy T.P, Kiyatno, Siswandari, 2017) concluded that grip has a contribution in the biomotor ability of the forehand technique [12].

The unit turn has a great influence on the biomechanical motion of the forehand stroke technique. The body rotation that is elastic and fast will automatically be able to gather energy to be expended. When a player is going to make optimal lap movements, of course, it is necessary to suggest that the agility is moving and the mindset is fast. (Ismalasari, 2010) suggests that speed of thinking and agility in moving are required to perform the forehand technique [13].

The power position in a forehand is very important, because the position of strength will later differentiate between the athlete's punch from one another. Maximum strength must be done properly and correctly. Starting from the shoulder position, chin position, hands that do not hit and the position of the body and elbows must perform its function correctly and in a regular series of movements. (La Sawali, 2018) to get the maximum forehand results must be done with a regular series of motion [14].

When a racket hits the ball or is often called an impact ball, the impact must be done at perfect momentum. The better the momentum, the better ball will be produced. The speed, direction and consistency of a good ball depends on the impact made by an athlete. The correct impact is the eyes focus on the ball, the racket face is slightly horizontal and body weight is channeled forward through the bent left knee (if the player is right-handed) and the ball's shooting distance is not too far from the body. (Palmizal, 2011) when the ball is not too tight and not too far away so the hands are straight. This will affect the balance and control of the ball [15].

4 Conclusion

In the validation trials that have been done by 3 field tennis experts, that product suitability for the test instrument and biomechanical motion measurement forehand techniques can be accepted which include: foundation, turn unit, power position, racket lag and followthrough.

Acknowledgements

We would like to thank Faculty of Sports Science, Universitas Negeri Semarang, Indonesia for the funding.

References

- [1] Supartono B. Karakteristik Cedera Pada Kompetisi Olahraga Cabor Tennis, Sepeda Gunung, Sepakbola, Taekwondo Dan Karate.
- [2] Akhiruyanto A. Model Pendekatan Mini Tennis Dalam Pembelajaran Pukulan Forehand Drive Untuk Perkuliahan Tennis Lapangan. *J. Penelitian Pend.* 2010;27(1).
- [3] Douglas CP, Dorland CC, inventors; Hewlett Packard Development Co LP, assignee. Method and apparatus for monitoring a network. United States patent US 7,975,043. 2011 Jul 5.
- [4] Gunawan A, Sahadevan S, Neuhoff C, Große-Brinkhaus C, Gad A, Frieden L, Tesfaye D, Tholen E, Looft C, Uddin MJ, Schellander K. RNA deep sequencing reveals novel candidate genes and polymorphisms in boar testis and liver tissues with divergent androstenone levels. *PloS one.* 2013;8(5).
- [5] Olmedilla A, Ortega E, Almeida P, Lameiras J, Villalonga T, Sousa C, Torregrosa M, Cruz J, Mas AG. Cohesión y cooperación en equipos deportivos. *Anales de Psicología/Annals of Psychology.* 2011;27(1):232-8.
- [6] Firdaus K. Evaluasi Program Pembinaan Olahraga Tennis Lapangan di Kota Padang. *Media Ilmu Keolahragaan Indonesia.* 2011;1(2).
- [7] Prasetiono BA, Gandasari MF. Model Rangkaian Tes Keterampilan Tennis Lapangan pada Pemain Putra Kelompok Usia 12-14 Tahun. *J. SPORTIF: Jurnal Penelitian Pembelajaran.* 2018 Nov 14;4(2):220-34.
- [8] Panchal R, Gandhi A, Ferry C, Farmer S, Hansmann J, Wanebo J. A Biomechanical Evaluation of a Next-Generation Integrated and Modular ACDF Device Possessing Full-Plate, Half-Plate, and No-Profile Fixation Iterations. *Global Spine Journal.* 2019 Dec;9(8):826-33.
- [9] Liu N, Lu T, Wang Y, Sun Z, Li J, He X. Effects of new cage profiles on the improvement in biomechanical performance of multilevel anterior cervical Corpectomy and fusion: a finite element analysis. *World neurosurgery.* 2019 Sep 1;129:e87-96.
- [10] Daou HE, Ng KG, Van Arkel R, Jeffers JR, y Baena FR. Robotic hip joint testing: Development and experimental protocols. *Medical engineering & physics.* 2019 Jan 1;63:57-62.
- [11] Wang D, Meng Q, Meng Q, Li X, Yu H. Design and development of a portable exoskeleton for hand rehabilitation. *IEEE Transactions on Neural Systems and Rehabilitation Engineering.* 2018 Oct 30;26(12):2376-86.
- [12] Putra RT, Kiyatno K, Siswandari S. Biomotor and Psychomotor Dominant Factors Analysis Determinants of Tennis Groundstroke Forehand Ability on Tennis Achievement Coaching of Students of Fkip Universitas Sebelas Maret, Indonesia. *European Journal of Physical Education and Sport Science.* 2017 Mar 17.
- [13] Ismalasari R, Wibowo S. Pembinaan Olahraga Tennis Lapangan Ditinjau dari Aspek Biomekanik dan Kinesiologi.
- [14] Sawali L. Drills forehand training strategy on the stroke of forehand drive ability in tennis. *International journal of physical sciences and engineering.* 2018 Jun 19;2(2):11-20.
- [15] Palmizal A. Pengaruh metode latihan global terhadap akurasi ground stroke forehand dalam permainan tenis. *Media Ilmu Keolahragaan Indonesia.* 2011;1(2).

The Correlation between Wind Direction and Wind Speed with The Landing Accuracy Result on Paragliding Athletes

Sahri Sahri¹, Nanang Indardi², Nur Amin³

{sahri@mail.unnes.ac.id¹, nanangindardi@mail.unnes.ac.id², nuramin@unw.ac.id³}

Universitas Negeri Semarang, Semarang, Indonesia¹²

Universitas Ngudi Waluyo, Semarang, Indonesia³

Abstract. Paragliding is one of the extremes sports. One of the contested categories is landing accuracy. The purpose of the research is to know the relationship between wind direction and wind speed due to the result of the landing accuracy of athletes. This type of research includes crosssectional by using a total sampling technique in 61 paragliding athletes. Determinants of wind direction and wind speed measurements conducted when the athletes made the landing. The measurement of landing accuracy measures at the first foot on the ground. The results show that the wind direction was associated with the result of landing accuracy ($p=0,02$). While the wind speed is not related to landing accuracy ($p=0,12$), it concluded that the landing accuracy result could influence by wind direction.

Keywords: wind direction, wind speed, landing accuracy, paragliding.

1 Introduction

Paragliding is the sport of free-flying using a parachute by starting to take off on foot. Paragliding by some people occupied with the aim of recreation or achievement. The association of this sport in Indonesia is FASI (Federation of Aero Sport Indonesia). Paragliding takes off from a hillside or mountain and takes advantage of the wind. The wind used as a lifting power, which then causes the parachute flies high in the air. The flight mechanism consists of two kinds, namely, dynamic lift, that is the rising wind that hits the slope and thermal lift that is the rising wind caused by thermal [1]. By making use of both sources, the pilot can fly high and reach great distances. The most interesting is that all applied without using a machine, only solely making use of the wind [2].

Some contested categories in paragliding accuracy of landing, cross the country open distance, and race to the goal [3]. One additional contested category in Indonesia is tandem accuracy, which is flying carrying passengers and landing at a determined point. In recent years, contestant pilots have increased significantly. This can be seen from the number of participants participating in paragliding championships held in all regions of Indonesia on landing accuracy numbers.

In the landing accuracy category, several factors can affect the results. One of them is the wind factor. When flying, athletes make use of the direction and speed of the wind to regulate the high and low position of the fly and the speed of the parachute. Not only the direction and speed of the wind, the strength or magnitude of the wind will also affect the athlete's ability to raise or lower his flight position. Even so, if an athlete makes a landing at high wind speeds, there is a considerable risk of being dragged when landing near the point [4]. In the championship of landing accuracy number, some accidents often occur, one of the accidents is when the athlete makes a landing [5,6,7]. This happens due to many factors, such the athletes to impose to make lower altitude, landing not conformed to the direction of the wind (cross-wind/tailwind), wind speed, athlete's concentration, etc.

2 Method

This research is the correlational descriptive research using total sampling techniques of 61 paragliding athletes. Athletes fly using the main parachute that suits to the athlete's weight capacity, spare parachute, harness, helmet, communication radio, and shoes. All flights supervised by a safety officer who is responsible for activities. Take off is regulated by launch marshal who regulates flight distance, recommends wind speed (0-15 knots), and proper wind direction (direct wind towards the cross-wind hill for senior athletes) and check flight equipment [8,9]. Landing is assessed by the judge, who measures the results of landing accuracy and determine the athlete's fall (get a maximum value of 500 cm) or not. The instruments and measuring methods used in this study are:

2.1 Measurement of Wind Speed and Determination of Wind Direction

The tool used is a windmeter. Measurements are made at several points around the landing place just before the athlete makes a landing. The unit of wind speed is m/s or knots. The tool used is a windsock. Determination of wind direction applied by placing windsock at several points around the landing site and wind direction is determined just before the athlete makes a landing. The wind direction categories used in this study are: East, southeast, south, southwest, west, northwest, north, and northeast. As for the term wind direction flight can be categorized in headwind, crosswind and tailwind [10,11].

2.2 Measurement of Landing Accuracy Result

The tool used is a dead center disc with a digital system whose results displayed on the screen (measuring radius 0-22 cm) and gauge (measuring radius 22cm-499cm) conducted by a certified judge. Measurements took when the athlete landed, and what measured is the first stepping foot touching the ground. If an athlete lands by doing fall (landing on the landing area or harness hits the ground), the athlete will get a maximum score of 500cm [12].

2.3 Data Analysis

Secondary data and data obtained from the results of measurements of wind speed, determination of wind direction, and landing accuracy were analyzed univariate to describe primary data to determine the frequency of all variables and facilitate further analysis. A bivariate analysis then performed using Spearman's correlation test, which aims to determine the correlation between each variable. The analysis results are said to be related if the test results show a significance value of $p < 0.05$ and said to be unrelated if the test results show a significance value of $p > 0.05$. [13]

3 Result and Discussion

The subjects in this study were paragliding athletes with an age range of 16-45 years, with an average age of 29 years. The age range far adrift is due to there is no age limit to conduct paragliding. Unlike some sports in general, the requirement to participate in paragliding championships is for the athlete to pass the exam to get a pilot license. The average respondent in the study was a licensed PL-1 (Pilot License). In paragliding, license categories qualify into PL-1, PL-2, PL-3, and for commercial pilots (master tandem), namely T-1, T2, and T-3. However, at the time of the championship by the safety officer, the participant category was distinguished between juniors (PL-1) who considered to be able to master the basic paragliding and senior techniques (PL-2 AND PL-3) who had mastered advanced techniques (mid and high techniques). At the time of research, wind direction at the flight location tends to blow from the southeast with an average wind speed of 6-10 knots. A general description of the characteristics of research subjects can be seen in table 1.

Table 1. Overview of Characteristics of Research Subjects

Characteristic	Landing Accuracy Results (4.01 + 176.14) (N=61)						Amount		p-value
	0-22		23-499		500		n	%	
	n	%	n	%	N	%			
Age (29.06 ± 9.09)									
<20	1	1.6	2	6.6	9	14.8	12	19.7	0.37
20-35	4	6.6	8	13.1	19	31.1	31	50.8	
>35	0	0	3	4.9	15	24.6	18	29.5	
Gender									
Male	5	8.2	12	19.7	38	62.3	55	90.2	0.43
Female	0	0	1	1.6	5	8.2	6	9.8	
License									
Juniority	2	3.3	9	14.8	32	52.5	43	70.5	0.23
Seniority	3	4.9	4	6.6	11	18	18	29.5	
Wind Direction									
East	3	4.9	4	6.6	8	13.1	15	24.6	0.02*
Southeast	2	3.3	9	14.8	28	45.9	39	63.9	
South	0	0	0	0	2	3.3	2	3.3	
Southwest	0	0	0	0	0	0	0	0	

West	0	0	0	0	0	0	0	0	
Northwest	0	0	0	0	0	0	0	0	
North	0	0	0	0	1	1.6	1	1.6	
Northeast	0	0	0	0	4	6.6	4	6.6	
Wind Speed (7.42 ± 2.91)									
0-5.9	1	1.6	6	9.8	11	18	18	29.5	
6-10.9	4	6.6	7	11.5	24	39.3	35	57.4	0.12
11-15	0	0	0	0	8	13.1	8	13.1	

Correlation test using the Spearman's Test
Significant at the 0.05 level indicated by notation *

3.1 The Correlation between Wind Speed with Landing Accuracy

Table 1 shows that there is no significant the correlation between wind speed and the accuracy of landing results ($p = 0.12$). This was because before the subjects did flight, it determines in which wind speed some are allowed to do the flight, that recommended by launch marshal. It means when taking off and landing, the subject was in a relatively safe wind speed condition and would be easy to control the parachute [13]. The recommended wind speed for flight is 0-15 knots.8 Wind speed is one of the factors that must be considered by safety officers and launch marshal in providing flight recommendations due to frequent accidents during take-off or landing caused by wind speed [14]. So that athletes can avoid the risk of flight accidents [15].

3.2 The Correlation between Wind Direction with Landing Accuracy

Table 1 shows a significant between wind direction and landing accuracy ($p = 0.02$). The ability of subjects to read the direction of the wind and direct the parachute in the same direction of the wind, which could make the parachute easily controlled during landing, could help them get good landing accuracy. Indonesia has two global winds, namely the east monsoon in April - September and the west monsoon in October - March [16]. Which are used as the basis by aerospace sports activists to determine the feasibility of a training ground [17,18]. Beside chief judge who always reports the condition of the wind when it changes, athletes are also required to be able to read the direction of the wind by looking at the windsock when flying [19]. So that athletes can make decisions precisely from which direction they should land and can minimize accidents due to hard landing.

4 Conclusion

It can conclude that the wind direction influenced landing accuracy; otherwise, the wind speed did not influence the accuracy of landing accuracy. The ability of athletes to read wind direction during landing is a crucial factor in getting good landing accuracy results. Suggestions for the future need to research the physical condition of athletes that support in getting good landing accuracy results.

Acknowledgment

The researcher is thankful to the paragliding athletes in Central Java, Indonesia, who had been willing to become research subjects. Also, thanks to the Central Java paragliding trainer and management team who have given research permission. Beholden to Enumerators and judges who have assisted the research process. Moreover, Universitas Negeri Semarang that have helped with funding so that this research can run well.

References

- [1] Panayiotis, K. Guide to Paragliding. Glyfada Athens Greece: Pocket Aviation™; 2012.
- [2] Rzucidlo A. Thermals Map – Assist Flight System. International Book Series “Information Science and Computing. 2009; 13: 85-88.
- [3] Whittall N. Paragliding The Complete Guide Revised & Update. New York: The Lions Press; 1995.
- [4] Vargas M, D.Wang. Paragliding Site Selection an Development – The Basic. Taiwan: USHPA; 2009.
- [5] Schulze W, Richter J, Schulze B, Esenwein SA, Buttner-Janz K. Injury Prophylaxis in Paragliding. Br J Sports Med. 2002; 36: 365-369.
- [6] Feletti F, Goin J. Accidents and Injuries Related to Powered Paragliding: A Cross-Sectional Study. BMJ Open. 2014; 4: 1-7.
- [7] Atreya A, Kanchan T. Analysis of Paragliding Accident – A Preliminary Investigation from Nepal. Nepal Med Coll J. 2016; 18(1-2): 5-8.
- [8] Pagen D. Understanding The Sky. Illustrated Ed. United States of America: Sport Aviation Pubns; 1992.
- [9] Guoxi H, Shuguang Z. Research on Assessment Indicates of Safety and Comfort for Flight in Wind Fields. International Symposium on Aircraft Airworthiness. Elsevier Ltd. 2011; 17: 104-116.
- [10] IVAO. Crosswind and Headwind Calculation. International Virtual Aviation Organisation. https://mediawiki.ivaoo.aero/index.php?title=Crosswind_and_Headwind_calculation
- [11] Van Es GWH, Karwal AK. Safety of Tailwind Operations. Netherland: National Aerospace Laboratory; 2001.
- [12] FAI. Section 7C-Class O Paragliding Accuracy. Switzerland: Federation Aeronautique Internationale; 2019.
- [13] Uyanto SS. Pedoman Analisis Data Dengan SPSS Edisi 3. Yogyakarta: Graha Ilmu; 2009.
- [14] Vargas M. Introduction A Training Manual and Study Guide for Beginner and Notice Level Pilot. Taiwan: USHA; 2008.
- [15] Scott D, Lemieux C. Weather and Climate Information for Tourism. Procedia Environmental Sciences I; 31 August-4 September; Geneva: Elsevier; 2010. 146-183.
- [16] Dia HP, Suparman S, Widhiyanuriyawan D. Pemetaan Potensi Energi Angin di Perairan Indonesia Berdasarkan Data Satelit QuikScat dan WindSat. Jurnal Rekayasa Mesin. 2016; 7(2): 95-101.
- [17] Falavarjani NG. Wind to Select The Recreation Flying Site. International J. of Geograph. and Geo. 2015; 4(3): 57-67.

- [18] Fatkhuroyan, Wati T, Kamid A. Karakteristik Angin dan Take Off dan Landing Pesawat. Prosiding Seminar Nasional Fisika; 29 Juni; Jakarta. ResearchGate; 2018. 85-91.
- [19] Jovanovic V, Njegus A. The Application of GIS and Its Components in Tourism. Yugoslav J. of Operations Research. 2008; 18: 261-272.

Exercising in Urban Environment during COVID-19 Pandemic

Said Junaidi
{said.ikor@mail.unnes.ac.id}

Universitas Negeri Semarang, Semarang, Indonesia

Abstract. During Covid-19 pandemic, people were expected to implement health protocols, one of them was by exercising to increase body immunity. This study aims to analyze sports activities during Covid-19 pandemic. The researcher used a quantitative descriptive. The subjects were urban people aged 12-55 years. The results of the study are 1) During covid-19 pandemic, sports activities are quite good (83%), 2) Women are more active in exercising than men (53%). 3) The age of people who actively exercise is around 12-35 years (66.7%). 4) The frequency of exercising done once a week is 37.7% and the sports activities carried out more than 3 times a week is 38%. 5) Duration of doing sports is around 15-30 minutes (50.6%). 6) The types of exercise that popular are walking (30.3%) and jogging (55%). It can be concluded that sports activities in urban communities during covid-19 pandemic are included in the good category.

Keywords: exercise, urban environment, covid-19

1 Introduction

During the corona virus disease pandemic 2019 (covid-19), almost all people experienced high concerns. Concerns occur not only in urban communities but also in rural communities. Until now, no vaccine has been found that can stop the rate of transmission of the corona virus. Covid-19 is a new disease that has become a pandemic in various parts of the world. This disease must be suspicious because the rate of its transmission is relatively fast. It has a mortality rate that cannot be underestimated and there is no definitive therapy or medical treatment that can help to manage the disease. In addition, there are still knowledge gaps dealing with this corona virus, so then further studies are needed [1]. Efforts that can be done are as much as possible to avoid the risk of transmission of the virus through the application of health protocols. The goal is actually to minimize the risk of infection through an increase in a healthy lifestyle, one of which is to exercise regularly and safely.

Various non-infectious diseases that have emerged in the midst of society, one of which is caused by the habit of exercising does not become part of the daily lifestyle. A relatively passive lifestyle will cause physical weakness as a result of

hypokinetic. Hypokinetic causes rapid weakness in physiological functions due to degenerative processes. This causes the work productivity to be decreased or disrupted and even very likely to be stopped. The habit of exercising is expected to become the needs of the community as well as the need for drinking and eating. Regular and programmed exercise will have a positive impact on health / fitness as well as people's growth and development. In addition, it can also have a positive impact on body health and fitness which can then have an effect on increasing work productivity as well. Moreover, doing sports activities can also reduce / slow the occurrence of degenerative processes for the elderly.

Government agencies and NGOs around the world are increasingly aware of the role of sports in filling leisure time with doing some physical activities that can reduce barriers and social strife as well as reduce violence in society [2]. A number of international sports researchers and humanitarian agencies suggest that the positive impact of sport is a need to improve individuals, cultures, and societies [3]. The United Nations through the charter of resolution 58/5 of 2003 states that sport is an effective media as a tool to show the strength of the nation in the international community [4].

Sporting activities is the intentional use of sports, physical activity, and games to achieve the specific development goals of a nation [5]. Sport has been able to be an important part of the process to achieve the goals of fostering physical fitness, growth and development of movement, mental, moral, attitudes, and behavior in accordance with the noble values of the nation. Even John Fitzgerald Kennedy, the 35th President of the United States, once said that fitness is the basis for all other forms of excellence. Development of physical fitness and health contribute to the effectiveness of life and enjoyment of life [6].

The results of a research in Sweden concluded that exercise as a tool for the development of adolescents towards a positive direction. There is evidence of a correlation between sports involvement and self-esteem, sharpening physical competence, social competence [7]. Sport is able to unite differences in race, religion, ethnicity, gender as well as a reliable drug to cure social ills [8]. Sports activities can shape the character, knowledge and skills of the community to be more positive, including teenagers and young people.

The results showed that sports participation in a South African city was able to develop youth competencies including enhancing self-concept, discipline, and skills. Furthermore, in India, Kay found that sports-based programs designed to promote leadership in adolescent women can help increase knowledge. Thomson, Darcy and Pearce conducted several case studies of sports programs designed to reduce social injustice that existed between indigenous peoples and Australians. The Hokowhitu Program is an example of a sports-based youth development program targeted at Maori youth. The program has succeeded in generating a positive attitude towards schools, improving skills, and a more optimistic outlook [9].

The importance of examining the relationship between sports participation and morality to determine whether the level of sports participation is related to morals, aggressive tendencies, and judgments about the legitimacy of sporting actions [10]. The results show that there is a positive effect when teenage girls engage in sports or enjoyable physical activities, when they engage with friends, and when they are supported by family and teachers through role modeling and positive feedback [11]. The

problems of low trends in community for exercising are, first; There is still a lack of research on the relationship between goal orientation and motives for participating in sports and physical activities [12].

Second, lack of attention about physical activities patterns and health implications related to immovable behavior so it is important to better understand the dynamics of physical motivation of young people. Third, physical education (including sports) has become an important aspect. The tendency of urban communities to have a decreased movement culture will cause a setback in fitness and physical capacity.

The results of Sylejmani's, Blerim. et al. show that children and adolescents from rural environments have better results in cardiorespiratory fitness, upper muscle fitness, lower extremities, coordination, speed, and agility compared to those who live in urban areas [13].

The behavior of urban communities in Indonesia related to exercise habits tends to decrease. Cyberspace-based advancements in digital and automatic-electric technology have made urban communities given so much convenience. However, during the Covid-19 pandemic there were indications that people had increased awareness about the importance of exercise to enhance their immunity. Prevention of the spread of the corona virus through increased self-defense (immune response) can be done by exercising.

Other prevention are to increase endurance through intake of healthy food, frequent hand washing, wearing masker, doing exercise, getting enough rest, and eating well-done food [14]. When getting sick, immediately seek treatment to the referral hospital for evaluation. The implication for policy is that cross-sectoral initiatives between sports, social and health need to be supported because the effects are directly related to each other [15].

2 Method

This study belonged to a descriptive quantitative research. It aimed at analyzing the urban community who exercised during covid-19 pandemic within the perspective of gender, age, frequency, intensity categories, duration, and type of exercise. The population used was a large city community with a range of age from 12 years to 55 years old. Incidental cluster sampling technique was used to determine the subject of the study. Questionnaire and structured interviews were used as a method in collecting the data. The questionnaire was spread via Google Form. The validity of the instrument used is internal validity with the construct validity approach [16]. The research data were analyzed in a narrative and descriptive quantitative and displayed by using percentage approach.

3 Results And Discussion

During the establishment of the covid-19 pandemic status by the Indonesian government, people in most regions in Indonesia tended to have high anxiety and panic. This is caused by several factors such as the rapid rate of transmission of the

virus, the coronavirus vaccines is still unavailable, and the death rate caused by covid-19 that cannot be underestimated. Transmission that occurs in large cities is relatively greater than in regions with smaller areas. The number of positive people with covid-19 in big cities in Indonesia during 2020 is relatively high.

This then requires the community to actively participate independently to take steps to prevent transmission by implementing health protocols. According to the health protocol, the public is expected to be able to do safe sports to improve fitness that can increase body immune so that it can ward off the corona virus effectively.

This research begins by determining an area that is a major city area and then observing sports activities carried out by people in the region. The division of regions is based on the smallest unit of territory consisting of villages and then developed into districts. The number of sub-districts in this study were 177 sub-districts within 16 districts with an overall area of 373.7 KM² (<https://semarangkota.bps.go.id>). The population of the big cities in this study was 1,668,578 people spread in 16 districts and 177 sub-districts

The results of this study show that the number of urban communities engaged in physical activities over the period of one week was 83%, while 17% of the people did not do physical activities. Furthermore, as many as 53.3% of the people who like to exercise are female while 46.7% are male.

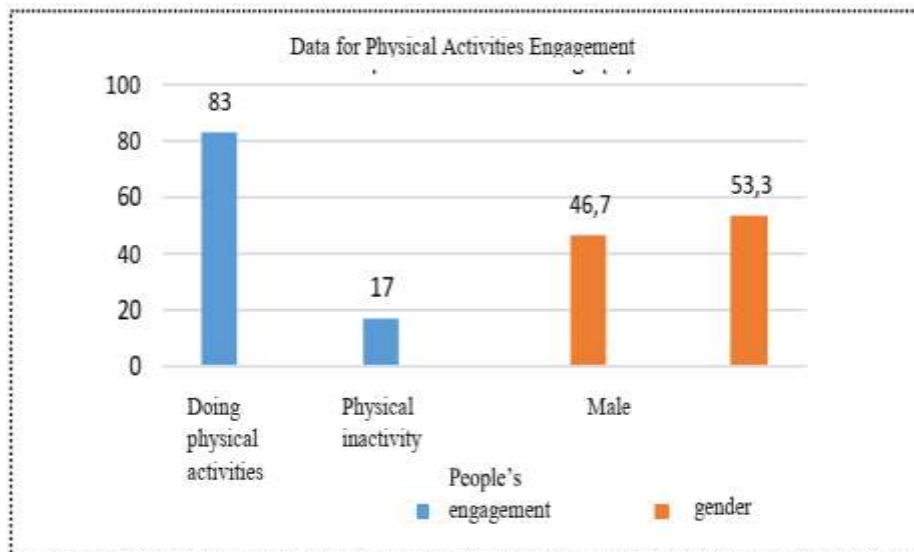

Fig. 1. Data for People's Engagement on Physical Activities based on Gender

Next, a description of the average age of urban people who love doing exercise. Based on the results of the study it was found that as many as 87.5% people aged 12-35 years, 11.7% people aged 36-55 years, and 0.8% aged over 55 years.

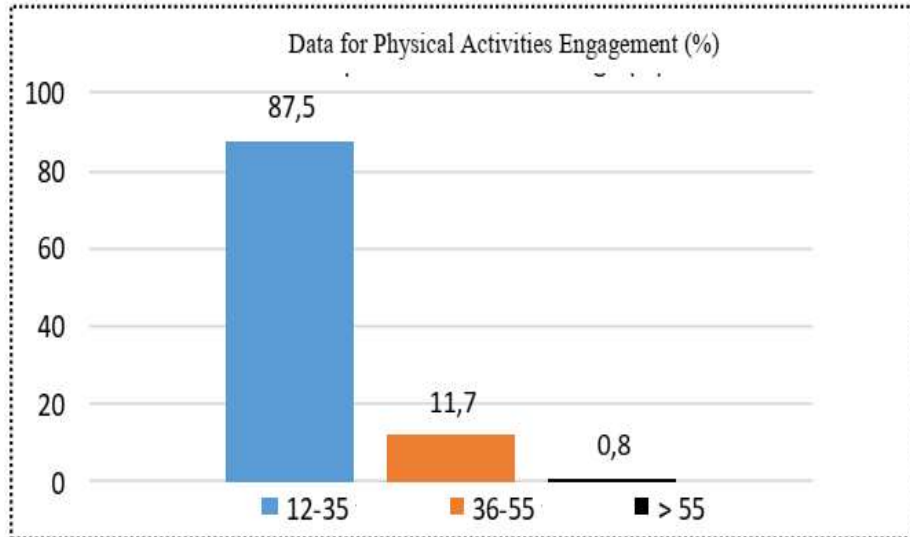

Fig. 2. Data for People's Engagement on Physical Activities based on Age Group

Based on research data, it is known that 17.5% people who love doing exercise work as civil servants / Soldiers / Police / Private Employees. As many as 15.8% are self-employed and the rest 66.7% are students.

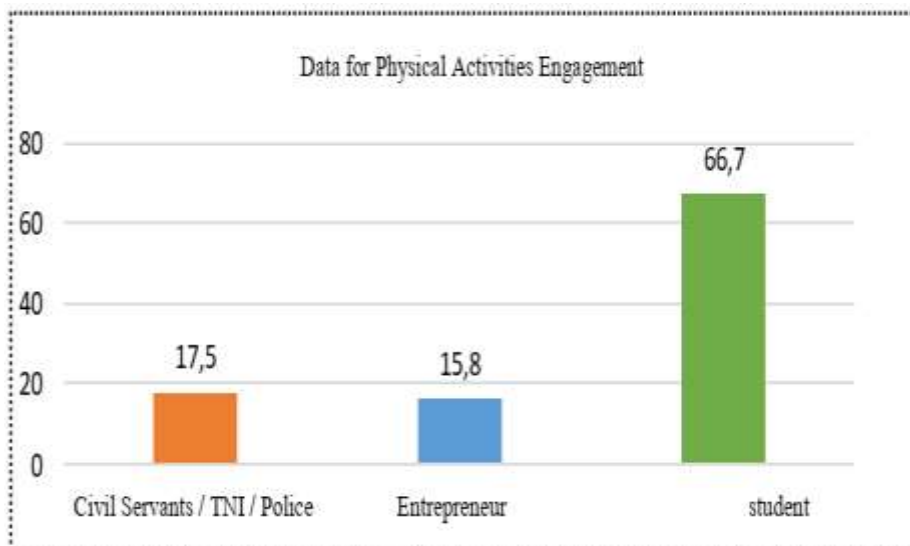

Fig. 3. Data for People's Engagement on Physical Activities based on Occupation

According to AAHPERD (1999) there are four principles in exercise that can have an impact on changes in fitness, namely FITT (frequency, intensity, time, and type). The frequency of urban communities in doing sports based on research results is that as many as 37.7% people do exercise once a week. Whereas 24.3% of people do exercise two times a week, and 38% of people do exercise more than three times a week.

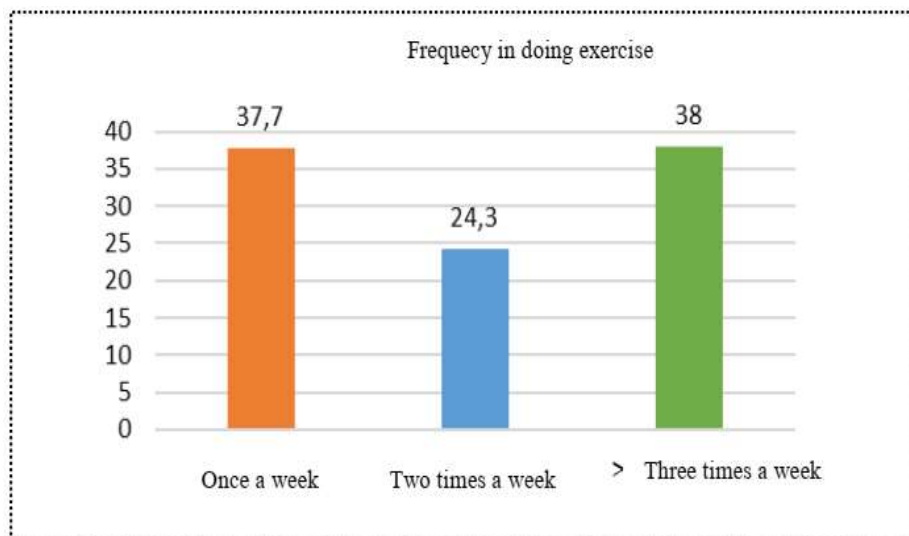

Fig. 4. Data for People's Engagement on Physical Activities based on Frequency

The intensity in exercising is an important factor in determining fitness. But to determine how much the intensity of the exercise is not easy because it must go through a pulse calculation (heart rate). The intensity in this research data is informative and is not based on real measurement because it is obtained only through questionnaire.

Therefore, the category in question is exercising with a perceived burden that is "light, moderate, and vigorous". Based on information from respondents, 52.6% of people stated that they did some light exercises, while 39% of people said they did moderate exercises and 8.4% of people uttered that they did some vigorous exercises.

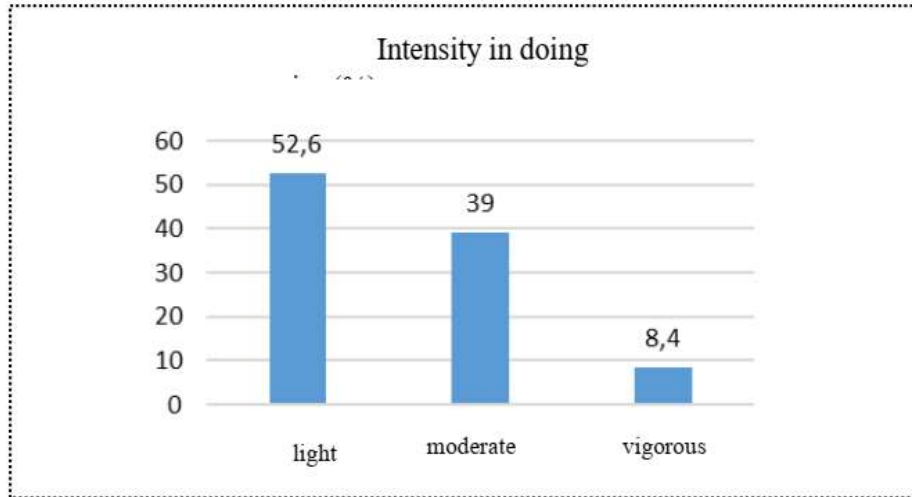

Fig. 5. Data for People's Engagement on Physical Activities based on Intensity

The duration of time in doing exercise is an important factor in providing a physiological effect of exercise. The difference in the amount of time when doing sports will have a different impact on the body. As an illustration, jogging in a relatively long period of time without stopping is included in the low intensity category and gives an effect on general endurance (endurance).

According to information from respondents that 13.6% of respondents did exercise less than 15 minutes. Most or as many as 50.6% of respondents did exercise between 15-30 minutes. Then as many as 35.7% did exercise in a period of more than 30 minutes.

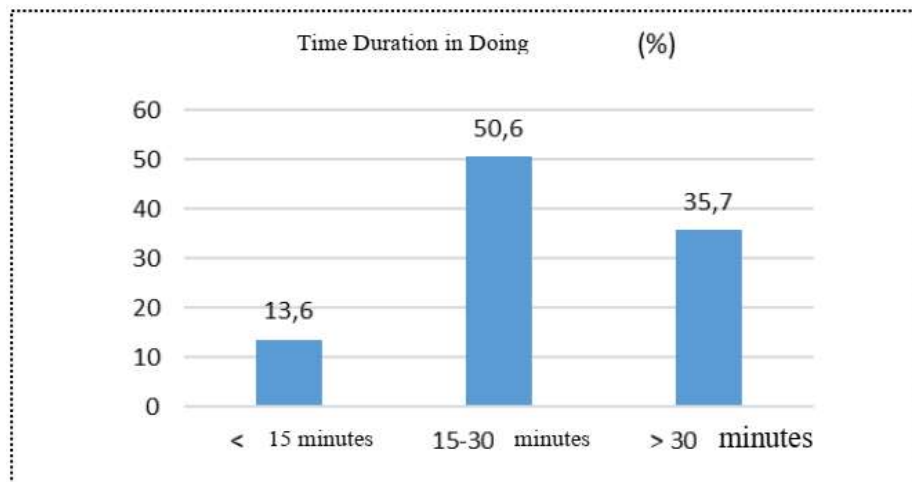

Fig. 6. Data for People's Engagement on Physical Activities based on Time Duration

Exercises carried out by urban people is one indicator of the model of community involvement / participation on the importance of maintaining physical fitness through sports. Exercise that is practiced regularly and safely can bring about positive changes and give physiological effects. This study divides the types of exercise such as walking, jogging, cycling, swimming, gymnastics, sports games, martial arts, and others. This study gives respondents the opportunity to choose more than one type of exercise.

This means that there are people who exercise more than one type of exercise so that the total percentage is not 100%. The results showed that 30.3% of respondents go walking, 55% of respondents go jogging, while 33.8% of respondents go biking and 12.7% of respondents go swimming. Meanwhile 12.2% of respondents do aerobics dance, 38.6% of respondents play sports game (soccer, futsal, volleyball, basketball, etc.). Then 6.5% of respondents do martial arts, while 14.7% of respondents play other sports in accordance with their interest. The results of the study show that during the covid-19 pandemic, many urban people begin to realize and practice various physical activities such as doing some sports. This is a positive indicator that active movement is important in terms of improving the quality of life.

Moreover, during the covid-19 pandemic, it requires everyone to live a healthy lifestyle and actively exercise safely to improve the body's immune response. The habit of doing exercise in urban environment based on this research is characterized by an average of above 50% of people actively do exercise. Some exercises are also practiced by people from children to adolescents. More than 50% of urban people do some exercise in accordance with FITT principle (frequency, intensity, time, and type of exercise) so that it is impactful and safe for health.

Healthy lifestyle is one of the efforts to improve health status and quality of life. Among the healthy lifestyle that are expected to be carried out by the people are regular, programmed, and measurable exercise. Sports is recognized as one of the activities that can increase the value of body fitness at all age levels even more so during the covid-19 pandemic. The Lifetime Health Letter reports that men and women aged 65 years or older who walk more than four hours / week are less likely to be treated for heart disease than those who are younger [17].

People's fitness through active living habits in urban areas needs to receive more attention than people in rural / non-urban areas. Changes in the lifestyle of big city communities from active to inactive due to the technology that is completely automatic and electrically makes hypokinetic occur in humans. Diseases arising from lack of movement (hypokinetic) make the quality of health and fitness decrease which impacts on the decreasing quality of the human organ system. Hypokinetic can cause health problems including degenerative / non-infectious diseases [18].

During the Covid-19 pandemic, physical fitness is very important to help improve the immune response which in turn can help ward off the body from being infected by the corona virus. Although there is no good news regarding prevention of covid-19 transmission through vaccines, the application of health protocols is a good alternative for all parties to implement. One suggestion in the health protocol is to exercise safely to improve physical fitness.

4 Conclusion

Based on the results of the study, it can be summed up that people's involvement on physical activities during covid-19 pandemic in urban environment is prone to be well-practiced. Moreover, they relatively implement the fitness training principles to develop their physical fitness as an effort to stay healthy.

Acknowledgements

We would like to thank Faculty of Sports Science, Universitas Negeri Semarang, Indonesia for the funding.

References

- [1] Adityo Susilo, dkk. 2020. Jurnal Penyakit dalam Indonesia Vol. 7, Nb. 1 March 2020. <http://jurnalpenyakitdalam.ui.ac.id/index.php/jpdi/article/view/415/228>. accessed 07/07/20.
- [2] Schulenkorf, N. *Sport for Development Events and Social Capital Building: A Critical Analysis of Experiences from Sri Lanka*. J. of Sport for Develop. March 2013.1(1). p:25.
- [3] Hancock, Meg g, Alexis Lyras, Jae-Pil Ha. *Sport for Development Programs for Girls and Women: A Global Assessment*. (internet) J. of Sport for Develop. March 2013.1(11). p:41. (cited 8/5/2014).
- [4] Hartmann, D et al. *Sport Development: An Overview, Critique, and Reconstruction*. (internet). J. of Sport & Sosial Iss. July.29.2011. 35 (3). p:284.
- [5] Richards, Justin. Kaufman, Zachary. Wolf, Eli. Gannet, Katie. et al. *Advancing the Evidence Base of Sport for Development*. J. of Sport Develop. 2013.1 (1) p: 1-3.
- [6] Buck, Marliyn M. et.al. *Instructional Strategies. For Secondary School Physical Education*. New York. Mc Graw Hill Higher Education. 2007 p.18.
- [7] Wagnsson, Stefan., Christian A., Göran P. *Associations Between Sport Involvement and Youth Psychosocial Development in Sweden: A Longitudinal Study*. (internet). J. of Sport for Develop. March 2013 1 (1). p:37.
- [8] Russel Hoye, Nicholson, M. & Houlihan, B. (). *Sport and Policy*. Elsevier Ltd 2017 (Vol. 91).
- [9] Halsall, T and Tanya Forneris. *Challenges and Strategies for Success of a Sport for Development Programme for First Nations Metis and Inuit Youth* (internet). J. of Sport Develop. 2016. 4(7). p.40.
- [10] Sylejmani, Blerim. Et Al. *Physical fitness in children and adolescents in rural and urban areas*. (internet) J. of Human Sport and Exerc. 2019.14(4). p:866.
- [11] Casey, MM; Eime. RM; Payne, WR; Harvey, JT. *Using a Socioecological Approach to Examine Participation in Sport and Physical Activity Among Rural Adolescent Girls*. Qualitative Health Research Volume XX Number X. 2009. p:1.
- [12] Zahariadis, PN; Hesseloniki, G; Biddle, SJH. *Goal Orientations and Participation Motives in Physical Education and Sport: Their relationships in English School children*. (internet). The Online J. of Sport Psycho.
- [13] Sylejmani, Blerim. Et Al. *Physical fitness in children and adolescents in rural and urban areas*. (internet) J. of Human Sport and Exerc. 2019.14(4). p:866. (cited 29/01/2019).
- [14] Diah Handayani, dkk. (2020: 128) Penyakit Virus Corona 2019. J. Respirologi Indonesia. Volume 40, Nomor 2, April 2020.

- [15] Marlier, Mathieu. et al. . *Interrelation of Sport Participation, Physical Activity, Social Capital and Mental Health in Disadvantaged Communities: A SEM-Analysis*. (internet). Plos One. October 9 2015.
- [16] Eko Putro W. 2016. Teknik Penyusunan Instrumen Penelitian. Yogyakarta. Pustaka Pelajar.
- [17] Widjaja Kusuma. 1999. Bugar Setelah Usia 40. Interaksara. Batam.
- [18] Djoko Pekik I. 2000. Panduan Latihan Kebugaran yang Efektif dan Aman. Lukman Offset. Yogyakarta.

Effectiveness Test of Tools (Wire Steel) toward Forwarding Somersault Skills

Sani Gunawan¹, Fegie Rizkia Mulyana², Ridwan Gumilar³
 {sanigunawan@unsil.ac.id¹, fegierizkiamulyana@unsil.ac.id², ridwangumilar@unsil.ac.id³}

Siliwangi University, Tasikmalaya, Indonesia¹²³

Abstract. This study aims to determine the effectiveness of tool for somersault skills. Another purpose of this research is to be used as teaching material and methods on how to provide assistance effectively and efficiently when teaching gymnastics. The basic thing that underlies this research is to enrich science through research in the field of teaching, especially on the floor gymnastics course. This research uses the Quasi Experiment research method, while the research design uses Nonequivalent Control Group Design. Data analysis in this study used the normality test and homogeneity test, followed by an t-test to test the research hypothesis. From the results of data processing and analysis and hypothesis testing, it was concluded that there is a difference in the results of front somersault skills between the experimental group using wire steel and the control group not using aids but not significantly.

Keywords: effectiveness test, forwarding somersault skills, tools.

1 Introduction

Learning is one of the main imperatives in completing the Tri Dharma of Higher Education. Learning is a combination that is arranged inhumanely, equipment, facilities, procedures that affect each other in achieving learning objectives[1] Besides learning is interpreted as teacher activities that are programmed in instructional design, to make students active learning, which emphasizes the provision of learning resources. Teaching can be viewed from many perspectives. The perspective teachers take when they look at the teaching-learning process determines what they will look at in that process and how they will look at it. Perspectives are important because they cause the teacher to see things in certain ways[2]. Some of the above understanding, can be denied from learning as a process of lecturer perspective in seeing things in a certain way in the process of interaction between students and lecturers and learning resources to exchange information. Learning in physical education is essentially in a learning process that requires physical learning to produce holistic changes, these changes are needed through a theory of motion learning that includes cognitive stages, associative stages, and autonomous stages to achieve physical education goals. The goals of physical education are three psychomotor, cognitive, and affective domains[3].

Learning gymnastics floor, in which there are many obstacles that are often encountered including learning difficulties experienced by students to learn basic techniques to complex techniques, in addition to the lack of courage of students in doing the task of movement[4]. Learning difficulties are conditions that cause obstacles in one's learning process that result in failure in achieving learning goals[5]. When learning the movement skills of students must understand the concept of movement first[6]. If you have not mastered the task of motion that must be done, the lecturer must help until students understand and are able to practice the movement. Another obstacle found in gymnastic learning is the lack of tools to support the safety factor and the provision of assistance during the learning process. In line with the above opinion[7] stated when teaching gymnastics, things to consider are security and safety. In addition, the end result of the teaching process is the high ability of students to be able to learn easily and effectively[8].

In reality in the field, to achieve effective gymnastics learning is not enough to use the method alone. Aids are needed or effective learning media in delivering learning material. Learning aids in the learning process can arouse new desires and interests, generate motivation and stimulation of learning activities, and even bring psychological influence on students. The use of instructional media at the learning orientation stage will greatly assist the effectiveness of the learning process and the delivery of messages and content at the time[9]. Based on research that had been carried out the previous year, researchers tried to develop aids for front somersault skills. The results achieved in previous studies are the creation of aids made from a series of outdoor tools such as carabiners, webbing, pulleys, steel wires, and hardness designed to facilitate the learning process in gymnastics courses. The tool that was created was the result of expert evaluations in the preparation of initial products which were then tested on a limited scale. Limited trials were carried out on 12 subjects namely Physical Education students at Siliwangi University, extensive trials were conducted on subjects as many as 30 physical education students with different classes from small scale pilot classes assuming the subjects came from different schools. The purpose of this development research is to see the effectiveness of the products that have been developed in the previous year for students of Physical Education at Siliwangi University. Effective or not a product, can be seen from student learning activities and student learning outcomes.

2 Methods

The method used in this study is the Quasi Experiment research method. According to [10] the experiment is most powerful quantitative research method for establishing cause and effect relationships between two or more variable. The most commonly used quasi-experimental design in educational research is the nonequivalent control-group design. In this design, reserch participants are not randomly assigned to the experimental and control groups. Experimental research is the most conclusive scientific method. Because the researchers actually set different treatments and then study their effects, the results of this type of research tend to lead to most clear interpretations[11]. Next opinion[12] adding experimental research can be interpreted as a research method used to look for the effect of certain treatments on others under con-

trolled conditions. Quasi experimental design is used because in reality it is difficult to get a control group used for research. The research design used in this study is non-equivalent control group design. This study uses two groups, namely the experimental group and the control group. Both groups were given a pretest. The experimental group was then given treatment using steel wire aids for front somersault skills, while the control group was given conventional learning. At the end of the treatment the researcher conducted a post-test given to the experimental group and the control group. The design of this study is illustrated in the table below,

Table 1. Nonequivalent Control Group Design

Group	<i>Pretest</i>	<i>Treatment</i>	<i>Posttest</i>
Eksperimental	O ₁	X	O ₂
Control	O ₃	-	O ₄

Information :

O₁ : *Pretest* eksperimental group

O₂ : *Posttest* eksperimental group

O₃ : *Pretest* control group

O₄ : *Posttest* control group

X : Learning using tools

The population in this study was the 2017 Physical Education students consisting of 5 classes. The sampling technique uses simple random sampling which is to choose one class that is determined randomly. The class that was sampled in this study was class 1A, amounting to 38 people. Of the 38 samples divided into two groups not chosen randomly, namely 19 people in the experimental group, and 19 people in the control group. The data processed in this study is a test of learning outcomes of front flip skills. The instrument used in this study used a front somersault skill test that had been tested and validated by experts in previous studies. Indicators of front salto skills can be seen in the following table,

Table 2. Front Somersault Skill Instrument

Dimension	Indicator	Score
Prefix	- Perfect stand	
	- Begins by running a few steps	
Implementation	- Resist with both ends of the foot and tight	
	- Both arms are straight and flanking the ears	
	- Refuse to reach the highest point	
	- Roll in the air (head bent, arm holding knees, harmonious rotation)	
Suffix	- After turning 360 ⁰ both hands are released from the knee, legs are straightened and ready to land	
	- Landing with both feet tight	
	- Knees slightly bent	
	- Both hands stretched out to the front side to maintain balance	
JUMLAH SKOR		

Description of the rating scale :

1 poin:

Correct performance; proper mechanics, executed in good form. The performer shows balance, control, and amplitude in motion,

0,75 poin:

Average performance; errors seen in mechanics or form; might indicate a lack of balance, control, or amplitude in motion,

0,50 poin:

Bad appearance; errors in mechanics and form. The performer shows a slight balance, control, or amplitude in motion,

0,25 poin:

Incorrect or nonexistent performance; ignoring mechanics or deformity; there is no display of balance, control, or amplitude in motion.

The data of this study were analyzed quantitatively using statistical analysis techniques, namely using the normality test and homogeneity test. After the results obtained are normal and homogeneous, followed by t-test: Two-Sample Assuming Unequal Variances to test the research hypothesis.

3 Results and Discussion

During the learning process, the lecturer acts as a facilitator and guides the process of using steel wire aids for front flip skills. The lecturer gives instructions related to the task movement that will be carried out starting with conveying the theory and concept of front flip material. After that the lecturer gave a demonstration both in the use of tools and ways to help the movement. During the learning process students enjoy the process and discover learning experiences, with the use of steel wire aids, students are helped in learning the task of motion. The fear of doing complex movements can be overcome with these steel wire aids. The results of interviews with students, the effect of the use of these aids for students, which can increase the will power and motivation of students in learning the front flip movement besides student confidence can be increased because of a belief in safety and comfort in doing the movement. From the learning results obtained data as follows,

Table 3. Learning Outcomes

Group	n	Average	
		<i>Pretest</i>	<i>Posttest</i>
Eksperimen	19	52,63	57,89
Control	19	52,58	54,68

In accordance with the above statement of the writer that learning in physical education, especially learning gymnastics, is essentially a learning process that

utilizes physical activity to produce holistic change. The holistic meaning is related to the learning process so the psychomotor, cognitive, and affective aspects of students are achieved. Achieving goals in the learning process is influenced by innovative and quality learning processes so that students get a meaningful learning experience. It is better for lecturers or instructors to create or provide tools in an effort to accelerate the learning process so that the objectives of the learning process can be achieved properly. The data of front somersault skills obtained were analyzed through normality test and homogeneity test followed by t test: Two-Sample Assuming Unequal Variances, as in the table below,

Table 4. Normality test

Group	n	Var	SD	L_0	L_t	Result
Eksperimen	1	239,43	15,47	0,1285	0,19	Norma
t	9	3	4	1	5	1
Control	1	127,33	11,28	0,1287	0,19	Norma
	9	9	4	7	5	1

From the normality test data above, obtained L_0 count (0.12851) from the experimental group with L_0 table (0.195). L_0 count (0.12877) from the control group with L_0 table (0.195). The conclusion is that the samples in the experimental and control groups are normally distributed. Then the data analysis is continued with the homogeneity test or the F test as in the table below,

Table 5. Homogeneity test

Group	df	Var	F hit	F tab	Result
Control	18	127,339	1,880	0,45102	Homogen
Eksperimen	18	239,433	3		

The results of the F test above, obtained an F count of (1.8803) is greater than the F table of (0.45102), thus it can be concluded that the sample for this study is Homogeneous. After obtaining the value of F, then do the t test: Two-Sample Assuming Unequal Variances with the aim to compare the average of two groups that are not paired with each other or not related to each other, or two different sample subjects. As in the table below,

Table 6. t Test : Two-Sample Assuming Unequal Variances

	<i>Variable 1</i>	<i>Variable 2</i>
Mean	57,89474	54,68421
Variance	239,4327	127,3392
Observations	19	19
Hypothesized Mean Difference	0	
df	33	
t Stat	0,730727	

P(T<=t) one-tail	0,235051
t Critical one-tail	1,69236
P(T<=t) two-tail	0,470103
t Critical two-tail	2,034515

From the results of the statistical analysis of the above hypothesis test, obtained t count (0.730727) < from t table (2.034515) which means that Ho was accepted and H1 was rejected, so it was concluded that there were differences in the results of front somersault skills between the experimental groups using assistive devices with control group that does not use assistive devices but not significantly.

4 Conclusion

Experimental research that has been carried out is a follow-up study from the previous year about the development of tools (steel wire) for front somersault skills. Based on the results of the statistical analysis of the hypothesis test using the t-test, the results of the effectiveness test in this study showed the ineffectiveness of the tools steel wire used for front somersault skills. It is assumed that there are several factors that influence the results of this study, such as being less objective and less consistent in assessing front somersault skills in order to obtain less authentic scores. However, if seen from the results of the pretest and posttest as well as the psychological point of view of students there is an increase in movement skills. In addition, the learning process produces psychological changes, that is, students feel comfortable and safe when using steel wire aids and are able to increase student motivation in learning task assignments. Based on the analysis of the results of the t test results in the experimental group and the control group, it showed that there were differences in the results of the front somersault skills using steel wire aids but not significantly with the t value (0.730727) < from the t table (2.034515).

The results of the research carried out have similarities with other studies namely, such as research results[13] with the results of the pretest and posttest: (a) return board products have effectiveness and can be used to improve forehand for table tennis topspin for beginners 53%, and for advanced groups 32%, (b) return board products can be used as training tools for junior, beginner and senior level table tennis athletes, (c) return board products can be used as a means of motivating athletes to practice by measuring the ability of each athlete's topspin forehand. In line with the results of the above research[14] mention; (a) based on the validation of experts and the results of the trial, a front handspring skill test model product for overall gymnastics athletes is suitable for use (b) based on the results of small group trials, and field trials can be stated that products in the form of front skills tests Handspring is valid and suitable for use. Besides the results of research[15] the creation of a futsal ball thrower that has been tested for effectiveness and serves to hone the capabilities of various futsal ball game techniques. The expected results of research are to help the world of futsal sports in Indonesia so that it triggers the emergence of new technological ideas and tools in the future.

The equation of the research results lies in the product being developed in the form of a tool that is tested for the effectiveness of the product to be used in terms of improving performance, especially in the branch of gymnastics and is beneficial for all people. The difference in results from the research conducted is, in several other studies focus on the development of gymnastic assessment instruments, as well as the development of tools for techniques that are fairly basic in certain sports. The advantage of this research is the creation of tools that can be used to help techniques that are classified as both complex in achievement gymnastics and educational gymnastics. The resulting product is beneficial for teachers, lecturers, and even trainers. However, the results of effectiveness tests in this study need to be reviewed and re-examined for the future by rearranging the product design that was developed, and involving experts or judges when conducting assessments when collecting data in the field.

Acknowledgements

We would like to thank Siliwangi University, Indonesia for the funding.

References

- [1] Hamalik O. *Proses Belajar Mengajar*. Bumi Aksara. Bandung.; 2003.
- [2] Mudjiono D dan. *Belajar dan Pembelajaran*. Rineka Cipta. Jakarta; 2006.
- [3] Rink JE. *Teaching Physical Education for Learning*. The McGraw-Hill Companies, Inc.; 2014
- [4] Buck, M. M., Jable JT. *Introduction to Career in Health, Physical Education, and Sport*. Wadsworth: Thomson Learning.; 2004
- [5] Gunawan, S., Millah, H., & Mulyana FR. Development of Tools for Forwarding Somersault Skills. *J Phys Educ Sport* [Internet]. 2018;7(3):200–7. Available from: <https://journal.unnes.ac.id/sju/index.php/jpes/article/view/26296>.
- [6] Hakim T. *Belajar Secara Efektif. Panduan Menemukan Teknik Belajar, Memilih Jurusan, dan Menentukan Cita-cita*. Jakarta : Puspa Swara; 2001.
- [7] Gunawan, S., Millah, H., & Mulyana FR. Development of Tools for Forwarding Somersault Skills. *J Phys Educ Sport* [Internet]. 2018;7(3):200–7. Available from: <https://journal.unnes.ac.id/sju/index.php/jpes/article/view/26296>
- [8] Hakim T. *Belajar Secara Efektif. Panduan Menemukan Teknik Belajar, Memilih Jurusan, dan Menentukan Cita-cita*. Jakarta : Puspa Swara; 2001.
- [9] Restian A. *Psikologi Pendidikan Teori & Aplikasi*. Malang: UMM. Press.; 2015.
- [10] Ward, Philip & Lehwald H. *Effective Physical Education Content and Instruction*. Human Kinetics.; 2018.
- [11] Hariyanto S&. *Belajar dan Pembelajaran: Teori dan Konsep Dasar*. Bandung: Remaja Rosdakarya.; 2016.
- [12] Hasanah A. *Pengaruh Latihan Alat Bantu Matras Miring Dan Matras Datar Terhadap Hasil Belajar Roll Belakang*. 2016;
- [13] Meredith D. Gall, Walter R. Borg JPG. *Educational Research*. Allyn & Bacon. Pearson Education, Inc.; 2003.
- [14] Fraenkel JR. *How to Design and Evaluate Research in Education*. McGraw-Hill, a business unit of The McGraw-Hill Companies, Inc; 2012.
- [15] Sugiyono. *Metode Penelitian. Kuantitatif, Kualitatif dan R&D*. Alfabeta; 2016.

- [16] Santosa T; S. Pengembangan AlatBantu Return Board Untuk Forehand Topspin Tennis Meja. *J. Pedagog Olahraga* [Internet]. 2016;2(2):30–48. Available from: <https://jurnal.unimed.ac.id/2012/index.php/jpor/article/view/4513>
- [17] Handayani SG. Pengembangan Instrumen Tes Keterampilan Front Handspring Atlet Senam Lantai. *J Sains Keolahragaan Kesehat.* 2018;3(1):23–6.
- [18] Syakur, Mohamad Abdul; Badruzaman; Paramitha ST. Pengembangan Alat Bantu Latihan Pelontar Bola Futsal Berbasis Mikrokontroler dengan Menggunakan Software Pemograman Arduino. *J. Terap Ilmu Keolah.* 2017;2(1):29–32.

The Achievement of Physical Education Learning Objectives during COVID-19 Pandemic

Septian Williyanto
{septianwilliyanto@upi.edu}

Universitas Pendidikan Indonesia, Bandung, Indonesia

Abstract. The objectives of Physical Education include three aspects: cognitive, psychomotor, and affective. However, the Coronavirus 2019 outbreak is sweeping. The purpose of this study was to evaluate learning outcomes of Physical Education during the COVID-19 pandemic. This type of research is qualitative, the source of data for this study are Teachers, Students, and Parents. Data collection methods use observation, interviews, and documentation. Data analysis uses the triangulation method. Based on research, in the cognitive realm, primary school learning outcomes are 70%, junior high 75%, and high school 85%. The Psychomotor Domain, for Elementary School, is 45%, Middle School 60%, and High School 75%. And in the Affective domain, for Elementary School is 15%, Middle School 30%, and High School 65%. This study concludes that learning outcomes during a pandemic are not optimal. Suggestion: the government provides equipment lending services to students who do not have and provide internet network facilities.

Keywords: physical education learning, covid-19 pandemic, learning.

1 Introduction

The achievement is something that you did or got after planning and working to make it happen, and that therefore gives you a feeling of satisfaction or the act of working to make this happen [1]. Learning objectives are defined as behavioral goals that are to be achieved or that can be done by students according to competence [2]. Learning objectives are a target to be made by teaching activities [3]. From the above definition, it can be taken an understanding that the achievement of learning objectives is an outcome obtained from what has been targeted in the learning process.

According to bloom's taxonomy, learning objectives are grouped into three domains; cognitive domain, psychomotor domain, and affective domain. Cognitive learning related to knowledge, psychomotor learning about actions and motor skills, and affective learning related to attitudes, feelings, and emotions [4],[5],[6] and [7]. So in the context of learning, all three domains must be the target set by the teacher for their students, including in physical education learning.

Physical education is a subject taught from Primary to High School. Basically, Physical education is an educational process through physical activities. Physical education is an educational process through physical activities designed to improve

physical fitness, develop motor skills, knowledge, and healthy and active living behaviors, sportsmanship, and emotional intelligence [3], [8]. Physical education has a vital role in the promotion and acquisition of students' healthy behavior [9]. Physical education programs at schools provide a crucial environment for intervention in developing motoric competencies of school-age children and overall physical fitness, while also stimulating competency motivation to engage in physical activity[10]. However, currently, physical education learning is forced to be done online at home due to a coronavirus outbreak (COVID19).

Coronavirus (CoV) is a large family of viruses that can infect birds and mammals, including humans, this virus is zoonotic, meaning this is a disease that can be transmitted between animals and humans such as Rabies and Malaria[10]. According to WHO (World Health Organization), this virus causes diseases ranging from mild flu to more severe respiratory infections such as MERS-CoV and SARS-CoV. Currently, the coronavirus has spread almost all countries in the world, including in Indonesia. By 31 March 2020, there have been 1,528 confirmed COVID-19 cases in Indonesia and 136 deaths related to the disease[8]. COVID-19 also has a significant impact on education. One of the efforts made by the government is the issuance of a learning policy in a manner online in preventing the spread of COVID-19 through the MENDIKBUD Circular Letter No 36962 / MPK.A / HK / 2020 [11].

Online learning is a technology-based learning model through distance learning by using internet network facilities to be able to interact online[12]. In online education, the teacher and students are required to access the website using an updated device and internet support. Online learning tsunamis have occurred almost throughout the world during the COVID-19 pandemic[13]. Teachers and educators, as essential elements in teaching, are required to undertake unprecedented mass migrations from traditional face-to-face education to online education or distance education [14], [15].

From some of the above reviews, a conclusion can be drawn that the achievement of Physical Education learning objectives is grouped into three domains, namely; cognitive, psychomotor, and affective. The cognitive domain is related to thinking abilities, the psychomotor domain is similar to movement skills, and the affective domain is relevant to students' feelings. However, with the coronavirus outbreaks of physical education, learning must be done online. Some examples of journal articles that are reviewed in this study are:

The research of [16]. The purpose of this study was to identify obtaining information on the constraints of the online teaching and learning process at home as a result of the presence of a COVID-19 pandemic. The study used an exploratory case study method, and the research approach used a qualitative case study method that was used to obtain information on the constraints and consequences of the COVID-19 pandemic on teaching and learning activities in elementary schools. The results of this study are that there are several obstacles experienced by students, teachers, and parents in teaching and learning activities.

The research of [17]. The purpose of this study as a general review of learning during the COVID-19 pandemic. This research uses descriptive analysis study method. The results of this study are in the form of conclusions which are reviewed from several scientific articles. The outcome of this study is that online learning is the best solu-

tion. Still, it needs further research considering that the ability of the facilities provided by parents to students is different.

The article of [18]. The article aims to describe the extent of the implementation of the cognitive domain, affective domain, and psychomotor domains in grade III Primary School quantitatively. This study does during regular learning, or not in an emergency. This study uses a quantitative to describe cognitive, affective, and psychomotor learning outcomes into numbers.

The article of [8]. This article aims to explain the condition of the coronavirus outbreak in Indonesia. This research uses an analysis study method. The results of this study are the conclusions which are reviewed from several scientific articles. The results of the discussion in the form of an appeal to the community to remain silent at home to reduce spread COVID-19.

The article of [19]. This article is about the co-19 prevention movement and the things that must be done in prevention efforts. This research uses an analysis study method. The results of this study are in the form of conclusions which are reviewed from several scientific articles. The outcome is the movement to prevent rather than treat the good is still applied and not too late, considering that because the spread of the virus is swift and has claimed many lives.

2 Methodology

The type of study is quantitative with a descriptive approach/ survey. The purpose of the descriptive research method is to provide a systematic description or description related to the phenomenon being investigated. The object purpose of this study is a Primary School, Junior High School, and Senior High schools in COVID-19 affected areas. The source of the data in this study is teachers, students, and parents. The data collecting method is to use an observation technique, interview, and documentation. The data analysis used is the triangulation method by taking a conclusion. Data collection instruments in this study are :

2.1 Cognitive Variable Instrument

The cognitive domain can be measured in two ways, namely subjective and objective tests; individual tests are usually in the form of essays. Still, in practice, these tests cannot cover all the material to be tested[14]. The instrument in this study used an objective analysis.

Table 1. Cognitive Variable Instrument [18]

No.	Assessment Aspects	Respondent
1	Knowledge	Teacher, Students, & Parents
2	Comprehension	Teacher, Students, & Parents
3	Application	Teacher, Students, & Parents
4	Analysis	Teacher, Students, & Parents
5	Synthesis	Teacher, Students, & Parents
6	Evaluation	Teacher, Students, & Parents

2.2 Psychomotor Variable Instrument

Assessment of psychomotor learning outcomes in this study can be done using direct observation and evaluation of student behavior in the teaching-learning process, and the tools used in the measurement of the psychomotor domain are observation [14]. The psychomotor area is an area that deals with aspects of skills that involve the functioning of the nervous and muscular systems and mental functions [3].

Table 2. Psychomotor Variable Instrument [18]

No.	Assessment Aspects	Respondent
1	Basic Motion	Teacher, Students, & Parents
2	Physical Skills	Teacher, Students, & Parents
3	Skilled Motion	Teacher, Students, & Parents
4	Perceptual Skills	Teacher, Students, & Parents
5	Reflex	Teacher, Students, & Parents

2.3 Affective Variable Instrument

The instrument used in the measurement of affective domains is observation, because observations in taking data are not limited to people, but can also be used in the natural environment or the natural environment [14]. Classifying this affective domain into five levels, namely: (1) Receiving or paying attention (2) Responding, (3) Valuing, (4) Regulate or organize, and (5) Characterization with a value or group of profits [13].

Table 3. Affective Variable Instrument [5]

No.	Assessment Aspects	Respondent
1	Receiving	Teacher, Students, & Parents
2	Responding	Teacher, Students, & Parents
3	Valuing	Teacher, Students, & Parents
4	Organization	Teacher, Students, & Parents
5	Characterization	Teacher, Students, & Parents

3 Results

3.1 The Results

The policy of social distancing to minimize the spread of COVID-19 requires that all education units activate learning even though schools are closed. School closures are the most effective solution to reduce the spread of epidemics to students. During the pandemic COVID-19, online learning was the only way to continue the rest of the semester. In this study, interviews were conducted online by applying the COVID-19 preventive health protocol through the WhatsApp and zoom applications. The study was conducted in April and May 2020, in the area with the red zone COVID-19 status. The research sample selection uses a purposive sampling technique.

3.2 Physical Education Learning in Primary School

Information and multimedia technology are developing rapidly in all fields, including education. The most crucial goal of technology is to facilitate the work of everyone, especially for a teacher. However, in reality, there are many Physical Education teachers at the primary school level who have not utilized this facility. Physical education teachers complain that many students do not have smart phones so that physical education learning at the primary school level is mostly not implemented. In the study there were only 15% of teachers who carried out learning with the following results;

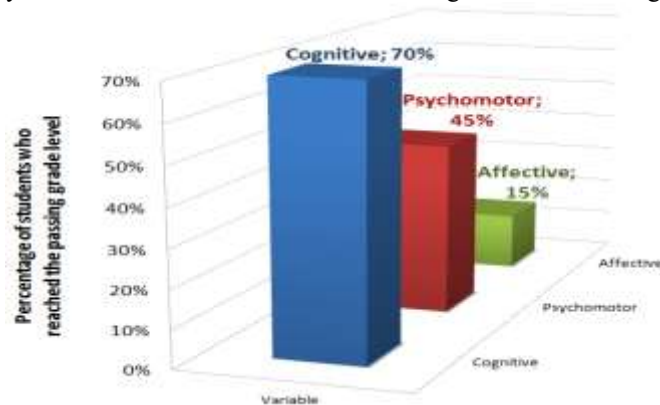

Fig. 1. Primary School Learning

Based on the results of the study, it was found that three out of nine Physical Education teachers in Elementary Schools only give assignments while studying at home by working on "Student Worksheets." But the teacher never asks for the work, because of the limitations of the communication media. And one teacher gives assignments in the form of videos and questions sent via WhatsApp. Another teacher does not give the task because the problem is the students do not have the facilities and infrastructure at home that can use, for example, Racket, ball, Long jump sandbox, and others

3.3 Physical Education Learning in Junior High Schools

The learning media is a supporting factor in Physical Education learning, meaning that the better the media used, the better the prospects for success in learning. The learning media is always developing, so teachers and students need to be able to use it. At the junior high school level, online-based physical education learning is not the best solution. The problem is, many students don't have smart phone devices, so students have to replace smart phones with their parents. Students' parents also found another problem; they felt that the assignment given by the teacher was quite heavy so that parents often did not understand when asked about learning material by their children. In junior high school learning research, the following results were obtained.

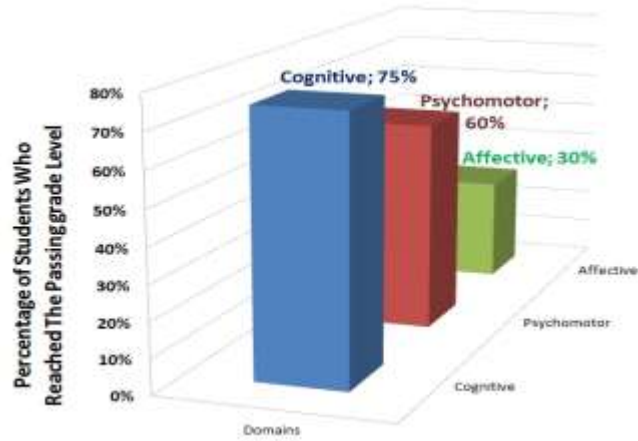

Fig. 2. Junior High School Learning

3.4 Physical Education Learning in Senior High Schools

In addition to facilities, infrastructure is also needed to support the Physical Education learning process. The required infrastructure includes the field, goal post, net, pole net, teacher's room, and others. Apart from devices, internet networks are essential things that must be present when learning online, because if the device is not connected to the internet network, then the machine will not function if used to communicate. The results of the study show the following data.

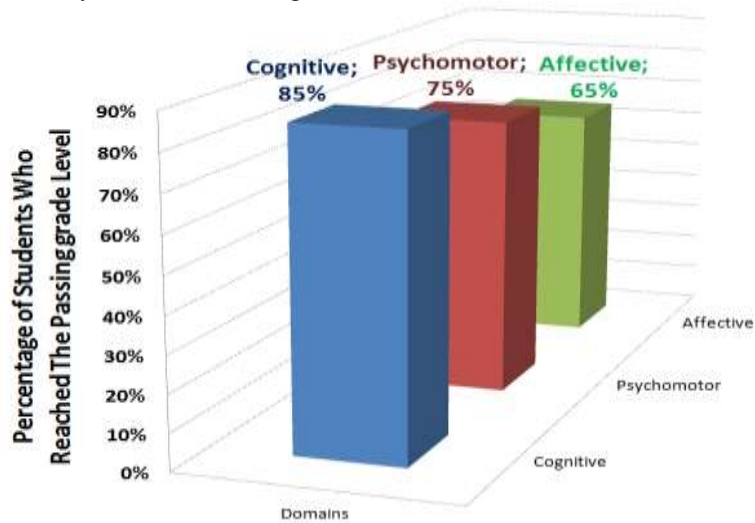

Fig. 3. Senior High School Learning

4 Discussion

The results showed that in the cognitive realm, the learning outcomes achieved up to 70% at the Primary School level, 75% at the Junior High School, and 85% at the Senior High School level. However, in the realm of psychomotor learning outcomes, only reached 45% for the Primary School level, 60% for the Junior High School level, and 75% for the Senior High School level. As for the Affective domain, the learning outcomes reach 15% for Primary School, 30% for Junior High School level, and 65% for Senior High School level.

The percentage of learning outcomes shows that physical education learning is not ready if it has to be done online, many things must be prepared to start from the availability of devices, internet channel support, and also human resources. According to [17], this needs to be evaluated and adapted to local conditions, given the ability of parents to provide different online learning facilities. From the development of information obtained, many teachers are entirely unaware of the latest communication technology at this time, so teachers do not provide learning material to their students. The statement is the same as the results of research from [16], the impact felt by teachers is that not all are proficient at using internet technology or social media as a learning tool, some senior teachers have not been fully able to use devices or facilities to support online learning activities and need assistance and training first.

From this information, it can be concluded that the development of technology in education is critical. A teacher and students must have the ability to be able to operate the latest devices that can support the educational process. Teachers and educators, as essential elements in teaching, are required to undertake unprecedented mass migrations from traditional face-to-face education to online education or distance education [14], [15]. This presents a challenge to all elements and levels of education to keep the class even though the school has closed [17].

5 Conclusion

The conclusion in this study is that the goal of online-based physical education implemented in schools affected by COVID-19 has not been reached to the fullest. This happens because several factors influence it. For example, the lack of facilities is the cause of decreased enthusiasm for students themselves. Many students do not collect assignments given by the teacher. They feel that while at home, there are no teachers or supervisors. It happened because their parents were also busy looking for other income to shop for daily needs. Various problems that occur cause a decrease in student enthusiasm, even resulting in reduced student presence in the learning process.

Suggestions from researchers: The government and the school should find a solution from the evaluation of learning happening in our country today. In this case, efforts that can be done by the government are by providing loaning services for students who do not have a device, and providing services in the form of internet channel assistance so that communication in learning will continue well.

Acknowledgements

We would like to thank Faculty of Sport and Health Education, Universitas Pendidikan Indonesia, Indonesia for the funding.

References

- [1] <https://dictionary.cambridge.org/dictionary/english/achievement>. [Accessed: 23-Jun-2020].
- [2] <http://biosaefful.blogspot.com/2013/05/definisi-manfaat-dan-tujuan-pembelajaran.html>. [Accessed: 24-Jun-2020].
- [3] Sulaiman, *Strategi Pembelajaran Pendidikan Jasmani, Olahraga, dan Kesehatan Dengan Pendekatan Sistem*, Pertama. Semarang: CV. Swadaya Manunggal, 2016.
- [4] A. Noorhidawati A, S. G. Ghalebandi, and R. S. Hajar, "How Do Young Children Engage with Mobile Apps ? Cognitive , Psychomotor , and Affective Perspective Computers & Education How do young children engage with mobile apps ? Cognitive , psychomotor , and affective perspective," *Comput. Educ.*, vol. 87, no. August, pp. 385–395, 2015.
- [5] http://www.unco.edu/cetl/sir/stating_outcome/documents/Krathwohl.pdf. Last accessed. [Accessed: 24-Feb-2014].
- [6] <http://www.rockymountainalchemy.com/whitePapers/rma-wp-learning-taxonomies.pdf>. [Accessed: 24-Feb-2014].
- [7] <http://www.edpsycinteractive.org/topics/cognition/bloom.pdf>. Last accessed.
- [8] S. Setiati, and M.K. Azwar, "COVID-19 and Indonesia," no. April, 2020.
- [9] A. Granero-Gallegos et al., *Importance of Physical Education: motivation and motivational Climate*, Vol. 132,. Elsevier, Science Direct : Procedia – Social and Behavioral Sciences.
- [10] X. Gu, Y. Chen, A.W. Jacson, and T. Zhang, "Impact of a pedometerbased goal-setting intervention on children's motivation, motor competence, and physical activity in physical education," *Phys. Educ. Sport Pedagog.*, 2017.
- [11] <https://www.kemkes.go.id/article/view/20031900002/Dashboard-Data-Kasus-COVID-19-di-Indonesia.html>.
- [12] N. Putranti, "Cara Membuat Media Pembelajaran Online Menggunakan Edmodo," *J. Pendidik. Inform. dan Sains*, vol. 2(2), 139-, 2016.
- [13] Goldschmidt, K, & Msn, P.D, "The COVID-19 pandemic : Technology use to support the wellbeing of children," *J. Pediatr. Nurs.*, vol. xxxx, 3–5, 2020.
- [14] Bao, W, "COVID-19 and online teaching in higher education : A case study of Peking University," no. March, pp. 113–115, 2020.
- [15] Basilaia, G, and Kvavadze, D, "Transition to Online Education in Schools during a SARS-CoV-2 Coronavirus (COVID-19) Pandemic in Georgia," *Pedagog. Res.*, vol. 5(4), 2020.
- [16] A, Purwanto, R, Pramono, M, Asbari, P.B, Santoso, L.M, Wijayanti, C.C, Hyun, and R.S, Putri, "Studi Eksploratif Dampak Pandemi COVID-19 Terhadap Proses Pembelajaran Online di Sekolah Dasar," *J. Educ. Psychol. Couns.*, vol. 2 No. 1, pp. 1–12, 2020.
- [17] L. D. Herliandry and M. E. Suban, "Jurnal Teknologi Pendidikan Pembelajaran Pada Masa Pandemi Covid-19," vol. 22, no. 1, pp. 65–70, 2020.
- [18] I. Nurbudiyani, "Pelaksanaan Pengukuran Ranah Kognitif, Afektif, Dan Psikomotor Pada Mata Pelajaran Ips Kelas Iii Sd Muhammadiyah Palangkaraya," *Anterior J.*, vol. 13 No. 1, no. Desember 2013, pp. 88–93, 2013.
- [19] W. Zendrato, "Gerakan Mencegah Daripada Mengobati COVID-19," *J. Educ. Dev. Inst. Pendidik. Tapanuli Selatan*, vol. 8 No.2, no. Edisi Mei, 2020.

Physical Exercises cause Muscle Damage and Potential Treatments to Increase Range of Motion

Setya Rahayu¹, Mohammad Arif Ali², Natsuangkorn Kongchulagul³,
Ebenezer Silaban⁴, Didit Prakosa Adi Nugroho⁵, Muchamad Sadhali⁶,
Sugiarto⁷, Gustiana Mega Anggita⁸
{setyarahayu@mail.unnes.ac.id¹, hiarifalikhhan@mail.unnes.ac.id²,
natsuangkorn.ko@ised.tu.ac.th³}

Universitas Negeri Semarang, Semarang, Indonesia¹²
Kasetsart University, Bangkok, Thailand³

Abstract. Flexibility is one key of physical fitness components, it is quite important to support daily activity and sport performances. This study aims to identify what type of physical exercises induce muscle damage, to evaluate changes in flexibility (ROM), and to identify potential flexibility training. Original studies which no longer than ten years were considered in this study (secondary data), and other significant references also acceptable to support the storylines. The first step was codifying, followed by analysis and synthesis, and last step was conclusion drawing. It must be done sequentially to reveal the reasonable answers. Eccentric muscle contraction, excessive volume, and prolonged duration are factors of training which lead muscle injuries. ROM is decreased due to muscle damage, it last longer in untrained men. Stretching, foam rolling, sport massage, Proprioceptive Neuromuscular Facilitation (PNF) are potential flexibility trainings might be able to improve ROM and accelerate healing process in muscle damaged.

Keywords: eccentric exercise; range of motion (ROM); muscle health.

1 Introduction

Physical exercise is a systematic activity in a certain time with goals setting. Training program in elite sports aims to improve athletes' skills, while in trained people besides exercise as part of their lifestyle, usually it aims to improve overall health status. A training without program is most likely cause injury, while in athletes or trained population injury usually due to excessive or prolonged exercise [1] [2]. The response of our body when getting excessive exercise will stimulate and experience damage to muscle tissue [3]. The occurrence of an inflammatory response is a continuous response to tissue injury by immune system due to injury [4]. Excessive training must be done with a well-designed program. Excessive weight training is provided

with the aim that physiological functions can adjust to the demands of the functions needed at a high level [5].

Sports injuries are damage that occurs in organs of the body that carry out sport activities. Muscle will suffer injury because of the breakdown of some muscle fibers due to exercise, after a few hours later it will feel muscle aches and can last for several days [6]. Delayed Onset Muscle Soreness (DOMS) is a form of injury, delayed muscle pain that often occurs after training caused by muscle tissue damaged due to performing continuous or too heavy exercise programs. [7]. DOMS is a condition in which pain and discomfort that occurs in nerve muscles, and the metabolic system about 24 hours after exercise, reaches a peak after 24 hours to 72 hours and the effect will gradually disappear after 5-7 days later [8].

Muscle injuries decrease body functions including pain, increased muscle circumference, decreased Range of Motion (ROM), decreased muscle strength, and increased inflammatory response [9][10][11]. ROM can be affected by daily habits such as squatting toilets, sitting cross-legged, squatting, and kneeling. These activities or habits can affect ROM in the hips, knees and ankle joints [12]. Apart from physical activities, decreased ROM occur when the body does not do enough physical activity which causes a decrease in musculoskeletal also called muscle atrophy [13].

According to the elucidation above, the purposes of this study are: 1) to identify what type of physical exercises induce muscle damage, 2) to evaluate changes in flexibility (ROM) during muscle damage, and 3) to identify potential flexibility training.

2 Materials and Methods

Materials, data in this traditional literature review are secondary. data stations such as Google Scholar, PubMed, ResearchGate, Reports, Blogspots, News Paper, et cetera were being accessed to collect related materials. Original studies which no longer than ten years were considered being used in this survey paper, therefore data are secondary. However, usage of other significant references also acceptable to support the storylines. Twenty-five papers cited in this study, twenty papers (80%) were published between years 2010 to 2020; three papers (12%) year 2008, 2004 and 2001; last two papers (8%) year 1992 and 1987.

Methods, the first step was codifying (collecting and sorting all related studies from sources). The second was Analysis and Synthesis, in this step data extraction initially performed then followed by detailed examination on how data from chosen materials could be constructed into data interpretation. The last step was the end of literature study process by conclusion drawing. All the steps must be done sequentially in order to reveal the reasonable answers.

3 Results and Discussion

3.1 Eccentric Exercise

Studies show that eccentric physical exercise is the most accurate causing muscle damage. Eccentric physical exercise particularly in resistance exercise is a training

which skeletal muscle performing extending contraction (muscle fibers are extended) to produce strength [14]. The modes of eccentric exercise such as uphill and downhill running, long distance running (marathon), and weight lifting [15]. Eccentric muscle contractions with high strength will result in pain and damage to the muscles in a temporary time, evidence of damage is pain due to damaged muscle fibers [16].

Muscle damage as a response of eccentric training contributes to DOMS phenomenon. A shift in optimum length for tension in the direction of longer muscle lengths caused sarcomeres being rapidly, uncontrollably, and repeated overstretched beyond myofilament overlap and tension in passive structures. Once the disrupted region getting larger, it leads to membrane damages especially to the sarcoplasmic reticulum. At this stage, excessive Ca^{2+} release triggering of a local injury contracture. Therefore, muscle passive tension would raise. This damage leads to a local inflammatory response associated with tissue oedema and soreness, (Figure 1).

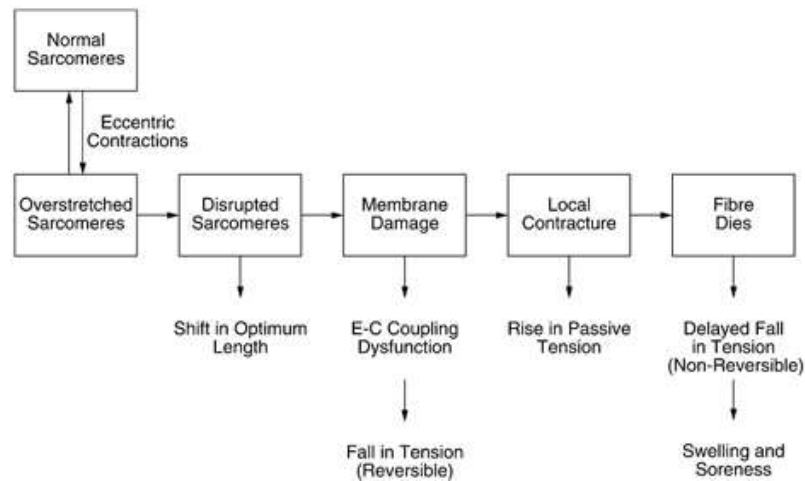

Fig. 1. Eccentric exercise leading to muscle damage. Figure is adopted from Proske U, Morgan DL [17]

Apart from causing muscle injury and tissue damage while doing extrinsic exercises, there are advantages to doing this exercise. Especially weight lifting is very effective for increasing hypertrophy, experiencing more significant developments in muscle size and strength. The body can use much heavier weights (1.75 times heavier than normal weights) in eccentric exercises.

3.2 ROM responses on muscle damage

Range of Motion is a movement that under normal circumstances can be carried out by the joint in question. ROM is the standard term for expressing the limit/magnitude of normal good joint motion. ROM is also used as a basis for establishing abnormal joint movement boundaries. In a state of muscle damage, muscles that experience stiffness will experience obstacles when performing scope of joint motion.

The flexibility of the body is affected by the state of the muscles that are experiencing pain due to eccentric exercise. When the body experiences muscle damage it will affect the scope of joint motion. Muscle damage after physical exercise will induce pain, decreased range of motion (ROM), increased muscle circumference that can damage, and decreased muscle strength [15][10][11].

A comparison study on ROM response between trained men versus untrained men after performing 10 sets of 6 maximal voluntary eccentric actions of the elbow flexors of one arm against the lever arm of an isokinetic dynamometer moving at a constant velocity of $90^{\circ} \cdot s^{-1}$ shows that eccentric physical exercise directly affecting in both trained and untrained men. However, trained men obviously having light response and recover earlier at the first day post eccentric exercise compared to untrained men, while untrained men were not even return to their baseline until five days post eccentric exercise, (Figure 2).

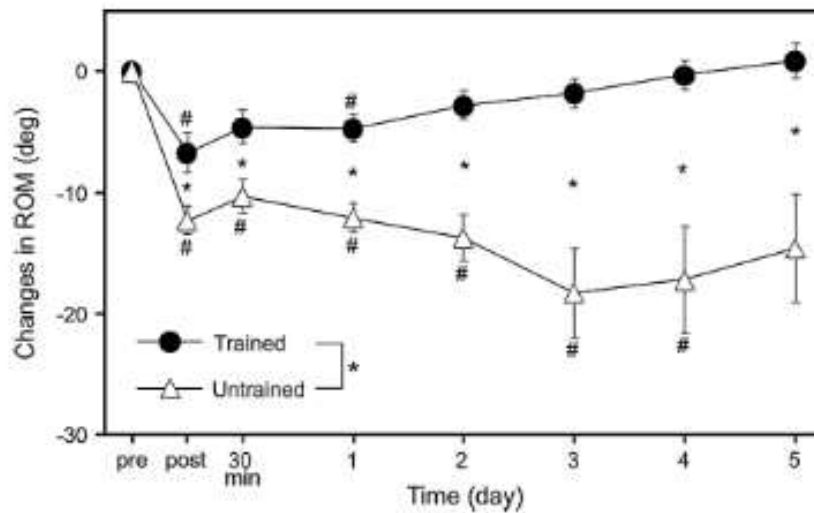

Fig. 2. Changes in ROM from baseline (pre: 0) immediately (post) and 30 minutes after exercise, and 1–5 days after exercise for the trained and untrained groups. *Significantly different between groups (interaction: P , 0.05, each time point: P , 0.007), #Significantly different from pre-exercise value. Figure is adopted from Newton MJ, Morgan GT, Sacco P, Chapman DW, Nosaka K., 2008. [18]

3.3 Flexibility exercises as treatment on muscle damage

Flexibility is an important part in various sports [19]. Flexibility is the ability to make movements in the joint motion by being affected by the elasticity of muscles, tendons, and ligaments. Physical activity, obesity, age, gender, bone structure, muscle, joint size, and connective tissue around the joints are determinants of flexibility [20]. The design and various exercises to increase body flexibility vary according to the goals and areas to be improved, whether it is upper extremity or lower extremity.

Stretching has an important role in the treatment of damaged soft tissue. When a muscle experiences strain due to exercise, stretching usually being used as a method of recovering the muscular system including tendon or after acute trauma. It is used to treat over-strained muscles and for relaxation [21]. Especially static stretching is recommended as a way to prepare muscle groups at the beginning of endurance training, because it is believed that this type of stretching can prevent DOMS.

Foam roller is a recovery tool which is used after physical exercise to correct muscle imbalance, reduce muscle pain, reduce joint stress, neuromuscular efficiency, and increase ROM. Foam rolling usually performed for recovery after exercise. Foam rolling can reduce muscle pain. Foam rolling is also believed able to improve muscle imbalance, reduce muscle pain, increase ROM and coordination, improve neuromuscular efficiency, and help reduce stress on joint motion [8][22]. When it is used as a tool to warm up before physical exercise, it can increase flexibility [19].

A study conducted by Macdonald Graham Z. showed that self-myofascial release using foam roller has significant effect on improving ROM. It is significantly increased 12.7% at 2 minutes and 10.3% at 10 minutes respectively post foam rolling compared to control group who did not use foam roller, (Figure 3).

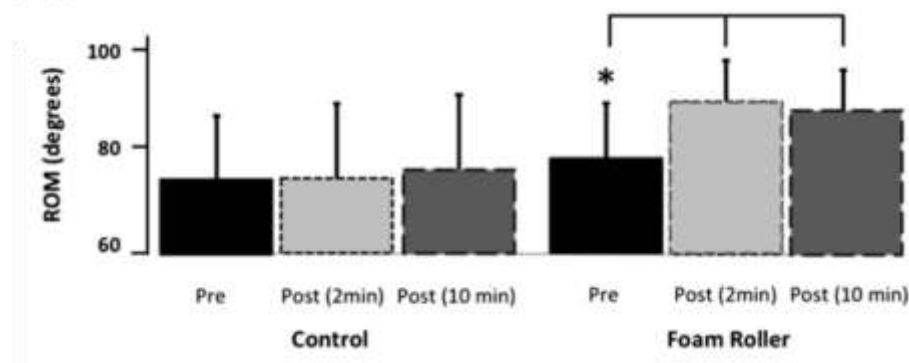

Fig. 3. Knee joint ROM did not change in the control condition but significantly increased after foam rolling. * Represents a statistical significance at $P < 0.001$. All data are presented as mean \pm SD. Figure is adopted from Macdonald Graham Z., 2013. [22].

Sport massage treatment after a long period of competition or working with short break, it can be an alternative to relieve the feeling of a raft, including when the body experiences a muscle damage grade I. Sport massage can help in increasing flexibility. Additionally, the manipulation of sport massage with its application can reduce the tension of non-active muscle antagonists [23].

Proprioceptive Neuromuscular Facilitation (PNF) is another form of flexibility exercise. PNF stretching training technique is a therapy by providing stimulus to proprioceptors as a easier way to increase the need for mechanisms of neuromuscular system [24]. This method seeks to provide stimuli according to expected reactions, which in turn will be achieved ability or movement that is coordinated. PNF will strengthened and intensified specific stimuli through joint receptors (proprioceptive). Neuromuscular, also increases the response of the neuromuscular system [25].

4 Conclusion

Exercises which involved eccentric muscle contraction, excessive volume, and prolonged duration are types of training with high risk of injuries. Range of Motion is decreased due to muscle damage, and it last longer in untrained than in trained men. Stretching, foam rolling, sports massage, and Proprioceptive Neuromuscular Facilitation (PNF) are considered as potential flexibility trainings which might be could improve ROM and accelerate the healing process in muscle damage.

Acknowledgments

This study is part of an investigation about effects of high density foam roller on blood lactate and range of motion as indicators of delayed-onset muscle soreness (DOMS) post long distance running in trained young males. This study was granted by Research and Community Services Institute of UNNES/*Lembaga Penelitian dan Pengabdian kepada Masyarakat*, Universitas Negeri Semarang (*DIPA UNNES Tahun Anggaran 2020. Nomor Surat Perjanjian Penugasan: 234.23.4/UN37/PPK.3.1/2020*).

References

- [1] A. Setiawan, Factors for Sports Injuries. "Faktor Timbulnya Cedera Olahraga," *J. Media Ilmu Keolahragaan Indones.*, vol. 1, no. 1, 2011.
- [2] F. P. Sastra, Differences in the Effect of Kinesio Taping Hamstring on Pain Reduction during Delay Onset Muscle Soreness (Doms). "Perbedaan Pengaruh Pemberian Kinesio Taping Hamstring Terhadap Penurunan Nyeri Saat Kejadian Delay Onset Muscle Soreness (Doms)," Universitas Muhammadiyah Surakarta, 2018.
- [3] D. Z. Sidik, Principles Of Training Principles In Sports Achievements. "Prinsip Prinsip Latihan Dalam Olahraga Prestasi," pp. 1–8, 2010.
- [4] S. Sari, vercome Doms After Sports."Mengatasi Doms Setelah Olahraga," *Motion*, vol. 7, no. 1, pp. 97–107, 2016.S
- [5] Y. O. Seneva, The Effect Of Load Training Method Of Circuit Strength Muscle Strength In Fc Uny Players In Facing Around Around Years 2018. "Pengaruh Latihan Beban Metode Circuit Kekuatan Otot Tungkai Pada Pemain Fc Uny Dalam Menghadapi Liga Nusantara Tahun 2018," Universitas Negeri Yogyakarta, 2018.
- [6] A. S. Graha, Benefits Rest In Post Of Injuries Due To Sports. "Manfaat Istirahat Pada Pasca Cedera Akibat Berolahraga," *MEDIKORA*, vol. 18, no. 1, pp. 49–55, Dec. 2019.
- [7] H. S. Lesmana, rofile Of Delayed Onset Muscle Soreness (Doms) In Fik Unp Students After Physical Training. "Profil DELAYED ONSET MUSCLE SORENESS (DOMS) Pada Mahasiswa FIK UNP Setelah Latihan Fisik," *Hal. Olahraga Nusant.*, vol. 2, pp. 1–96, 2019.
- [8] G. E. P. Pearcey, D. J. Bradbury-Squires, J. E. Kawamoto, E. J. Drinkwater, D. G. Behm, and D. C. Button, "Foam rolling for delayed-onset muscle soreness and recovery of dynamic performance measures," *J. Athl. Train.*, vol. 50, no. 1, pp. 5–13, 2015.
- [9] R. G. Eston, G. Gleim, M. P. Mchugh, D. A. J. Connolly, R. G. Eston, and G. W. Gleim, "Exercise-Induced Muscle Damage and Potential Mechanisms for the Repeated Bout Effect Exercise-Induced Muscle Damage and Potential Mechanisms for the Repeated Bout Effect," vol. 27, no. July, pp. 157–170, 2014.

- [10] E. C. D. Burnley, A. N. Olson, R. L. Sharp, S. M. Baier, and D. L. Alekel, "Impact of Protein Supplements on Muscle Recovery After Exercise-induced Muscle Soreness," *J. Exerc. Sci. Fit.*, vol. 8, no. 2, pp. 89–96, 2010.
- [11] C. R. Denegar and D. H. Perrin, "Effect of transcutaneous electrical nerve stimulation, cold, and a combination treatment on pain, decreased range of motion, and strength loss associated with delayed onset muscle soreness.," *J. Athl. Train.*, vol. 27, no. 3, pp. 200–206, 1992.
- [12] H. Hallaçeli *et al.*, "Normal hip, knee and ankle range of motion in the Turkish population," *Acta Orthop. Traumatol. Turc.*, vol. 48, no. 1, pp. 37–42, 2014.
- [13] U. Sarah and S. Bambang, Influence of Range of Motion (ROM) Exercise on Knee Joint Flexibility in the Elderly at Wardoyo Weda Wardoyo Ungaran. "Pengaruh Latihan Range of Motion (Rom) Terhadap Fleksibilitas Sendi Lutut Pada Lansia Di Panti Wreda Wening Wardoyo Ungaran," *Nurse Media J. Nurs.*, vol. 1, no. 2, pp. 72–78, 2010.
- [14] Athanasios Z. Jamurtas. Ioannis G. Fatouros, "Eccentric Exercise, Muscle Damage and Oxidative Stress," *An Int. Perspect. Top. Sport. Med. Sport. Inj.*, 2012.
- [15] R. Eston, C. Byrne, and C. Twist, "Muscle function after exercise-induced muscle damage: Considerations for athletic performance in children and adults," *J. Exerc. Sci. Fit.*, vol. 1, no. 2, pp. 85–86, 2004.
- [16] D. J. Newham, D. A. Jones, and P. M. Clarkson, "Repeated high-force eccentric exercise: Effects on muscle pain and damage," *J. Appl. Physiol.*, vol. 63, no. 4, pp. 1381–1386, 1987.
- [17] U. Proske and D. L. Morgan, "Muscle damage from eccentric exercise: mechanism, mechanical signs, adaptation and clinical applications," *J. Physiol.*, vol. 537, no. 2, pp. 333–345, Dec. 2001.
- [18] M. J. Newton, G. T. Morgan, P. Sacco, D. W. Chapman, and K. Nosaka, "Comparison of responses to strenuous eccentric exercise of the elbow flexors between resistance-trained and untrained men," *J. Strength Cond. Res.*, vol. 22, no. 2, pp. 597–607, 2008.
- [19] C. A. Peacock, D. D. Krein, T. A. Silver, G. J. Sanders, and K.-P. A. VON Carlowitz, "An Acute Bout of Self-Myofascial Release in the Form of Foam Rolling Improves Performance Testing.," *Int. J. Exerc. Sci.*, vol. 7, no. 3, pp. 202–211, 2014.
- [20] F. Az-zahra, Nastiti dan Ichsani, Contract Relax Stretching Is More Effectively Improve The Flexibility Of Muscle Hamstring Compared To Passive Stretching In The Taxwondo Club Underdog Athlete. "Efektivitas Antara Latihan Kontraksi Eksentrik Hydroterapy Dengan Latihan Ballistic Stretching," *J. Fisioter.*, vol. 16, no. 1, 2016.
- [21] A. Wiguna, D. Silakarma, and R. Sundari, "Contract Relax Stretching Lebih Efektif Meningkatkan Fleksibilitas Otot Hamstring Dibandingkan Dengan Passive Stretching Pada Atlet Underdog Taekwondo Club," vol. 000, pp. 1–13, 2014.
- [22] graham z. Macdonald, "An Acute Bout Of Self-Myofascial Release Increases Range Of Motion Without A Subsequent Decrease In Muscle Activation Or Force," *J. Strength Cond. Res.*, pp. 812–821, 2013.
- [23] A. Mostafaloo, "The effect of one session massage in the lower limb muscle on flexibility, power and agility tests performance in soccer players," *Pars Jahrom Univ. Med. Sci.*, vol. 10, no. 2, pp. 17–24, 2012.
- [24] S. Alfarisi, Influence of PNF (Proprioceptive Neuromuscular Facilitation) and Thai Massage Exercises on the Level of Flexibility of the Uky Karate Inkai Athletes Uny. "Pengaruh Latihan Pnf (Proprioceptive Neuromuscular Facilitation) Dan Thai Massage Terhadap Tingkat Fleksibilitas Togok Atlet Ukm Karate Inkai Uny," vol. 2, pp. 6–11, 2018.
- [25] A. Alim, Flexibility Training with the PNF Method. "Latihan Fleksibilitas dengan Metode PNF," *Artik. e-staff FIK UNY*, pp. 1–9, 2012.

The Potential of Red Beetroot Powder as an Athlete Supplementation According to Its Organoleptic Properties

Setya Rahayu¹, Natalia Desy Putriningtyas², Tandiyoh Rahayu³, Mahalul Azam⁴,
Eka Yuli Astuti⁵

{setyarahayu@mail.unnes.ac.id¹, nataliadesy@mail.unnes.ac.id²,
tandiyorahayu@mail.unnes.ac.id³}

Universitas Negeri Semarang, Semarang, Indonesia^{1,2,3,4,5}

Abstract. Athletes consume dietary supplements to enhance their training capacity and performance. Beetroot (*Beta vulgaris*) is a vegetable that is widely used as a dietary supplement for athletes. Beetroot contains bioactive components such as betalains, vitamin C, polyphenols, flavonoids, and saponins. Its powder form is preferable because it is easier to consume and has a longer shelf life. This study aims to compare organoleptic tests of beetroot powder, which include tastes, and color. Corn sugar is added to the beetroot powder with different composition of 5%, 10%, and 15%. Organoleptic tests were measured by the hedonic scale method. The results from the Kruskal Wallis test showed that there was a significant difference between groups ($p < 0.05$). Beetroot powder with 10% of corn sugar receives the highest acceptance among panelists and has a promising potential as a dietary supplement for the athletes.

Keywords: beetroot, organoleptic test, athlete

1 Introduction

Beta vulgaris l, commonly known as beetroot, is a vegetable from family Chenopodiaceae [1]. Beetroot is often considered as a tuber and easy to grow in almost all over the world. It can be consumed raw or roasted and often served as a soup or a part of a salad. Beetroot is a great source of betalains, polyphenols, vitamin C, carotene, flavonoid saponin, and NO^{3-} . Vulgaxanthine I, vulgaxanthine II, indicaxanthine, betanin, prebetanin, isobetanin, and neobetanin are betalains components that also found in beetroot [2]. Betalains are pigment components of beetroot. Additionally, beetroot is also rich in phenols, including phenolic acids, flavonoids, organic acids, and inorganic acids [3]. Studies found that beetroot is a potential therapeutic agent. Beetroot supplements are reported to have potential in lowering blood pressure, preventing inflammation, and maintaining the endothelial function and hemodynamic

[4]. Moreover, flavonoids in beetroot act as antioxidants whose activity is as high as 79.73 ppm [5].

Antioxidant activity is related to oxidative stress. High intensity and continuous exercise can trigger the stress as well as DNA degeneration. Reactive oxygen species (ROS), which are the primary source of oxidative stress, are produced by mitochondria during exercise. Continuous and high-intensity exercises may cause an imbalance of ROS and antioxidants. 2-5% of the oxygen used in mitochondria comes from free radicals. Exercise increases oxidative phosphorylation response that triggers free radical propagation. Catecholamines released during exercise may also trigger the production of free radicals. Other free radical compounds increased during exercises are the compounds involved in prostanoid metabolism, xanthine oxidase, NAD(P)H oxidase, and other secondary sources released as radical macrophages during tissue repair [6]. Aerobic and anaerobic exercises may increase the free radical formation and cause acute oxidative stress. The homeostatic imbalance caused by exercises depends on various risk factors such as type of exercise, intensity, duration, level of exercise, gender, age, and dietary intake [7].

Athletes are the main target of supplement consumption. Antioxidant supplementation given to athletes prevents excessive oxidative stress during exercise. If free radical exceeds antioxidant capacity, it will attack the cellular compounds. Beetroot juice supplementation is shown not to improve water polo athletes' performance, although it has ergogenic potential during dynamic apnea [8]. Beetroot powder supplementation on athletes is able to optimize response performance during submaximal run training or maximal treadmill [9]. Beetroot powder is preferred because it is easy to consume and has the feasibility of product diversification or improvement. This study aims to compare the organoleptic properties (taste, and color) of beetroot powder that has been formulated with various percentages of corn sugar. Sugar is one of the food agents used as natural preservatives and stabilizers.

2 Methods

This study was conducted from February to March 2020. Beetroots were obtained from organic farmers in Pakis and Ngablak Village, Magelang district, Central Java. Chosen beetroots have soft skin and long shelf life. Beetroots selection was started from removing soil, worm, or soiled part of beetroots. It was cleaned under flowing water, brushed, and sundried for a day. The blanching process using hot water is avoided to not lose the betalain content due to water dissolution. Beetroots were chopped into 1 mm size using bowl chopper before being crushed with a juice extractor and spray dried.

Corn sugar was then added into beetroot juice with 5%, 10%, and 15% composition each (w/w). A juice extractor would separate the juice from the pulp and the skin using a cold-pressed method and hydraulic utilization of 120kg/h capacity. This technology mainly operates in two steps: the pulp's production from raw materials, then

hydraulically pressed with a vertical pressure that extracts the juice from the pulp. The final product of cold-pressed juicers is more homogenous than centrifugal juicers (common juicers).

This experiment produced three varieties of beetroot powder with corn sugar addition of 5%, 10% and 15%. The solution of beetroot juice and corn sugar was evaporated by an evaporator. Evaporator transforms beetroot solution by heating the solution, and the formed vapor was condensed when it passed the condenser. During this process, the beetroot solution turned into a solid form with volatile compounds and low water content. The last process to produce the beetroot powder is crystallization. Crystallization process was chosen to produce a higher purity of beetroot content in the powder.

Organoleptic properties were observed by 25 not trained panelists consisted of 15 females and 10 males at Nutrition Laboratory, Universitas Negeri Semarang. All categories in organoleptic tests were evaluated using the hedonic test scale of 1-4 (Extremely dislike to Extremely like). The tested categories were tastes, and color. Data obtained from the organoleptic test were then analyzed by the Kruskal Wallis with a p-value of 0.05 to determine significance. Ethical clearance has been obtained before the study is carried out with the number 067/KEPK/EC/2020.

3 Results and Discussion

Table 1. Frequency Distribution of Beetroot Powder Organoleptic Test

Groups	Frequency Distribution of Organoleptic Properties		
	Taste	Color	Overall
A			
- Dislike extremely	1 (4%)	3 (12%)	4 (16%)
- Dislike	14 (56%)	10 (40%)	10 (40%)
- Like	9 (36%)	10 (40%)	10 (40%)
- Like extremely	1 (4%)	2 (8%)	1 (4%)
B			
- Dislike extremely	0 (0%)	0 (0%)	0 (0%)
- Dislike	2 (8%)	4 (16%)	2 (8%)
- Like	13 (52%)	13 (52%)	16 (64%)
- Like extremely	10 (40%)	8 (32%)	7 (28%)
C			
- Dislike extremely	0 (0%)	2 (8%)	0 (0%)
- Dislike	11 (44%)	12 (48%)	9 (36%)
- Like	8 (32%)	6 (24%)	7 (28%)
- Like extremely	6 (24%)	5 (20%)	9 (36%)

A: beetroot powder, corn sugar 5%; B: beetroot powder, corn sugar 10%; C: beetroot powder, corn sugar 15%

Table 1 shows that most of the panelists preferred beetroot powder with 10% corn sugar. Beetroot is a source of antioxidant with phenolic amides, flavonoids, betalains, and ferulic acid conjugates content [10]. Betalains are a bioactive pigment often found in vegetables. The family member of betalains can be categorized as betacya-

nin—a red-violet pigment or betaxanthine—a yellow-orange pigment [4]. Betalains are water-soluble pigments that do not bind to surfaces but stain the sample. During heating, betalains will have a change color from red to yellow due to thermochemical reactions. Increased temperature allows the red pigment to change into yellow by the browning reaction. The yellow pigment is more stable in high temperatures compared to the red pigment [11]. During the spray drying process, moisture in beetroot juice is eliminated through atomization by heat. The corn sugar causes the water molecules to bind to dry beetroot powder and creates a monolayer bond with a soft texture and low water content.

Beetroot supplementation is considered a strategic plan to increase endogenous antioxidant capacity and helps to protect cells from oxidative damage. The biological environment of cells refers to the redox balance—an equilibrium between reducing (antioxidants) and oxidizing (pro-oxidants) [4], [12]. Exposure to external risk factors, namely ultraviolet radiation, xenobiotics, or endogenous synthesis derived from reactive oxygen and nitrogen species (RONS) such as inflammation, can reduce the antioxidants defense capacity and cause cellular impairment.

Beetroot consists of 87.57% water; 9.56% carbohydrate (29.3% fiber and 70.7% sugar); 1.61% protein, 0.17% fat, and several minerals namely potassium, choline, vitamin C, and niacin [13]. The powder form is the preferred final product of this experiment. In powder form, beetroot can be stored for a longer time, reduces the risk of biological damage and preserves pigments [1]. It is also easy to consume and increases the solubility level [14].

Table 2. Table 3. Mean Difference

Groups	Mean Rank		
	Taste	Color	Overall
A	32.60	39.44	30.46
B	47.86	44.68	44.58
C	33.54	29.88	38.96
<i>p</i>	0.012*	0.035*	0.048*

A: beetroot powder, corn sugar 5%; B: beetroot powder, corn sugar 10%; C: beetroot powder, corn sugar 15%, *p** significant, *Kruskal wallis test*

Color is the main part of visual appearance, as it affects consumers' perception of food and expectation on the taste and smell of the product [15]. Table 2 displays significant differences of organoleptic test results between beetroot powder with 5%, 10%, and 15% of corn sugar in taste and overall appearance. Corn sugar is widely known as D-glucose or dextrose, with a chemical name of α -D-glucopyranose. Corn sugar comes from anhydrous or monohydrate compound that undergoes a complete hydrolysis process in acidic or enzymatic conditions. After the hydrolysis process, the refinement and the crystallization process of hydrolysate follow. Initially, corn sugar was likened to high fructose corn syrup (HFCS). HFCS consists of glucose and fructose with a ratio of 50:50 and is obtained from corn starch. Meanwhile, corn sugar is more similar to dextrose and biochemically, similar to glucose. HFCS is more similar

to fructose and can be found in fruits. Corn sugar also acts as a binder in the beetroot powder [11].

Dextrose and glucose are carbohydrates that are easily digested. Glucose is a fast-digested carbohydrate thus is easily absorbed into blood circulation. Glucose will be oxidized through skeletal muscles during exercise. Fructose and galactose undergo different digestion processes compared to glucose. Fructose and galactose take longer to digest as they are related to hepatic metabolism. Meanwhile, fructose will be oxidized as fast as 0.38 g/min if digested alone or combined with glucose. Meanwhile, the oxidation rate of glucose is 3.0 g/min. The glucose oxidation is also facilitated by sodium-dependent glucose cotransporter (SGLT1), which also contributes to glucose absorption through active transport past membrane brush border on small intestines. Beetroot powder with corn sugar is expected to increase the SGLT1 transport.

Further studies are recommended to evaluate beetroot powder's physical appearance, including viscosity and osmolality, and to carry out laboratory tests regarding its antioxidant contents.

4 Conclusion

Beetroot powder with 10% corn sugar potentially receives the highest acceptance among the panelists. Beetroot powder is a potential functional food for athletes due to its betalain content.

Acknowledgments

We would like to thank Faculty of Sport Science, Universitas Negeri Semarang, Indonesia.

References

- [1] A. S. Varner, "Modeling and Optimization of the Dehydration of Beets for Use As a Value-Added Food Ingredient," p. 88, 2014.
- [2] M. V. Garnacho-Castaño *et al.*, "Effects of a single dose of beetroot juice on cycling time trial performance at ventilatory thresholds intensity in male triathletes," *J. Int. Soc. Sports Nutr.*, vol. 15, no. 1, Oct. 2018, doi: 10.1186/s12970-018-0255-6.
- [3] E. L. do Carmo *et al.*, "Stability of spray-dried beetroot extract using oligosaccharides and whey proteins," *Food Chem.*, vol. 249, pp. 51–59, 2018, doi: 10.1016/j.foodchem.2017.12.076.
- [4] T. Clifford, G. Howatson, D. J. West, and E. J. Stevenson, "The potential benefits of red beetroot supplementation in health and disease," *Nutrients*, vol. 7, no. 4. MDPI AG, pp. 2801–2822, Apr. 14, 2015, doi: 10.3390/nu7042801.
- [5] S. Mutiara Novatama, E. Kusumo, and D. Supartono, "Identifikasi Betasianin dan Uji Antioksidan Ekstrak Buah Bit Merah," *Indo. J. Chem. Sci.*, vol. 5, no. 3, pp. 217–220, 2016, [Online]. Available: <http://journal.unnes.ac.id/sju/index.php/ijcs>.

- [6] M. L. Urso and P. M. Clarkson, "Oxidative stress, exercise, and antioxidant supplementation," *Toxicology*, vol. 189, no. 1–2. Elsevier Ireland Ltd, pp. 41–54, Jul. 15, 2003, doi: 10.1016/S0300-483X(03)00151-3.
- [7] S. A. Guaraldo *et al.*, "The effect of low-level laser therapy on oxidative stress and functional fitness in aged rats subjected to swimming: an aerobic exercise," *Lasers Med. Sci.*, vol. 31, no. 5, pp. 833–840, Jul. 2016, doi: 10.1007/s10103-016-1882-2.
- [8] K. L. Jonvik, J. W. Van Dijk, J. M. G. Senden, L. J. C. Van Loon, and L. B. Verdijk, "The effect of beetroot juice supplementation on dynamic apnea and intermittent sprint performance in elite female water polo players," *Int. J. Sport Nutr. Exerc. Metab.*, vol. 28, no. 5, pp. 468–473, Sep. 2018, doi: 10.1123/ijsnem.2017-0293.
- [9] J. Oskarsson and K. McGawley, "No individual or combined effects of caffeine and beetroot-juice supplementation during 1 submaximal or maximal running 2 3," 2018.
- [10] J. L. Flueck, A. Bogdanova, S. Mettler, and C. Perret, "Is beetroot juice more effective than sodium nitrate? - The effects of equimolar nitrate dosages of nitrate-rich beetroot juice and sodium nitrate on oxygen consumption during exercise," *Appl. Physiol. Nutr. Metab.*, pp. 1–29.
- [11] S. V. Gokhale and S. S. Lele, "Dehydration of red beet root (*Beta vulgaris*) by hot air drying: Process optimization and mathematical modeling," *Food Sci. Biotechnol.*, vol. 20, no. 4, pp. 955–964, 2011, doi: 10.1007/s10068-011-0132-4.
- [12] J. M. Peake, K. Suzuki, and J. S. Coombes, "The influence of antioxidant supplementation on markers of inflammation and the relationship to oxidative stress after exercise," *J. Nutr. Biochem.*, vol. 18, pp. 357–371, 2007, doi: 10.1016/j.jnutbio.2006.10.005.
- [13] U. S. D. of Agriculture, "USDA National Nutrient Database for Standard Reference, Release 26," 2011. [Online]. Available: <http://ndb.nal.usda.gov/>.
- [14] B. Singh and B. S. Hathan, "Process optimization of spray drying of beetroot Juice," *J. Food Sci. Technol.*, vol. 54, no. 8, pp. 2241–2250, 2017, doi: 10.1007/s13197-017-2659-8.
- [15] M. Kaimainen, O. Laaksonen, E. Järvenpää, M. Sandell, and R. Huopalahti, "Consumer acceptance and stability of spray dried betanin in model juices," *Food Chem.*, vol. 187, pp. 398–406, 2015, doi: 10.1016/j.foodchem.2015.04.064.

Sports Talents Selection of Early-Age Athletes in Central Java using Natural and Scientific Methods

Soedjatmiko¹, Wahadi²
{soedjatmiko@mail.unnes.ac.id¹, wahadipssi@mail.unnes.ac.id²}

Universitas Negeri Semarang, Semarang, Indonesia¹²

Abstract. This study aims to obtain data on early age athletes' sports talents in Central Java. Researchers strive to collect these data with natural methods, and scientific methods follow the results of natural methods. Then, the researchers mapped the talents of early-age athletes based on the region's potential in Central Java. Based on the data, data on junior athletes in Central Java were 285 athletes. They consisted of 173 men and 112 women, coming from 25 leading sports in Central Java. Furthermore, from 285 sports talented athletes, a natural selection test was conducted. The natural selection results obtained as many as 251 sports talented athletes. The brand consists of 151 male athletes and 100 female athletes. A scientific selection test was held. From the scientific selection, 230 athletes who were declared as talented athletes of sports were selected as a result of natural and scientific selection.

Keywords: sports talent, early-age athletes, natural and scientific methods.

1 Introduction

Sports talent scouting is an effort to find athletes who are expected to have high achievements. The talent scouting process does not stop until the discovery of prospective athletes. Scouting and early guidance must be considered as continuous processes.

The identification of early age sports talent is divided into three steps, namely: 1). Identification of talent, 2). Talent Selection, 3). Talent development [1]. Talent identification is a screening of the potential owned by children or adolescents through physical, physiological, and motor skills test to identify the abilities of their sports talents. The results are used to estimate whether the child or adolescent will succeed in training and obtain the highest performance.

Talent selection is screening for young athletes (children and adolescents) who have participated in certain sports that are carried out through physical, physiological, and motor skills tests. It functions to select the abilities and skills owned by these athletes in the sports, so they can develop it until they succeed. Talent development is

a process of giving treatment to a potential athlete in the sport that is occupied according to his talent.

The optimal performance is only possible if the athlete has the potential or talent that is quite ideal—handled by professional trainers with the application of directed, systematic, and valid coaching methods. The consequences of this need to be sought or filtered talent through talent monitoring, marketing, nursery, education, and training in sports achievements. 60% of athletes' top achievements are determined by talent, hard work, high discipline from the sportsmen themselves [2].

In general, talent can be interpreted as something that is owned by someone when he was born. He can manifest through heredity and personal factors that are obtained from a mixture of two cells originating from the father and mother by genetic law. This heredity can be different from one individual to another in a family. At the same time, the person is something that exists, something obtained and can differ from one individual to another, including siblings [3].

1.1 Characteristics of Talented Children in Sports

According to Bloom, a child's sports career is divided into three stages: the initial stage, the developing stage, and the perfect stage. The steps will be described as follows:

1.2 Initial Phase

. At this stage, children involved in sports have the talent to show a very loving nature of the sport. Love is also shown by being a fan of athletes who excel in the sport. At this stage, the trainer should not emphasize mastery of techniques but still maintain that children can practice happily. Trainers and parents in giving rewards must be based on the process, not results.

1.3 Development Stage

. At this stage, children begin to go crazy over occupied sports. The child already feels that he can be an athlete and not just a participant. The athlete's motivation and dedication increases; he even strives to improve his skills to improve. The child's orientation changes to the achievement of his achievements and interests to deepen the knowledge of the practice that is practiced. Athletes should be trained by coaches who are more skilled and have emotional connections with their athletes. Parents are expected to provide moral and financial support so that their performance continues to improve.

1.4 Stage of Perfection

. The Perfection Stage is obtained after the needs at the developmental stage have been fulfilled, and achievements continue to increase. At this stage, the practiced sport dominates his life, and the athlete spends his time and effort to achieve the highest achievements. The role of parents is not too significant because their children are already more independent. The coach will always demand to always excel from time to time. Relationships with trainers can be more positive or negative, depending on the trainer's approach.

Table 1. Talented Children in Sports' Characteristic Model According to Bloom.

No	Individual	Career Stages		
		Beginning	Developing	Perfect
1	Performance (athlete/child)	Cheerful, happy, spirited feeling special	Passionate, dedication	Obsession, responsibility
2	Mentor (Coach)	Kind, full of loved, orientation to process	Strong, decisive, respectful, skilled, provide positive challenges	Fear / be respected, bring success, be emotionally bound
3	Parents	Share joy and enthusiasm, supportive, positive	Willing to sacrifice (including financial), limit children's activities	

1.5 Talent Identification

The program of identifying talented athletes has been a primary concern of countries with rapidly developing sports achievements. As an illustration, the State of East Germany at the 1968 Olympics in Mexico won 9 gold medals. Eight years later, after the country ran an intensive talent identification program, he achieved success at the 1976 Olympics in Montreal by winning 47 gold medals. Likewise, in facing the Sydney Olympics in 2000, Australia has implemented a program of identifying and developing talented athletes through schools with the science and technology approach. It has been proven that Australia is able to occupy the top 4 of the world in the Sydney Olympics after the United States, Russia, and China. The program of identifying talented athletes in these countries has been developed and implemented to support adequate resources. It is not only funding from the government and the community, but also expert support through a cross-cutting and interdisciplinary scientific approach.

The identification of talented athletes must start from the underlying assumption that each individual is given the same opportunity to participate in various sports activities and develop his potential to reach peak performance. Identification and selection must be made validly and reliably so that the results can be used to predict the athlete's expected performance.

It was realized that bringing up high-achieving athletes was a long and complicated process. In addition to the talent deposition that exists in an athlete, the athlete's success is also determined by how the athlete's potential is nurtured and developed through a conducive training process. Talent identification aims to predict with the optimum chance of success to follow and complete the training process to reach the peak achievement.

1.6 Sports Talent Selection Model

Identifying talented athletes can be done in two ways, namely: (a) natural models and (b) scientific models.

- a) Natural model is a selection made naturally. This model adheres to the belief that an athlete who chooses a particular branch of sport matches his talent. This belief is undoubtedly true, and there is a possibility of being wrong. It means that the athlete can be high achievers, and vice versa can be an athlete whose performance is slow because the choice of the sport that he is doing is not following the real potential in him.
- b) A scientific model is a selection model for prospective athletes by comprehensively applying scientific rules. Athletes are identified based on standard measurements such as body size, heart-lung conditions, and psychological conditions, and are performed by people who have the ability in their field. The determination of specific measurements needs to be adjusted to the specifications of the sport. For example, sports that require height/weight (such as basketball, volleyball, and throwing numbers) certainly cannot be compared to sports that require speed, reaction time, coordination, and strength (such as: sprinting, judo and jumping)

Table 2. Battery Talent Sports Identification Test

Measured Aspects	Test Form	Unit of Measure
Body Shape and Size	1. Height	Centimeter
	2. body weight	Kilogram
	3. Sitting height	Centimeter
	4. Arm span	Centimeter
Physical Ability		
- Eye-hand coordination	1. Throw catch	Frequency
- Arm muscle strength	2. Throw the basketball	Meters
- Leg muscle explosive power	3. Jump straight	Centimeter
- agility	4. Run back and forth	Seconds
- speed	5. Run 40 m	Seconds
- aerobic capacity	6. Multi-stage run	Series-level

1.7 Early Age Sports

Early age children, according to growth and development, is the age period between 6-14 years [4]. This period is a critical period to determine the achievements in the future. At this age, it is a potential that has the potential for coaching so that in the future, it will produce the highest possible achievements.

The age of the beginning of the sport is different from one branch to another. The difference is based on the specifications of the sport that is occupied. Early age is also based on the growth and development of early-age athletes. Starting a too early sport will cause injury, growth disturbance, and even boredom and drop out on the

sport branches. Conversely, delays in starting in sports will have difficulty getting top achievements.

Sports talent scouting must consider the specific branch of sport. Physical components, height, skills, and psychological sports are different from one another. The age of the beginning of the sport is different from one branch to another. Those differences are based on the specifications of the sport that is occupied. Below is presented a table that can be used as a basis for determining the age of beginning of specialization and the peak achievement of athletes in each sport [5].

Table 3. Starting Age of Training, Specialization and Peak Achievement

No	Sports Branch	Starting Age of Training	Specialization	Peak Achievement
1	Athletic	10-12	13-14	18-23
2	Basketball	8-9	10-12	20-25
3	Boxing	13-14	15-16	20-15
4	Bicycle Racing	14-15	16-17	21-24
5	Platform Diving	6-7	8-10	18-22
6	Fencing	8-9	10-12	20-25
7	Female Gymnastic	6-7	10-11	14-18
8	Male Gymnastic	6-7	12-14	18-24
9	Rowing	12-14	16-18	22-24
10	Football	10-12	11-13	18-24
11	Swimming	3-7	10-12	16-18
12	Tennis	6-8	12-14	22-25
13	Volley	11-12	14-15	20-25
14	Weightlifting	11-13	15-16	21-28
15	Wrestling	13-14	15-16	24-28
16	Badminton	8-9	14-15	18-24
17	Hockey	12-14	16-18	22-25
18	Softball	10-12	14-16	18-24
19	Archery	11-12	17-18	20-28
20	Pencak silat	10-11	15-16	18-22
21	Hand Ball	12-13	15-16	18-24
22	Table Tennis	7-8	10-12	18-24
23	Water Polo	12-13	15-16	18-25
24	Horse Riding	13-15	17-18	20-25
25	Sailing	12-13	15-16	18-24
26	Judo	12-13	15-16	18-25
27	Karate	12-13	15-16	18-25

2 Methods

Researchers used sports talent selection for early athletes to obtain data on potential early athletes in Central Java. In scouting early childhood, talent is known for identifying talent, talent selection, and sports talent development for young athletes.

Talent identification is a screening (Screening) conducted on children and adolescents through a series of physical, physiological, and motor skills tests as an instrument of selection to identify children who are sports talented so that they can achieve peak performance [6].

The general objective of identifying children and adolescents' talents is to increase the standard of sporting achievement, namely to increase the standard of achievement in higher competitions, to maximize the talents possessed by athletes in certain sports to be more successful in higher competitions. Specifically, the objectives of talent identification are: 1) applying the talents of children and adolescents with the opportunity to develop their skills. 2) optimistic about all individuals on the success of sports achievements, 3). Increase sufficient stimuli for ongoing participation 4). Control the discrepancy of sports occupied by children and adolescents, thereby reducing the possibility of injury when exercising.

Talent selection can be made in three ways: natural ways, scientific ways, and based on regional potential. The natural way is an approach to identify the child's talents through natural or natural steps of the child's development during sports activities. Through this natural selection, it is assumed that children's sports talent is obtained from sports treatment, which is often accidentally performed by children during their development. Weakness in natural talent selection always experiences delays and evaluates individual performances.

Scientific approach is an approach to identify children's talents by selecting the prospects of natural abilities that children have had directed at sports that are following their potential and carried out in the form of scientific tests by scientists.

Regional potential based talent selection is a selection based on the potential of the area where the child or adolescent lives. The potential in question can be in the form of natural conditions in the area, the social environment in the area, the sporting traditions in the area concerned, and the influence of the informal environment and peers.

To get perfect results, the researchers tried to combine the three tests into one series of tests. The goal is to supplement the shortcomings of one method of determining sports talent with another method, also in order to maximize the advantages of one method to be used in combination methods.

To get the ideal sample is to research on multi-event sports events. Events that are attended by athletes ages 8-12 years or elementary school age and are multi-event are the most appropriate holding of Student Sports Week. Almost all student sportsmen attended this activity in Central Java.

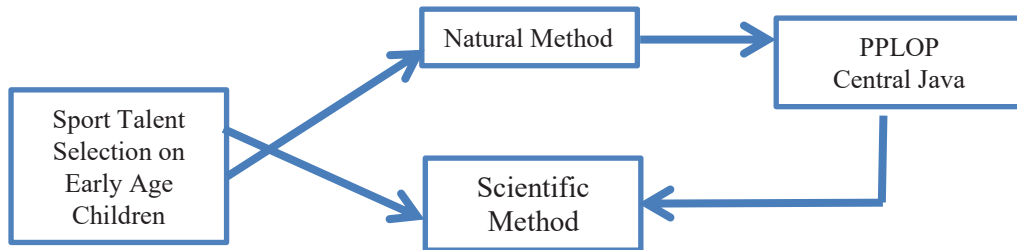

Fig. 1. Research flowchart

The research identified early-age sports talent throughout Central Java. Researchers try to naturally select talents possessed by early childhood. The result is a natural test then proceed with a scientific test. The scientific test used is test 1) Anthropometric quality test 2). Predicted height test for children when they are adults.

The type of research used is qualitative research. While the research design used is Sequential Exploratory Design. Sequential Exploratory Design is an analysis where data collection and data analysis are qualitatively carried out as a prefix for the implementation of the analysis, further data collection and subsequent data analysis is done quantitatively. Sequential Exploratory Design was chosen as a research procedure when researchers need to make an instrument, or existing instruments are considered to be inappropriate or inappropriate so this research needs to review new research instrument.

3 Results and Discussions

3.1 Natural Selection Results

From all junior athletes in Central Java, there were 285 athletes from all of Central Java. They consisted of 173 men and 112 women. Each comes from 25 sports which are the main sports in Central Java.

3.2 Scientific selection results

Furthermore, from 285 sports talented athletes, a natural selection test was conducted. The natural selection results obtained as many as 251 sports talented athletes. The brand consists of 151 male athletes and 100 female athletes. From the results of the natural selection then a scientific selection test was held.

From scientific selection, we got data from 251 athletes then tested with scientific tests with 20 meter running tests, sit and reach tests, dynamometer grip tests, dynamic balance, sit ups, push-ups, pull ups, vertical jumps, and vo2 max.

The results of scientific selection of talented athletes in Central Java can be seen in the following table:

Table 4. The Scientific Selection's Result of Talented Athletes in Central Java

NO	Test Result Categories	Total
1	Excellent	3
2	Good	49
3	Enough	111
4	Poor	82
5	Very Poor	6
Total		251

From these results can be displayed in the diagram as below:

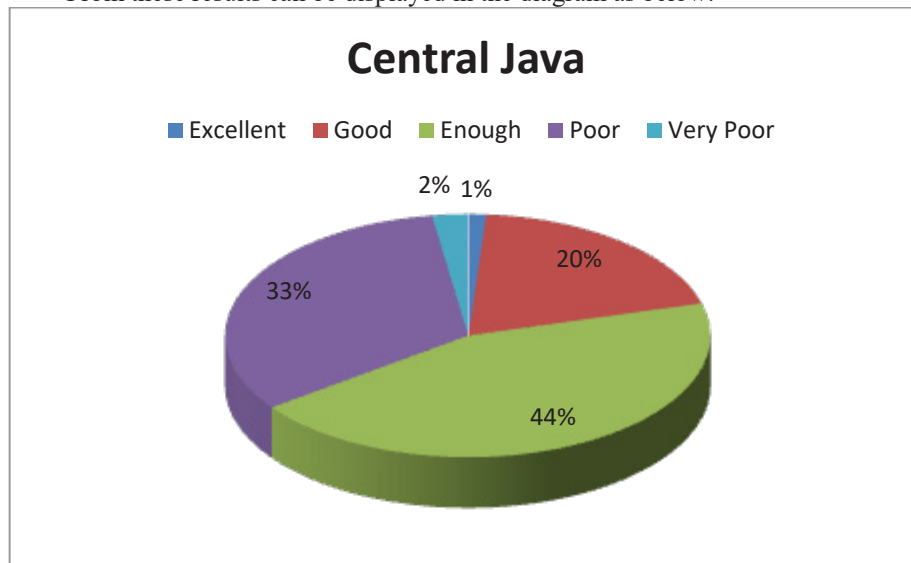
**Fig. 2.** Diagram of The Scientific Selection's Result of Talented Athletes in Central Java

Furthermore, the results of scientific selection can be broken down again based on sex as mentioned below:

Table 5. The Scientific Selection's Result of Talented Athletes in Central Java Based on Sex

No	Categories	Male	Female	Total
1	Excellent	3	0	3
2	Good	37	12	49
3	Enough	76	35	111
4	Poor	34	48	82
5	Very Poor	1	5	6
Total		151	100	251

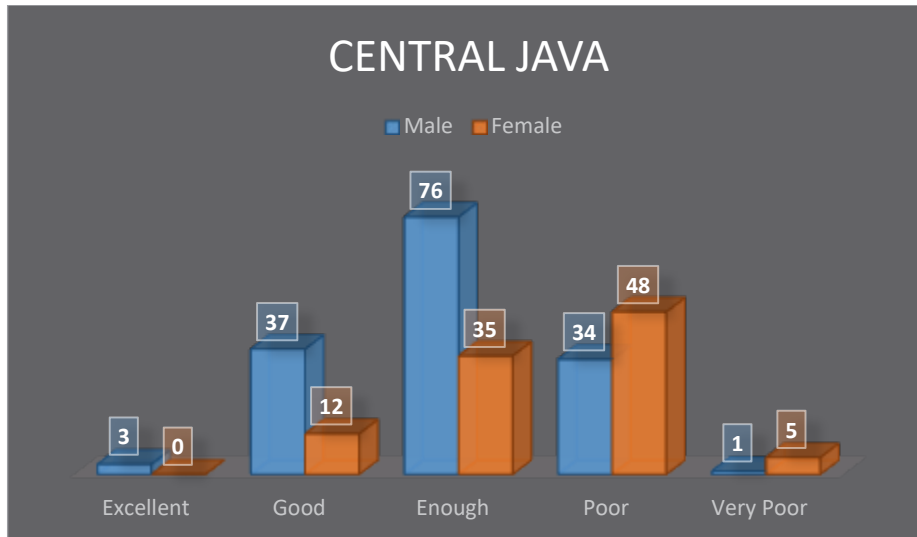

Fig. 3. Chart of The Scientific Selection's Result of Talented Athletes in Central Java Based on Sex

4 Conclusion

From the scientific selection, 230 athletes who were declared as talented athletes of sports were selected as a result of natural and scientific selection. The natural selection results obtained as many as 251 sports talented athletes. The brand consists of 151 male athletes and 100 female athletes. From the results of the natural selection then a scientific selection test was held.

Acknowledgements

Researchers are grateful to those who have helped carry out this research, especially the Head of the Student Sports Education and Training Center, who provided the athletes with the tools to be used as research objects. Also, to the dean of the Faculty of Sports Science who has provided the opportunity for researchers to conduct research.

References

- [1] Australian Institute of Sport. 2005. National Talent Search Program. <http://www.ais.org.au/talent/what/23/01/2020>.
- [2] Undang-undang RI No 3 tahun 2005. Sistem Keolahragaan Nasional. Jakarta: Biro Hukum Kemendpora Republik Indonesia.

- [3] KONI Pusat. 2014. Grand Strategi Pembangunan Olahraga Prestasi Nasional 2014 - 2024. Jakarta: KONI Pusat.
- [4] Litbang KONI. 2014. Analisis Kekuatan, Tantangan, Peluang dan Strategi Indonesia Menyongsong Multi Ajang. Jakarta: KONI Pusat.
- [5] KONI Pusat. 2014. Grand Strategi Pembangunan Olahraga Prestasi Nasional 2014 - 2024. Jakarta: KONI Pusat.
- [6] Undang-undang RI No 3 tahun 2005. Sistem Keolahragaan Nasional. Jakarta: Biro Hukum Kemenpora Republik Indonesia
- [7] Balyi, I., 2005. Sport System Building and Long Term Athlete Development in British Columbia. <http://google.com/24/01/2020>
- [8] Bompa, T.O. 2002. Theory and Methodology of Training, The Key to Athlete Performance (4th ed). Dubuque, Iowa: Kendall/Hunt Publishing Company.
- [9] Kerlinger. N. Fred. 2000. Asas-asas Penelitian Behavioral. Yogyakarta: Gajah Mada University Press.
- [10] Olympic Solidarity. 2010. Manual Administrasi Olahraga. Canada. Roger Jackson & Associates Ltd.
- [11] Masterman, Guy. 2004. Strategic Sports Event Management an International Approach. Amsterdam. Elsevier Butterworth Heinemann.
- [12] Mullin, Bernard J., Hardy, Stephen., Sutton, William, A. Sport Marketing. Canada. Human Kinetics Publisher.

Community Characteristics in COVID-19 Preventive Precautions

Sri Ratna Rahayu¹, Intan Zainafree², Aufiena Nur Ayu Merzistya³,
Tika Dwi Cahyani⁴
{srratnarahayu@mail.unnes.ac.id¹, intan_zainafree@yahoo.com², finamerzistya@gmail.com³}

Universitas Negeri Semarang, Semarang, Indonesia¹²³

Abstract. The number of COVID-19 cases in Indonesia until April 25th, 2020 was 8.211 cases and already tends to increase every day. To reduce the increase in cases, it's important to make efforts to prevent transmission of COVID-19. This study aimed to analyze the relationship between community characteristics with COVID-19 prevention. The study design used cross-sectional with 350 samples that were ≥ 15 years old and domicile in Semarang. Samples were selected by random sampling technique. Data was collected through an online questionnaire and analyzed using the Logistic Regression Test. The result of this research is known that there was a relationship between age, education, and occupation toward social distancing ($p < 0.05$); sex, age, and education level toward mask-wearing ($p < 0.05$); age, education level, and occupation toward using hand sanitizer using ($p < 0.05$) statistically. It can be concluded that community characteristics are related to COVID-19 preventive precautions.

Keywords: COVID-19, characteristic, prevention.

1 Introduction

World Health Organization (WHO) since January 30th, 2020, established Coronavirus diseases (COVID-19) as a Public Health Emergency of International Concern (PHEIC) [1]. This is because COVID-19 is a public health event that is dangerous and raises health risks to other countries through the spread of disease internationally [2]. More than 2,804,796 confirmed COVID-19 cases and 182,100 deaths by April 26th, 2020, in the world [3].

COVID-19 has spread to 186 countries, including Indonesia [4]. A total of 8,211 positive cases were recorded with 1,002 cures and 689 deaths by April 25th, 2020, and these cases are predicted to continue increasing every day [5]. Since January 28th, 2020, the relevant Ministries together with the National Disaster Management Agency (BNPB) set Indonesia in a state of emergency for the COVID-19 epidemic [6], so that efforts were made to immediately handle and prevent COVID-19 transmission so that the spread of the virus would not be more widespread. WHO has provided general guidelines for the prevention and treatment of COVID-19 that can be carried out by

affected countries [7]. Besides, WHO also encourages the public to take preventative precautions to reduce the spread of COVID-19 which is increasingly widespread [8].

Recommendations from WHO are also carried out by Indonesia, where Indonesia has begun to establish regulations and appeals to the public to take steps to prevent COVID-19. These efforts include working from home rules, learning from home, restrictions on community activities, the obligation to wear a mask when leaving the house, washing hands with soap, social distancing, the prohibition of gathering, restrictions on worship in places of worship, health protocols in public places, provision of facilities health for COVID-19, a rapid examination of COVID-19 in some areas, and so on [9].

Prevention efforts are carried out in all parts of Indonesia, one of them is Semarang City. The city of Semarang is the region with the highest COVID-19 case in Central Java [10]. A total of 129 positive cases with 75 deaths and 30 cures [11]. Starting April 27, 2020, the Semarang City established the implementation of Community Activity Restrictions (in *Bahasa*, *Pembatasan Kegiatan Masyarakat: PKM*). The intended PKM is in the form of restrictions on outdoor activities by everyone who lives in the Semarang City area [12].

No vaccine to date requires COVID-19 treatment efforts, one of which is through non-pharmaceutical interventions and several mitigation strategies, one of which is community-based [13]. Effective community-based prevention and control play an important role in controlling COVID-19 in China [14]. This is because the community (human) is the host of COVID-19, in which the COVID-19 virus is transmitted between humans through direct or indirect contact with infected patients [15]. The host is one important component in the degree of public health so that the control and prevention of disease are closely related to the characteristics [16] and behavior of the community itself [17]. Host factors can include age, gender, lifestyle, genetic predisposition, education, professional status, personality. Determinants of individual position in the social hierarchy are the level of education, profession, and income [18]. Therefore we must know the characteristics of the community to develop prevention programs to be more effective.

So from this explanation, it is necessary to develop research that examines the characteristics of the community in the prevention of COVID-19 as an effort to deal with COVID-19. This study aims to analyze the relationship of community characteristics to COVID-19 preventive precautions

2 Method

This study used a cross-sectional study. The independent variables were the characteristics of the community including age, sex, education, and occupation, while the dependent variables were COVID-19 preventive precautions in the form of mask wear, hand washing, hand sanitizer use, and social distancing. A total of 350 Semarang citizens were selected to be sampled in this study with random sampling techniques with criteria: people aged ≥ 15 years old and domiciled in the Semarang City during the COVID-19 pandemic (since March 2020 until Juni 2020). The existence of the COVID-19 pandemic required researchers to continue to do government advice by reducing contact with others, so that data collection is done

through an online questionnaire filled out by respondents online. Then, Data were analyzed by Logistic test on variables with categorical data scales and Mann Whitney Test on numerical data scale variables.

3 Result

A total of 350 people with predetermined criteria are willing to become respondents of this study by filling out an online questionnaire. Based on table 1 it can be seen that from 350 respondents, 30.9% were male. Most of the respondents (51.1%) were diploma/bachelor graduates and only 0.3% were not in school or graduated from elementary school. Meanwhile, 34.6% of respondents did not work, the highest number being in the occupational group. The average age of respondents who took the study was 34.41 years, with a minimum age of 15 years and a maximum age of 69 years. Standard intersection (SD) in the age group is worth 14.17.

Table 1. Frequency distribution of COVID-19 preventive precautions (n=350)

Characteristic	Frequency	Percentage (%)
Sex		
Men	108	30.9
Woman	242	69.1
Education level		
Not school or Elementary school	1	0.3
High School	115	32.9
Diploma/Bachelor	179	51.1
Master or Doctoral	55	15.7
Occupation		
Entrepreneurs	41	11.7
Daily labors	8	1.3
Employees	94	26.9
Government Employees	85	24.3
Farmers/Fishermen	1	0.3
Not work	121	34.6
Characteristic	Mean	Standard Deviation
Age (15 -69 years old)	34.41	14.17

Table 2 shows the proportion of sex, education level, and type of community work in COVID-19 preventive precautions. Prevention of COVID-19 in this study is categorized into 4 categories, namely (1) social distancing actions, (2) actions of wearing masks when traveling out, (3) actions of washing hands, and (4) actions of using hand sanitizers. The results of this study can be seen in the following table.

Table 2. The proportion of characteristic toward COVID-19 preventive precautions (n=350)

Characteristics	Preventive Precautions							
	<i>Social distancing</i>		<i>Mask wearing</i>		<i>Hand washing</i>		<i>Hand sanitizer using</i>	
	No	Yes	No	Yes	No	Yes	No	Yes
Sex								
Men (%)	48 (34.5)	60 (28.4)	6 (66.7)	102 (29.9)	2 (28.6)	106 (30.9)	27 (32.1)	81 (30.5)
Woman (%)	91 (65.5)	151 (71.6)	3 (33.3)	239 (70.1)	5 (71.4)	237 (69.1)	57 (67.9)	185 (69.5)
Education level								
Elementary/High School (%)	20 (14.4)	96 (45.5)	7 (77.8)	109 (32.0)	3 (42.9)	113 (32.9)	38 (45.2)	78 (29.3)
Diploma/Bachelor/Master /Doctoral (%)	119 (85.6)	115 (54.5)	2 (22.2)	232 (68.0)	4 (57.1)	230 (67.1)	46 (54.8)	188 (70.7)
Occupation								
Work (%)	104 (74.8)	84 (39.8)	3 (33.3)	185 (54.3)	4 (57.1)	184 (53.6)	35 (41.7)	153 (57.5)
Not work (%)	35 (25.2)	127 (60.2)	6 (66.7)	156 (45.7)	3 (42.9)	159 (46.4)	49 (58.3)	113 (42.5)

As seen in the table above, in overall and quantity, there were more respondents in the COVID-19 preventive group than in the response group who did not prevent COVID-19. The proportion of men who did not do social distancing (34.5%) was greater than with the proportion of men who did social distancing (28.4%). In the education level group, respondents with Diploma/Bachelor/Master/ Doctoral education level who did not do social distancing had a greater proportion (85.6%) compared to they did social distancing (54.5%). Meanwhile, in the working group, the proportion of working people who did not social distancing (74.8%) was greater than the proportion of working people who did social distancing (39.8%).

Then, for the proportion of men who did not wear masks when leaving the house (66.7%) more than the proportion of men who wore masks when leaving the house (29.9%). In the education level group, it is seen in a quantity that most have worn masks when leaving the house. Even so, the proportion of people with Elementary/High School education level who did not wear masks (77.8%) is greater than that of people with Elementary/High School education level who wore masks (32%). Whereas in the workgroup, the proportion of working people who wore masks when doing activities outside the home (54.3%) is greater than not wearing masks when doing activities outside (33.3%).

In COVID-19 preventive precautions by washing hands, the number of respondents in the education level group did hand washing more than the number of groups who did not wash their hands. Similarly, the proportion, men who washed their hands (30.9%) were greater than men who did not wash their hands (28.6%). The proportion of Elementary/High School graduates who did not wash their hands (42.9%) was

greater than the proportion of Elementary/High School graduates who washed their hands (32.9%). As with the workgroup, the proportion of working people who did not wash their hands (57.1%) was greater than the proportion of working people who washed their hands (53.6%).

The proportion of men who did not use hand sanitizer (32.1%) was greater than the proportion of men who used hand sanitizer (30.5%). Meanwhile, in the education level group, the proportion of diploma/bachelor/master/doctoral graduates who used hand sanitizers (70.7%) was greater than the proportion of diploma/bachelor/master/doctoral graduates who did not use hand sanitizers (54.8%). The proportion of working people who used hand sanitizers (57.5%) is greater than the proportion of working people who did not use hand sanitizers (41.7%).

Table 3. The relationship between community characteristics with social distancing

Characteristics	Significance	Prevalence Ratio (PR)	Confidence Interval (95% CI)
Sex	0.150	0.68	0.41 – 1.15
Age (years)	<0.01*		
Education level	<0.01*	0.20	0.12 – 0.35
Occupation	<0.01*	4.49	2.80 – 7.20

*significant (p<-0.05)

Based on the relationship table above it is known that the significance value (p-value) in the age, education level, and occupation group were less than 0.05 (p<0.01). Then there was a relationship between age, education level, and occupation on COVID-19 preventive precautions by conducting social distancing. The prevalence ratio (PR) value of education level was 0.20, which means that the education level as a protective factor of social distancing behavior (PR<1). So, diploma/bachelor/master/doctoral graduates had the risk of not doing social distancing 0.2 times than elementary/high school graduates. Meanwhile, the PR value of occupation was 4.49, which means people who had a job were 4.49 times more at risk of not doing social distancing than people who had no job.

Table 4. The relationship between community characteristics with mask-wearing

Characteristics	Significance	Prevalence Ratio (PR)	Confidence Interval (95% CI)
Sex	0.036*	0.21	0.05 – 0.91
Age (years)	0.006*		
Education level	0.004*	7.45	1.52 – 36.45
Occupation	0.214	0.42	0.10 – 1.71

*significant (p<-0.05)

The result of the analysis of mask-wearing is shown in table 2. There was a relationship between sex and mask-wearing in the community when leaving the house. Evidenced by the p-value <0.05 ($p = 0.036$). Because of the PR value of sex was less than 1, so sex as a protective factor of the mask-wearing. This means that women had the risk of not wearing a mask when going out 0.2 times compared to men. Besides, there was also a relationship between age and the behavior of wearing masks when leaving the house ($p = 0.006$).

For education level, there was a relationship between education level and mask-wearing in the community when leaving the house, with the p-value was 0.004. The PR value of education level was 7.45, so elementary/high school graduates had a 7.45 times greater risk of not wearing a mask when going out than diploma/bachelor/master/doctoral graduates. Unlike occupation, there was no relationship between occupation and mask-wearing in the community because the p-value was 0.214.

Table 5. Table 5. The relationship between community characteristics with hand washing

Characteristics	Significance	Prevalence Ratio (PR)	Confidence Interval (95% CI)
Sex	0.855	1.17	0.23 – 6.25
Age (years)	0.464		
Education level	0.581	1.53	0.34 – 6.94
Occupation	0.854	1.15	0.25 – 5.23

*significant ($p < 0.05$)

In the type of prevention COVID-19, namely washing hands, can be seen in table 6. There was no relationship between community characteristics (sex, age, education level, and occupation) and handwashing behavior. The significance values of all variables were more than 0.05.

Table 6. The relationship between community characteristics with hand sanitizer using

Characteristics	Significance	Prevalence Ratio (PR)	Confidence Interval (95% CI)
Sex	0.679	1.12	0.65 – 1.96
Age (years)	$<0.01^*$		
Education level	0.007*	0.50	0.30 – 0.83
Occupation	0.011*	0.53	0.32 – 0.87

*significant ($p < 0.05$)

Based on table 6, group of age, education level, and occupation had a relationship with hand sanitizer using in community, each p-value in sequence, i.e., <0.01 , 0.007, and 0.011 (<0.05). So The PR value in education level was 0.50, so education level as a protective factor of hand sanitizer using. Same as occupation, the PR value was

0.53. It means that as a protective factor. It can be concluded that diploma/bachelor/master/doctoral graduates had the risk of not using hand sanitizer 0.50 times compared to elementary/high school graduates and people who did not work had a risk of not using hand sanitizer 0.53 times than working people.

4 Discussion

The World Health Organization (WHO) has advised the public to take precautions to prevent transmission of COVID-19. These precautions include washing hands with running water and soap or alcohol-based hand rub, keeping a minimum distance of 1 meter, avoiding crowds, not touching the face area, closing the mouth when coughing/sneezing, staying at home and wearing a mask when leaving the house, and immediately go to the doctor if you experience symptoms of COVID-19 [8]. This action is important for all levels of society to minimize the risk of transmission and spread of the virus to a wider area [19].

Information about COVID-19 prevention can easily be accessed through all media to increase public awareness about COVID-19 [20], [21]. However, information that can further change people's awareness and behavior can be influenced by several factors, one of which is age [22]. The results of this study show that age is associated with COVID-19 preventive precautions namely social distancing (table 3), wearing a mask when leaving the house (table 4), and using a hand sanitizer instead of water and soap (table 6) statistically, with a statistic the average age of the respondent is 34.41. This can be interpreted as age as an individual factor to do COVID-19 precautions. There is an explanation that supports the results of this study. A person's age will affect the knowledge they receive. In general, the more you age the individual development will increase according to your knowledge and also from the experience you have gained [18]. In addition to knowledge, abilities, and ways of thinking of individuals will also increase [23]. The maturity of individual thinking will affect the actions of these individuals towards events in their environment [24].

Based on the analysis, gender also has a relationship with wearing masks when leaving the house. The behavior of wearing a mask when leaving the house is more done by women than men. Then it can be said that women are more obedient in taking COVID-19 precautions than men. According to WHO, in making risky decisions, men have more courageous behavior than women, including in matters relating to health [25].

Meanwhile, there was also a relationship at the level of education to COVID-19 preventive precautions including, social distancing, mask-wearing, and hand sanitizer using. The higher the individual's education, it will be related to the knowledge gained will be more extensive. This is because more and more information is received so that individuals have more knowledge than the lower level of education [26]. Education will also give a return on individual income, which income will provide convenience in getting wider health information and better health access [27].

There was a statistically significant relationship between occupation and COVID-19 preventive precautions, namely social distancing (table 3) and hand sanitizer using

in the community (Table 6). Social distancing is one of action to keep a distance from others to avoid direct contact such as staying at home and reducing outside activities [28]. However, in reality, some respondents did not do social distancing for various reasons. Most respondents leave the house to work and buy daily necessities in supermarkets, markets, and places to buy other household needs. Based on the result of collecting the data, occupations that were held among the 350 respondents in the study included employees, entrepreneurs, civil servants, fishermen, and day laborers. Some of them said that they were forced to leave home because of demands for work that could not be done at home.

In line with research conducted in the United States, it was explained that low socioeconomic status is associated with a lack of social distancing, where the socioeconomic community is associated with income. Life needs that must be met force them to keep working and doing activities outside the home to earn income for survival [29]. This is also supported by the statement of the Ministry of Health of the Republic of Indonesia where the agency or work that provides services and community needs are not required to do work from home but still adhere to the health protocol [30]. So this is evidence that the type of work can be one of the community factors to take COVID-19 preventive precautions, namely social distancing.

There was no relationship between community characteristics and hand washing. This was because almost all respondents claimed to always wash their hands with soap and running water (table 2). They said that washing hands with soap and running water is always before, during, and after the activity. This makes it possible that there is no relationship between the characteristics of the community with handwashing behavior because most people based on age, occupation, and education have understood the importance of washing hands with soap and running water

5 Conclusion

The results of this study indicate that most people in Semarang City have taken COVID-19 preventive precautions including social distancing, wearing masks when leaving the house, washing their hands, and using hand sanitizers instead of water and soap. It can be seen that there is a relationship between age, sex, level of education, and type of work against COVID-19 preventive precautions. In more detail, there is a relationship between sex and age on behavior in wearing masks; age, master / doctoral education level, and type of work of farmers/fishermen on social distancing; and the age and type of occupation of farmers/fishermen on behavior in using hand sanitizers statistically. So there should be a COVID-19 control and prevention program by taking into account the characteristics of the people in each region. This is because in each region there are differences in the characteristics of the community so that the program is far more effective.

Acknowledgments

Although amid the COVID-19 pandemic that occurred in Indonesia today, which forced researchers to continue carrying out research but by complying with government regulations. So, we extend our thanks to those who have helped the research run. Thank you to the Faculty of Sports Science, Universitas Negeri Semarang for granting permission and funding for this research, so that it can run smoothly according to researchers' expectations. To our respondents, we also thank you for being willing to become respondents of our research and filling out the questionnaire that we gave online through social media.

References

- [1] WHO, "Statement on the second meeting of the International Health Regulations (2005) Emergency Committee regarding the outbreak of novel coronavirus (2019-nCoV)," *World Health Organization*, 2020.
- [2] WHO, "IHR Procedures concerning public health emergencies of international concern (PHEIC)," *Strengthening health security by implementing the International Health Regulations (2005)*, 2020.
- [3] WHO, "Coronavirus disease 2019 (COVID-19) Situation Report - 97," Geneva, 2020.
- [4] CSSE, "Coronavirus COVID-19 Global Cases," Maryland, 2020.
- [5] BNPB, "Situasi Virus Corona," *Badan Nasional Penanggulangan Bencana*, 2020. [Online]. Available: <https://www.covid19.go.id/situasi-virus-corona/>. [Accessed: 20-Mar-2020].
- [6] BNPB, "Surat Keputusan Kepala BNPB Nomor 9.A Tahun 2020 tentang Penetapan Status Keadaan Tertentu Darurat Bencana Wabah Penyakit akibat Virus Corona di Indonesia," Jakarta, 2020.
- [7] WHO, "Country & Technical Guidance - Coronavirus disease (COVID-19)," *Coronavirus disease 2019*, 2020.
- [8] WHO, "Coronavirus disease (COVID-19) advice for the public," *Coronavirus disease (COVID-19)*, 2020.
- [9] Kemenkes RI, "Dokumen Resmi dan Protokol Penanganan COVID-19," *Kesiapsiagaan Menghadapi Infeksi COVID-19*, 2020. .
- [10] Dinas Kesehatan Provinsi Jawa Tengah, "Peta Sebaran Kasus COVID-19 di Jawa Tengah," Semarang, 2020.
- [11] Dinas Kesehatan Kota Semarang, "Informasi Coronavirus (COVID-19) Semarang," Semarang, 2020.
- [12] Mayor of Semarang, "Keputusan Walikota Nomor 443/417 Tahun 2020 Tentang Pemberlakuan Pelaksanaan Pembatasan Kegiatan Masyarakat Dalam Rangka Percepatan Penanganan Corona Virus Disease 2019 (COVID 19) Di Kota Semarang," Semarang, 2020.
- [13] D. L. Heymann and N. Shindo, "COVID-19: What is Next for Public Health?," *Lancet*, vol. 395, no. 10224, pp. 542–545, 2020.
- [14] S. Li, Z. Ye, Q. Wei, C. Du, and C. He, "The residents' mental health status and community's role during COVID-19 epidemic: a community-based cross-sectional study in China," *BMC Public Heal. (not Comple. peer Rev.)*, pp. 1–16, 2020.
- [15] R. R. Dangi and M. George, "A Review on Theories and Models of Disease Causation for COVID-19," 2020.
- [16] N. I. Nii-trebi, "Emerging and Neglected Infectious Diseases: Insights, Advances, and Challenges," *Biomed Res. Int.*, vol. 2017, pp. 1–15, 2017.

- [17] S. Notoatmodjo, *Kesehatan Masyarakat Ilmu dan Seni*. Jakarta: Rineka Cipta, 2007.
- [18] S. Notoatmodjo, *Konsep Perilaku Kesehatan. Promosi Kesehatan: Teori dan Aplikasi Edisi Revisi 2010*. Jakarta: Rineka Cipta, 2010.
- [19] WHO, "Key considerations for repatriation and quarantine of travelers in relation to the outbreak of novel coronavirus 2019-nCoV," *Article*, 2020.
- [20] Kemenkes RI, *Pedoman Pencegahan dan Pengendalian Coronavirus Disease (COVID-19)*. Jakarta: Keme, 2020.
- [21] H. Ardiyanti, "Komunikasi Media Yang Efektif Pada Pandemi Covid-19," *Pus. Penelit. Badan Keahlian DPR RI*, vol. 12, no. 7, p. 30, 2020.
- [22] S. A. R. Al-Dubai, K. Ganasegeran, A. M. Rahman, M. A. Alshagga, and R. Saif-Ali, "Factors Affecting Dengue Fever Knowledge, Attitudes and Practices among selected Urban, Semi-urban and Rural Communities in Malaysia," *Southeast Asian J. Trop. Med. Public Heal.*, vol. 44, no. 1, pp. 37–49, 2013.
- [23] S. Notoatmodjo, *Pendidikan dan Perilaku Kesehatan*. Jakarta: Rineka Cipta, 2003.
- [24] D. Montung, "Hubungan Antara Karakteristik Individu, Pengetahuan, Sikap Dengan Tindakan Masyarakat Dalam Pencegahan Demam Berdarah Dengue Di Wilayah Kerja Puskesmas Kolongan Minahasa Utara," Sam Ratulangi University, 2012.
- [25] Lindawati, B. Miradwiyana, and Sumiati, "Faktor-Faktor Yang Mempengaruhi Perilaku Merokok SiswaSiswi SMP Di Daerah Jakarta Selatan Tahun 2011," *J. Heal. Qual.*, vol. 2, no. 4, pp. 189–200, 2012.
- [26] A. P. M. Gomes *et al.*, "Relationship between patient's education level and knowledge on oral health preventive measures," *Int. Dent. Med. J. Adv. Res.*, vol. 1, no. 1, pp. 1–7, 2015.
- [27] E. Zimmerman and S. H. Woolf, "Understanding the Relationship Between Education and Health," *NAM Perspect.*, vol. 4, no. 6, 2014.
- [28] Social Science in Humanitarian Action, "Compliance with physical distancing measures for COVID-19 and implications for RCCE in Eastern and Southern Africa," 2020.
- [29] N. M. Kavanagh, R. R. Goel, and A. S. Venkataramani, "Association of County-Level Socioeconomic and Political Characteristics with Engagement in Social Distancing for COVID-19," *Peer-review*, pp. 1–8, 2020.
- [30] Ministry of Health, "Peraturan Menteri Kesehatan Republik Indonesia Nomor 9 Tahun 2020." Ministry of Health, Jakarta, pp. 1–28, 2020.

The Application of FIFA 11+ Injury Prevention Program on Youth Football Club in Semarang City

Sri Sumartiningsih¹, Sugiharto², Jens Eiberger³, Anggit Risdiyanto⁴, Ashril Yusof⁵
 {sri.sumartiningsih@mail.unnes.ac.id¹, sgh@mail.unnes.ac.id²,
 jenseiberger.sportscience@hotmail.com³}

Universitas Negeri Semarang, Semarang, Indonesia^{1,2,4,5}
 Germany Fitness and Football Coach, Munich, Germany³

Abstract. To determine the effectiveness of FIFA 11+ kids as an injury prevention program in male youth football players. In addition, this study will evaluate the implementation of FIFA 11+ as warming up and injury prevention for the youth football club. The quasi experimental and descriptive survey study design was conducted in this study. 24 football clubs in Semarang were observed and analyzed using interviews and questioner. From 24 football clubs, just 20 football clubs have kid's teams between the ages of 9 and 12 in January 2018-June 2020. The total youth athlete is 980 kids. The average time each warming up is 15-20 minutes. The rate of injury during a competition in each game base on how many athletes were injured was fifty. The coach age was sufficient for implementing the program—the coach's license was also an active variable for the success injury prevention program in their athletes.

Keywords: warming up, injury prevention, kids, football

1 Introduction

Football is the most popular sport worldwide [1]. The percentage risk of injury incidence at football during matches was higher than in training [2]. Lower limb and thigh strain was common injury location and dominant muscle injury during tournament and training session [3].

FIFA Marc makes protocol warming up called FIFA 11+ to reduce injury percentage [4]. Various research found a positive effect of the FIFA 11+ program to the athletes [5][6][7][8]. The warming up program performed seven exercises for 15-20 minutes [9]. The exercises are focus on three exercises for unilateral and dynamic stability on the inferior extremity, three exercises for whole body strength and one exercises for falling technique [9].

The effectiveness of warming up the FIFA 11+ program was investigated. Numerous studies found that the FIFA 11+ reduced risk of injury inferior extremity, en-

hanced performance, and physical attributes in football players [4][5][6][8][9][10]. The program positively useful reduce injury rate of 20-50% in football players [11][12]. In Indonesia, a limited study about injury prevention focus on implementing FIFA 11+ in football clubs for youth football players. Therefore, this study aims to investigate the implementation of the FIFA 11+ warming up a program in Semarang football clubs for kids 9 to 12 years old.

2 Methods

A descriptive survey study design was conducted to assess the implementation of FIFA 11+ on Semarang city football clubs [13]. Twenty-four of football clubs in Semarang was recorded. The inclusion criteria were active football clubs and have a program for kids 9 to 12 years old, performed the training program minimum 2 times a week taken part as a participant in this study.

Before data collection, an online webinar meeting held to define the FIFA 11+ program, warming up exercise protocol to injury prevention in athletes. One of the researchers as speakers and explain the application to the coach, and the others supervised the coach training program on football club was used. The coach understand which is FIFA 11+ warming up program and usual warming they usually did.

Assessment for data collection, the coach asked to filled the questioner about the implementation of FIFA 11+ in youth football athletes. The warming up of FIFA 11+ exercise program was implemented during their coaching in 2018-2020.

The FIFA 11+ is an extensive warm-up program with six running exercises at the starting and three exercises to activate the cardiovascular system at the finishing, and six specific preventive exercises especially on core and leg strength, balance and agility with three progressive levels for each exercise, as well as inferior extremity and trunk alignment cues, and it takes for 20-25 minutes' complete program [4][6][8][14].

Data were analyzed using the statistical package for the social sciences (SPSS) version 20. For data analysis to describe the descriptive implementation program FIFA 11+ in Semarang city Football clubs.

3 Results and Discussions

There were on percentage of the active football clubs and have a program for kids.

Table 1. Characteristic of Semarang city football clubs, n=24

Variable Category	Percentage
Active football club	90%
Non active football club	10%
have a training program for kids 9 to 12 years old	83%
The training program for kids > 3 years	83%
The training program for kids < 2 year	17%
The club ever join the tournament in 2018-2020	87.5%
Followed the tournament > 6 times/year	62.5%
Followed the tournament 3-5 times/year	30%
Followed the tournament <2 times/year	8.5%
The exercise frequency (> 3 times/week)	62.5%
The exercise frequency 2-3 times/week	37.5%
The rate frequency of injury in each tournament > 4 athletes	50%
the rate frequency of injury each tournament 2-3 athletes	35%
the rate frequency of injury each tournament <2 athletes	15%
The duration of warm up program each training < 20 minutes	50%
The duration of warm up program each training 10-20 minutes	45%
The duration of warm up program each training < 10 minutes	5 %
The coach applied FIFA 11+ on warming up	8.3%
The coach applied usual warming up	91.7%

Table 2. The percentage Club with kids' football program n=980

Kids Age Program in Semarang Football club	Percentage
9 years	24%
10 years	29%
11 years	24%
12 years	22%

Table 3. The age percentage of the Coach Semarang city football club n=80

Age (year)	Percentage
< 25	20%
25-35	35%
35-45	35%
>45	10%

Table 4. The Football Coach License n=80

Name of License	Percentage
No license	13%
D	67%
C AFC	13%
B	8%
A AFC	0%
Pro AFC	0%

This study aimed to investigate the implementation of the FIFA 11+ warm-up injury prevention program on Semarang city football clubs. The study found that only two clubs which applied the FIFA 11+ warm-up program for injury prevention. The average coach age who applied the FIFA 11+ program was 24 years old.

Based on data collection found that the majority of Semarang football clubs have a program for kids. The dominant kid age was ten years old. In this age, they were followed tournament average seven times per year. Fifty percentage injury rate during the performance in the tournament. It is mean the coach not yet applied the FIFA 11+ warm-up injury prevention in training and before the competition.

The FIFA 11+ program proved to reduce injury rates in youth, young, and adult football athletes [4][5][9][10][12][15][16]. The program also helps to enhance the strength and performance of football athletes [6][7][8][10]. The others advantage of FIFA 11+ studied found that the warm-up protocol program increases the agility, dynamic balance, and flexibility [17][18][19][20].

The numerous study proved the effective FIFA 11+ warm-up injury prevention program. The proved study results were a reason the football clubs suggested to follow the program to reduce athletes from injury.

4 Conclusion

The football clubs which followed the FIFA 11+ warm-up program were minimum in Semarang city. The coach age was sufficient for implementing the program—the coach's license was also an active variable for the success injury prevention program in their athletes.

Acknowledgements

We would like to thank Faculty of Sports Science, Universitas Negeri Semarang, Indonesia for the funding.

References

- [1] Association FIdF. FIFA Big Count 2006: 270 million people active in football. FIFA Communication Division. 2007.
- [2] Ekstrand J, Hägglund M, Waldén M. Injury incidence and injury patterns in professional football: the UEFA injury study. *British J. of Sports Med.* 2011;45(7):553-8.
- [3] Ekstrand J, Hägglund M, Waldén M. Epidemiology of muscle injuries in professional football (soccer). *The American J. of Sports Med.* 2011;39(6):1226-32.
- [4] Bizzini M, Dvorak J. FIFA 11+: an effective programme to prevent football injuries in various player groups worldwide—a narrative review. *British J. of Sports Med.* 2015;49(9):577.
- [5] Pomares-Noguera C, Ayala F, Robles-Palazón FJ, Alomoto-Burneo JF, López-Valenciano A, Elvira JLL, et al. Training Effects of the FIFA 11+ Kids on Physical Performance in Youth Football Players: A Randomized Control Trial. *Frontiers in Pediatrics.* 2018;6(40).
- [6] Rössler R, Donath L, Bizzini M, Faude O. A new injury prevention programme for children's football – FIFA 11+ Kids – can improve motor performance: a cluster-randomised controlled trial. *J. of Sports Scien.* 2016;34(6):549-56.
- [7] Zarei M, Namazi P, Abbasi H, Noruzyan M, Mahmoodzade S, Seifbarghi T. The Effect of Ten-Week FIFA 11+ Injury Prevention Program for Kids on Performance and Fitness of Adolescent Soccer Players. *Asian J. Sports Med.* 2018;9(3):e61013.
- [8] Daneshjoo A, Rahnama N, Mokhtar AH, Yusof A. Effectiveness of injury prevention programs on developing quadriceps and hamstrings strength of young male professional soccer players. *J. of Human Kine.* 2013;39(1):115-25.
- [9] Spurrier D. The 11+ Kids' warm-up program performed at least once a week reduces severe and lower extremity injuries in children playing football [commentary]. *J. of Physio.* 2019;65(1):53-.
- [10] Daneshjoo A, Mokhtar AH, Rahnama N, Yusof A. The effects of injury preventive warm-up programs on knee strength ratio in young male professional soccer players. *PloS one.* 2012;7(12).
- [11] Comprehensive warm-up programme to prevent injuries in young female footballers: cluster randomised controlled trial. *Bmj.* 2008;337:a2469.
- [12] Al Attar WSA, Soomro N, Pappas E, Sinclair PJ, Sanders RH. How effective are F-MARC injury prevention programs for soccer players? A systematic review and meta-analysis. *Sports medicine.* 2016;46(2):205-17.
- [13] Cowman S, Björkdahl A, Clarke E, Gethin G, Maguire J, Group EViPR. A descriptive survey study of violence management and priorities among psychiatric staff in mental health services, across seventeen european countries. *BMC health services research.* 2017;17(1):59.
- [14] Akbari H, Sahebozamani M, Daneshjoo A, Amiri-Khorasani M. Effect of the FIFA 11+ programme on vertical jump performance in elite male youth soccer players. *Montenegrin J. of Sports Scien. and Med.* 2018;7(2):17.
- [15] Silvers-Granelli H, Mandelbaum B, Adeniji O, Insler S, Bizzini M, Pohlig R, et al. Efficacy of the FIFA 11+ injury prevention program in the collegiate male soccer player. *The American J. of Sports Med.* 2015;43(11):2628-37.
- [16] Barengo NC, Meneses-Echávez JF, Ramírez-Vélez R, Cohen DD, Tovar G, Bautista JEC. The impact of the FIFA 11+ training program on injury prevention in football players: a systematic review. *Int. J. of Environmental Res. and Pub. Healt.* 2014;11(11):11986-2000.
- [17] Cloak R, Nevill A, Smith J, Wyon M. The acute effects of vibration stimulus following FIFA 11+ on agility and reactive strength in collegiate soccer players. *J. of Sport and Health Scien.* 2014;3(4):293-8.

- [18] Bizzini M, Impellizzeri FM, Dvorak J, Bortolan L, Schena F, Modena R, et al. Physiological and performance responses to the “FIFA 11+”(part 1): is it an appropriate warm-up? *J. of Sports Scien.* 2013;31(13):1481-90.
- [19] Daneshjoo A, Mokhtar AH, Rahnama N, Yusof A. The effects of comprehensive warm-up programs on proprioception, static and dynamic balance on male soccer players. *PloS one.* 2012;7(12):e51568.
- [20] Ayala F, Pomares-Noguera C, Robles-Palazón FJ, del Pilar García-Vaquero M, Ruiz-Pérez I, Hernández-Sánchez S, et al. Training effects of the FIFA 11+ and harmoknee on several neuromuscular parameters of physical performance measures. *Inter.J. of Sports Med.* 2017;38(04):278-89.

Socio-Demographic Characteristics Associated with Loss to Follow Up of Antiretroviral Therapy Among HIV and AIDS Patients in Semarang City, Central Java Province: A Case Control Study

Sutini¹, Widya Hary Cahyati², Sri Ratna Rahayu³, Muchlis Achsan Udji Sofro⁴, Nur Fahanah⁵, Setyo Pramudo⁶, Selamat Hidayat⁷, Tuti Susilowati⁸, Farid Agushybana⁹, Slamet Riyadi¹⁰

{tinihernowo@gmail.com¹, widyahary27@gmail.com², s.ratnarahayu@gmail.com³, muchlis.aus@gmail.com⁴, nurfarhanahams@gmail.com⁵, dr.pramudo2012@gmail.com⁶, hidayat.selamet@gmail.com⁷, iyya_salaman@yahoo.co.id⁸, hybana@gmail.com⁹, justslam@gmail.com¹⁰}

Universitas Negeri Semarang, Semarang, Indonesia¹²³,
Diponegoro University, Semarang, Indonesia⁴⁵⁶⁷⁸⁹,
Katholik Soegijapranata University, Semarang, Indonesia¹⁰

Abstract. : Loss to follow-up (LTFU) of clients from antiretroviral therapy (ART) has a great negative impact on the immunological benefits of ART, and increased acquired immune deficiency syndrome related morbidity and mortality. The purpose of this study was to analyze socio-demographic characteristics related to LTFU among HIV and AIDS patients in Semarang City. A case-control study was carried out at Hospitals and Primary Health Centre. Patients who did not take anti-retroviral for 3 months were defined as LTFU while those regularly take anti retro viral for 3 months became the controls. The total sample of the research were 134 respondents obtained by purposive sampling technique. Chi square and logistic regression tests were performed to analyze factors associated with LTFU. The multivariate analyses showed the most dominant factors that influence with LTFU was education level (OR = 6.27. 95% CI: 2.29, 17.09). Intervention on literacy program should be emphasized to patients who are about to start and during the ART program.

Keywords: Socio-demographic characteristics, Loss to follow up, Antiretroviral Treatment, HIV and AIDS.

1 Introduction

Human immunodeficiency virus (HIV) infection remains the leading cause of morbidity and mortality throughout the world. By the end of 2018, the World Health Organization (WHO) estimated that globally about 37.9 million people were living with HIV (PLHIV) and about 23.3 million (62%) of the PLHIV patients received antiretroviral therapy (ART) [1]. Antiretroviral therapy has significantly reduced mortality and improved the life expectancy of HIV infected patients but the success still critically depends on regular patient follow up [2].

To accelerate epidemic control, the United Nations Joint Program on HIV/AIDS (UNAIDS) launched the 90-90-90 campaign in 2014. One of the targets was to achieve viral suppression among 90% of patients receiving ART by 2020. The other targets were ensuring that 90% of the people living with HIV know their HIV status and 90% of those who are diagnosed with HIV infection receive sustained ART [3].

Treatment as prevention studies have demonstrated effectiveness of ART in preventing new HIV infections [3],[4], [5], [6], therefore, increasing ART coverage has public health benefits including reduction of new HIV infections through reduced community viral loads [7].

Loss to follow up of clients from ART have a great negative impact on the immunological benefits of ART, increased acquired immune deficiency syndrome (AIDS) related morbidity, mortality and hospitalization and it also resulted in serious consequences such as discontinuation of treatment, drug toxicity, treatment failure due to poor adherence and drug resistance[8]. Thus, high rates of LTFU ART from treatment programs pose a serious challenge to program implementers and constitutes an inefficient use of scarce treatment resources[9].

Loss to follow-up (LTFU) defined as not taking ART refill for 3 months or longer from the last attendance for refill and not yet classified as dead or transferred-out [10]. The percentage of loss of follow up in the first year of ARV therapy is an indicator of the success of ART. WHO has a target loss to follow-up in the first year of treatment is <20% [11]. LTFU ART among HIV and AIDS patients associated with ART adherence is a problem in Semarang City. Report on HIV care and ART from Semarang City Health Office from 1995 – 2019, there were 924 PLHIV that LTFU (21%).

Different studies showed that LTFU ART is associated with socio-demographic baseline factors like sex education [12], [13], age [12], [14] level of education [15], [16], [17], [18], [19], marital status [20], [17], employment status [21], [22], [23], [24], distance from the health facility[10], [25], [21], [26].

Study at Dr. Kariadi Hospital in Semarang City by Rosiana in 2014 showed that factors related with patients who stopped ART were due to work or daily activities, lack of counselling and testing clinics, and lack of social support. [27]. Study at Dr. Sardjito Hospital in Yogyakarta Province in 2016 showed that occupation as students, distance between home and health services ≥ 10 km and the use of health insurance were factors that influenced LTFU [28]. Socio-demographic factors including accessibility to services are some of the predictors causing LTFU [29].

2 Method

Design of this study was observational with case-control study. The population was HIV and AIDS patients who were recorded in HIV care, support and treatment services at the primary health centers and hospitals in Semarang City, Central Java Province, Indonesia during 2016-2018 period who adhered on ART and LTFU. Patients who did not take anti-retroviral for 3 months were defined as LTFU while those regularly take anti retro viral for 3 months became the controls. The study samples consisted of 67 cases and 67 controls. The sampling technique was purposive sampling. The independent variables of this study were age, sex, marital status, level of education, employment status, distance from the health facility. The dependent variables of the study was HIV and AIDS patients who are loss to

follow up of ART. Data collection was carried out by interviews using structured questionnaires. Univariate analysis was carried out to describe baseline socio-demographic characteristics of the study subjects using simple frequency distribution. Chi-squared tests were used to measure the significance of differences in socio-demographic characteristic between cases and controls. Multivariate analysis using a logistic regression was performed to identify factors associated with LTFU. The criteria for selection of variables possible for inclusion in multivariable analysis were based on p-value of less than 5%. The strength of association was measured using matched Odds Ratios (OR).

3. Result

Table 1. Baseline of socio-demographic characteristics of study participants in Semarang City

Variables	Total		Cases		Control		P-value
	N	%	N	%	N	%	
Age in years							
18-50	124	92,5	64	95,5	60	85,6	0,189
> 50	10	7,5	3	4,5	7	10,4	
Gender							
Male	89	66,4	44	65,7	45	67,2	0,855
Female	45	33,6	23	34,3	22	32,8	
Educational Status							
Low Education	81	60,4	56	83,6	25	37,3	0,000*
High Education	53	39,6	11	16,4	42	62,7	
Employment status							
Unemployed	61	45,5	19	28,4	42	62,7	
Employed	73	54,5	48	71,6	25	37,3	0,000*
Marital Status							
Unmarried	92	68,7	43	64,2	49	73,1	0,264
Married	42	31,3	24	35,8	18	26,9	
Distance from the health facility							
≤ 5 kms	71	53,0	43	64,2	28	41,8	0,009*
> 5 kms	63	47,0	24	35,8	39	58,2	

*Note: P-value <0.05 is considered significant

At the end of study most (92.5%) of study subjects were aged between 18–50 years and predominantly males (66,4%). Most of study subjects (60.4%) have low educational status. For the employment, 54,5% were employed and 68.7% (n=92) were married. The majority distance from the health facility ≤ 5 km (53%;n=71). The majority (67,2%; n=45) of patients who were LTFU were also males.

When we compared cases with controls, the educational status ($p=0.000$), employment status ($p=0.000$) and distance from the health facility >5 kms ($p=0.009$) were significantly different between cases and controls. A higher proportion of LTFU individuals (83.6%) has less education (no education, primary and secondary education) compared to those who were still in care (16.4%). Higher proportion of LTFU individuals was employed (71.6%) compared to those who were still in care (28.4%). Moreover, a higher proportion of LTFU individuals live more distance from health facility (64.2%) compared to those who were still in care (35.8%) (Table 1).

Table 2. Dominant Socio-demographic characteristics associated with loss to follow up at Semarang.

Multivariat analysis	OR	95% CI		P-Value
		lower	upper	
Educational Status				
Low Education	6.270	2.299	17.098	0,000*
High Education				
Employment status				
Unemployed				
Employed	0.250	0.099	.632	0,003
Distance from the health facility				
≤ 5 kms	1.455	0.578	3.663	0,426
> 5 kms				

* Note: P-value <0.05 is considered significant

As shown in Table 2, the results of the multivariat analysis showed that the low education has six times the odds of being LTFU compared to high education (OR = 6.27 (95% CI: 2.29 - 17.06)). Employed patients has 71% odds of being LTFU compared to those who were unemployed (adjusted OR = 0.25. 95% CI: 0.09, 0.63). Patients who lived ≤ 5 kms from health facility has an adjusted odds ratio for LTFU of 1.45 (95% CI: 0.57-3.66), when compared to patients who lived > 5 kms from health facility.

4. Discussion

4.1 Age

The results of the bivariate analysis showed that the LTFU aged range from 19-50 years but not statistically significant. Age related to a person's psychological condition where psychological factors greatly influence the continuation of ART. Motivation and one's own ability to behave adherently to access to ART are part of the psychological associated with young age [30]. Research at Dr Kariadi Hospital in Semarang showed that patients aged <30 years influence the incidence of loss to follow up [27]. Research at the Amertha Clinic of the Kerti Praja Foundation, Bali, age <32 years affects loss to follow up [31].

4.2 Gender

Gender is one of the factors associated with the occurrence of LTFU ART among people living with HIV and AIDS. The results of this research showed that LTFU ART patients were majority males (65,7%) although it was not statistically significant. LTFU ART was dominant in male [32], [33], [34]. Male patients were more prone to LTFU because they worked or often moved to other region [19], Male patients have variations in mobility and a higher risk of drug abuse that can disrupt with adherence to ART so they are more likely to become LTFU [17]. The condition is different for women who are more likely to visit health care facilities than men to get reproductive services and child health services [34]. Women seek immediate care because they are the primary caregivers in the family and feel they have a greater responsibility to stay healthy. Men are more likely to experience loss to follow up if they have advanced disease, whereas women are more likely to lose to follow up if their CD4 cell counts are high, this shows that loss to follow up in men is likely due to disease that gets worse or death [21].

4.3 Educational Status

Education is also associated with LTFU ART even though education is not in line with one's behavior. The results of the bivariate analysis showed that the LTFU ART patients were mostly has low education which statistically significant ($p=0,000$). The study found OR of 6,2 means that a patient with low education has six times the odds of being LTFU ART compared to a patient with high education. This finding was similar with studies conducted in India ([17], Africa [18] [19], Ethiopia ([15]. Patients with low levels of education find it difficult to understand pre-counseling which includes information of HIV infection, treatment purposes, risks and benefits of therapy, side effects, resistance and comprehensive adherence [35]. Education <16 years is significantly related to loss to follow up. The shorter the education time, the risk of LTFU is also greater. People with low education may have employment-related problems such as not having time to take a rest from work and clinic visits [36]. A retrospective observational study at primary health clinic in Masaka Uganda also showed patients with low education associated with higher LTFU, because patients might have difficulty reading text reminder messages and some communication, information and other educational materials in health facilities that emphasize the need for further care [37]. Patients who have low education are more likely to failure treatment because they do not understand treatment instructions and end in death [38]. Thus, treatment failure was a significant predictor of survival or mortality in HIV patients taking antiretroviral drugs.

4.4 Employment Status

This study found that employment status is related to the incidence of LTFU ($p=0,000$). This study was obtained from respondents who were asked related to financial assistance to access health services and also the feasibility to obtain permission from the

employers to visit health facilities. These constraints caused the approval of PLWHA in accessing care services to be low and end up increasing LTFU.

The results of this study are consistent with studies in Ethiopia that showed 18.2% of HIV patients always skip treatment or do not take medication for busy reasons [22]. Likewise, a study in Kenya explained that 43.8% of HIV patients did not take medication due to busy work factors [21]. Study in Africa explains that LTFU was higher in someone who works every day through the day at work and does not have enough time to come to a health facility for follow up. Because of the nature of their work, they are also more mobile and do not have a constant workplace ending with LTFU [19]. Five LTFU patients (23.8%) said that they did not take ARV drugs because they were busy working and had workplaces outside the city so they could not visit the VCT clinic at RSUP Dr Kariadi [27]. Similarly, the Helen Bygrave et al cohort study in South Africa found treatment failure rates among migrant workers compared with the general population in the first year of treatment, with significant differences observed after one year. Mobility is recognized as the reason why patients became LTFU [39]. Study in Thailand showed that 48% of patients skipped taking drugs in the health service due to work factors and also they are ashamed to their supervisors and the workplace environment when they take ARV. So, work-related obstacles are one of the factors that cause them to disappear and skip doses in the use of ARV[23].

4.4 Marital Status

This study showed that not having partner is higher (64,2%) in the LTFU patients but was not statistically significant. Patients who do not have a partner are more likely to become LTFU because they do not have a support person that is negatively affected by HIV-related stigma [40]. Patients who were unmarried and divorced are mostly LTFU compared to patients who were married [17]; [10]; [32]. Those without partners are less likely to have support system and are thus more likely to be negatively affected by HIV-related stigma and this has proven to be a barrier to adherence and retention in care and treatment [41] [42].

4.5 Distance from the health facility

This study showed distance of residence to health care facility was significantly associated with LTFU ($p = 0.009$). Majority of LTFU patients was live ≤ 5 kms from health facilities. There might be other factors that influence the occurrence of LTFU which related to daily activities. The result of this study was not in accordance with some of the studies which explain that longer distances from health facilities reduced client access because they have to spend more money and time for travel. Although most of HIV services are offered free of charge, indirect costs are a barrier to client retention in care. The same study also states that distance is a predictor of LTFU (> 5 km vs < 1 km: aHR = 2.6 95% CI 1.9-3.7 with $p < 0.01$) [40]. Other studies showed longer distances, long travel times and high transportation costs are the main barriers to access to HIV care ([25], [21], [26]). Longer distance to the clinic is defined by more than 5 kms (aHR = 1.25, 95% CI 1,001.55) [10]. Research in Nairobi- Kenya showed that patients who lived between 5 - 10 kms from the research clinic has a doubled increase in LTFU compared to those who were within 5 kms away (HR = 2.17; 95% CI: 1.09, 4.34) [43].

5. Conclusion

People living with HIV and AIDS who has low education was the major significant factor for LTFU in Semarang City. Focusing on counseling and education will help in increasing knowledge and awareness for HIV patients in adhering to the ART and taking medication according to the doctor's instructions.

References

- [1] World Health Organization, "World Health Organization. Global Health Observatory (GHO) data. HIV/AIDS," <https://www.who.int/gho/hiv/en/>, 2017. .
- [2] M. T. May *et al.*, "Impact on life expectancy of HIV-1 positive individuals of CD4R cell count and viral load response to antiretroviral therapy," *Aids*, vol. 28, no. 8, pp. 1193–1202, 2014.
- [3] UNAIDS, "To help end the AIDS epidemic," *United Nations*, p. 40, 2014.
- [4] E. Raymond *et al.*, "new england journal. SCD-Heft.," *Heart Fail.*, vol. 364, no. 6, pp. 225–237, 2011.
- [5] M. S. Cohen, M. McCauley, and T. R. Gamble, "HIV treatment as prevention and HPTN 052," *Curr. Opin. HIV AIDS*, vol. 7, no. 2, pp. 99–105, 2012.
- [6] B. Grinsztejn *et al.*, "Effects of early versus delayed initiation of antiretroviral treatment on clinical outcomes of HIV-1 infection: Results from the phase 3 HPTN 052 randomised controlled trial," *Lancet Infect. Dis.*, vol. 14, no. 4, pp. 281–290, 2014.
- [7] W. R. Shipley, R. D. Hammer, W. J. Lennington, and W. R. Macon, "Paraffin immunohistochemical detection of CD56, a useful marker for neural cell adhesion molecule (NCAM), in normal and neoplastic fixed tissues," *Appl. Immunohistochem. Mol. Morphol.*, vol. 5, no. 2, pp. 87–93, 1997.
- [8] H. Gesesew, B. Tsehaineh, D. Massa, A. Tesfay, H. Kahsay, and L. Mwanri, "The role of social determinants on tuberculosis/HIV co-infection mortality in southwest Ethiopia: A retrospective cohort study," *BMC Res. Notes*, vol. 9, no. 1, pp. 4–11, 2016.
- [9] M. N. Mberi, L. R. Kuonza, N. M. Dube, C. Nattey, S. Manda, and R. Summers, "Determinants of loss to follow-up in patients on antiretroviral treatment, South Africa, 2004-2012: A cohort study," *BMC Health Serv. Res.*, vol. 15, no. 1, pp. 1–11, 2015.
- [10] C. E. Bekolo, J. Webster, M. Batenganya, G. E. Sume, and B. Kollo, "Trends in mortality and loss to follow-up in HIV care at the Nkongsamba Regional hospital, Cameroon," *BMC Res. Notes*, vol. 6, no. 1, 2013.
- [11] D. A. Tran, A. D. Ngo, A. Shakeshaft, D. P. Wilson, and C. Doran, "Trends in and Determinants of Loss to Follow Up and Early Mortality in a Rapid Expansion of the Antiretroviral Treatment Program in Vietnam : Findings from 13 Outpatient Clinics,"

vol. 8, no. 9, 2013.

- [12] S. B. Asiimwe, M. Kanyesigye, B. Bwana, S. Okello, and W. Muyindike, “Predictors of dropout from care among HIV-infected patients initiating antiretroviral therapy at a public sector HIV treatment clinic in sub-Saharan Africa,” *BMC Infect. Dis.*, vol. 16, no. 1, pp. 1–10, 2016.
- [13] W. Seifu, W. Ali, and B. Meresa, “Predictors of loss to follow up among adult clients attending antiretroviral treatment at Karamara general hospital , Jigjiga town , Eastern Ethiopia , 2015 : a retrospective cohort study,” pp. 1–8, 2018.
- [14] M. A. Assemie, K. F. Muchie, and T. A. Ayele, “Incidence and predictors of loss to follow up among HIV-infected adults at Pawi General Hospital, northwest Ethiopia: Competing risk regression model,” *BMC Res. Notes*, vol. 11, no. 1, pp. 1–6, 2018.
- [15] B. L. Hønge *et al.*, “Loss to follow-up occurs at all stages in the diagnostic and follow-up period among HIV-infected patients in Guinea-Bissau: A 7-year retrospective cohort study,” *BMJ Open*, vol. 3, no. 10, pp. 1–10, 2013.
- [16] P. Z. Akilimali *et al.*, “Disclosure of HIV status and its impact on the loss in the follow-up of HIV-infected patients on potent anti-retroviral therapy programs in a (post-) conflict setting: A retrospective cohort study from goma, Democratic Republic of Congo,” *PLoS One*, vol. 12, no. 2, pp. 1–13, 2017.
- [17] G. Alvarez-uria, P. K. Naik, R. Pakam, and M. Midde, “Factors associated with attrition, mortality, and loss to follow up after antiretroviral therapy initiation: data from an HIV cohort study in India,” vol. 1, pp. 1–8, 2013.
- [18] R. Bucciardini *et al.*, “Predictors of attrition from care at 2 years in a prospective cohort of HIVinfected adults in Tigray, Ethiopia,” *BMJ Glob. Heal.*, vol. 2, no. 3, pp. 1–9, 2017.
- [19] K. G. Marson *et al.*, “Male, Mobile, and Moneyed: Loss to Follow-Up vs. Transfer of Care in an Urban African Antiretroviral Treatment Clinic,” *PLoS One*, vol. 8, no. 10, pp. 2–9, 2013.
- [20] S. T. Meloni *et al.*, “Time-Dependent Predictors of Loss to Follow-Up in a Large HIV Treatment Cohort in Nigeria,” 2012.
- [21] V. Ochieng-ooko *et al.*, “Influence of gender on loss to follow-up in a large HIV treatment programme in western Kenya,” no. April, pp. 681–688, 2010.
- [22] A. Amberbir, K. Woldemichael, S. Getachew, B. Girma, and K. Deribe, “Predictors of adherence to antiretroviral therapy among HIV-infected persons: A prospective study in Southwest Ethiopia,” *BMC Public Health*, vol. 8, pp. 1–9, 2008.
- [23] N. Han, W. Phoolcharoen, and U. Perngparn, “Antiretroviral Drug Taking In Hiv Positive Among Myanmar Migrants In Central Area Of Thailand,” vol. 23, pp. 33–36, 2009.
- [24] N. Mekonnen, M. Abdulkadir, E. Shumetie, and A. G. Baraki, “Incidence and predictors of loss to follow - up among HIV infected adults after initiation of first line anti - retroviral therapy at University of Gondar comprehensive specialized Hospital Northwest Ethiopia , 2018 : retrospective follow up study,” *BMC Res. Notes*, pp. 1–7,

- 2019.
- [25] B. Amuron *et al.*, “Mortality and loss-to-follow-up during the pre-treatment period in an antiretroviral therapy programme under normal health service conditions in Uganda,” *BMC Public Health*, vol. 9, pp. 1–6, 2009.
- [26] E. Losina *et al.*, “Cost-effectiveness of preventing loss to follow-up in HIV treatment programs: A Côte d’Ivoire appraisal,” *PLoS Med.*, vol. 6, no. 10, 2009.
- [27] A. Rosiana and M. Sofro, “Faktor – Faktor Yang Mempengaruhi Lost To Follow-Up Pada Pasien Hiv/Aids Dengan Terapi Arv Di Rsup Dr Kariadi Semarang,” *J. Kedokt. Diponegoro*, vol. 3, no. 1, 2014.
- [28] A. L. Susyanty, R. S. Handayani, and S. Sugiharti, “Keterjangkauan Biaya untuk Mendapatkan Pengobatan pada Anak dengan HIV AIDS dan Infeksi Oportunistik,” *Media Penelit. dan Pengemb. Kesehat.*, vol. 27, no. 3, pp. 161–168, 2017.
- [29] T. M. Berheto, D. B. Haile, and S. Mohammed, “Predictors of Loss to follow-up in Patients Living with HIV / AIDS after Initiation of Antiretroviral Therapy,” vol. 6, no. 9, pp. 453–459, 2014.
- [30] A. Wringe, M. Roura, M. Urassa, J. Busza, V. Athanas, and B. Zaba, “Doubts, denial and divine intervention: Understanding delayed attendance and poor retention rates at a HIV treatment programme in rural Tanzania,” *AIDS Care - Psychol. Socio-Medical Asp. AIDS/HIV*, vol. 21, no. 5, pp. 632–637, 2009.
- [31] D. N. Widyanthini, A. A. S. Sawitri, and D. N. Wirawan, “Analisis Retrospektif Longitudinal: Loss to Follow Up saat Menjalani Terapi Antiretroviral di Yayasan Kerti Praja Bali Tahun 2002-2012,” *Public Heal. Prev. Med. Arch.*, vol. 2, no. 1, p. 81, 2014.
- [32] V. Mugisha *et al.*, “Determinants of Mortality and Loss to Follow-Up among Adults Enrolled in HIV Care Services in Rwanda,” vol. 9, no. 1, pp. 1–9, 2014.
- [33] A. Aliyu *et al.*, “Predictors of loss to follow-up in art experienced patients in Nigeria: A 13 year review (2004-2017),” *AIDS Res. Ther.*, vol. 16, no. 1, pp. 1–9, 2019.
- [34] S. Odafe *et al.*, “Patients’ demographic and clinical characteristics and level of care associated with lost to follow-up and mortality in adult patients on first-line ART in Nigerian hospitals,” *J. Int. AIDS Soc.*, vol. 15, no. 2, pp. 1–9, 2012.
- [35] H. Karcher, A. Omondi, J. Odera, A. Kunz, and G. Harms, “Risk factors for treatment denial and loss to follow-up in an antiretroviral treatment cohort in Kenya,” vol. 12, no. 5, pp. 687–694, 2007.
- [36] S. Krishnan *et al.*, “Incidence rate of and factors associated with loss to follow-up in a longitudinal cohort of antiretroviral-treated HIV-infected persons: An AIDS clinical trials group (ACTG) longitudinal linked randomized trials (ALLRT) analysis,” *HIV Clin. Trials*, vol. 12, no. 4, pp. 190–200, 2011.
- [37] J. Kiwanuka, J. M. Waila, M. M. Kahungu, J. Kitonsa, and N. Kiwanuka, “Determinants of loss to follow-up among HIV positive patients receiving antiretroviral therapy in a test and treat setting: A retrospective cohort study in Masaka, Uganda,” *PLoS One*, vol. 15, no. 4, pp. 1–17, 2020.

- [38] T. Girum, F. Yasin, A. Wasie, T. Shumbej, F. Bekele, and B. Zeleke, “The effect of ‘ universal test and treat ’ program on HIV treatment outcomes and patient survival among a cohort of adults taking antiretroviral treatment (ART) in low income settings of Gurage zone , South Ethiopia,” *AIDS Res. Ther.*, pp. 1–9, 2020.
- [39] H. Bygrave *et al.*, “Trends in loss to follow-up among migrant workers on antiretroviral therapy in a community cohort in Lesotho,” *PLoS One*, vol. 5, no. 10, pp. 3–7, 2010.
- [40] A. S. Hassan, K. L. Fielding, N. M. Thuo, H. M. Nabwera, E. J. Sanders, and J. A. Berkley, “Early loss to follow-up of recently diagnosed HIV-infected adults from routine pre-ART care in a rural district hospital in Kenya: a cohort study,” *Trop. Med. Int. Heal.*, vol. 17, no. 1, pp. 82–93, 2012.
- [41] S. Merten, E. Kenter, O. McKenzie, M. Musheke, H. Ntalasha, and A. Martin-Hilber, “Patient-reported barriers and drivers of adherence to antiretrovirals in sub-Saharan Africa: A meta-ethnography,” *Trop. Med. Int. Heal.*, vol. 15, no. SUPPL. 1, pp. 16–33, 2010.
- [42] M. McGuire *et al.*, “Vital status of pre-ART and ART patients defaulting from care in rural Malawi,” *Trop. Med. Int. Heal.*, vol. 15, no. SUPPL. 1, pp. 55–62, 2010.
- [43] N. J. Conley *et al.*, “Distance from home to study clinic and risk of follow-up interruption in a cohort of HIV-1-discordant couples in Nairobi, Kenya,” *PLoS One*, vol. 7, no. 8, pp. 4–11, 2012.

Student's Compliance in Doing Physical Activities During COVID-19 Pandemic

Sutopo Patriajati¹, Ayun Sriatmi², Arnia Dian Kusuma Devi³

{sutopopatriajati@gmail.com¹, ayunsriatmi@gmail.com², arniadkd@gmail.com³}

Universitas Diponegoro, Semarang, Indonesia^{1,2}
Diponegoro National Hospital, Semarang, Indonesia³

Abstract. The social & physical distancing policies implemented by the government to prevent transmission of COVID-19 force school-age children to carry out various activities at home. Quarantine demands and online models of learning had an impact on children's tendency to static patterns through sitting, playing gadgets, eating, and sleeping. They also neglecting important physical activities that must be carried out to maintain stamina, growth, and health status, such as light exercise and sunbathe in the morning. The health status of students was key to their productivity in the future. The purpose of the study was to analyze the compliance of students from doing physical activity during COVID-19 pandemic and various influencing factors. This is a quantitative study with a cross-sectional approach to 167 students who became the sample of the study. Data collected online with google-form in early May 2020. Data be analyzed with the rank-spearman test. As many as 61.7% of students have good levels of compliance in doing physical activities. Variables of family support, communication interactions, perceived comfort and physical health status were shown to be positively correlated with adherence in doing physical activities ($p < 0.05$). Support and involvement of family members to jointly carry out physical activities on a regular basis could be done through intensive communication with parents to always invite and remind them. Health workers could monitor and evaluate it by involving the role of school teachers.

Keywords: Physical activities; Compliance; COVID-19 pandemic

1 Introduction

Until the beginning of July 2020, the cumulative number of COVID-19 cases in Indonesia reached 57,770 cases with a total of 2,934 deaths. Based on the data in the age group of 6-17 years old or in the school-age group, there was a positive COVID-19 of 5.7% or around 3,293 people with a death of 0.6% or a total of 18 people.[1]

This description indicates that the spread of COVID-19 that occurred in groups of school children could increase if prevention efforts were not carried out properly. Data at the Ministry of Health shows an increase in the number of new cases that continue to increase every day. To anticipate its transmission, the government issued

a Large-Scale Social Restriction (PSBB) policy as PP No. 21 of 2020 concerning Large-Scale Social Restrictions in the Context of Accelerating the Handling of COVID-19 and Minister of Health Regulation No. 9 of 2020 concerning PSBB Guidelines. This policy is known as a form of social and physical distancing.

The COVID-19 pandemic had a significant impact on many sectors of people's lives, one of which was the education sector. Physical distancing policy is also implemented in the educational environment through efforts to eliminate activities in schools. It aims to break the chain of transmission of the virus and struck the curve of COVID-19 cases. The Minister of Education and Culture issued Circular No. 4 of 2020, one of which points to the educational activities in the Coronavirus Disease (COVID-19) emergency period carried out by online methods from home. This policy has implications for students' learning activities that take place online from home.

Based on data from the Ministry of Education and Culture, the total number of students from elementary to high school / vocational school and special school (SLB) is more than 44.6 million children, and more than 5 million are in Central Java.[2] All of these students must do distance learning with online methods that make children do more activities in the house and look at the gadget screen. Children cannot meet with friends and do physical outdoor activities. Surely this implicates the lack of outdoor activities, intensity exposed to sunlight, and social activities.

Prolonged physical activity and inactivity are associated with negative physical and mental health outcomes, such as loss of muscle and cardiorespiratory fitness, weight gain, psychosocial problems, and even poor academic performance. During the pandemic, the prevalence of physically inactive students increased from 21.3% to 65.6%. Screen time considerably increases during the total pandemic (average + 1730 minutes, or about 30 hours per week). Evidence shows that physical activity provides protection from viral infections, especially among vulnerable populations.[3]

Studies show that in the short term exercise can help the immune system find and deal with pathogens; and in the long run, regular exercise slows changes that occur in the immune system as we age, thereby reducing the risk of infection.[4] Lack of physical activity outdoor is also related to lack of body exposure to sunlight. Sun exposure helps the body make vitamin D naturally. Vitamin D can boost the immune system and help fight diseases, including heart disease, muscle sclerosis, flu, autoimmune diseases, and certain cancers.[5]

Sedentary lifestyles tend to continue to expand in technologically advanced societies. Increased use of social media, has reduced the amount of time a teenager has to exercise. Based on a study of students of SMAN 6 Surabaya, the majority of respondents had relatively low exercise habits (52.6%) whereas, the intensity of using social media was high (57.1%). The high intensity of the use of social media is related to low exercise habits.[6]

Therefore, governments, schools, health professionals, and parents need to be aware of severe situations and implement more effective physical activity interventions to minimize the negative impact of the COVID-19 pandemic on the health of children and adolescents.[3]

2 Material and Method

This is a quantitative descriptive study with a cross-sectional approach. The study population was all school children in the province of Central Java as many as 5,141,607 people (data for 2019). The sample size is 167 people with inclusion criteria, namely children who live in Central Java province, aged 10-19 years, and are still in school or student status (elementary, junior high, and high school). The number of samples is determined based on the answers to the online questionnaire sent back. Determination of a minimum age of 10 years with consideration of the ability to answer and understand all research questions. Exclusion criteria are respondents whose answers to the questionnaire are incomplete and / or unclear so they cannot be analyzed, and respondents who do not meet the inclusion criteria.

Collecting data with closed questionnaire instruments using Google-form due to the COVID-19 pandemic situation and social & physical distancing policies that require staying at home so that face-to-face interviews are not possible. Data were collected in the early May 2020 period by distributing questionnaires to school children for 2 weeks. A total of 189 questionnaires were returned and after cleaning the data, 167 relevant data were obtained and followed up.

The independent variables of the study include characteristics (age, sex, education, and family status), knowledge, attitudes, perception of social distancing policy, perception of social impact, family support, perception of mental vulnerability, communication, comfort, and physical health status. The dependent variable is compliance in carrying out physical activities as measured by indicators of sports activities and sunbathing in the morning. Data were analyzed univariately with frequency distribution and bivariate analysis with crosstables and rank-spearman correlation tests because the data were not normally distributed.

3 Result and Discussion

Table 1. shows that the majority of school children who were respondents included the early adolescent group (ages 11-15 years). The average age is 14.82 years (SD 2.03) with the youngest age is 11 years and the oldest is 19 years. Most respondents were female and attended secondary school (SLTP and SLTA) with family status was not a JKN-KIS recipients. Most respondents have a good category for all variables even though the amount of proportion varies between variables. They also tend to be obedient to carry out physical activities routinely at 61.7%. Walking activities around residential areas and neighborhoods, cycling, helping to wash vehicles, and cleaning the house is a form of physical activity that is often done by school children during quarantine due to the COVID-19 pandemic. In addition, they also try to sunbathe every morning for 10-15 minutes according to the advice of health workers and the information they receive from the mass media and social media they have. Table 1 also shows that although the proportion of respondents in the good category is higher for all variables in this study, some variables show very small differences in the proportion of differences, namely the variable perception of mental vulnerability, perception of social impact and family support.

Table 1. Characteristic of students who were the sample of the study

NO	VARIABLE	CATEGORIES	N	%
1	Age	a. Early teenager (11-15 y.o.)	104	62.3
		b. Older teenager (16-19 y.o.)	63	37.7
2	Sex	a. Male	60	35.9
		b. Female	107	64.1
3	Education	a. Elementary School	36	21.6
		b. Middle School	53	31.7
		c. High School	78	46.7
4	Family Status	a. JKN/KIS recipients	23	13.8
		b. Not a JKN/KIS recipients	144	86.2
5	Knowledge	a. Low	63	37.7
		b. Good	104	62.3
6	Attitude	a. Low	55	32.9
		b. Good	112	67.1
7	Perception to the issue of Social & Physical Distancing	a. Low	74	44.3
		b. Good	93	55.7
8	Perception to the social implication	a. Great	79	47.3
		b. Low	88	52.7
9	Family support	a. Low	78	46.7
		b. Good	89	53.3
10	Perception to the mental vulnerability	a. Great	83	49.7
		b. Low	84	50.3
11	Communication	a. Low	72	43.1
		b. Good	95	56.9
12	Comfort	a. Low	74	44.3
		b. Good	93	55.7
13	Physically health-status	a. Low	43	25.7
		b. Good	124	74.3
14	Compliance with physical activity	a. Low	64	38.3
		b. Good	103	61.7

The low difference between the proportion of children with a perception of great mental vulnerability with a low indicates that the COVID pandemic raises two different dimensions of understanding. There are some children who feel depressed, confused, and stressed, but on the other hand, there are also children who feel happy because they can play freely and are not bound to go to school. The same relative condition also occurs in the perception variable of social impacts felt during the COVID-19 pandemic.

Regular physical activity (such as walking, running, and exercising) increases the cardiovascular functional ability and is beneficial in reducing the risk of chronic diseases such as obesity, heart disease, stroke, type 2 diabetes mellitus, over nutrition and depression. Therefore, physical activity must be carried out routinely and structured. Other benefits of physical activity include increasing endurance, strengthening muscles and bones, maintaining ideal body weight, and increasing fitness.[7]

On the other hand, physical activity can also reduce mental depression (stress), increase self-confidence and a sense of responsibility, and help maintain optimal health.

Several studies prove that the current COVID-19 pandemic situation is causing anxiety in families and communities, including children as family members.[8] Anxiety is mainly related to fear and risk of contracting the disease, and uncertainty when this situation ends. Prolonged anxiety can cause mental depression such as sleep disturbance, fear of interacting with others, abuse of illegal drugs, and a decrease in the immune system which makes children more vulnerable to certain diseases. Komalasarri's research in Padang also proved that anxiety is related to depression experienced by students.[9]

Table 2. Cross-Tabulation Relationship of the Independent to the Research Variables

No	Independent Variable	Compliance In Physical Activity				P
		Low		Good		
		N	%	N	%	
1	Age					
	a. Early teenagers (11-15 y.o.)	37	35.6	67	64.4	0.471
	b. Older teenager (16-19 y.o.)	27	42.9	36	57.1	
2	Sex					
	a. Male	24	40.0	36	60.0	0.712
	b. Female	40	37.4	67	62.6	
3	Education					
	a. Elementary school	10	27.8	26	72.2	
	b. Middle school	19	35.8	34	64.2	
	c. High school	35	44.9	43	55.1	
4	Family status					
	a. JKN/KIS recipient	8	34.8	15	65.2	0.964
	b. Not a JKN/KIS recipient	56	38.9	88	61.1	
5	Knowledge					
	a. Low	24	38.1	39	61.9	0.517
	b. Good	40	38.5	64	61.5	
6	Attitude					
	a. Low	21	38.2	34	61.8	0.068
	b. Good	43	38.4	69	61.6	
7	Perception to the issue of Social & Physical Distancing					
	a. Low	27	36.9	47	63.5	0.778
	b. Good	37	39.8	56	60.2	
8	Perception to the social implication					
	a. Great	33	41.8	46	58.2	0.376
	b. Low	31	35.2	57	64.8	
9	Family support					
	a. Low	36	46.2	42	53.8	0.001*
	b. Good	28	31.5	61	68.5	
10	Perception to the mental vulnerability					
	a. Great	33	39.9	50	60.2	0.155
	b. Low	31	36.9	53	63.1	

11	Communication					
	a. Low	37	51.4	35	48.6	0.005*
	b. Good	27	28.4	68	71.6	
12	Comfort					
	a. Low	34	45.9	40	54.1	0.011*
	b. Good	30	32.3	63	67.7	
13	Physically health status					
	a. Low	21	48.8	22	51.2	0.038*
	b. Good	43	34.7	81	65.3	

*Significant in $p < 0.05$ with Rank-Spearman test

The correlation test indicates that partially, the variables of family support, ongoing communication, amenities, and physical health status show a significant correlation with school children's adherence to physical activities because the p-value obtained from the statistical test is less than 0.05 ($p < 0.05$). The direction of the relationship is also positive. While the variable characteristics, knowledge, attitudes, policy perceptions, perceptions of social impact, and perceptions of mental vulnerability are not statistically related. These results also indicate that family support and ongoing communication interactions have a very close relationship (see Table 2).

Family support has been shown to be related to adherence to children in carrying out various exercises and other physical activities. Conceptually, family support can be divided into 4 dimensions, namely instrumental support, informational support, appreciation support, and emotional support.[10],[11] Social support in the form of facilitation of needs and facilities in various activities carried out by family members, informational support in the form of advice and clear explanations. Appreciation support can take the form of assessments of achievements and positive performance achievements generated as feedback, while emotional support can be in the form of feelings of sympathy, empathy, and care for the problems faced by family members.

Social support provided by the family plays an important role in the physical, mental, and emotional development of children because of interpersonal relationships and interactions between family members that create very strong emotional bonds. Relationships between family members and emotional life influence each other in the family.[12] The role of the family, especially parents, gives children the first experience and social adaptation in each of their behavioral practices, including the practice of maintaining physical health and fitness through sports and various other physical activities. The form of social support provided refers to the four dimensions, such as providing information, advice, direction, exchanging opinions when children are facing problems, the provision of sports equipment and facilities needed, involved in jointly doing sports, as well as providing time to listen to all his complaints. Other support can also be in the form of incentives and disincentives such as gifts for doing positive things and fines or penalties for doing negative things.

Family as the smallest element of society occupies the main position which is fundamental in influencing the life of a child, especially in critical times. In essence, the family is a container for the formation of the character, attitudes, and behavior, including in the behavior of maintaining physical and mental health status. These results are in line with research in Malang which proves that there is a positive relationship between family social support and the career maturity of junior high school students.[11] Larasati et al's research also indicate that family support contrib-

utes to the development of children's psychology. Family support not only provides support for children but also other groups, such as the elderly group, as Atmaja & Rahmatika's research proves that family social support influences the motivation of the elderly group to maintain their health through physical activity.[13] Morrissey et al's study in the USA proves that family support and friend support are predictors of the increased activity and intensity of adolescents doing exercise.[14] Studies in China also show that parental support for sports and physical activity is very important in promoting and facilitating the participation of school children in moderate-to-vigorous physical activity (MVPA).[15]

The COVID-19 pandemic situation, directly and indirectly, contributes to the health status of children, including school-age children. Although the risk of exposure to COVID-19 is lower in children, confusion over the situation and unclear family destinies have a major impact on children. The negative effects of school closure and the necessity of online learning models have the potential to make children anxious, stressed, depressed, and feel isolated from their environment. Changes in learning patterns from originally face-to-face directly to online-based trigger emotional vulnerability and discomfort. Hence, the role and support of parents, as well as other family members during the COVID-19 pandemic quarantine becomes the most important thing for children.[16]

For further information, communication interactions that are established between school children and family members, with friends, class teachers, and everyone in their environment contribute to the participation and compliance of various healthy physical activities. Communication interaction refers to the mechanism of delivering messages that can influence decision making. Communication also includes information dissemination activities that can increase awareness, change attitudes and behavior, and motivate healthy behavior.[17] Poor communication results in misperceptions, misinterpretations, and conflicts that result in poor compliance, including compliance with various physical activities by school children in a COVID-19 pandemic situation. Children will tend to remain in the room while sleeping, eating, watching TV, or playing gadgets which incidentally is a very small mechanism of motion.

School-age children need a lot of information in shaping the character of their soul. They tend to be easily influenced by something that is considered new and good, although not healthy. Therefore, groups of teenagers and school children are often easy targets for advertisements that tend to neglect health. Although lots of other communication strategies, the best communication strategy from parents and families towards children is exemplary. Being a role model, parents should give real examples of proper health behavior, one of which is carrying out physical activities to maintain fitness and endurance.[12]

Communications related to the patterns of relationships with others that include the process of interaction and its meaning. A person's character will be formed from ongoing interpersonal communication interactions. The purpose of interpersonal communication carried out in the family is to strengthen social relations between individuals in the family (family members), as well as a function of socialization in instilling values and norms that must be obeyed. The communication model can be in the form of verbal and non-verbal. Verbal communication forms are seen based on the use of language, intonation, tone, and volume during speech or dialect and dialect,

while non-verbal communication can be done through facial expressions, eye gaze, gestures, and appearance. Non-verbal communication models further strengthen verbal communication.[18] Prabandari & Rahmiaji explained further that the habit of using mobile phones as a technology-based communication medium that is not well controlled by parents can reduce opportunities for direct communication between children and parents at home. The existence of this technology is a factor reducing the portion of direct communication that exists and can reduce the quality of communication (response, openness) of children to parents. The effectiveness of family communication is determined by the attitude of parents towards the use of smartphones.[19]

School-age children is a period where they seek and develop their personal identity. The process of finding identity is largely determined by the information it receives from various sources and media, especially from family at home, friends, and teachers at school and from the community in the surrounding environment. Immature psychological and mental development in adolescents has an impact on the inability to filter out all information received. Advances in web-based technology and the internet in social media provide unlimited space in the interaction of information and communication that can have negative implications for behavior. The rapid development of information technology makes mass media a necessity and an important part of modern life. The mass media is able to provide information and knowledge that shape perception. The research of Sriyanto et al proved that the mass media influences assertive behavior and juvenile delinquency tendencies. This result is also in line with McQuail's opinion that the influence of the mass media is very strong in shaping behavior.[12]

Other variables that also contribute to adherence to physical activity in school children are perceived dimensions of comfort and physical health status. The higher the comfort felt as the effect of various physical activities carried out will increase compliance to more routinely do it. If the physical health status of the children is in top condition, they tend to increase their willingness and motivation to exercise and sunbathe in the morning, as suggested by health workers. These results are in line with the research of Alamsyah et al. Which proves that there is a positive correlation between physical fitness and physical activities undertaken by students of SMK 11 Semarang City.[20] Romansyah et al's research also shows a relationship between perceived body image disturbance and sports activities undertaken.[21]

4 Conclusion and Suggestion

This study indicates that family support, ongoing communication, comfort, and physical health status show a significant correlation with schoolchildren's compliance with physical activities. Family support has been shown to be related to child compliance — namely instrumental support, informational support, appreciation support and emotional support. The best communication strategy from parents for children is exemplary in doing exercises and many healthy activity. Support and involvement of family members to jointly carry out physical activities on a regular basis could be done through intensive communication with parents to always invite and

remind them. Health workers could monitor and evaluate it by involving the role of school teachers.

References

- [1] Gugus Tugas Percepatan Penanganan Covid-19. Data COVID-19 Berdasarkan Kelompok Umur [Internet]. 2020. Available from: www.covid19.go.id
- [2] Kementerian Pendidikan dan Kebudayaan. Data Peserta Didik [Internet]. 2019 [cited 2020 Jul 1]. Available from: www.dapo.dikdasmen.kemdikbud.go.id/pd
- [3] Mi X, Zhang ZZ, Kuwahara K. Impact of COVID-19 pandemic on children and adolescents' lifestyle behavior larger than expected. *Elsevier Public Heal Emerg Collect*. 2020;PMC7190470.
- [4] Simpson RJ, Campbell JP, Gleeson M, Krüger K, Nieman DC, Pyne DB, et al. Can exercise affect immune function to increase susceptibility to infection? *Exerc Immunol Rev*. 2020;26(January):8–22.
- [5] Gallagher G. Is Sunbathing Good for You? Benefits, Side Effects, and Precautions. [Internet]. 2019 [cited 2020 Jul 1]. Available from: <https://www.healthline.com/health/sunbathing>
- [6] Setiawati FS, Mahmudiono T, Ramadhani N, Hidayati KF. Intensitas Penggunaan Media Sosial, Kebiasaan Olahraga, dan Obesitas Pada Remaja Di SMA Negeri 6 Surabaya Tahun 2019 Intensity of Social Media Usage, Exercise Habits, and Obesity among Adolescent in Senior High School 6 Surabaya 2019. *Amerta Nutr*. 2019;142–8.
- [7] Nieman DC, Wentz LM. The compelling link between physical activity and the body's defense system. *J Sport Heal Sci*. 2019;8(3):201–17.
- [8] Nurkholis. Dampak Pandemi Novel-Corona Virus Disease (Covid-19) terhadap Psikologi dan Pendidikan serta Kebijakan Pemerintah. *J PGSD*. 2020;6(1):39–49.
- [9] Komalasari W. Hubungan Kecemasan Orang Tua dengan Depresi pada Anak Sekolah Dasar di SDN 03 Simpang Haru Padang. *Menara Ilmu*. 2019;XIII(2):136–40.
- [10] Larasati T, Mubin MF, Targunawan T. Dukungan Keluarga terhadap Perkembangan Psikologi: Konsep Diri Anak Usia Sekolah Dasar Di Wilayah Banjir ROB Kelurahan Bandharharjo Semarang Utara. *J Ilmu Keperawatan dan Kebidanan*. 2015;3:1–9.
- [11] Rahma U, Rahayu E. Peran Dukungan Sosial Keluarga dalam Membentuk Kematangan Karier Siswa SMP. *J Ilmu Kel dan Konsum*. 2018;11(3):194–205.
- [12] Sriyanto S, Abdulkarim A, Zainul A, Maryani E. Perilaku Asertif dan Kecenderungan Kenakalan Remaja Berdasarkan Pola Asuh dan Peran Media Massa. *J Psikol*. 2014;41(1):74.
- [13] Atmaja RAJ, Rahmatika R. Peran Dukungan Sosial Keluarga terhadap Motivasi Menjaga Kesehatan melalui Aktifitas Fisik pada Lansia. *J Psikogenes*. 2017;5(2):180–7.

- [14] Morrissey JL, Janz KF, Letuchy EM, Francis SL, Levy SM. The effect of family and friend support on physical activity through adolescence: A longitudinal study. *Int J Behav Nutr Phys Act.* 2015;12(1):1–9.
- [15] Liu Y, Zhang Y, Chen S, Zhang J, Guo Z, Chen P. Associations between parental support for physical activity and moderate-to-vigorous physical activity among Chinese school children: A cross-sectional study. *J Sport Heal Sci.* 2017;6(4):410–5.
- [16] Pradana AA, Casman C, Nur'aini N. Pengaruh Kebijakan Social Distancing pada Wabah COVID-19 terhadap Kelompok Rentan di Indonesia. *J Kebijak Kesehat Indones.* 2020;9(2):61–7.
- [17] Rahmadiana M. Komunikasi Kesehatan : Sebuah Tinjauan*. *J Psikogenes.* 2012;1(1):88–94.
- [18] Sari A, Hubeis A, Mangkuprawira S, Saleh A. Pengaruh Pola Komunikasi Keluarga Dalam Fungsi Sosialisasi Keluarga Terhadap Perkembangan Anak. *J Komun Pembang.* 2010;8(2):36–45.
- [19] Prabandari AI, Rahmiaji LR. Komunikasi Keluarga dan Penggunaan Smartphone oleh Anak. *Interak Online.* 2019;7(3):224–37.
- [20] Alamsyah DAN, Hestiningsih R, Saraswati LD. Faktor-Faktor Yang Berhubungan Dengan Kebugaran Jasmani Pada Remaja Siswa Kelas Xi Smk Negeri 11 Semarang. *J Kesehat Masy.* 2017;5(3):77–86.
- [21] Romansyah M, Natalia D. Gangguan Body Image dihubungkan dengan Aktivitas Olahraga pada Mahasiswa Obesitas. *J STIKES.* 2012;5(1):1–10.

Blended Learning as The New Innovation in Physical Education Class

Tandiyo Rahayu¹, Mohammad Arif Ali², Katrin Koenen³, Andrea Blume⁴,
Gustiana Mega Anggita⁵, Billy Castyana⁶, Hermawan Pamot Raharjo⁷

{tandiyorahayu@mail.unnes.ac.id¹, hiarifalikhan@mail.unnes.ac.id², kkoenen@icsspe.org³}

Universitas Negeri Semarang, Semarang, Indonesia¹²
Senate Department for the Interior and Sport, Berlin, Germany³

Abstract. Blended learning is a combined teaching method between conventional and modern technology-based. This study aim to investigate how is the response of students and teachers to the use of blended learning in physical education class. Three different blended learning designs in order to see which the best design for what physical education material, then each design was applied in lesson plans. Total participant in this study is 681 people. In-depth interview to physical education teachers and high school students in Semarang city was performed to collect the data. Regardless the design of blended learning, it takes together blended learning is applicable for physical education learning process as seen in the data that 89% of participant had agree and only 11% disagree. Blended learning has accepted very well both by students and PE teachers. Blended learning is acceptable in order to improve the quality of physical education learning process.

Keywords: blended learning; physical education; new normal.

1 Introduction

Technology development, which has continued to develop in recent years, requires all parties to always update knowledge in any areas, including teaching methods in schools. This update aims to make students benefit maximally from the lessons provided, and to improve the quality of learning as a whole [1], because the scope of learning is unlimited so that students can learn anywhere [2].

Based on these facts, the combination learning model, which is currently known as blended learning, is considered suitable for improving the quality of learning. Therefore, this study aim to investigate how is the response of students and teachers to the use of blended learning in physical education class.

2 Materials and Methods

Design of Physical Education Lesson Plans, we have developed three different blended learning designs in order to see which the best design for what physical education material, then each design was applied in lesson plans. Blended learning **design number one** is by combining instructional modalities (teacher demonstration with or without another instructor) and delivery media (video analysis, gaming and simulation, volunteer. Such as FF SetUp 270; Ncesoft Flip Bookmarker 2.8.1; QuizCreator; Screencast O Matic, etc.). Blended learning **design number two** is by combining instructional methods (recitation or drills and student report such as film or writing can be individual or group). Blended learning **design number three** is by combining online sources (google, youtube, etc.) and face to face instructions (usage of pre-test and post-test, case studies or problem solving, student oral report can be individual or group). More detail information about blended learning designs, see Table 1. below.

Table 1. Blended learning designs

Blended Learning Design Number ONE Combining Instructional Modalities or Delivery Media	
Instructional Modalities	Delivery Media
Teacher Demonstration with or without another instructor	Video Analysis, Gaming and Simulation, Volunteer. Example: FF Set-Up 270; Ncesoft Flip Bookmarker 2.8.1; Quiz-Creator; Screencast O Matic, etc.
Blended Learning Design Number TWO Combining Instructional Methods	
Instructional Methods #01	Instructional Methods #02
Recitation or Drills	Student Written Report (individual or group)
Blended Learning Design Number THREE Combining Online and Face to Face Instructions	
Online	Face to Face Instructions
Online Sources like Google, YouTube, etc.	Usage of Pre-Test and Post-Test, Case Studies or Problem Solving, Student Oral Report (individual or group)

Participants, total participant in this study is 681 people (male students = 283, female students = 398), they came from 9 different schools in Semarang Central Java, with variety ages: 14 years old = 1 participant, 15 years old = 70 participants, 16 years old = 411 participants, 17 years old = 188 participants, 18 years old = 8 participants, and >18 years old = 3 participants.

Data collection, in-depth interview to physical education teachers and high school students in Semarang city was performed to collect the data. Addressed

questions was related to determine the level of IT literacy, their expectations for physical education learning, the availability of facilities in schools.

Data analysis, to find the meaning in data which leads to derived knowledge, whereas eventually, data become useful information to make a decision is the main purpose of data analysis. In order to describe basic features (information) of the data in this study, and to emphasize the dominant variables, percentage analysis was used to interpret our primary data, then it is presented in graphical form, [3].

3 Result and Discussion

Blended learning is a combined teaching method between conventional and modern technology-based. Blended learning has many advantages, including flexibility in terms of distance to learn and can provide opportunities for students to interact with teachers and other students [4]. In fact, it is able to provide the same learning outcomes even beyond traditional teaching [5], [6], (Fig. 1.). Regardless the design of blended learning, it takes together blended learning is applicable for physical education learning process as seen in the data that 89% of participant had agree and only 11% disagree, (Fig. 2.).

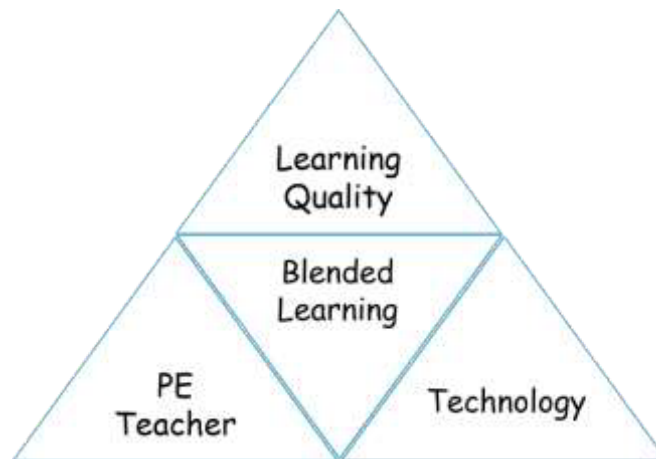

Fig. 1. Concept design of blended learning

Benefits of blended learning are: 1) Besides it offers a public forum, the online resources are always there to help. 2) Every individual receives personalized teaching materials according to their learning needs. 3) Providing good environmental collaborative for participants. 4) It offers better evaluation option of online assessment. 5) It is not only effective in the teaching duration but also reduces travel costs. Meanwhile, shortages of blended learning are the cost of infrastructure and devices, and depending on technology feasibility [7], [8].

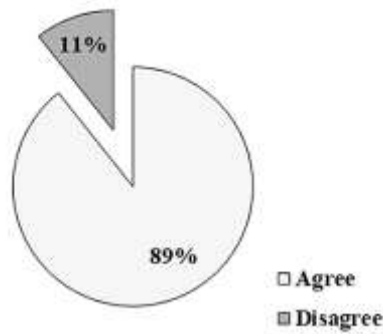

Fig. 2. Blended learning is applicable for physical education

How is the response of students and teachers to the use of blended learning in physical education class is answered by four indicators (Ease of using media; Ease of accessing media; Ease of operating media; User satisfaction) we have determined in this research. Blended learning has accepted very well both by students and PE teachers, as it showed in the data (Fig. 3.) 93% of responses agree with the use of this new approach, and only 7% disagree. Surprisingly, BLD-01 continuously seems the better, more acceptable (agree: 33% disagree: 2%) followed by BLD-03 (agree: 30% disagree: 2%), and BLD-02 (agree: 30% disagree: 3%).

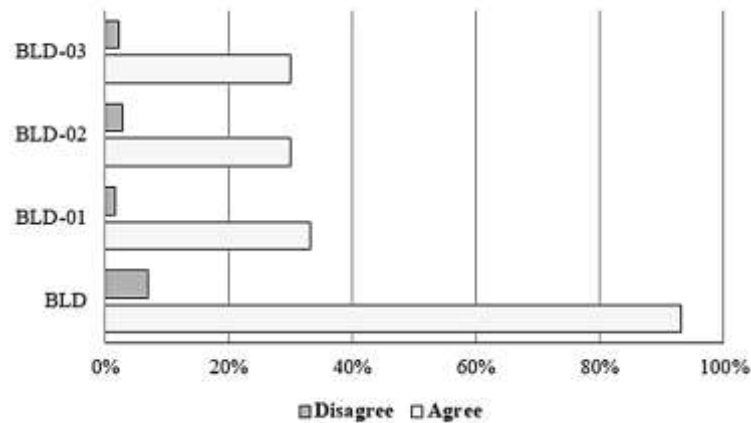

Fig. 3. The response of students and teachers about blended learning for PE

Through blended learning methods students are able to increase their social sense towards peers through this learning method compared to traditional learning and full online learning [9]. This indicates that blended learning is able to combine traditional and online learning well [10] and can be classified as educational innovation [11]. Moreover, blended learning also affecting students's satisfaction positively as well as

the tutor's role in problem-based learning [12]. Once students are exposed to tools that encourage their related knowledge on various capabilities, blended learning is able to improve student's productivity. Blended learning allowed educators to be able identify strengths and weakness of their students [13]

Another form of blended learning called Flipped Learning (FL) instruct students individually or in a group to watch online lectures prior to class, then interacting with peers and instructors where this engagement is happening in classroom learning activities [14]. A study conducted by Dankbaar, M. E. W. et al. in 2014, comparing a traditional teaching method and blended learning in training students showing that there was not different in learning results, students' perspective was positive. However, blended learning students showing more confident regarding achievement in learning objectives[15]. Blended learning methods as manifestation of human-to-machine interaction showing capabilities to enhance learning processes [16]. Furthermore, although it is as modern evolution instructional technologies, blended learning still involving some aspects of human thought processes, [17]. Blended learning offers an effective and attractive teaching solution, leading to a significant reduction in costs.

4 Conclusion

This study found that blended learning is acceptable in order to improve the quality of physical education learning process in Central Java, Indonesia. This study provides three different designs of blended learning references to modify lesson plans of physical education class according to their (students and teachers) needs.

Acknowledgments

A research and developments approach for improving physical education teacher professionalism. Focus on blended learning to enhance the learning of physical education in Central Java Province – Indonesia. *This study was granted by International Council of Sport Science and Physical Education (Biennial Working Programme Grant 2019/2020).*

References

- [1] C. Williams, "Learning On-line: A review of recent literature in a rapidly expanding field," *J. Furth. High. Educ.*, vol. 26, no. 3, pp. 263–272, Aug. 2002, doi: 10.1080/03098770220149620.
- [2] A. R. Sari, "Strategi blended learning untuk peningkatan kemandirian belajar dan kemampuan critical thinking mahasiswa di era digital," *J. Pendidik. Akunt. Indones.*, vol. 11, no. 2, Dec. 2013, doi: 10.21831/jpai.v11i2.1689.
- [3] J. Lutabingwa and C. J. Auriacombe, "Data Analysis in Quantitative Research," *J. Public Adm.*, vol. 42, no. 528–548, 2007.
- [4] N. Vernadakis, M. Giannousi, V. Derri, M. Michalopoulos, and E. Kioumourtoglou, "The impact of blended and traditional instruction in

- students' performance," *Procedia Technol.*, vol. 1, pp. 439–443, 2012, doi: 10.1016/j.protcy.2012.02.098.
- [5] C. Chen and K. Jones, "Blended learning vs. traditional classroom settings: Assessing effectiveness and student perceptions in an MBA accounting course," *J. Educ. Online*, vol. 4, no. 1, pp. 1–15, Jul. 2007, doi: 10.9743/JEO.2007.1.3.
- [6] B. F. Melton, H. Bland, and J. Chopak-Foss, "Achievement and Satisfaction in Blended Learning versus Traditional General Health Course Designs," *Int. J. Scholarsh. Teach. Learn.*, vol. 3, no. 1, Jan. 2009, doi: 10.20429/ijstl.2009.030126.
- [7] D. Muravlov, "Advantages and Disadvantages of Blended Learning," *Raccoon Gang*, 2018. [Online]. Available: <https://raccoongang.com/blog/advantages-and-disadvantages-blended-learning/>. [Accessed: 01-Jul-2020].
- [8] S. Chen and Y. Lu, "The Negative Effects and Control of Blended Learning in University," in *Proceedings of the 2013 the International Conference on Education Technology and Information Systems*, 2013, doi: 10.2991/icetis-13.2013.7.
- [9] A. P. Rovai and H. Jordan, "Blended learning and sense of community: a comparative analysis with traditional and fully online graduate courses," *Int. Rev. Res. Open Distrib. Learn.*, vol. 5, no. 2, Aug. 2004, doi: 10.19173/irrodl.v5i2.192.
- [10] I. E. Allen, J. Seaman, and R. Garrett, *Blending in: The extent and promise of blended education in the United States*. 2007.
- [11] D. R. Garrison and N. D. Vaughan, *Blended Learning in Higher Education*. San Francisco, CA, USA: Jossey-Bass, 2007.
- [12] V. Woltering, A. Herrler, K. Spitzer, and C. Spreckelsen, "Blended learning positively affects students' satisfaction and the role of the tutor in the problem-based learning process: results of a mixed-method evaluation," *Adv. Heal. Sci. Educ.*, vol. 14, no. 5, pp. 725–738, Dec. 2009, doi: 10.1007/s10459-009-9154-6.
- [13] T. I. Oweis, "Effects of Using a Blended Learning Method on Students' Achievement and Motivation to Learn English in Jordan: A Pilot Case Study," *Educ. Res. Int.*, vol. 2018, pp. 1–7, Nov. 2018, doi: 10.1155/2018/7425924.
- [14] J. Lee, C. Lim, and H. Kim, "Development of an instructional design model for flipped learning in higher education," *Educ. Technol. Res. Dev.*, vol. 65, no. 2, pp. 427–453, Apr. 2017, doi: 10.1007/s11423-016-9502-1.
- [15] M. E. W. Dankbaar, D. J. Storm, I. C. Teeuwen, and S. C. E. Schuit, "A blended design in acute care training: similar learning results, less training costs compared with a traditional format," *Perspect. Med. Educ.*, vol. 3, no. 4, pp. 289–299, Sep. 2014, doi: 10.1007/s40037-014-0109-0.
- [16] R. Castro, "Blended learning in higher education: Trends and capabilities," *Educ. Inf. Technol.*, vol. 24, no. 4, pp. 2523–2546, Jul. 2019, doi: 10.1007/s10639-019-09886-3.
- [17] C. Dziuban, C. R. Graham, P. D. Moskal, A. Norberg, and N. Sicilia, "Blended learning: the new normal and emerging technologies," *Int. J. Educ. Technol. High. Educ.*, vol. 15, no. 1, p. 3, Dec. 2018, doi: 10.1186/s41239-017-0087-5.

Digital Media Habits among Parent of Preschool Child Aged 2-6 Years in Semarang City, Indonesia

Tandiyo Rahayu¹, Widya Hary Cahyati², Lukman Fauzi³, Michael Yong Hwa Chia⁴,
Terence Buan Kiong Chua⁵, Hendri Hariyanto⁶, Anisa Wahyu Hardini⁷,
Farida Nurjanati Hardanis⁸

{tandiyorahayu@mail.unnes.ac.id¹, widyahary27@mail.unnes.ac.id²,
lukman.ikm@mail.unnes.ac.id³}

Universitas Negeri Semarang, Semarang, Indonesia^{1,2,3}

Abstract. Excessive daily use in digital media can increase screen addiction, obesity, sedentary behavior, metabolic disorders, poor sleep, and eyesight problems. The aim was to know digital media habits among parent of preschool child aged 2-6 years in Semarang City, Indonesia. It was a cross-sectional design. Collected data were analyzed with a descriptive approach. Most digital media at home were television (540) and mobile devices (e.g., smartphones, tablets) (537). Otherwise, video game devices (e.g., console and handheld gaming players, virtual reality headset) owned a few of them (50). Digital media use among parent of preschool child was more frequent on weekdays than weekends. The correlation of parents with digital media and interactions with children in the weekday was 49.91%, and at the weekend was 57.37%.

Keywords: digital media, habits, parent, preschool children.

1 Introduction

The utilization of digital technology is more associated with aggressive behavior, sleep problems, lack of physical activity, metabolic disorders, lack of attention, and obesity in preschool and school-age children [1]. The effect of the benefits of digital media must be greater than the impact of the harm caused to the holistic development of preschool children. Children tend to be passive when looking at a digital screen. Besides that, the use of digital media also contributed to increased physical activity and increased brain development [2]. Children's responses to supportive programming about increased physical activity are fun, designed for them, and encourage active participation after age 3 [3], [4]. Previous studies found that children who play video games actively can cause a mild to moderate increase in physical activity in a short period [5], [6].

Mobile device applications can be used to increase the physical activity of children outside their room, explore the world, and stimulate brain growth [7]. Quality content provided by children by parents can connect directly with off-screen experiences, increase physical activity, encourage active involvement with caregivers and

peers, and support creative and imaginative play according to their age [8], [9]. Research in 2010 states that spending time watching commercial TV is significantly related to BMI and not related to watching TV time in non-commercial education [10], [11].

A 2009 study where they measured body fat and physical activity in preschoolers was associated with higher TV viewing behavior and body fat and showed this relationship did not significantly change when various levels of physical activity were also involved [12]. The most commonly reported side effects are impaired metabolic function, cardiology, understanding of learning, neurocognitive development, listening, and eyesight [13]. The choice of commercial TV is supported by sedentary behavior, which also displays unhealthy food advertisements and helps encourage them to get used to snacking, which has an impact on excess food intake in children [14], [15].

In the last five years, few descriptive studies have been represented in several Asian countries, which state that the screen time experienced by children has a significant influence on mobile devices, televisions, laptops, and other forms of digital media before they are elementary school. Because much research is far behind understanding the use of digital media among preschoolers, more research is needed before this issue becomes focused and sharper. The purpose was to know digital media habits among parent of preschool child aged 2-6 years in Semarang City, Indonesia

2 Methods

This research was a cross-sectional design approach. The study collects data about digital media habits among parent of preschool child aged 2-6 years in Semarang City, Indonesia. The tool used in this study is SMALLQ™. Surveillance of digital-Media hAbits in earLy chiLdhood Questionnaire is an acronym for SMALLQ™ that is developed by the Singapore research team. This questionnaire is in the English language has been translated to Bahasa Indonesia under the procedures established by the World Health Organisation. This SMALLQ™ provides several questions regarding the demographic state of the participants (highest education attained) and their parents (such as age, quality, and duration of digital media use).

3 Result and Discussion

Characteristics of respondent among parent of preschool child aged 2-6 years in Semarang City, Indonesia can be seen based on age and education level. At age, the average age of parents of children was 33 years 6 months. Characteristics of education level of parents can be seen in the following figure.

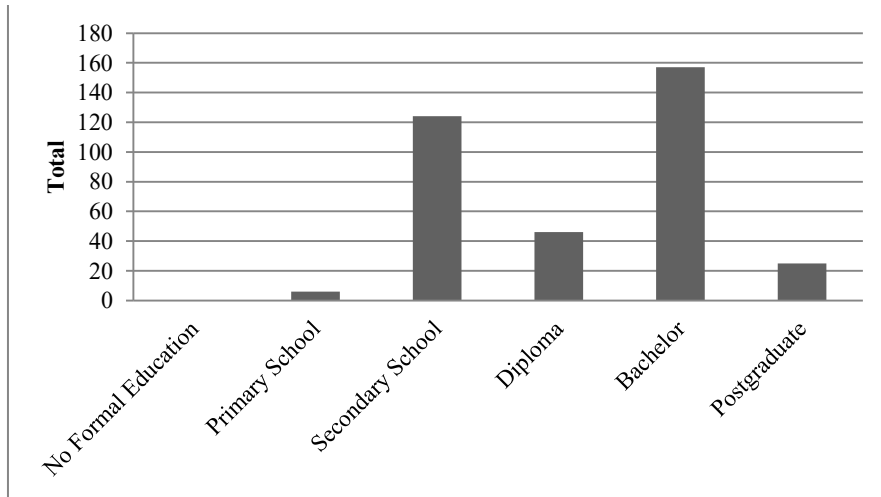

Fig. 1. Highest education attained of parent.

Based on the figure 1, it can be seen that there are no parents or guardians of children who do not have formal education, parents with an elementary school education were 6 people, middle school ie junior high school and high school as many as 124 people, diploma or academy and polytechnic education as many as 46, bachelor were 157 people, and there were 25 people who were Masters or Doctor.

At the figure 2, most digital media at home of parent were television (540) and mobile devices (e.g. smartphones, tablets) (537). Otherwise, video game devices (e.g. console and handheld gaming players, virtual reality headset) owned a few of them was (50). Data digital environment at home of parent can be seen in the figure 2.

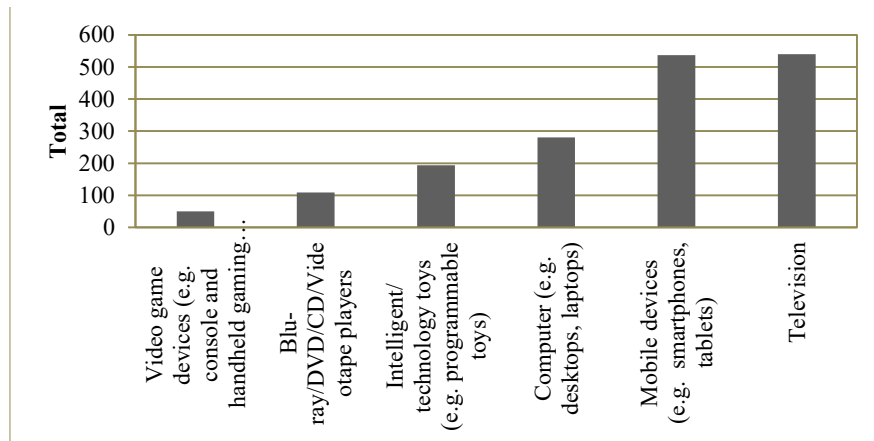

Fig. 2. Digital environment at home of parent

Digital media devices such as (fixed screens (computers, televisions, laptops) and cellular screens (tablets, mobile devices, smartphones)) aimed at adults are now easily available for preschoolers, with or without sufficient supervision by parents [16]. Based on the figure 2, digital media mostly used were television and mobile devices. The use of digital media can have positive and negative impacts as well as brain development, body metabolism, nutritional intake, sleep quality, physical activity, and social interaction for healthy growth [1].

A systematic review in 2012 of the effect of watching TV and its impact on food consumption in children aged 2 to 6 years, stated that most of them reported negative effects by only watching TV for 1 hour/day [17]. The average having sedentary behavior among child between preschool age (2-5 years) were between 7 and 7.5 hours every day [18]. Consumption for watching television is most commonly found in children, where boys need the most television watching and playing video games, while girls use computers more than watching television [18].

Applications that can increase physical activity outside the room and be used to exploring the outside world are mobile devices [7]. Quality digital media loaded with quality content can support more active and imaginative play, encourage the active involvement of children with peers and caregivers, can connect screen experiences, and can stimulate brain growth [8], [9]. The intensity of the use of gadgets was high in 20% of preschool children during the weekday while almost doubling (39%) during weekend [19]. The impact of electronic devices in children's bedrooms was often associated with less consumption of sleep minutes per night, partly due to the effect of the suppression of the hormone melatonin [20].

Table 2. The average time of parent's activity using digital media

No.	Activity	Average time in the weekdays	Average time in the weekend
1	Work	2 hours 24 minutes	53 minutes
2	Entertainment	1 hour 8 minutes	1 hour 24 minutes
3	Social Networking	1 hour 24 minutes	1 hour 24 minutes
4	Personal Development	1 hour 4 minutes	1 hour 2 minutes

The average time of parent's using digital media on weekday (Monday-Friday) was 1 hour 13 minutes, meanwhile on weekend (Saturday and Sunday) was 1 hour 11 minutes with the usage detail on the table above. Experts says that the maximum time for social media usage is 30 minutes in a day, thus can lead to significant improvement in well-being [21]. The results shows that parent's activity on social media is exceed from the time limit.

Parents sedentary behaviour associated with sedentary behaviour in children, weekends has stronger significant association observed than on weekdays. In the result, prents has higher amounts of screen time at weekdays than on weekend. Study shows that higher parent's screen time was associated to children screen time, and the BMI of parent's also associated to children BMI [22]. Intuitively, comparing on weekend than weedays, all members of families with preschool children spend more free time together and share more activities [23]. Intervention to decrease parents screen time was needed to reduce sedentary habit and to promoting healthy weight on family.

Based on the correlation of parents/guardians with digital media and interactions with children, on weekday (Monday-Friday) as many as 49.91% are used by parents/guardians to interact with children. As for the weekend (Saturday and Sunday) the average time parents/ guardians of children who are used to interact with children as much as 57.37%. This shows that parents/guardians of children interact a lot like interactions with children when playing digital media on weekends rather than on weekdays.

The relationship between parents and child in screen time was stronger at weekends compared weekdays. The self-efficacy of parents towards limiting screen time and relationships with children illustrates that screen time on weekdays and weekends has a significant inverse correlation [24]. In line with previous research, the result show about the relationship of parent and child in screen time stronger at weekends than on weekdays [25]. Habits related to energy balance such as sedentary behavior and physical activity in children allow a variety of influencing variables such as the different parents behavior on weekdays and weekends ie on weekends parents might be closer to their children and engage in various stimulating behavior on improving health activities such as applying parents rules to watch TV, screen time, and doing physical activities between parents and children [24].

4 Conclusion

Most digital media at home of parent were television and mobile devices (e.g. smartphones, tablets). Otherwise, video game devices (e.g. console and handheld gaming players, virtual reality headset) owned a few of them. The duration for parents' usage of digital media on weekday was more frequent than on weekend. The interactions of parents with children when playing digital media was stronger or much more on weekends than on weekdays.

Acknowledgments

We would like to thank the Faculty of Sports Science, Universitas Negeri Semarang, Indonesia for the funding.

References

- [1] R. Mustafaoğlu, E. Zirek, Z. Yasacı, and A. Razak Özdinçler, "The Negative Effects of Digital Technology Usage on Children's Development and Health," *Addicta Turkish J. Addict.*, vol. 5, no. 2, 2018.
- [2] M. Ponti *et al.*, "Le temps d'écran et les jeunes enfants: Promouvoir la santé et le développement dans un monde numérique," *Paediatr. Child Heal.*, vol. 22, no. 8, pp. 461–477, 2017.
- [3] A. R. Lauricella, E. Wartella, and V. J. Rideout, "Young children's screen time: The complex role of parent and child factors," *J. Appl. Dev. Psychol.*, vol. 36, pp. 11–17, 2015.

- [4] D. R. Anderson and K. G. Hanson, "From blooming, buzzing confusion to media literacy: The early development of television viewing," *Dev. Rev.*, vol. 30, no. 2, pp. 239–255, 2010.
- [5] L. M. Vanderloo, "Screen-viewing among preschoolers in childcare: A systematic review," *BMC Pediatr.*, vol. 14, no. 1, 2014.
- [6] J. Van 'T Riet, R. Crutzen, and A. S. Lu, "How Effective Are Active Videogames among the Young and the Old? Adding Meta-analyses to Two Recent Systematic Reviews," *Games Health J.*, vol. 3, no. 5, pp. 311–318, 2014.
- [7] J. Marsh *et al.*, "Exploring Play and Creativity in Pre- - Schoolers ' Use of Apps: A Report for Early Years Practitioners," *Technol. Play*, p. 203, 2015.
- [8] NAEYC, "Technology and Interactive Media as Tools in Early Childhood Programs Serving Children from Birth through Age 8," *Children*, no. January, pp. 1–15, 2012.
- [9] L. M. Takeuchi, "Families matter : Designing media for a digital age," no. June, p. 60, 2011.
- [10] F. J. Zimmerman and J. F. Bell, "Associations of television content type and obesity in children," *Am. J. Public Health*, vol. 100, no. 2, pp. 334–340, 2010.
- [11] N. Shenouda, "Swap Screen Time for Physical Activity," no. 5, pp. 11–12, 2012.
- [12] D. M. Jackson, K. Djafarian, J. Stewart, and J. R. Speakman, "Increased television viewing is associated with elevated body fatness but not with lower total energy expenditure in children," *Am. J. Clin. Nutr.*, vol. 89, no. 4, pp. 1031–1036, 2009.
- [13] E. Bozzola *et al.*, "Media devices in pre-school children: The recommendations of the Italian pediatric society," *Ital. J. Pediatr.*, vol. 44, no. 1, pp. 1–5, 2018.
- [14] V. C. Strasburger *et al.*, "Policy statement - Children, adolescents, obesity, and the media," *Pediatrics*, vol. 128, no. 1, pp. 201–208, 2011.
- [15] M. Hingle and D. Kunkel, "Childhood Obesity and the Media," *Pediatr. Clin. North Am.*, vol. 59, no. 3, pp. 677–692, 2012.
- [16] U. Nalika, "Mobile Device Usage Among Young Kids: A Southeast Asia Study," *Asianparent Insights Mob.*, no. November, pp. 1–61, 2014.
- [17] C. Ford, D. Ward, and M. White, "Television viewing associated with adverse dietary outcomes in children ages 2-6," *Obes. Rev.*, vol. 13, no. 12, pp. 1139–1147, 2012.
- [18] T. A. Barnett and A. S. Kelly, "Sedentary Behaviors in Today ' s Youth :," *AHA Sci. Statement*, pp. 142–159, 2018.
- [19] S. Asl and E. Manjuvani, "Usage of electronic gadgets among preschool children," *Int. J. Home Sci.*, vol. 5, no. 2, pp. 1–5, 2019.
- [20] D. Hill *et al.*, "Media and young minds," *Pediatrics*, vol. 138, no. 5, 2016.
- [21] M. G. Hunt, R. Marx, C. Lipson, and J. Young, "No more FOMO: Limiting social media decreases loneliness and depression," *J. Soc. Clin. Psychol.*, vol. 37, no. 10, pp. 751–768, 2018.
- [22] W. S. F. Goncalves, R. Byrne, M. T. Viana, and S. G. Trost, "Parental influences on screen time and weight status among preschool children from Brazil: A cross-sectional study," *Int. J. Behav. Nutr. Phys. Act.*, vol. 16, no. 1, pp. 1–8, 2019.

- [23] D. Sigmundová, E. Sigmund, P. Badura, J. Voká, L. Trhliková, and J. Bucksch, “Weekday-Weekend Patterns of Physical Activity and Screen Time in Parents and Their Pre-schoolers,” *BMC Public Health*, vol. 16, no. 898, pp. 1–9, 2016.
- [24] D. Sigmundová *et al.*, “Weekday – Weekend Variations in Mother-/Father – Child Physical Activity and Screen Time Relationship : A Cross-Sectional Study in A Random Sample of Czech Families with 5- to 12-year-old Children,” *Eur. J. Sport Sci.*, vol. 18, no. 8, pp. 1158–1167, 2018.
- [25] R. Jago *et al.*, “Cross-Sectional Associations between The Screen-Time of Parents and Young Children : Differences by Parent and Child Gender and Day of The Week,” *Int. J. Behav. Nutr. Phys. Act.*, vol. 11, no. 1, pp. 1–8, 2014.

The Effect of Cardio and Tabata Exercises on Decreasing Body Fat, Weight and Increasing Physical Fitness

Taufikkurrachman¹, Amy Nilam Wardathi², Afif Rusdiawan³, Reno Siska Sari⁴

{Ufikblack@gmail.com¹, Amynilamwardathi@budiutomomalang.ac.id²,
Rusdiawan.a@gmail.com³}

IKIP Budi Utomo, Malang, Indonesia^{1,2,3,4}

Abstract. The purpose of this study is to analyze the effects of cardio exercise and tabata method on body weight, body fat, and physical fitness. This study applied experimental design with pretest and posttest. A total of 27 respondents were all males and had BMI over 25.0 (overweight and obese). They were then divided into 3 groups: control (K1), cardio group (K2) and Tabata group (K3), each consisting of 9 individuals. K1 did not receive any intervention. While K2 and K3 were received six-weeks interventions, three times per week. K2 performed jogging and skipping training at 55% - 70% HRmax during 40-minutes. While K3 performed squat trust and skipping 8 sets at 90%-95% HRmax. There were significant differences between groups for all body composition measures. In conclusion, Tabata method represents an effective way in reducing body weight and body fat, but it is no better than cardio exercise in improving physical fitness.

Keywords: cardio; tabata; obesity; fat; body weight; fitness

1 Introduction

In Indonesia, the problem of overweight and obesity is a major health problem especially for students. The tendency for overweight and obesity in some people is closely related to diet, social status, and imbalance in body activity and food consumption. Obesity or over weight occurs when the body becomes fat (obese) due to the buildup of adipose, which is a special fat tissue that is stored excessively by the body. The amount of energy consumption from digested food exceeds the energy used for metabolism and physical activity [1]. Obesity is characterized by a body mass index (BMI) value above normal ($\geq 25 \text{ kg} / \text{m}^2$) between the 95th percentile on the growth curve, according to age and sex [2][3].

Cardio or often called aerobic exercise is the easiest and cheapest type of exercise that provides health for our bodies, especially for heart health and fitness[4]. There are several types of cardio exercises that we already know together such as running,

jogging, gymnastics, cycling and swimming [5]. The great benefits of cardio exercise to increase fat burning in the process of weight loss and to increase body fitness [6][7]. According to Andini (2016), the most effective type of exercise for weight loss is aerobic exercise with a long period of time between 20-60 minutes with an intensity of 65% -75% maximum heart rate [8].

Maybe we already know or hear that cardio training with low or moderate intensity in a long time (> 45 minutes) can burn body fat and improve fitness. This is true, but there are still other techniques that are more effective and efficient, do not require a long time but provide satisfying results. The technique is Tabata Training which is a training exercise introduced by Izumi Tabata in 1996 based on a 2: 1 ratio for training work time and rest time [9]

Through tabata training a trainer can improve one's physical condition and provide an evaluation (evaluation) of the shortcomings and progress of the training process. The advantages of tabata training include burning fat, increasing athlete's metabolism during and after training, effective and efficient in its implementation, improving anaerobic and aerobic systems and can be used for various activities [10]. The Tabata method is a method that utilizes the ratio between exercise and rest (pauses with high intensity). In practice, this training method lasts for 4 minutes with details of the time of sports activities within 20 seconds and 10 seconds (2: 1) for rest periods, and is repeated until those 4 minutes have expired [11].

Emphasized by other studies that Tabata training is another type of exercise that is considered to be able to contribute in increasing speed and VO₂max, Tabata training is a method that utilizes the ratio between exercise and rest (pauses with high intensity). In practice, this training method lasts for 4 minutes with the breakdown of the time of sports activities within 20 seconds and 10 seconds for rest periods, and is repeated until those 4 minutes have expired [12].

Tabata training is one of the HIIT (High Intensity Interval Training) training methods [9]. HIIT is a type of training with high intensity in each session, with speed or training load in a very short time [13]. HIIT exercises conducted with an intensity of 90-95% for 6 weeks can increase VO₂ max, decrease body fat percent and body mass index [14]. HIIT training is highly recommended for people with sedentary lifestyle, overweight, obesity and young adults [15]. Tabata exercises which include high intensity exercises can increase aerobic capacity, improve body composition, burn calories and fat, and increase excitatory threshold of lactic acid [11].

For the above description, the authors are interested in conducting research on the effect of cardio and tabata exercises on decreasing body fat, weight and increasing fitness.

2 Material and methods

Type of this research used experimental type. The research design used the pre-test-posttest group design.

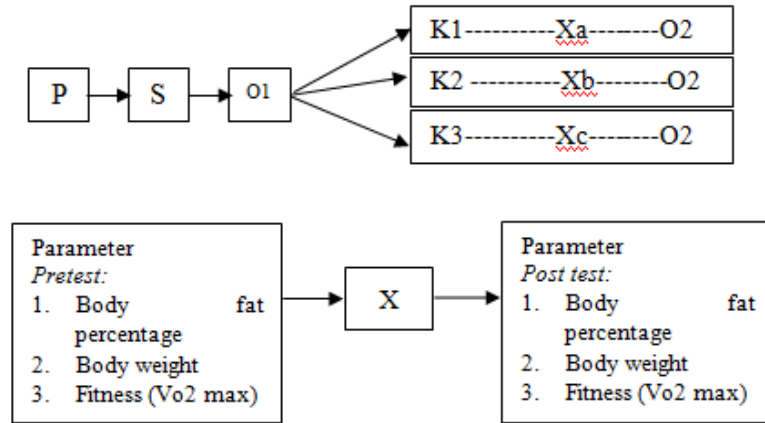

Fig. 1. Research design

Notes :

- P : Population
- S : Sample
- O1 : pre-test
- K1 : Group 1
- K2 : Group 2
- K3 : Group 3
- O2 : post test
- X : Treatment
- a : Cardio exercise
- b : Tabata exercise
- c : Control

The respondents of this research were students majoring in Health and Recreation Education Faculty of Physical Sciences and Sport Sciences IKIP Budi Utomo Malang with criteria for male sex, body weight between 55-70 kg, age between 18-22 years, having an overweight or obese body mass index (BMI), not under doctor's or postoperative care 6 months before the study, not having a serious muscle injury, no history of cardiovascular disease. They were then divided into 3 groups, the control group (K1), cardio exercise group (K2) and tabata exercise group (K3). By using federer formula $(t - 1) (r - 1) \geq 15$, a total of 27 respondents are obtained. Each consisting of 9 individuals per groups [16].

Data was collected by conducting 2 tests, namely pretest and post test. Pretest and posttest data collection was done by measuring body weight, fat percentage and physical fitness. Body weight was measured by weight scales. Percentage of fat measured is subcutaneous body fat in the triceps, biceps, subscapules and suprailiaca. Fat percentage was measured using a skinfold caliper. Then for physical fitness was

measured by conducting cooper running tests as far as 2.4 km and then the traveling time is calculated.

The treatment given to each group is different. The exercise treatment was given 18 times with the provisions 3 times a week for 6 weeks. For the control group (K1), only completed pretest and posttest and did not receive any intervention. For the cardio training group (K2), they were given a jogging exercise treatment for 8 meetings and skipping exercise for the next 8 meetings. Cardio exercise done for 40 minutes with moderate intensity (65% -75% DN max). For the tabata training group (K3), they were given squat trust and skipping exercise for 20 seconds of exercise and 10 seconds of rest for 8 sets. Exercises carried out for 20 minutes at intervals of 1 minute each set.

Data analysis in this research used descriptive test, normality test, manova test and LSD test with the help of SPSS 20 series.

3 Result

3.1 Descriptif statistic

Table 1. Deskriptif statistic (mean±SD) and homogeneity test of pretest dan posttest all variables

Variable	Mean ± SD body weight (kg)			p (sig)	
	Control	Cardio	Tabata		
Body Weight (Kg)	Pretest	79,78 ± 2,54	81,22 ± 5,49	79,33 ± 4,79	0,118
	Post test	79,67±2,92	78,33±2,91	74,78±5,07	0,299
	Δ Body weight (Post test – pretes)	-0,11±1,27	-2,89±1,61	-4,56±1,88	0,489
Percentage of Fat (%)	Pretest	84,78 ± 16,57	85,33 ± 8,34	85,00 ± 10,21	0,214
	Post test	85,00±17,89	80,22±9,71	77,33±9,79	0,347
	Δ Fat (Post test – pretes)	0,22±2,39	-5,11±2,32	-7,67±2,65	0,637
Physical fitness	Pretest	14,78 ± 1,11	14,26 ± 0,98	14,52 ± 0,93	0,520
	Post test	14,65±0,98	13,30±1,07	12,87±1,00	0,997
	Δ Physical fitness (Post test – pretes)	-0,13±0,46	-0,96±0,63	-1,65±0,77	0,620

p>0,05 shows homogeneous variable data

Homogeneity test of body weight both pre-test and post-test in all groups showed significant results. This is evidenced by the pre-test value (p = 0.118) and post test (p

= 0.299) and delta body weight ($p = 0.428$). So it can be concluded that all body weight data are homogene.

From the mean body weight pre-test measurements, the results in the control group were 79.78 ± 2.54 kg, the cardio group was 81.22 ± 5.49 kg and the tabata group was 79.33 ± 4.79 kg. Then after the treatment carried out a post test and obtained almost the same weight results in the control group by 79.67 ± 2.92 kg, decreased in the cardio group by 78.33 ± 2.91 kg and the tabata group by $74.78 \pm 5, 07$ kg. Descriptive test results are presented in the figure 2.

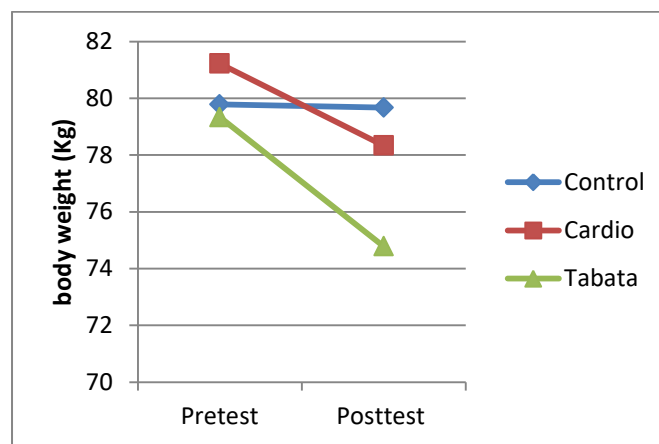

Fig. 2. Body weight diagram of control, cardio and tabata group

Fat homogeneity test both pre-test and post-test in all groups showed significant results. This is evidenced by the pre test values ($p = 0.214$) and post test ($p = 0.347$) and fat deltas ($p = 0.637$). So it can be concluded that all fat data are homogeneous.

From the average pre-test measurement of fat, the results obtained in the control group were 84.78 ± 16.57 , the cardio group was 85.33 ± 8.34 and the tabata group was 85.00 ± 10.21 . Then after the treatment was carried out post test and obtained almost the same fat results in the control group by 85.00 ± 17.89 , decreased in the cardio group by 80.22 ± 9.71 and the tabata group by 77.33 ± 9.79 . Descriptive test results are presented in Figure 3

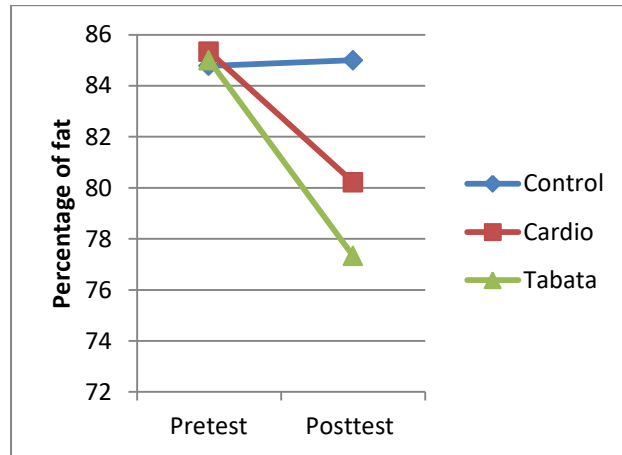

Fig. 3. Percentage of fat diagram of control, cardio and tabata group

Homogeneity test of physical fitness both pre-test and post-test in all groups showed significant results. This is evidenced by the pre test ($p = 0.520$) and post test ($p = 0.997$) and the fitness delta (0.620). So it can be concluded that all fat fitness data are homogeneous.

From the mean pre-test physical fitness measurement, the results obtained in the control group were 14.78 ± 1.11 , the cardio group was 14.78 ± 1.11 and the tabata group was 14.52 ± 0.93 . Then after the treatment was carried out post-test and obtained almost the same fitness results in the control group by 14.65 ± 0.98 , increased in the cardio group by 13.30 ± 1.07 and the tabata group by 12.87 ± 1.00 . Descriptive test results are presented in Figure 4

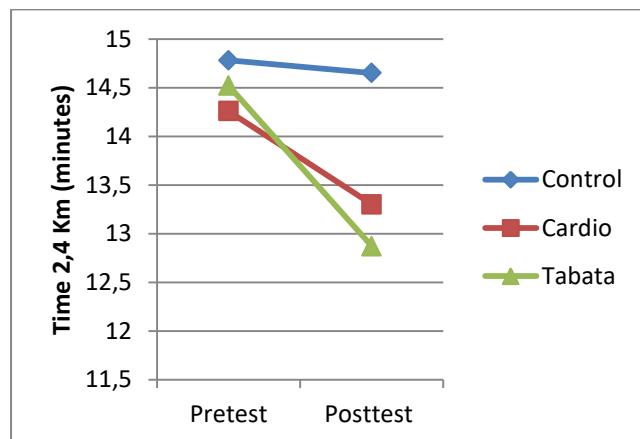

Fig. 4. Physical fitness diagram of control, cardio and tabata group

3.2 Normality Test

The next step is to test data normality using the Shapiro Wilk test.

Table 2. Result of Normality test

Variable		Group p (sig)		
		Control	Cardio	Tabata
Body weight	<i>Pre</i>	0,755	0,602	0,230
	<i>Post</i>	0,162	0,914	0,191
Percentage of fat	<i>Pre</i>	0,316	0,344	0,308
	<i>Post</i>	0,309	0,639	0,831
Physical fitness	<i>Pre</i>	0,458	0,161	0,911
	<i>Post</i>	0,615	0,186	0,849

$p > 0,05$ shows normal distribution data

From the results of normality test data on body weight, fat and fitness it was found that all data were normally distributed $p > 0.05$, both the control group, the fat group and the tabata group.

3.3 Manova Test

The result of the manova test can be seen in table 3.

Table 3. Test of Between-Subjects Effects

Variabel	P (sig)
Body Weight	0,000
Fat	0,000
Physical Fitness	0,000

$P < 0,05$ shows significant different

Table 3 shows the results of weight, fat and fitness differences between the control, cardio and tabata groups. The results of the analysis showed that cardio and tabata exercises significantly affected body weight as indicated by the value of $p = 0,000$ in the control group, cardio and tabata. In addition, cardio and tabata exercises significantly affected fat as indicated by $p = 0,000$ and fitness with $p = 0,000$ in the control, cardio and tabata groups.

3.4 Post Hoc Test

The post hoc test in this study used LSD test. The result of LSD test can be seen in table 4.

Table 4. The result of post hoc test

Variable	Group		P (sig)
Body weight	Control	Cardio	0,001
		Tabata	0,000
	Cardio	Tabata	0,038
Fat	Control	Cardio	0,000
		Tabata	0,000
	Cardio	Tabata	0,037
Physical fitness	Control	Cardio	0,011
		Tabata	0,031
	Cardio	Tabata	0,130

P<0,05 shows significant different

The results of LSD test on the body weight variable showed that there were significant differences between the control group and the cardio group ($p = 0.001$) and the control group with the tabata group ($p = 0,000$) and the cardio group with the tabata group ($p = 0.038$).

While the LSD test on fat variables showed significant differences between the control group and the cardio group ($p = 0,000$) and the control group with the tabata group ($p = 0,000$) and the cardio group with the tabata group ($p = 0.037$).

Then the LSD test on the fitness variable showed a significant difference between the control group and the cardio group ($p = 0.011$) and the control group with the tabata group ($p = 0.031$). But in the cardio and tabata groups there was no significant difference indicated by the value of $p = 0.130$.

4 Discussion

4.1 Effects of cardio and tabata exercises on body weight

Based on the results of research and analysis of data on body weight, the average pretest body weight of the control group was 79.78 ± 2.54 kg, the cardio group was 81.22 ± 5.49 kg and the tabata group was 79.33 ± 4.79 kg . Then the posttest results found that the mean was almost the same in the control group by 79.67 ± 2.92 kg, decreased in the cardio group by 78.33 ± 2.91 kg and the tabata group by 74.78 ± 5.07 kg (see table 1 and figure 2). From these results the difference in body weight was then sought at the pre-test and post-test in each group. Then an LSD test was performed between the cardio and control groups and also obtained a significant value ($p = 0.001$) on the weight variable. This shows that there are significant differences in body weight after doing cardio training between the control group and the cardio group.

In this study, cardio training is done by jogging and skipping with an intensity of 55% - 70% of the maximum pulse rate. Based on the intensity of the exercise performed, it is included in the moderate intensity [17]. Exercise in general contributes to

weight loss and maintenance. Moderate intensity exercise and long duration (150 minutes per week) can reduce and maintain weight better in the long run [18]. Petrofsky (2006) states that long-term exercise training can reduce weight, fat, systole and diastole blood pressure and pulse [19]. Utomo in his research also stated that aerobic exercise can prevent obesity, build muscle, improve muscle tone and reduce body fat and cholesterol levels in the blood so that it can lose weight [20]. From these various opinions there is a concordance between the results of this study with the above theory that aerobic exercise with moderate intensity can reduce and maintain ideal body weight. by 79.67 ± 2.92 kg, decreased in the cardio group by 78.33 ± 2.91 kg and the tabata group by 74.78 ± 5.07 kg.

Based on the results of this study, the mean body weight decreased after tabata training from 79.33 ± 4.79 kg to 74.78 ± 5.07 kg (see table 1 and figure 2). LSD test results also showed that there were significant differences in body weight after doing tabata exercises between the control group and the tabata group ($p = 0.038$). These results are in accordance with the research bucket (2013) that tabata exercises which include high intensity exercise can increase aerobic capacity, improve body composition, burn calories and fat, and increase the excitatory threshold of lactic acid [11].

Tabata training is one of the HIIT (High Intensity Interval Training) training methods [9]. HIIT is a type of exercise with high intensity in each session, with speed or training load in a very short time [13]. HIIT exercises performed with an intensity of 90-95% for 6 weeks can increase VO₂ max, decrease body fat percent and body mass index [14]. HIIT training methods have advantages such as a very short time, flexible and can cause the effects of injury to the musculoskeletal system very little. HIIT training is highly recommended for people with sedentary lifestyle, overweight, obesity and young adults [15].

HIIT training causes burning more calories compared to other exercises, especially after exercise. After a training period called "EPOC" which is a condition of excess oxygen after exercise. This mass lasts for 2 hours after exercise where the body stores more energy and uses it more. Because HIIT training is naturally very heavy, EPOC suppresses up to 6-15% more calories (energy expenditure) expended during exercise [21].

The best strategy for balancing energy, or making a negative energy balance in obese people is to increase energy expenditure. Increased energy expenditure can be done by increasing physical activity. Exercise and physical activity will increase energy expenditure by breaking down the body's main energy such as glycogen and triacylglycerol which will cause weight loss. Physical activity specifically stimulates the process of glycogenolysis in muscles and liver, glycolysis, oxidative phosphorylation in muscles, oxidation of fatty acids in muscles, lipolysis in adipose tissue and the citric acid cycle [22].

4.2 Effects of cardio and tabata training on fat

Based on the results of research and analysis of data on fat, the mean pretest fat of the control group was 84.78 ± 16.57 , the cardio group was 85.33 ± 8.34 and the tabata group was 85.00 ± 10.21 . Then after the treatment was carried out post test and obtained almost the same fat results in the control group by 85.00 ± 17.89 , decreased in the cardio group by 80.22 ± 9.71 and the tabata group by 77.33 ± 9.79 . (see table 1 and figure 3). From these results, the difference between fat in the pre-test and post-test in each group was searched. Then the LSD test between the cardio and control groups also obtained a significant value ($p = 0,000$) in the fat variable. This shows that there are significant differences in fat after doing cardio exercises between the control group and the cardio group.

The results of the study by Fisher et al. (2015) in obese and obese men showed that there was a significant decrease in body fat percent in subjects who were given moderate and severe intensity exercise [23]. The results of other studies in adolescents who indicated obesity by Buchan et al. (2011) also showed a decrease in body fat percent after doing moderate intensity exercise [24].

Physical activity suitable for reducing excess fat is activity in the form of endurance training or low intensity endurance. Endurance training is an activity that requires a long duration of time and low intensity, for example doing aerobics with low intensity, brisk walking, jogging, and cycling. Aerobics is a sport that if properly and properly developed can increase the level of physical fitness for the culprit [25].

Cardio training, also called aerobic exercise, is an exercise that uses energy derived from combustion with oxygen [26]. The effect of aerobic exercise is cardiorespiratory fitness, because the exercise is able to increase oxygen uptake, increase the capacity of the blood to carry oxygen and the pulse becomes lower during rest or activity. Other benefits, aerobics can increase the number of capillaries, reduce the amount of fat in the blood and increase fat-burning enzymes [27].

Aerobic exercise increases the sensitivity of β -adrenergic receptors in adipose tissue. Interestingly, in women who are trained in endurance, β -adrenergic sensitivity is increased, while the sensitivity of the anti-lipolytic α_2 receptor is reduced [28]. Increased physical activity will increase basal metabolism in body cells, this facilitates fat mobilization and oxidation especially in visceral adipose tissue which will cause a decrease in body fat levels [29]. Other factors that play a role in fat oxidation are the proliferation of skeletal muscle capillaries which increases the release of fatty acids to the muscles, an increase in carnitine transferase that facilitates the transport of fatty acids across the mitochondrial membrane, and an increase in protein-binding fatty acids that regulate myocyte fatty acid transportation [30].

Based on the results of this study, the mean weight decreased after tabata training from 85.00 ± 10.21 to 77.33 ± 9.79 (see table 1 and figure 3). LSD test results also showed that there were significant differences in body weight after doing tabata exercises between the control group and the tabata group ($p = 0.00$). This is consistent with 8 weeks of training research can reduce body fat by 44% [31]. Decreased body fat after HIIT exercise is a result of increased fat oxidation by 60% [32].

When doing HIIT metabolic rate increases after exercise between 90 minutes to 24 hours because of rapid burning of fat and calories. Metabolism during exercise increases so that it can increase the process of burning fat by stimulating the heart's system to work harder and consume more oxygen. In addition, when we rest an increase in metabolism is known as the Resting Metabolic Rate (RMR) for 24 hours after high intensity exercise [33].

The acute response after HIIT exercise is to increase the pulse rate, catecholamines, cortisol, growth hormone, blood lactate and blood glucose, glycerol and decrease parasympathetic, ATP, PCr and glycogen reserves [28]. EPOC or response after high-intensity exercise also affects fat metabolism. Fat oxidation increases because the body needs to neutralize lactic acid and H^+ to synthesize glycogen again. Increased growth hormone after high-intensity exercise can also cause increased energy expenditure and fat oxidation [28].

4.3 Effects of cardio and tabata training on fitness

In this study, fitness was measured using a 2.4 km cooper test. then the fitness results are determined from the 2.4 km run time. the faster the travel time, the better fitness. Based on the results of research and analysis of data on fitness, the average results of the pretest running time in the control group were 14.78 ± 1.11 , the cardio group was 14.78 ± 1.11 and the tabata group was 14.52 ± 0.93 . Then after the treatment was carried out post test and the results obtained running time that was not much different in the control group of 14.65 ± 0.98 , decreased in the cardio group by 13.30 ± 1.07 and the tabata group by 12.87 ± 1.00 (see table 1 and figure 4). From these results, the difference between running time during pre-test and post-test was searched for each group. Then an LSD test was performed between the cardio and control groups and also obtained a significant value ($p = 0.011$) on the fitness variable. This shows that there are significant differences in fitness after doing cardio exercises between the control group and the cardio group.

The results of this study are in accordance with the research of Tanzila et al (2018) which states that cardio or aerobic exercise with moderate intensity 3 times in 6 weeks with a duration of 15 minutes can improve cardiorespiratory fitness [34]. Kumarudin (2013) also states that there is an effect of aerobic exercise on increasing VO_2 max in adolescents aged 18-20 years with a training dose for 4 times in 4 weeks with a duration of exercise 30 minutes [35].

Moderate aerobic exercise will stimulate the heart muscles to work. Regular contraction of the heart muscle will cause hypertrophy of the heart muscle. With the increasing strength of the heart muscle, the blood pumped from the heart will be more so that the oxygen supply throughout the body will be more too. Increased oxygen supply is used to meet tissue requirements for oxygen, especially muscle tissue [36].

Based on the results of this study, the average cooper running time decreased after tabata training from 14.52 ± 0.93 to 12.87 ± 1.00 (see table 1 and figure 4). The LSD test results also showed that there were significant differences in running time after doing tabata exercises between the control group and the tabata group ($p = 0.031$). This is consistent with Wiswadewa research (2017) that HIIT training for 4

times in 6 weeks can increase Vo_2 max and speed of motion [37]. Whereas Whyte et al. (2010) also stated that high-intensity exercise for 2 weeks with a frequency of 3 times per week was able to increase VO_2 max by 7% in untrained men [38]. Dias (2017) also states that HIIT training for 12 weeks will increase Cardiorespiratory fitness (CRF) and reduce body fat in obese children [39].

HIIT training can improve BMI and increase body fitness [40]. Fitness is negatively correlated with body fat percentage. The lower the body fat percentage, the better fitness [29]. HIIT can improve cardiorespiratory fitness. This occurs because HIIT selection increases VO_2 max and causes physiologic left ventricular myocardial thickening of the heart so that the strength and ability of the heart to pump blood each contraction increases and decreases the number of beats per minute [41].

The impact of aerobic exercise on the intensity and different methods get the results that high intensity interval training (HIIT) training has proven to be effective in increasing body fitness 6-8% (VO_2 max). HIIT training for 15 weeks has also succeeded in reducing fat in the abdominal region in young women [42]. Another positive result in doing HIIT is that it can reduce fat oxidation in the body, and also reduce levels of lactic acid [43].

4.4 Comparison of cardio and tabata exercises for body weight and fat

The results showed that there were differences in body weight and fat between the cardio and tabata groups after treatment. This is evidenced by the results of the LSD test which states the value of $p = 0.022$ in the weight variable and $p = 0.037$ in the fat variable. In accordance with Zhang's research that HIIT training is better at reducing belly fat compared to moderate intensity exercise, because HIIT training time is more efficient [44].

In sports with high intensity and short duration, fulfillment of energy requirements increases almost one hundred fold [45]. Increased exercise intensity will reduce the mobilization of fatty acids from adipose tissue into the blood. This causes a shift from fat metabolism to carbohydrate metabolism. Thus the process of breaking down carbohydrates will be more dominant than the process of lipolysis in higher intensity exercises. However, in training with higher intensity such as HIIT, it expends more energy so that it will also reduce body fat more [44].

Increased intensity of exercise will also be followed by increased secretion of lipolytic hormones such as the catecholamine hormone. Catecholamine hormone stimulates the process of lipolysis through ad-adrenoceptors resulting in a reduction in body fat [46]. In addition to increasing catecholamines, higher intensity exercise such as HIIT training also increases growth hormone secretion [47]. Growth hormone is believed to increase the body's lipolysis process [48].

Exercise with high intensity will increase energy requirements, burning fat will contribute less when compared to burning carbohydrates to meet energy needs in the body. Although this fat burning contributes less when compared to burning carbohydrates when the intensity of exercise increases, the quantity of fat burned will still be greater than when exercising with low intensity. Because at the time of high intensity exercise has used a large amount of energy in muscle glycogen so when switching to

low intensity exercise with an aerobic metabolic system the source of glucose energy in the body has been depleted so that it forces the adipose tissue to release fatty acids to become an energy source. Which means that in the combination of the two metabolic processes the burning of adipose tissue is faster than exercise with the aerobic system [49].

4.5 Comparison of cardio and tabata training to fitness

The results showed that there was no difference in fitness between the cardio and tabata groups after treatment. this is evidenced by the results of the LSD test which states the value of $p = 0.130$ on the fitness variable which means not significant. This contradicts Cao's study which states that high-intensity exercise (HIIT) is better at increasing cardiorespiratory fitness (CRF) compared to moderate-intensity exercise in children and adults [50]. HIIT training has a more positive effect on increasing VO₂ max than moderate exercise both in normal and obese people [51].

However this is different from the results of a study by Carr (2011) which stated there was no difference in the increase in max VO₂ between those given HIIT training and moderate intensity training for 4 weeks [52]. That is because the VO₂ max test protocol performed is more aerobic, whereas HIIT training is more anaerobic. So what should be measured in HIIT training is the maximum anaerobic capacity [52].

Tabata training can increase aerobic capacity but is not better than moderate intensity training. Although the level of increase in aerobic capacity between tabata training and moderate intensity does not differ, tabata training increases anaerobic capacity by about 28% compared to moderate intensity exercise [11].

5 Conclusion

Tabata training method represents an effective way in reducing body weight and body fat, but it is no better than cardio training method in improving physical fitness. That's because tabata training requires more energy so that more fat burning occurs. As for fitness, tabata training is no better than cardio training because tabata training is more anaerobic, while the fitness test protocol is more aerobic.

Acknowledgment

Thanks to the head of study program Physical Education, Health and Recreation IKIP Budi Utomo Malang who has allowed his students to be the subject of this research. Then thanks to DRPM Kemenristekdikti who has provided funding for this research and other parties who have helped this research.

References

- [1] Riswanti I. Media Buletin Dan Seni Mural Dalam Upaya Meningkatkan Pengetahuan Tentang Obesitas. *J Heal Educ.* 2016;1(1):62–70.
- [2] Chiu CH, Ko MC, Wu LS, Yeh DP, Kan NW, Lee PF, et al. Benefits of different intensity of aerobic exercise in modulating body composition among obese young adults: A pilot randomized controlled trial. *Health Qual Life Outcomes.* 2017;15(1):1–9.
- [3] Wilkinson KM. Increasing obesity in children and adolescents: an alarming epidemic. Vol. 21, *JAAPA: official journal of the American Academy of Physician Assistants.* JAAPA; 2008.
- [4] Patel H, Alkhawam H, Madanieh R, Shah N, Kosmas CE, Vittorio TJ. Aerobic vs anaerobic exercise training effects on the cardiovascular system . *World J Cardiol.* 2017;9(2):134.
- [5] Yakubovich M. Aerobic and anaerobic exercise: analyzing the benefits of different forms of exercise for adults diagnosed with type 2 diabetes. *Univ Honor Theses* [Internet]. 2017;442. Available from: <http://archives.pdx.edu/ds/psu/20444>
- [6] Hackett D, Hagstrom AD. Effect of overnight fasted exercise on weight loss and body composition: A systematic review and meta-analysis. *J Funct Morphol Kinesiol.* 2017;2(4).
- [7] Kong Z, Fan X, Sun S, Song L, Shi Q, Nie J. Comparison of high-intensity interval training and moderate-to-vigorous continuous training for cardiometabolic health and exercise enjoyment in obese young women: A randomized controlled trial. *PLoS One.* 2016;11(7):1–16.
- [8] Andini A, Indra E novita. Perbedaan pengaruh frekuensi latihan senam aerobik terhadap penurunan persentase lemak tubuh dan berat badan pada members wanita. *Medikora* [Internet]. 2016;15(1):39–51. Available from: <https://journal.uny.ac.id/index.php/medikora/article/view/10071>
- [9] Tabata I. Tabata training: one of the most energetically effective high-intensity intermittent training methods. Vol. 69, *Journal of Physiological Sciences.* Springer Tokyo; 2019. p. 559–72.
- [10] Domaradzki J, Cichy I, Rokita A, Popowczak M. Effects of tabata training during physical education classes on body composition, aerobic capacity, and anaerobic performance of under-, normal-and overweight adolescents. *Int J Environ Res Public Health.* 2020;17(3).
- [11] Emberts T, Porcari J, Doberstein S, Steffen J, Foster C. Exercise intensity and energy expenditure of a tabata workout. *J Sport Sci Med.* 2013;12(3):612–3.
- [12] Viana RB, de Lira CAB, Naves JPA, Coswig VS, Del Vecchio FB, Gentil P. Tabata protocol: a review of its application, variations and outcomes. *Clin Physiol Funct Imaging.* 2019;39(1):1–8.
- [13] Alansare A, Alford K, Lee S, Church T, Jung HC. The effects of high-intensity interval training vs. Moderate-intensity continuous training on heart rate variability in physically inactive adults. *Int J Environ Res Public Health.* 2018;15(7):1–10.

- [14] Komala R, Riyadi H, Setiawan DB. LATIHAN INTENSITAS SEDANG DAN BERAT MEMPERBAIKI VO 2 MAX, INDEKS MASSA TUBUH, DAN PERSEN LEMAK TUBUH REMAJA OBES (Moderate and high exercise intensities improve VO 2 max, body mass index, and percent of body fat in obese adolescents). *J Gizi Pangan*. 2016;11(3):211–8.
- [15] Nugraha AR, Berawi KN. Pengaruh High Intensity Interval Training (HIIT) terhadap Kebugaran Kardiorespirasi. *J Major* [Internet]. 2017;6(1):1–5. Available from: <http://juke.kedokteran.unila.ac.id/index.php/majority/article/view/1521>
- [16] Widiyatno Y, Muniroh L. Dampak Pemberian Minyak Goreng Mengandung Residu Plastik Isopropyl Terhadap Blood Urea Nitrogen Creatine Tikus Putih Galur Wistar. *Agroveteriner*. 2018;7(1):15–24.
- [17] Norton K, Norton L, Sadgrove D. Position statement on physical activity and exercise intensity terminology. *J Sci Med Sport*. 2010;13(5):496–502.
- [18] Cox CE. Role of physical activity for weight loss and weight maintenance. *Diabetes Spectr*. 2017;30(3):157–60.
- [19] Petrofsky J, Batt J, Morris A. Weight loss and cardiovascular fitness during a 1-week diet and exercise program. *J Appl Res*. 2012;6(1):51–61.
- [20] Utomo GTSJSR. Latihan Senam Aerobik Untuk Menurunkan Berat Badan, Lemak, Dan Kolesterol. *J Sport Sci Fit*. 2012;1(1):6–10.
- [21] Gifari N. Efikasi Air Putih dan High Intensity Interval Training (HIIT) terhadap Perubahan Profil Lipid dan Indeks Kebugaran Kardiorespiratori. Institut Pertanian Bogor; 2016.
- [22] Petridou A, Siopi A, Mougios V. Exercise in the management of obesity. *Metabolism* [Internet]. 2019;92:163–9. Available from: <https://doi.org/10.1016/j.metabol.2018.10.009>
- [23] Fisher G, Brown AW, Bohan Brown MM, Alcorn A, Noles C, Winwood L, et al. High intensity interval- vs moderate intensity- training for improving cardiometabolic health in overweight or obese males: A Randomized controlled trial. *PLoS One*. 2015;10(10):1–15.
- [24] Buchan DS, Ollis S, Thomas NE, Buchanan N, Cooper S-M, Malina RM, et al. Physical activity interventions: effects of duration and intensity. *Scand J Med Sci Sports* [Internet]. 2011 Dec 1 [cited 2020 May 18];21(6):e341–50. Available from: <http://doi.wiley.com/10.1111/j.1600-0838.2011.01303.x>
- [25] Hartini. Perbedaan Pengaruh Latihan Senam Aerobik High Impact Dan Low Impact Terhadap Penurunan Persentase Lemak Tubuh Ditinjau Dari Body Mass Index. *J Ilm SPIRIT*. 2012;12(2):33–45.
- [26] Marcin A. 13 Benefits of Aerobic Exercise: Why Cardio Fitness Is Important [Internet]. 2018 [cited 2020 May 18]. Available from: <https://www.healthline.com/health/fitness-exercise/benefits-of-aerobic-exercise#benefits>
- [27] Awaliyah H. Pengaruh Senam Zumba Terhadap Perubahan Berat Badan Pada Mahasiswa Keperawatan Yang Melakukan Senam Zumba Di Fakultas Ilmu Kesehatan Uin Alauddin Makassar [Internet]. UIN Alauddin Makassar; 2014. Available from: <http://repositori.uin-alauddin.ac.id/6825/1/Husnul>

Awaliyah_opt.pdf

- [28] Boutcher SH. High-intensity intermittent exercise and fat loss. *J Obes.* 2011;2011(January 2011).
- [29] Dewi PK, Kania P. Hubungan Kebugaran Jasmani Dan Lemak Tubuh Pada Kelompok Senam Dan Kelompok Tidak Senam. 2016;
- [30] Horowitz JF, Klein S. Lipid metabolism during endurance exercise. *Am J Clin Nutr.* 2000;72(2 SUPPL.):558–63.
- [31] Boudou P, Sobngwi E, Mauvais-Jarvis F, Vexiau P, Gautier JF. Absence of exercise-induced variations in adiponectin levels despite decreased abdominal adiposity and improved insulin sensitivity in type 2 diabetic men. *Eur J Endocrinol.* 2003 Nov;149(5):421–4.
- [32] Perry CGR, Heigenhauser GJF, Bonen A, Spriet LL. High-intensity aerobic interval training increases fat and carbohydrate metabolic capacities in human skeletal muscle. *Appl Physiol Nutr Metab.* 2008 Dec;33(6):1112–23.
- [33] Ambarsarie, Riry; Dessy Triana NLM. The Effect Of High Intensity Interval Training On The Cardiorespiratory Resistance (Vo2 Max) Of First Year Medical Students At Faculty Of Medicine And Health Sciences University Of Bengkulu. *J Kedokt Raflesia.* 2016;2(1):63–8.
- [34] Tanzila R ayu, Chairani L, Prawesti S anggia. pengaruh latihan aerobik terhadap kebugaran kardiorespirasi pada siswa SMP di Palembang. *proceeding APKKM 6 FK Univ Muhammadiyah Surabaya.* 2018;68(April):14–22.
- [35] Kumarudin A. Pengaruh Latihan Aerobik Terhadap Peningkatan Volume Oksigen Maksimal (VO2 maks) Pada Remaja Usia 18-20 Tahun. UNIVERSITAS MUHAMMADIYAH SURAKARTA; 2013.
- [36] Alim A. Pengaruh Olahraga Terprogram Terhadap Tekanan Darah dan Daya Tahan Kardiorespirasi Pada Atlet Pelatda Sleman Cabang Tenis Lapangan. *Medikora.* 2012;VIII(2).
- [37] Wiswadewa Y, Adiputra N, Satriyasa KB, Jawi IM, Adiatmika IPG, Purnawati S. Metode High Intensity Interval Training Selama 15 Menit Dapat Meningkatkan Vo2Max Dan Kecepatan Gerak Siswa. *Sport Fit J.* 2017;5(2):30–7.
- [38] Whyte LJ, Gill JMR, Cathcart AJ. Effect of 2 weeks of sprint interval training on health-related outcomes in sedentary overweight/obese men. *Metabolism* [Internet]. 2010;59(10):1421–8. Available from: <http://dx.doi.org/10.1016/j.metabol.2010.01.002>
- [39] Dias KA, Ingul CB, Tjønnå AE, Keating SE, Gomersall SR, Follestad T, et al. Effect of High-Intensity Interval Training on Fitness, Fat Mass and Cardiometabolic Biomarkers in Children with Obesity: A Randomised Controlled Trial. *Sport Med.* 2018;48(3):733–46.
- [40] Corte de Araujo AC, Roschel H, Picanço AR, do Prado DML, Villares SMF, de Sá Pinto AL, et al. Similar health benefits of endurance and high-intensity interval training in obese children. *PLoS One.* 2012;7(8):1–8.
- [41] Nugraha E, Mulyanto R. PENGARUH LATIHAN KELINCAHAN TERHADAP KEMAMPUAN FOOTWORK PERMAINAN BULUTANGKIS (PenelitianEksperimenTerhadap Peserta Unit Kegiatan Mahasiswa Bulutangkis

- UPI Kampus Sumedang). *E J Upi*. 2018;(5):513.
- [42] Trapp EG, Chisholm DJ, Boutcher SH. Metabolic response of trained and untrained women during high-intensity intermittent cycle exercise. *Am J Physiol - Regul Integr Comp Physiol*. 2007;293(6):2370–5.
- [43] Alkahtani S, King N, Hills A, Byrne N. The effect of intensity of interval training on fat oxidation, blood lactate and rating of perceived exertion in obese men. *Obes Res Clin Pract*. 2013;7:e34.
- [44] Zhang H, Tong TK, Qiu W, Zhang X, Zhou S, Liu Y, et al. Comparable Effects of High-Intensity Interval Training and Prolonged Continuous Exercise Training on Abdominal Visceral Fat Reduction in Obese Young Women. *J Diabetes Res*. 2017;2017.
- [45] Rusdiawan A dan T. Glutamin Dalam Olahraga. *Uwais Inspirasi Indonesia*; 2019. 1-70 p.
- [46] Irving B a, Ph D, Davis CK, Brock DW, Weltman Y, Swift D, et al. Effect of exercise training intensity on abdominal visceral fat and body composition. *Med Sci Sports Exerc*. 2009;40(11):1863–72.
- [47] Pritzlaff CJ, Wideman L, Blumer J, Jensen M, Abbott RD, Gaesser GA, et al. Catecholamine release, growth hormone secretion, and energy expenditure during exercise vs. recovery in men. *J Appl Physiol* [Internet]. 2000 Sep 1 [cited 2020 May 18];89(3):937–46. Available from: <https://www.physiology.org/doi/10.1152/jappl.2000.89.3.937>
- [48] . Freda PU, Shen W, Heymsfield SB, Reyes-Vidal CM, Geer EB, Bruce JN, et al. Lower visceral and subcutaneous but higher intermuscular adipose tissue depots in patients with growth hormone and insulin-like growth factor I excess due to acromegaly. *J Clin Endocrinol Metab*. 2008;93(6):2334–43.
- [49] Hauswirth C, Marquet LA, Nesi X, Slattery K. Two Weeks of High-Intensity Interval Training in Combination With a Non-thermal Diffuse Ultrasound Device Improves Lipid Profile and Reduces Body Fat Percentage in Overweight Women. *Front Physiol*. 2019;10(October):1–12.
- [50] Cao M, Quan M, Zhuang J. Effect of high-intensity interval training versus moderate-intensity continuous training on cardiorespiratory fitness in children and adolescents: A meta-analysis. *Int J Environ Res Public Health*. 2019;16(9).
- [51] Wen D, Utesch T, Wu J, Robertson S, Liu J, Hu G, et al. Effects of different protocols of high intensity interval training for VO₂max improvements in adults: A meta-analysis of randomised controlled trials. *J Sci Med Sport* [Internet]. 2019;22(8):941–7. Available from: <https://doi.org/10.1016/j.jsams.2019.01.013>
- [52] Carr N. The Effect of High Intensity Interval Training on VO₂ Peak and Performance in Trained High School Rowers [Internet]. Arizona state university; 2011. Available from: https://repository.asu.edu/attachments/56606/content/Carr_asu_0010N_10644.pdf

Transparency Level Profile of Sports Organizations in Central Java, Indonesia

Tri Rustiadi¹, Billy Castyana², Dwi Tiga Putri³, Heny Setyawati⁴

{trirustiadi@mail.unnes.ac.id¹, billycastyana@mail.unnes.ac.id²,
dwitigaputri@mail.unnes.ac.id³}

Universitas Negeri Semarang, Semarang, Indonesia^{1,2,3,4}

Abstract. Since the beginning of the twenty-first century, cases of corruption, doping, and scoring in sports competitions, furthermore as organizational misdirection and lack of efficiency as a result of the low-level of transparency. Where, in sports organizations, transparency is one of the keys to raised organizational management. This research is aimed to urge the amount status of transparency closely held by regional sports organizations in Central Java. This quantitative study was descriptive analysis by using survey methodology. The population was thirty-five regional sport organizations in Central Java - Indonesia and with a total sampling methodology. The instrument used Action for Good Governance in the Sports Governance Observer International Sports Organization (AGGIS) developed by the Danish Institute of Sports Studies, Copenhagen - Denmark and centered on the scale of transparency that has fourteen indicators. Data analysis used was the Sports Governance Observer (SGO) Index and result was a percentage of the transparency level on every sports organization. Data showed that there are eleven regions have no Transparency, like Semarang Regency, Kendal, Demak, Tegal Regency, Tegal Municipality, Klaten, Prworejo, Kudus, Rembang, Sukoharjo, and Kebumen.

Keywords: Sport Management, Good Governance, Transparency, Central Java.

1 Introduction

Sports organizations are an integral part of the development and progress of athletes in Indonesia. However, this country is also a place for sports issues that never end. The issues that arise are terribly closely involving Sports Organizations in Indonesia and the way the Sports Organization is running. Several studies have shown that socio-cultural values derived from sports, today, are broken by corruption. It additionally relates to the exploitation of sports significantly, particularly throughout the last 20 years, where it's caused issues featured by Sports Organizations also enlarged[1].

Since the beginning of the twenty-first century, cases of corruption, doping, and scoring in sports competitions, furthermore as organizational misdirection and lack of efficiency as a result of the low-level of transparency. This is often relating to the

ignorance of sports organizations regarding their level of transparency. Where, in sports organizations, transparency is one of the keys to raised organizational management. Tahir (2010) mentioned that transparency is not solely concerning the clarity of the mechanism of formulation or analysis of policy[2], however also regarding the chance for the general public to submit proposals and criticisms. additionally, public access to the monetary management of sports organizations is also an indivisible part of transparency. This could also facilitate prevent corruption, improve the performance of structure leaders by increasing potency, and promoting the principles of excellent organizational governance[3],[4],[5]. as a result of failure to possess a decent governance system to manage and monitor a Sports Organization may end up in loss of interest from sponsors to collaborate, decrease in membership and participation, and intervention from external agencies.

The statement reflects that the dearth of transparency in Sports Organizations has the potential to possess a major negative impact on the community. However up to now, there are no studies that prove how high the amount of transparency of sports organizations, particularly in Central Java. As one of the provinces in Indonesia that has successfully scored athletes for Indonesia, Central Java ought to have a decent level of transparency. Therefore, this research is aimed to urge the amount status of transparency closely held by regional sports organizations in Central Java. The result would be an input for them in order that they are able to improve the standard of sports organizations within the future. Because sport organizations have a responsibility to the society, it is important for them to take care of it responsibly and transparently[6].

1.1 Transparency

Most notions of transparency relate to the extent to which organizations can disclose information about the policy making process, procedures, functions and performance of the organization itself[7]. Therefore, transparency has many meanings, including the availability of information about the performance of an organization. This allows individuals and / or groups outside the organization to monitor the activities and policies taken by the organization. Then Transparency can be interpreted as the availability of information about an organization that gives access to external parties to monitor the performance of that organization[8]. There are several factors that affect transparency in an organization based on previous research, including organizational position, organizational prosperity, number of members, external pressure, and organizational management commitment.

1.2 Sport Organization

Organizing is the whole process of grouping people, tools, tasks, responsibilities, and authority in such a way, so as to create an organization that can be mobilized as a unit in order to achieve predetermined goals. Organizing means uniting the main resources in an orderly way and organizing people in a pattern so that they can carry out activities to achieve their intended goals. While Jones in Harsuki (2012) provides a

definition that organization is a tool used by people to coordinate their activities to achieve something they want or value, namely to achieve their goals[9]. Furthermore according to Atmosudiro in Hasibuan (2005) organization is the structure of the division of labor and the structure of work relations between groups of position holders who work together in a certain way to jointly achieve a certain goal[10]. Based on some of the opinions above, it can be concluded that the organization is a tool or a place where managers carry out activities in an effort to achieve goals.

Organization as a vehicle to achieve goals based on a predetermined plan with there are several elements that must be in it. Organizational elements according to Hasibuan (2005) include humans (human factors), meaning that there are human elements working together, there are leaders and some are led; domicile, meaning that it has a domicile; goals, meaning that there are goals to be achieved; work, meaning that there is work to be done as well as the division of labor; structure, it means that there is a relationship and cooperation between human beings with one another; technology, there are technical unsur; environment (external social system environment), meaning that there are environments that influence each other for example there is a system of social cooperation[10].

2 Methods

This quantitative study was descriptive analysis by using survey methodology. The population was executive board member of thirty five regional sport organizations in Central Java - Indonesia and with a total sampling methodology. The instrument used Action for Good Governance in the Sports Governance Observer International Sports Organization (AGGIS) developed by the Danish Institute of Sports Studies, Copenhagen - Denmark and centered on the scale of transparency that has fourteen indicators[11], i.e. (1) publish governing documents; (2) publish sport rules; (3) publish organizational chart; (4) publish strategic plan; (5) publish agenda and MoM; (6) publish basic biography of board member; (7) publish basic information about member; (8) publish annual activity report; (9) publish standing committees report; (10) publish annual financial report; (11) publish salaries for board member and officials; (12) publish main event report; (13) media open access for general assembly; (14) contact details of board members. Every indicator is assessed as a core or additional indicator, if the indicator is classified as a core indicator and the answer from the questionnaire is "yes", then the indicator is given a score of four. If the indicator is enclosed as an additional indicator and the answer given is "yes", the researcher can provide value two. All "no" answers are going to be given a price of zero. Before the analysis began, the researcher submitted a permission letter and request letter to meet with the member of the regional sport organization in Central Java for approval to do research. Researcher solely took information on sport organizations that were willing to avoid invalid data. Data analysis used was the Sports Governance Observer (SGO) Index and result was a percentage of the transparency level on every sports organization.

3 Results

In this study, data collection was distributed on thirty-five regional sports organizations in Central Java and only twenty nine regional sports organizations were willing to be researched. Data showed that there are eleven regions have no Transparency, like Semarang Regency, Kendal, Demak, Tegal Regency, Tegal Municipality, Klaten, Purworejo, Kudus, Rembang, Sukoharjo, and Kebumen.

According to the results of previous data analysis, the level of transparency in some regions is very lacking or not even transparent at all. This is due to the lack of attention of the management of the sports organization to be able to be open to the public about the organization's activities, the list of administrators, and the budget they have. Transparency provides information that enables external stakeholders, both sports fans, the media, sponsors, governments, athletes, and the community, to monitor internal work and organizational performance. The key to transparency is accurate information.

Table 1. Transparency Points from Each Indicators

Sport Organization	AGGIS Score	Percentage (%)
Banjarnegara	2,6	65
Banyumas	0	0
Batang	0	0
Blora	0	0
Boyolali	3,5	87,5
Demak	3,1	77,5
Grobogan	0	0
Jepara	0	0
Karanganyar	2,1	52,5
Kebumen	3,6	90
Kendal	3,4	85
Klaten	0	0
Kudus	2	50
Magelang Regency	1,4	35
Pati	1,3	32,5
Pekalongan Municipality	0	0
Pekalongan Regency	1,4	35
Pemalang	2,1	52,5
Purworejo	0,8	20
Rembang	2,4	60
Salatiga	0	0
Semarang Regency	1,3	32,5
Semarang Municipality	2,8	70
Sukoharjo	1,4	35
Surakarta	1,1	27,5
Tegal Municipality	0	0
Tegal Regency	0,9	22,5
Temanggung	1,6	40
Wonosobo	2	50

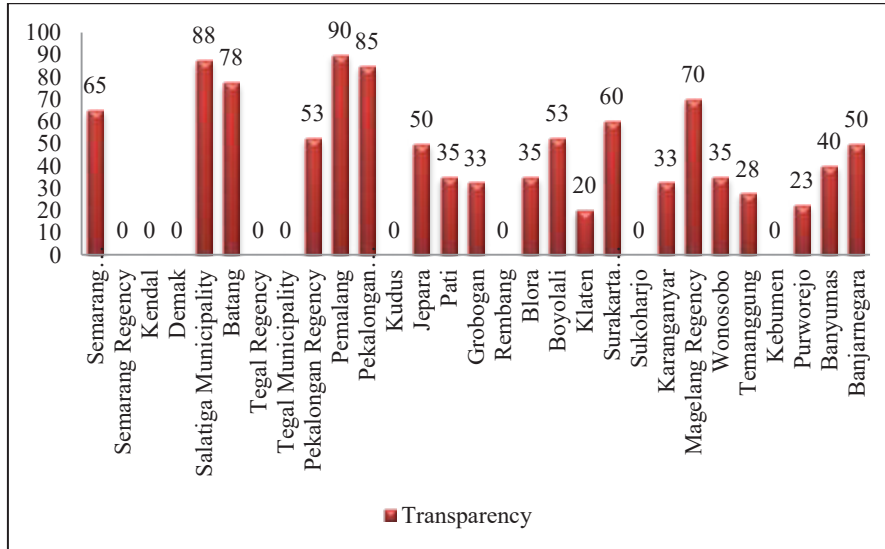

Fig. 1. Percentage of Transparency Score.

The international organization "Transparency International" (TI), one among the foremost acknowledged organizations operating with this issue, proposes mechanisms that might work as efficient ways of constructing government more transparent and preventing corruption. one in every of their reports from 2006 mentioned that Access to Public info laws; "The right of citizens to understand what governments, international organizations and personal companies do, and the way public resources are allotted, directly reflects the anti-corruption concerns"[13].

Lack of transparency may also occur because of the organization does not have a web site or social media. Public use it to reach and check the budget uses, the list of administrators, and what activities do. Many of us say that creating a web site prices tons of cash however it is truly not, because there are enough free web site or blog services. Due to the advance of technology, the using of it become necessary since people will simply see the organization activities through digital media.

Because when discussing about transparency, this also relates to how organizations communicate with stakeholders. The key to this communication is the clear explanation given by board members and how often they communicate with stakeholders, both about policy making, elections, and other matters relating to the running of the organization. In addition, board members must also regularly report on the activities and finances used[14].

We can also see transparency as the main value for being a democratic and accountable organization, but we can also see transparency as a means for an organization to gain trust from the public. With a lack of transparency, it can lead to abuse of power, mistakes in managing finances or even corruption. So, transparency is a value, but also a means to eradicate corruption.

Public trust can be achieved by the proximity of the communication media used by the government. Media that have the ability as two-way and real-time will make government easier to get the trust of the people. One of the media that can be used is Social Networking Service (SNS). A study shows that SNS that are well managed and provide information needed by the community including easy access can increase the credibility of information transparency[15].

Remember that in organizations, the system used is an open system where the organization gets huge influence from the external environment[13], one of it is the community. Because sports organizations in Indonesia still rely on income from the National Budget / Regional Budget taken from community taxes, transparency is not only reporting activities and budget use to fellow administrators but also reported to the public. This is what causes the organization to have a place so that people can access easily, wherever and whenever.

4 Conclusion

From the results of research and discussion, the conclusion is that the level of transparency of regional sports organizations in Central Java is still concerning. Many organizations assume that transparency is displaying news about activities without explaining in detail how the financial management and the selection of management. In addition, access to the community to find out where the use of organizational funds is still very difficult. There is no media that clearly explains and provides updates to the public regarding activities, budget usage, and processes that occur within the organization. Therefore, in further study, researcher needs to find out what factors influence the transparency of a sports organization.

References

- [1] Katwala, S. (2000) *Democratising global sport*, London, The foreign policy centre.
- [2] Tahir, A, (2011), *Kebijakan Public dan Penyelenggaraan Pemerintahan Daerah*, Jakarta Pusat: Pustaka Indonesia
- [3] Birkinshaw, P. (2006, January). Transparency as a human right. In *Proceedings-British Academy* (Vol. 1, No. 135, pp. 47-58). Oxford University Press.
- [4] Hood, C. (2006). Beyond exchanging first principles? Some closing comments (No. 135, pp. 211-225). Oxford University Press.
- [5] Roberts, A. (2006, January). Dashed expectations: governmental adaptation to transparency rules. In *Proceedings-British Academy* (Vol. 135, P. 107). Oxford University Press Inc.
- [6] Henry, I., & Lee, P. C. (2004). Governance and ethics in sport. *The business of sport management*, 25-41.
- [7] Curtin, D., & Meijer, A. J. (2006). Does transparency strengthen legitimacy?. *Information polity*, 11(2), 109-122.

- [8] Grimmelikhuijsen, S. G., Porumbescu, G., Hong, B., & Im, T. (2013). A Cross-National Comparative Experiment on the Effect of Transparency on Trust in Government. *Public Administration Review*, 73(4), 575-86.
- [9] Harsuki. (2012) *Pengantar Manajemen Olahraga*, Jakarta, PT. Raja Grafindo Persada.
- [10] Hasibuan, Malayu S.P. (2005) *Manajemen Sumber Daya Manusia*, Edisi Revisi. Bumi Aksara, Jakarta.
- [11] Geeraert, A. (2013). The governance agenda and its relevance for sport: introducing the four dimensions of the AGGIS sports governance observer.
- [12] Transparency International, *Using the Right to Information as an Anti-Corruption Tool*, (2006), p.5
- [13] Scott, W. R., & Davis, G. F. (2015). *Organizations and organizing: Rational, natural and open systems perspectives*. Routledge.
- [14] Bos, A., & van Eekeren, F. (2013). AGGIS: Transparency.
- [15] Park, M. J., Kang, D., Rho, J. J., & Lee, D. H. (2016). Policy role of social media in developing public trust: Twitter communication with government leaders. *Public Management Review*, 18(9), 1265-1288.

Development Model for Android-Based Bullet-Bulleted Obrain Styles

Ucok Hasian Refiater¹, James Tangkudung², Hernawan³, Firmansyah Dlish⁴

{ucokhasian_por17s3@mahasiwa.unj.ac.id¹, jamestangkudung@unj.ac.id²,
hernawan@unj.ac.id³}

Jakarta State University, Jakarta, Indonesia^{1,2,3,4}

Abstract. This study aims to develop an Android-based obrain style bullet gauge. The research method used is research and development which adopts from the theories of Borg and Gall which has 10 stages of development. The subjects were 20 male and female athletes. Data collection uses observation, questionnaire, interview and test. The data analysis technique used in this research is descriptive quantitative statistics. The average value of the results of small-scale trials with 8 subjects athletic athletes shot put number is 85.4% the category "Good" which means that the android-based shotgun gauge is "feasible" to be used as a style of shot putter obrain. So the average value of the results of large-scale group trial subjects 12 athletes athletes putting shot number 86.2% category "Good" which means that the Android-based obrain style shotgun gauge is "feasible" to be used as a gauge for shot put obrain style. The conclusion from this study is the Android-based obrain force bullet measurement test instrument is feasible to use to measure the results of obrain force shot put. The originality of this Ucok Distance Measuring (UDM) tool compared to the Alge Distance Measuring Devices (EDM) tool is that the UDM component is better by adding an android-based application and is more effective because the tool can be operated via an android smartphone.

Keywords: Android, Bullet Resistant, Measurement Model, Obrain

1 Introduction

As the development of sport science, the field of sports has changed to become very technical, challenging scientists and coaches in applying and practically applying their knowledge with the constant development of new technology. The terminology regarding technological objects for the purpose of facilitating or enhancing sports is not consistent. The term "sports technology" is used as a synonym for technical objects used for sports. Different from the more commonly used term "sports equipment", the concept of sports technology encompasses various objects which have a technology base [1]. Technology is philosophically defined as a physical instrument that can be used for problem solving [2]. A number of studies on technology in sports have previously been carried out such as: systematic reviews of global positioning systems (GPS) and micro sensor technology in team sports [3], reviews based on

motion analysis in sports [4], video usage in training [5], integrated technologies such as GPS, accelerometers and heart rate monitors in team sports [6].

At present, sports technology can be seen as part of the athlete's needs, enabling the integration of humans and objects and enabling the emergence of new discoveries through more specific analysis [7]. An interesting example of technological development taking place in sports through the application of innovative technology taken from other disciplines is the use of drones (unmanned camera sets) [8] [9]. These advances have made it possible for researchers and applied sports scientists to more easily measure key aspects of performance in the field, which often could only previously be done in a laboratory [10]. In addition to technology, athlete performance is also supported by good and tiered training. Performance and achievement of athletes must be trained to the maximum in order to get the best, this is reinforced by the opinion of James Tangkudung (2012: 63) that "achievement can only be achieved if coaching can be carried out and focused on aspects of training that fully include: athlete's personality, physical condition, technical measurement, tactical measurement and mental ability, these five aspects constitute a unified whole. 'Paralysis with analysis' is a general result that results from conscious control of a movement that is usually automatic, which is very likely caused by information overload and ongoing monitoring [11]. Therefore, a large number of studies have analyzed measurably differences in performance from year to year on throwing numbers in athletic sporting branches [12] [13] [14] [15].

One of the most prominent advances in the field of data collection and processing methods is the computer analysis system. Computer vision uses algorithms to detect identification features in video clips such as patterns or color differences [16]. A computer analysis system requires several cameras to be placed around a sports field, and can require manual input as a calibration of the game event [17]. Meanwhile, developments in the use of computer analysis technology to automate the capture of player movements continue with evaluations developed [4]. Evaluation is done by measuring students' physical fitness tests. For example, accurate player tracking data collection can be a problem when several players are collected in a small area [18] [5]. Slow-motion technology using computers also plays a role in the development of motion analysis in biomechanics and other sports sub-disciplines, with products such as Microsoft Kinect™ being used as a low-cost solution for analyzing motion [19].

The increasing distance from the throwing performance of athletes makes athletes in the athletics throwing branch realize that a more accurate and uniform device is needed to measure the distance from the throw. Finally, the development of distance measurement technology has developed rapidly. One technology that continues to develop in distance measuring devices in athletics is the Electronic measurement device (EDM). Electronic Distance Measurement (EDM), used in eight events in athletics: high jump, long jump, triple jump, pole jump, discus throwing, shot put, hammer throw, and javelin throwing. EDM tools during its development have been through many improvements to become a tool that has high precision as it is now [20].

The problem that currently exists in athletics, especially the number of throwing, is that there are still very few EDM tools owned by the PASSI organization at the provincial or district / city level in Indonesia. This certainly can affect the implementation of an athlete's training results especially when they want to take the shot put, because if using a manual test it will affect the results obtained are not accurate. In

addition, when a race event does not use accurate and digital measuring instruments, it can cause chaos because the results using manual measuring tools are not accurate.

Based on these problems, it is necessary to research the development of measuring devices with the aim that the resulting product will provide an easy and effective solution used to measure shot put skills. According to Seels and Richey in Ardani [21], development can be interpreted as a process of translating or describing design specifications into physical features. Tessmer and Richey state that development focuses not only on needs analysis but also on broad issues about initial analysis, such as contextual analysis [21]. The development of volleyball learning models produces product models learning [22]. The results of his research are the development of scoring applications in soccer games [11]. The results of his research on the development of service learning products for volleyball [23]. The results of his research are computer-based volleyball skills test instrument products [18].

Based on these problems, the researchers wanted to develop obrain style shotgun measuring devices based on Android. After this measuring device has been made and has been tested for the feasibility of the tool, it is expected that the shot gauge can be a solution to make it easier for athletes, coaches and sports teachers to evaluate the results of obrain-style shotguns.

2 Method

The research approach used in this research is research and development (Research and Development), with the reason because it is in accordance with the objectives to be achieved in the form of a development model for Android-based shotgun distance measurement tool.

The study was conducted at the East Jakarta Rawamangun Athletic Stadium with. The subjects of this study were 20 shot put athletes. The details are 17 male athletes and 3 female athletes. Data collection techniques in this study (1) observations of spaciousness where the research subjects were carried out, (2) interviews with trainers.

Observation was carried out to find out and observe the situation and its conditions regarding the instrument used and other supporting facilities at the research site. Researchers participate directly as a process of observing directly according to the circumstances in the field and Interviews were conducted with trainers

The instrument in this research development is to use several data collection instruments, including. According to Sugiyono, questionnaire is a data collection technique by giving written questions to respondents to be answered. Questionnaire can be a closed / open question / statement. According to Sugiyono, the types of questionnaires according to their shape are divided into three, viz. (1) Multiple choice questionnaire, (2) Check list. (3) Rating scale.

Data analysis includes all the activities of clarifying, analyzing, using and drawing conclusions from all data collected in action. Whereas quantitative data were obtained by giving a score on a qualitative based on a Likert scale that was converted to a scale value of 4. Percentage is intended to find out the status of something that is presented and presented as a percentage. The formula for calculating eligibility according to Sugiyono (2013) is as follows. The results of subsequent data calculations

are made in the form of a percentage multiplied by 100% and in the four categories of eligibility by using the Scale as follows. Percentage of Eligibility Category by Arikunto.

Table 1. Percentage of Eligibility

Score as a percentage	Eligibility Category
<40%	Not Good / Not Eligible
40%-55%	Poor / Inadequate
56%-75%	Good enough / decent enough
76%-100%	Good / Decent

Note: (1): Strongly disagree / very improper, (2): Not appropriate / not feasible, (3): Appropriate / feasible, (4): Very appropriate / very feasible

3 Result and Discussion

Table 2. Data on Small Scale Group Trial

No.	Aspect of Rating	Score Calculate	Percentage	Percentage	Categories
1	Aspect of Originality	87	96	84,3	Good / Decent
2	The Excellence Aspect of Innovation	124	144	86,1	Good / Decent
3	Usability Aspect	197	240	82,1	Good / Decent
4	Safety Aspects	123	144	85,4	Good / Decent
5	Aspect of Use	159	192	82,8	Good / Decent
Total Skor		683	816	85,4	Good / Decent

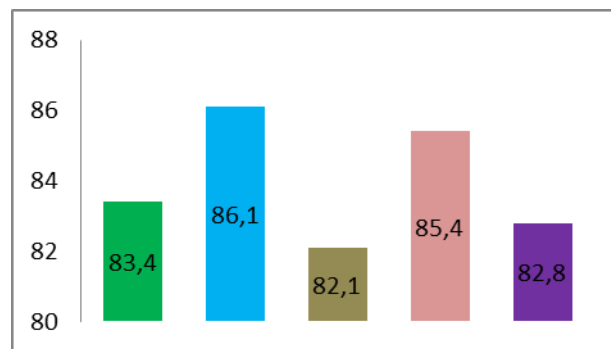

Fig. 1. Diagram of Small Scale Trial Results

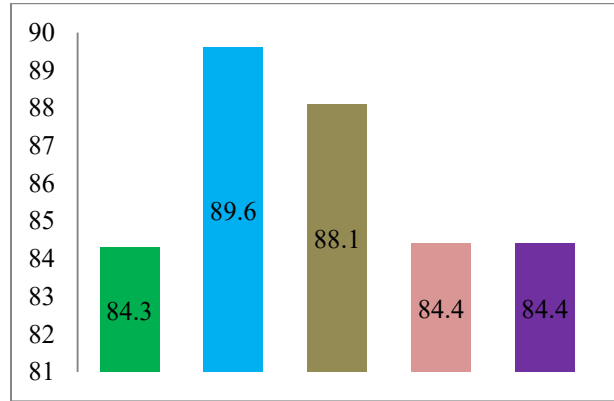

Fig. 2. Diagram of Small Large Scale Trial Results

Based on the results of large-scale group trials in the diagram above that in the aspect of originality the android-based shotgun gauge obtained 83.4% in the "Good" category means that the android-based shotgun gauge is "feasible" to proceed to the stage of tool implementation. The superiority aspect of android-based shotgun measuring devices obtaining 86.1% in the "Good" category means that digital-based athletic measurement test kits are "feasible" to proceed to the stage of tool implementation. The aspect of the use of android-based shotgun measuring instruments obtains a score of 82.1% the category of "Good" means that the android-based shotgun gauge is "feasible" to proceed to the stage of tool implementation. The safety aspect of android-based shotgun measuring device scores 85.4% in the "Good" category, meaning that the android-based shotgun gauge is "feasible" to proceed to the stage of tool implementation. The aspect of using android-based shotgun measuring devices has a value of 87.5% in the category of "Good" meaning that the android-based shotgun gauge is "feasible" to proceed to the stage of tool implementation. So the average value of the results of large-scale group trials is 85.7% the category of "Good" which means that the android-based shotgun gauge is "feasible" to proceed to the stage of tool implementation.

Based on the results of a small trial in the diagram above that in the aspect of originality the android-based shotgun gauge has an 84.3% score in the "Good" category meaning that the android-based shotgun gauge is "feasible" to proceed to the large-scale trial phase after being corrected accordingly with the advice given. The excellence aspect of android-based shotgun measuring device scores 89.6% in the category of "Good" means that the digital-based athletic measurement measuring instrument is "feasible" to proceed to the large-scale trial phase after being corrected in accordance with the advice given. The aspect of the use of android-based shotgun gauges with a score of 88.1% in the category of "Good" means that android-based shotgun gauges are "feasible" to proceed to the large-scale trial phase after being corrected in accordance with the advice given. The safety aspect of android-based shotgun gauges is 84.4% in the "Good" category, meaning that android-based shotgun gauges are "feasible" to proceed to a large-scale trial after being corrected according to the advice given. The aspect of using an android-based shotgun gauge has an 84.4% score in the "Good" category meaning that an android-based shotgun gauge is "feasible" to proceed to the large-scale trial phase after being corrected accordingly with the advice given.

ceed to a large-scale trial phase after being corrected in accordance with the advice given. So the average value of the results of small-scale trials is 86.2% the category of "Good" which means that the android-based shotgun gauge is "feasible" to proceed to the large-scale trial phase after being repaired.

Table 3. Data on Large Scale Group Trial Results

Aspect of Rating	Score Calculate	Percentage	Percentage	Categories
Aspect of Originality	87	96	84,3	Good / Decent
The Excellence Aspect of Innovation	124	144	86,1	Good / Decent
Usability Aspect	197	240	82,1	Good / Decent
<i>Safety Aspects</i>	123	144	85,4	Good / Decent
Aspect of Use	159	192	82,8	Good / Decent

This development research is based on the need that there are currently many members of the PASSI organization who do not yet have an Android-based throwing number measurement tool. So that the existence of this development product can be used by all elements and organizations of PASSI. This tool is named Ucock Distance Measuring (UDM). The Android-based obrain style shot gauge products are as follows:



Fig. 3. Ucock Disntance Measuring (UDM)

The novelty of this development research includes various aspects, in terms of technology used, in terms of the function of the tool, and the shape of the measuring instrument which certainly has a difference with the pre-existing measuring devices.

1. Novelty In Terms of Technology

Table 4. Compare the Types of Technology Used in Manufacturing Tools

Alge Distance Measuring Devices (ADMD) (Theodolites)	Ucok Distance Measuring (UDM)
Tripod	Tripod
Target	Microprocessor
Prismastic Reflector	Penahan Laser
Serial Cable	Laser
Null Modem/gender Changer	Scrup Penyambung Laser dan Penahan
Sighting Unit	Tombol pengukur
Battery Charger	Dudukan Peyambung Tripod
Battery	Led Android 14”

Based on a detailed table of the technology components used in making each measure above, there are many different types of components used. In terms of the price per unit component, of course, the UDM bullet gauge components are cheaper and easier to obtain. Then the most prominent thing is, UDM has used Android 14 "LED technology as a supporting component in the operation of tools that have been connected with the Android smartphone application.

2. Novelty of Terms of Use

Android based UDM shotgun gauge is very easy to understand in its use. Because all applications are easily accessed through the smartphone android application, so users can anytime and anywhere learn again and again. Then the features displayed on the application are also very easy to understand. So that all age groups can easily do it. After conducting the test, the data will be stored in the application automatically, making it easier for users to access the document results of the tests performed. The results of the repulsion can be directly ranked, so that the determination of the champion can be immediately known. Thus the track record of each athlete will be stored properly, the trainer will easily evaluate each time and make reference data when compiling an exercise program. Particularly for the type of typing event organizer the shot put number will be able to easily access the data of the results of the race and can be known by the audience, coaches, athletes and other media through the existing monitor display.

4 Conclusion

Based on the results of data analysis obtained from several stages both the expert validity test / expert, then proceed with small-scale group trials and large-scale group trials obtained an average score of small-scale group trial stages obtain an average so that the average value the results of small-scale trials are 85.4% the category of "Good" which means that the android-based shotgun gauge is "feasible". the average value of the results of large-scale group trials is 86.2% the category of "Good" which means that the android-based shotgun gauge is "feasible" to measure obrain-style shotguns.

References

- [1] Ebert and C. B. H, Description and evaluation of the functionality of sports products. Technische Universität München.
- [2] S. Sadjad, "Humanist and Nonhumanist Aspects of Technologies as Problem Solving Physical Instruments," *Philos. Technol.*, 2014.
- [3] Cummins, Cloe, R. Orr, H. O'Connor, and C. West, "Global Positioning Systems (GPS) and Microtechnology Sensors in Team Sports: A Systematic Review," *Sport. Med.*, vol. 43, no. 10, pp. 1025–1042, 2013.
- [4] S. Barris and C. Button, "A Review of Vision-Based Motion Analysis in Sport," *Sport. Med.*, vol. 38, no. 12, pp. 1025–1043, 2008.
- [5] W. Barry, "Development in Video Technology for Coaching," *Sport. Technol.*, vol. 1, no. 1, pp. 34–40, 2008.
- [6] L. Dellaserra, Y. G. Carla, and L. Ransdell, "USE OF Integrated Technology In Team Sports: Areview Of Opportunities,Challenges, And Future Directions For Athletes," *J. Strength Cond. Res.*, vol. 28, no. 2, pp. 556–73, 2014.
- [7] G. Gebauer, T. Alkemeyer, U. Flick, B. Bernhard, and R. Schmidt, *Fidelity to Style: The Listed Society (X-Texts on Culture and Society)*. Bielefeld, 2004.
- [8] E. Natalizio, R. Surace, V. Loscri, F. Guerriero, and T. Melodia, "Two Families of Algorithms to Film Sport Events with Flying Robots," in *Proceedings - IEEE 10th International Conference on Mobile Ad-Hoc and Sensor Systems, MASS, 2013*, pp. 319–323.
- [9] S. Inkyu and H. S. Ahn, "Visual 3D Model-Based Tracking toward Autonomous Live Sports Broadcasting Using a VTOL Unmanned Aerial Vehicle in GPS-Impaired Environments," *Int. J. Comput. Appl.*, vol. 122, no. 7, pp. 1–7, 2015.
- [10] G. Giblin, E. Tor, and L. Parrington, "The Impact of Technology on Elite Sports Performance," *Sensoria A J. Mind, Brain Cult.*, vol. 12, no. 2, pp. 2–9, 2016.
- [11] A. R. Hartati, H., S. A. Victorian, D. Destriana, and D. Destriani, "Application of Model Development of Soccer Physical Tests," in *IOP Conference Series: Materials Science and Engineering, 2018*, p. 434.
- [12] D. B. Lichtenberg and J. G. Wills, "Maximizing the Range of the Shot Put," *Am. J. Phys.*, vol. 46, no. 5, pp. 546–549, 1978.
- [13] G. E. Zatsiorsky, V. M., Lanka, and Shalmanov, "Biomechanical Analysis of Shot Putting Technique," pp. 353–388, 1981.
- [14] R. V Saraykar, "Implications of Theoretical Analysis of Throwing in Sports," *Researchgate*, 2015.
- [15] N. P. Linthorne, "Optimum Release Angle in the Shot Put," *J. Sports Sci.*, vol. 19, no. 5, pp. 359–372, 2001.
- [16] P. Janez and S. Kovačič, "Computer Vision System for Tracking Players in Sports Games," in *International Symposium on Image and Signal Processing and Analysis, ISPA, 2000*, pp. 177–182.
- [17] T. B. Moeslund, G. Thomas, and A. Hilton, *Advances in Computer Vision and Pattern Recognition*. Switzerland: Springer, 2014.

- [18] A. H. Muslimin, "Development of test devices and measurement of computer-based volleyball passing," *Dev. a Comput. Volleyb. passing test Meas. device*, vol. 17, no. 2, pp. 297–304, 2018.
- [19] Choppin, Simon, and J. Wheat, "The Potential of the Microsoft Kinect in Sports Analysis and Biomechanics," *Sport. Technol.*, vol. 6, no. 2, pp. 78–85., 2013.
- [20] R. J. M., "Recent Developments in Electronic Distance Measurement," *Aust. Surv.*, vol. 30, no. 3, pp. 170–77, 2012.
- [21] Ardani and Muryanti, *Pengembangan Multimedia Bentuk Video Compact Disc (VCD) Dalam Pelatihan Teknik Dasar Aerobic Gymnastic Untuk Anak Usia Dini*. 2015.
- [22] D. Destriani, D. Destriana, E. Switri, and H. Yusfi, "The Development of Volleyball Games Learning for Students," *J. Sport. J. Penelit. Pembelajaran*, vol. 5, no. 1, p. 16, 2019.
- [23] Destriana, E. Switri, and H. Yusfi, "Development of Overhand Serves Learning Techniques in Volleyball Game," 2020.

Improving Prime Skills of Artistic Swimming with Mental Training through Land Drill

Wasti Danardani¹, Soegiyanto K.S², Hari Setijono³, Sulaiman⁴

{wastidani@gmail.com¹, soegiyanto_ks@yahoo.com², harisetijono@yahoo.co.id³}

Universitas Pendidikan Ganesha, Buleleng, Indonesia¹

Universitas Negeri Semarang, Semarang, Indonesia²

Universitas Negeri Surabaya, Surabaya, Indonesia³

Abstract. Artistic swimming is which has two kinds of training; land training and water training (pool). In the complicated preparation toward the team in order to achieve the best performance, psychological touch becomes very important to help the swimmer's performance. This study is aimed to see the form of mental training which is done in the artistic swimming. The object of study is a member of the artistic swimming national team. The method of the study is qualitative grounded theory. Data obtained through field notes and confirmation at the informants. The results of this study indicate that mental imaging training through ground training helps swimmers to get the best movement they show. Imagery training can help the swimmers to repair the performance in the routine set. The significance of this study is to help the preparation for the swimmers' best performance through mental training.

Keywords: mental training; artistic swimming; land drill

1 Introduction

An artistic swimming is a sport branch which has an element of swimming, gymnastics, ballet, and dance. This sport branch is considered as unmeasured sport branch so that it needs a special performance factor. In Indonesia, the artistic swimming has not yet become a favourite sport in the society, so the number of human resources availability is still limited. It can be seen from the member of national team that is formed to participate in 29th Sea Games in Malaysia. There are only ten athletes from four provinces; DKI Jakarta, Jawa Barat, DI Yogyakarta, and Sulawesi Selatan.

The limitation of human resources and regeneration delays in this sport branch affect the Indonesian's achievement in the international level. In this current time, the national team mostly consists of the young swimmers rather than the experienced swimmers. It becomes a challenge for the trainers to form the excellent team. There are some supporting factors of the athletes' improvement which are needed to prepare the prima team. Training factors which comprise physical, technical, tactical, and

psychological training are considered as one procedure which needs to be implemented to reach the top achievement in the sport area [1]. The training process which has been arranged by the trainers for the swimmers includes two kinds of training, they are land training and water training (pool). Land training encompasses gymnastics, ballet, yoga, and physical conditioning. Meanwhile, water training consists of classic swimming, basic techniques of artistic swimming, and routine set. This sort of training can form the better physical ability of the artistic swimmers than another kinds of swimmer [2].

Some kinds of training which are clearly described above are intentionally prepared to improve the swimmers' physical ability, techniques, and tactic, but those are not enough to reach the psychological part of the swimmers. The studies which have been conducted previously tend to investigate the physical quality, such as what has been completed by [3]. He investigated the weakness of physical component in supporting the athletes' achievement. In the most complicated preparation of the team to achieve the prima performance, the psychological touch becomes much more important. A mental training which is known and usually practiced by the athletes is called as imagery. Imagery is a kind of mental activity in order to create or recreate the athletes' knowledge through the information received from their senses in form of meaningful move pattern which are usually practiced in the athletes' performances [4].

Imagery is considered as mental training that is usually applied to improve the athletes' performance, so imagery can be applied in artistic swimming too. The problem of this study is how to give the mental imagery training for the artistic swimmers. Therefore, the objective of this study is to investigate the forms of mental training which are practiced in the artistic swimming. The significance of this study is to help the preparation of the swimmers' prima performance through the mental training.

2 Method

This study uses a qualitative grounded theory method. The method of collecting the data of this study through field notes, interview toward the informants by taking a note and recording the information. The information is gained from the stories which have been delivered by the informants, with no treatment involved from the researchers. The technique of collecting the data is done by collecting the documentation, while the narrative note is gained from the subject of the study and narrative interview from the researchers [5]. The researchers did not give any treatment toward the object of the study, but only seek for the information. Data collection was carried out on the artistic swimming national team of Indonesia. The participant consisted of 10 swimmers of 12-24 years old and 2 coaches. The study has been conducted in the training centre of national team for the artistic swimming which is held in Yogyakarta during eight months.

The observation have been made while participating in the training center. Researchers recorded all events related to the land drill training process carried out by the team. Make notes of all swimmer's activities and how the trainer gives training. Information collected includes the understanding of land drill training, the form of

land drill training carried out in teams, land drill training procedures, and the position of land drill in supporting excellent performance.

3 Results and Discussions

3.1 The Discrepancy in Understanding the Benefit of Land Drill from the Trainer and the Athlete

Land drill training model is usually practiced in the artistic swimming. This training is considered as routine set training accompanied by the music which is practiced on land. Such kind of training can be easily achieved when the trainers and the athletes understand the purpose of a particular training program. The team which consists of ten swimmers with a range age of 14-24 years old is adequately considered as a wide range of ages. Based on the rule of FINA (Federation Internationale de Natation), the age range in the national team is the combination of three groups based on the age including group B (13-15 years old), group A (16-18 years old), and open group (over 18 years old). The difference of age and experience form the different understanding about the benefit of land drill that they feel. In the table 1, the opinion of the swimmers and the trainers about the benefit of land drill is presented.

Table 1. The Definition of Land Drill According to the Trainer and the Athlete

Respondent	Definition of Land Drill
Trainer	Land drill is an effort to help the athletes in repairing their performance when they are practicing routine set. The form of land drill training is not only to help the swimmers to remember the movements and the position pattern. But, land drill can also help to practice the movements with the right technique so that the movement form can be seen clearly and meaningful in the juries' eyes and then reach a good water level.
Athlete I (KU B)	Land drill is a kind of training that is applied to help the swimmers in remembering the movement that is going to be practiced in the routine set.
Athlete II (KU A)	Land drill is an effort that is used to help the swimmers to remember the routine set, beginning from the movement until the position displacement pattern.
Athlete III (Open)	Land drill is a particular form of training done on land to help the swimmers in rehearsing to remember the movement and the position displacement pattern so that water training (pool) becomes more neat and beautiful.

Based on table 1, it can be understood that for the swimmers, knowing the land drill is considered as the training used to help to remember the movement in the routine set that they are going to perform. A study stated that in order to help to memorize the movement, the swimmers can practice the silent land drill which means that the swimmers are not allowed to produce any voice during the land drill [6]. Actually, land drill is not only considered as a training which can help the swimmers to memorize the routine set, but it is also considered as a part of mental training. As it has been stated by the trainers, land drill can be applied to repair the performance in the routine

set including the form of hand and foot movement and the pattern of position, and to help the improvement of water level so that it does not only help to remember the routine set. Another study stated that the artistic swimmers have a focus to improve *figure* ability; in this case *figure* ability refers to the ability in performing choreography routine [7].

Land drill is a training of routine set which is practiced on land, so it is different from the way of doing routine set in water. The foot movement cannot be done similarly to the water training. Then, the foot movement can be replaced by using hand swimming. Moreover, the head position is also used to determine the position of body in the water. In order to support the performance in the competition, the right way in doing land drill is much needed. Result of study which showed that land drill is a positive effort to help to repair the movements for the swimmers [8].

3.2 The Competition Result

In this training centre, the trainers use two different methods of land drill to confront the trial stage and the main competition. Since the process of the final selection in the team formation, land drill training that is applied is unstructured land drill. This training is done until achieving the trial stage. The achievement result of the trial stage does not reach the score that is expected to be achieved by the team, so the trainers are doing the evaluation toward the training program. The evaluation is considered as feedback toward the performance and becomes the way to repair the performance, it is similar to what is revealed a study [9]. The trainers give two different forms of land drill training. First, the form of unstructured land drill training which has been given since the first time of joining the training centre until the trial competition in Japan Open. Second, the structured training form that is done after trial competition is considered as the effort to repair the swimmers' performance. From those two kinds of land drill training, it can be seen that there is difference in the score that has been obtained. The following table 2 shows the result of the competition that is participated by the swimmers.

Table 2. Score Obtained from Japan Open and Sea Games

Number of Competition	Trial Score	Competition Score	Score Gap
Solo Technical Routine	62.6229	69.2267	6.6038
Solo Free Routine	69.8000	69.2000	-0.6000
Duet Technical Routine	64.5775	68.9504	4.3729
Duet Free Routine	70.7333	71.4667	0.7334
Team Free Routine	67.9000	71.4667	3.5667

Note: The table above is the official competition result from the competition organizer (Source: www.fina.org/event/japan-open/results dan <https://kualalumpur2017.com.my/seagames-sport.cshtml>)

The result of two competitions shows that there is a change in the score that has been gained. The trial competition is accomplished in Japan Open and the main competition is completed in Sea Games. The distance between each competition is four months. In these four months the structured land drill training is applied by the train-

ers. As the result, some competitions gain the improvement, especially the competition of Free Routine team. The achievement of movement mastery needs an adequate repetition in order to reach a good result [10]. Others stated that it needs long times to reach the motion skill through imagery training [11]. Based on the score gap from five numbers of competition which are participated (Table 2), there are four numbers of competition which gain the improvement score with varying gap. The score of one number competition has decreased, it occurs in the number of solo Free Routine.

This improvement score occurs because the change of form in land drill training that has been practiced is structured land drill. The training of land drill is more emphasized on the number of duet and team so that the improvement can be seen. According to a study [12], land drill can help to improve the motion skill in the water. However, on the solo number the swimmers do not practice land drill such as what has been practiced on another numbers, so there is different result in this case. The lack of the structured land drill training causes no maximal performance. The different result on the solo number of Technical Routine, although the swimmers do not practice land drill training, they have great experiences. In this phenomenon, it can be understood that the swimmers' experiences are used to deal with their mental problems. This solo swimmers' experiences can help to build their knowledge in dealing with the situation in such a competition. In line with [13] finding, it was stated that the cognitive skill change is able to help the improvement of the performance.

3.3 The Change of Patterns in Land Drill Training

The evaluation that has been accomplished shows that all of physical and technical trainings have indicated the improvement based on the target that is arranged. However, the performance does not achieve the result based on the expectation. Mental and physical training have mutually beneficial attachment [14]. Based on this observation, the trainers believe that the mental training is not optimal to support the performance. Mental training is not only useful for the improvement of the swimmers' psychological ability, but it is also useful to improve the swimmers' skills. Coelho [15] said that mental training is able to improve the swimmers' concentration. Furthermore, the trainers develop the mental training as supporting performance in the main competition.

A kind of land drill that is applied toward this team is done through land drill training by involving the instruction when doing the training and it makes land drill training considered as imagery training. Repairing the athletes' motion performance can be accomplished through mental training [16]. The change of form in training that has been done is placed in the introduction form, before practicing land drill training, the trainers and the swimmers are doing the evaluation toward the training via video recording. By this video recording, they can see their mistakes or their improvements in the training [17]. This is aimed to make the swimmers to focus on what is going to be obtained. The following table is the comparison of the training that has been accomplished by unstructured and structured land drill.

Table 3. The Comparison Stage between Unstructured Land Drill Training and Structured Land Drill

Activities	Unstructured Land Drill	Structured Land Drill
Opening	In this stage, the trainers prepare the training and open the training section to begin land drill training. The trainers do not give the guidance in practicing land drill as a part of reinforcement. Land drill training is directly accomplished and observed.	In this stage, the trainers open the training section and provide the information about the training activities. For example, "In land drill training today, let's imagine the competition situation and we are ready to get down in the competition". Reinforcement stage is done a minute before land drill is started. The trainers are doing reinforcement by following steps: 1. The swimmers are ready in their position and getting the instruction to close their eyes. 2. Next, the trainers give the instructions: a. "Imagine that you are in the competition arena" b. "You are ready to go to the arena, focus on your performance. The audience tribune is full of the opponent's supporters, so keep your concentration" c. "Imagine a beautiful path into the arena, imagine of doing choreography and its element with full of energy, and a good water level" d. "Although you are doing with the help of hand movement, you have to imagine that it is the movement element that you do" e. "This is your three minutes-struggle which cannot be repeated. Do your best" 3. After instilling the reinforcement to the swimmers, it is then continued by the land drill training.
Reinforcement		
Realization	Doing land drill. 1. It is started by walking into the arena, configuring the opening movement until the position is ready. 2. The soundtrack is played and the swimmers start to do routine choreography until the music is ended.	Doing land drill. 1. It is started by walking into the arena, configuring the opening movement until the position is ready. 2. The soundtrack is played and then the swimmers start to do routine choreography until the music is ended.
Closing	In the end of the training, the trainers deliver the evaluation and motivate the swimmers to come in the next training.	In the end of the training, the trainers deliver the evaluation and motivate the swimmers to come in the next training.

This team is dominated by the young swimmers which includes not only from the aspect of age, but also from the aspect of experience. A kind of mental imagery completed with the guidance is believed as the right choice for the young athletes, this is in line with Setyawati's opinion [18]. Mental training is an effort to help the sport participant in improving the mental skill to achieve the successful performance and personal prosperity [19]. The ability of imagery has a significant relationship toward the athlete's movement skill [20]. In this case, it has been explained that not only the athletes who need the mental training, but also the trainers and those who are involved in handling the team. It is deemed necessary to know and understand about the mental

training through land drill. In preparing the team, the trainers are also able to arrange the mental training and its period like physical training. Setyobroto [21] explained that the treatment of mental training is a systematic treatment which takes a long time, but the result is more convincing in order to improve the athletes' performance.

The phenomenon found in this study is the application of land drill in every choreography training of routine set. Such kind of training form is usually practiced, but not really understood its benefit in the achievement of prima performance. The way to practice land drill training is same as the training of mental kinaesthetic imagery. Moreover, the involvement of the movement done by the trainers can help the swimmers to shape the description of the right movement. This is in line with Firmansyah's study [22]; the training of kinaesthetic imagery provides the real experience to the athletes.

Land drill training becomes an alternative to give the psychological training to the swimmers. The trainers do not need to provide a particular time to give the mental training, because it has been included in land drill training. The training of mental imagery through land drill training can be achieved by arranging the training with some steps which is similar to imagery training. Therefore, land drill training form becomes more structured and well-directed.

The result of this study helps the trainers in giving mental training to the swimmers. Doing land drill training with the right direction can help to achieve the prima skill. Similar to Hidayat's study [23], it was explained that mental imagery training is able to improve the athlete's motoric skills. Moreover, mental imagery training is also beneficial for the swimmers to create mind recording about the movement skill, not only to remember but to create the psychological experience also, so that it helps to prepare the excellent performance.

According to Bompa and Haff [24], all planning of physical, physical, and mental trainings are arranged before the training is held. These three kinds of training are completed since the beginning of the training program. Through land drill, the artistic swimmers' mental training has been accomplished based on the training program. This training is done without providing a particular separated time from the whole training times. The program of mental imagery training through land drill training to achieve prima performance has run for the artistic swimming.

4 Conclusion

To get excellent skills in artistic swimming consists of three forms of training, they are training in pool, training on land and land drill. Swimmers have different understanding of land drill according to age group. In the younger age groups, land drill is understood as a form of exercise for remembering routine set choreography. In the middle age group, the existing understanding is added by calculating the formation changes. The senior age group has a broader understanding to calculate neat and beautiful. The land drill training model is designed in detail with structured instructions to help athletes master the routine set. So it can be seen an increase in scores achieved in the two competitions that were followed.

Land drill by providing clear instructions in a structured manner including a form of mental training. The mental exercise be intended is imagery. This is done

during the training period, by providing a certain time in the training schedule. In the future, research can be developed in the right time to conduct a land drill. Or other research that leads to the development of the abilities of artistic swimming athletes.

Acknowledgement

This paper would not have been realized without the support of National Swimming Federation of Indonesia, overshadowing the Indonesian national artistic swimming team as a research site. Facilitating and helping me from early observation until the completion of this paper. Proud and saluted to all members of the Indonesian national artistic swimming team involved in preparation for the 2017 sea games. They provided many benefits for my research, as research informants. Not to forget miss Ragil and miss Dhanisa as coaches and miss Shelvy as supervisor team, a great deal of thanks for the information and support of the study. Great thanks to colleagues and lecturers in the graduate and faculty of sports science Semarang State University providing support during this research. The opportunity to take this research as a way for me to introduce artistic swimming to sports enthusiasts in Indonesia.

References

- [1] Bompa., Tudor O., and Haff., G Gregory. 2009. *Periodization Theory and Methodology of Training*. Fifth Edition. Human Kinetics. ISBN-13: 978-0-7360-7483-4.
- [2] Dodigovic, Lucija., and Sindik, Josko. 2015. Comparison Of Selected Health And Morphological Parameters Between Classic Swimming And Synchronized Swimming. *Sport Scientific And Practical Aspect*, 12(2): 5-9.
- [3] Soegiyanto, Ks. 2011. Kondisi Atlet Panahan Program Atlet Andalan Nasional Indonesia Emas (Prima). *Media Ilmu Keolahragaan*. 1(1): 28-36.
- [4] Komarudin. 2013. *Psikologi Olahraga, Latihan Mental Dalam Olahraga Kompetitif*. Bandung. PT. Remaja Rosdakarya. ISBN 978-979-692-147-8
- [5] Creswell, John. 2015. *Riset Pendidikan, Perencanaan, Pelaksanaan, dan Evaluasi Riset Kualitatif & Kuantitatif, Edisi Kelima*. Yogyakarta. Pustaka Pelajar
- [6] Bepalov, Boris., and Leanov, Sergey. 2012. Characteristic of Silent Counting in Synchronized Swimmers. *Psychology in Russia : State of Art*, 1(5), 2012, pp. 498-510(13).
- [7] Vassilios, Thanopoulos., Chyssoula, Chairpoulou., Shopia, Ktena., and Georgia, Rozi. 2016. Differences In Physiological Responses of Synchronized Swimming Athletes And Female Swimmers. Published in the Russian Federation. *European Journal of Physical Education and Sport* Has been issued since 2013. -12(2):58-62
- [8] Dingley, A. A., Pyne, D., and Burkett, B. 2014. Dry-land Bilateral Hand-force Production and Swimming Performance in Paralympic Swimmers. *Int J Sports Med* 35: 949–953.
- [9] Setyawati, H . 2011. Pemberian Umpan Balik Dalam Belajar Gerak. *Journal of Physical Education Health and Sport* 1 (1): 38-45

- [10] Saifudin, Mohamad., Soegiyanto, Ks., dan Sugiharto. 2013. Latihan Massed Practice dan Distribute Practice untuk Akurasi Tendangan ke Gawang. *Jurnal Media Ilmu Keolahragaan Indonesia* , 3(2):119-123
- [11] Oostra, Kristine M., Oomen, Anne., Vanderstraeten, Guy., And Vingerhoets, Guy. 2015. Influence Of Motor Imagery Training On Gait Rehabilitation In Sub-Acute Stroke: A Randomized Controlled Trial. *J Rehabil Med* - 47: 204–209. doi: 10.2340/16501977-1908
- [12] Zhang, Peng. 2014. Basic Land Drills For Swimming Stroke Acquisition. Published in *JTRM in Kinesiology* an online peer-reviewed research and practice journal - May 22, 2014. ISSN 0778-3906.
- [13] Adler, A. B., Bliese, P. D., Pickering, M. A., Hammermeister, J., Williams, J., Harada, C., Csoka, L., Holliday, B., & Ohlson, C. 2015. - Mental Skills Training With Basic Combat Training Soldiers: A Group-Randomized Trial. *Journal of Applied Psychology*, 100(6):1752-64.
- [14] Debarnot, Ursula., Abichou, Kouloud., Kalenzaga, Sandrine., Sperduti, Marco., and Piolino, Pascale. 2015. Variable motor imagery training induces sleep memory consolidation and transfer improvements. *Neurobiology of Learning and Memory*. 119 - 85–92. doi: 10.1016/j.nlm.2014.12.010
- [15] Coelho, Ricardo Weigert., Kuczynski, Katia Maria., Paes, Mayara Juliana., Greboggy, Dênis de Lima., dos Santos, Priscilla Bertoldo., Rosa, Ana Paula Dalazuana Souza., and Stefanello, Joice Mara Facco. 2014. Effect of a Mental Training Program on Salivary Cortisol in Volleyball Players. -. *Journal of the American Society of Exercise Physiologists*. 17 (3), 46-57.
- [16] Arvinen-Barrow, Monna., Clement, Damien., Hamson-Utley, Jennifer J., Zakrajsek, Rebecca A., Lee, Sae-Mi., Kamphoff, Cindra., Lintunen, Taru., Hemmings, Brian., and Martin, Scott B. 2015. Athletes' Use of Mental Skills During Sport Injury Rehabilitation. *Journal of Sport Rehabilitation, JSR* 24 (2), 189 -197.
- [17] Jerszyński, Damian., Antosiak-Cyrak, Katarzyna., Habiera, Małgorzata., Wochna, Krystian., and Rostkowska, Elżbieta. 2013. Changes in Selected Parameters of Swimming Technique in the Back Crawl and the Front Crawl in Young Novice Swimmers. *Journal of Human Kinetics*, 37: 161-171.. DOI:10.2478/hukin-2013-0037
- [18] Setyawati, H. 2014. Strategi Intervensi Peningkatan Rasa Percaya Diri Melalui Imagery Training Pada Atlet Wushu Jawa Tengah. *Journal of Physical Education Health and Sport*. 1(1): 48-59.
- [19] Tenenbaum, Gershon., and Eklund, Robert C. 2007. *Handbook Sport Psychology*. Third Edition. New Jersey. John Wiley & Sons, Inc. ISBN-13: 978-0-471-73811-4.
- [20] Battaglia, Claudia., D'Artibale, Emanuele., Fiorilli, Giovanni., Piazza, Marina., Tsopani, Despina., Giombini, Arrigo., Calcagno, Giuseppe., di Cagno, Alessandra. 2014. Use of video observation and motor imagery on jumping performance in national rhythmic gymnastics athletes. *Hum. Mov. Sci.* 38, 225–234.
- [21] Setyobroto, Sudibyo. 2001. *Mental Training*. Jakarta, Penerbit Solo.

- [22] Firmansyah, Helmy. 2011. Perbedaan Pengaruh Latihan Imagery Dan Tanpa Latihan Imagery Terhadap Keterampilan Senam Dan Kepercayaan Diri Atlet. *Jurnal Olahraga Prestasi*, 7(1), 1-10.
- [23] Hidayat, Yusup. 2010. Imajeri Mental Dan Keterampilan Motorik (Studi Meta Analisis). *Jurnal Olahraga Prestasi*, 6(1), 1-9.
- [24] Bompa., Tudor O., and Haff., G Gregory. 2009. *Periodization Theory and Methodology of Training*. Fifth Edition. Human Kinetics. ISBN-13: 978-0-7360-7483-4.

Sociometry of a Women Handball Team

Wiga Nurlatifa Romadhoni¹, Nasuka Nasuka², Erwin Nizar Priambodo³

{wiganurlatifa@mail.unnes.ac.id¹, nasuka@mail.unnes.ac.id², erwinnizara1@mail.unnes.ac.id³}

Universitas Negeri Semarang, Semarang, Indonesia^{1,2,3}

Abstract. Sociometry is one of a research method for measurement and assessment of group cohesion and communications between population units. The main purpose of the study is to determine mutual choices, characteristics of the group relationships and interpersonal relationships. In handball, interpersonal relationships is important in building team structures to achieve high goals. The research information base consisted of survey data from 15 athlete from the women handball team. After analyzing these factors, we can see the group leader, group cohesion, and marginalized individuals of the team. By analyzing interpersonal relationships between team members, we can improve group cohesion that can affect team outcomes. The conclusions from applying the sociometry test is the test can help us to define preferences for the team captain or other social problems in the group we want to investigate and whether the group is united or divided.

Keywords: sociometry, interpersonal relationships, sports team, group cohesion.

1 Introduction

A successful sports team surely has a good communication between the players, strong leaders and good interpersonal relationships between team members. Harmonization of interpersonal relationships can leads to achieve high goals. To find out how good the communication or interpersonal relationships between the players of course in the process we needed a method to find out. Sociometry is one of a research method for measurement and assessment of cohesion of specific social groups and communications between units of the population [1]. Group cohesion is very important in the evolution of performance as a group where we can find positive relationships as friendships, sympathy and cooperation [2].

In the works of Ussorowska 2016, studying intra-group relationships between players can used sociometry test by Moreno as the main method [3]. Sociometry is based on the fact that people make choices in interpersonal relationships. When gathered, they will choose whether to sit or stand, choose who is friends or who is not friendly, who is the central figure or who is rejected (not liked) in the group or who is isolated [4]. By this method we can investigated the subject opinions, thoughts, views, impressions, and we got to know their interpersonal relationships in order to analyze the personality.

The main purpose of the study is to determine mutual choice, characteristics of group relationships and interpersonal relationships between team members in women's handball team. Handball is a sport whose main goal is to score as many goals or scores as possible

through dribbling, passing and throwing the ball into the goal. Where there are teams that try to score goals while the other team tries to clear the ball and keep the defense [5]. The performance of a game on a handball team is determined by the player's technical ability, tactical ability, player cohesiveness, psychological or social and physical characteristics of the player itself. All of these elements are very important and are quite related in a very complex handball team in it [6].

In handball, interpersonal relationships is important in building team structure to achieve high goals. The survey data consists from 15 athlete is the information base of the research at women handball team at Semarang, Indonesia. This research methodology of structural analysis small group based on sociometry method. We can see the group leader, group cohesion, and marginalized individuals of the women handball team after analyzing these factors. By analyzing interpersonal relationships between player, we can stimulate positive relationships and improve group cohesion that can affect the results of the team. The conclusions from applying sociometry test is the test can help us to define preferences for the team captain or other social problems in the group we want to investigate and whether the group is united or divided. The connection with the game of handball, with knowledge of the factors that influence interpersonal relationships, allows the coach or the members of the handball team to influence them in eliminating unwanted behavior. In addition, thanks to the awareness of forming and monitoring the right attitude in the team, the coach is able to improve a player's interpersonal situation. By doing this, the general atmosphere within the handball team will improve, so that it correlates with the effectiveness of the team's activities in achieving the highest goals.

2 Material and methods

The research methodology used in this study is based on existing sociometry methods and consists of survey data from 15 athletes from the team of women's handball. Our research took place in Semarang, Indonesia with our women handball team between April 2020 and early June 2020 with 15 players aged between 18 and 23 years old, with a handball experience of 2-5 years. Based on the methods and clause specified in the work of Wäsche (2017) [7], Herbison (2018) [8], Timushkin (2018) [9], Sopa (2018) [10] and Dontsov (2018) [11], we developed a sociometric survey to determine the likes of the members of the handball women team.

This survey also includes the following types of questions based on the methods and principles set out in the work of Viktorovna 2019 [12] and Sopa 2018 [13].

Table 1. Questions and answers option for sociometry researchs

Questions	Answers option
Which athlete's members do you prefer to work out and you prefer can lead the team?	1..... (+3)
	2..... (+2)
	3..... (+1)
	you can choose 3 team members, the first pick is the person you like the most

*compiled by the authors

Furthermore as noted in the works of Viktorovna 2019, in this case it is also necessary to create a matrix of respondents' choices for each question and the need to count the number of mutual choices, made and choices received.

it is necessary to construct a matrix of respondents' choices for each question and calculate the amounts of received, made and mutual choices.

Data collected by the sociometry questionnaire is still difficult to analyze and understand if it has not been processed. So that the sociometric data is easily understood, then the data is presented in tabular form (sociometric matrix) and image form (sociogram). After the sociometry questionnaire was filled out, it was then collected and processed to get an overview of the data.

Processing results of sociometric instruments refer to the following steps: {a}. Prepare a sociometric table containing the name of the voter and the name chosen, {b}. enter the data obtained from the sociometry questionnaire into the table with the provisions of number 1 for the first choice (1), number 2 for the second choice (2), number 3 for the third choice (3). The tabulation data for the directional vote is calculated as follows: for the first choice (1) a score of three (+3) is given, for the second choice (2) a score of two (+2) is given, and the third option is given a score of one (+1), and {c}. From the tabulations that are poured in the form of a sociogram using the sociogram application that is useful to see the mutual choice, characteristics of the group relationships and interpersonal relationships between team members.

3 Results

The next step on the basis of the data in our study is to built our athlete's response and build a sociometric matrix. In Table. 2 we listed the subjects with a letter in the first column and assign numbers in sequence.

Table 2. Sociometric matrix

Subjects (voter)	(Selected)														
	A	B	C	D	E	F	G	H	I	J	K	L	M	N	O
No.	1	2	3	4	5	6	7	8	9	10	11	12	13	14	15
A. (1)	X			3	1							2			
B. (2)	1	X	3		2										
C. (3)	2		X	3	1										
D. (4)	1			X	2										3
E. (5)	2				X	3					1				
F. (6)				3		X			1						2
G. (7)	2				1		X			3					
H. (8)	3		2		1			X							
I. (9)	1			3	2				X						
J. (10)			3		1					X	2				
K. (11)				1	2					3	X				
L. (12)	1				2							X	3		
M. (13)			1		2				3					X	
N. (14)	3				1		2								X
O. (15)	1											2	3		X

Based on the selection matrix, a selection chart between team players is built for selection for criteria. The links in group or team are quite extensive, as can be seen from Figure 1. It can be seen that there is an interpersonal relationship between team players, even though there are three isolated athletes (B, H, N) because all the three are not selected as training buddy during training and as leaders. As can be seen from Figure 1 this criterion reveals the highest saturation of bonds, because the links in the team are quite extensive. It can be seen that communication links now cover almost all team members, although there are three (B, H, N) isolated team members that no one has chosen as training partners or as leaders of the team. It can be seen in Table 3 that shows the distribution of each popular, moderate and unpopular team players according to the criteria "partners during training and as leaders in teams".

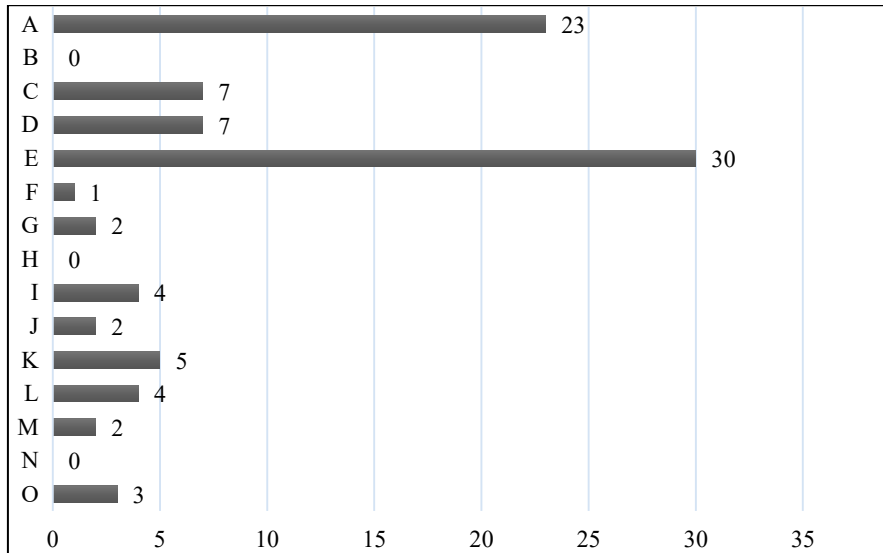

Fig. 1. Team members score selection chart

Table 3. Score & Index CS (Choice Status)

No.	Subject Name	SCORE	Nxp	Index CS
1	A	23	45	0,511111111
2	B	0	45	0
3	C	7	45	0,155555556
4	D	7	45	0,155555556
5	E	30	45	0,666666667
6	F	1	45	0,022222222
7	G	2	45	0,044444444
8	H	0	45	0
9	I	4	45	0,088888889
10	J	2	45	0,044444444
11	K	5	45	0,111111111
12	L	4	45	0,088888889
13	M	2	45	0,044444444
14	N	0	45	0
15	O	3	45	0,066666667

According to the survey results using matrix of choices, four members of the women's handball team (E, A, C, D) can be distinguished who are most popular to be a partners during workout and as a leaders in the team.

The selection of a sociograms (Figure. 1) enables a comparative analysis of the structures of relationship within the teams and can provide a visuals representation for group leaders and interpersonal relationships of team players who also consider their popularity.

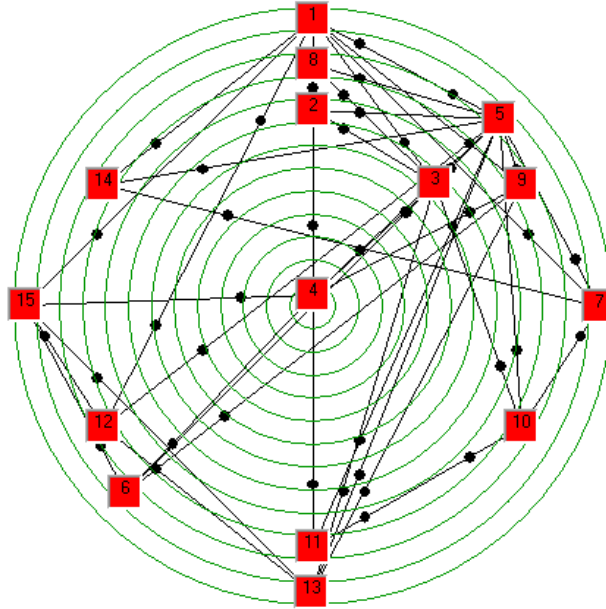

Fig. 2. Sociogram elections

Conducting this sociometry research highlighted the importance of the survey method in scientific research in the field sports team especially in handball. Finding the best partners for sports or workout and the right leader requires communication in its implementation on the process. The group constitutes the basic psychosocial reality of sports activities, its cohesion and capacity depending very much on the performance and satisfaction of the athletes. The commonly known group situations can be characterized as "united", "divided", "confused" or working to acquire a personality [14].

This research can analyze the most popular team member based on the questions, whether the team members prefer to interact in training or workout with several people and choose the right leaders. Some team members are currently falling from the communication structure (B, H, N). There are a number of three players from team members who have a total score of zero from the question (namely: B, H, N), with these results it is possible to expect that there will be developments in the team, so that later the results can be used as evaluations into groups. So, based on that we can conclude that the sociometry in the women handball team is quite favorable.

4 Conclusions

The sociometry test is the test can help us to define preferences for the team captain or other social problem in the group we want to investigate and whether the group is united or divide.

Acknowledgments

We would like to thank Faculty of Sports Science, Universitas Negeri Semarang, Indonesia for the funding.

References

- [1] Viktorovna VI, Vladimirovna VT, Nikolaevna SN. Sociometry of a volleyball team. *J Phys Educ Sport*. 2019;19 (2): 1104–11.
- [2] Sopa, I.S. & Pomohaci M. *Developing Cohesion in Sportive Group through the Socializing Means of Motor Activities*. 2015. Bologna: Medimond Publishing Company by Editografica, p. 135.
- [3] Ussorowska, A., Mieszkowska, M., & Graczyk, M. Analiza socjometryczna w ocenie grupy społecznej i budowaniu zespołu sportowego= Sociometry in the assessment of social group and sport team building. 2016. *Journal of Education, Health and Sport*, 6(8): 719-733.
- [4] Viktorovna VI, Vladimirovna VT, Nikolaevna SN. Sociometry of a volleyball team. *J Phys Educ Sport*. 2019;19 (2): 1104–11.
- [5] Ziv, G. & Lidor, R. Physical characteristics, physiological attributes, and on-court performances of handball players: a review. *Eur J Sport Sci*. 2009. 9(6): 375–86.
- [6] Michalsik LB, Madsen K, Aagaard P. Technical match characteristics and influence of body anthropometry on playing performance in male elite team handball. *J Strength Cond Res*. 2015. 29 (2): 416–28.
- [7] Wäsche, H., Dickson, G., Woll, A., & Brandes, U. (2017). Social network analysis in sport research: an emerging paradigm, *European Journal for Sport and Society*, 14(2), 138-165.
- [8] Herbison, J. D., Vierimaa, M., Côté, J., & Martin, L. J. (2018), The dynamic nature of connection and its relation to character in youth sport, *International Journal of Sport and Exercise Psychology*, 1-10.
- [9] Timushkin, A. V., & Kuzmin, A. M. (2018), Determining the leader in a professional team in the relationship process in a sports team. *News of the Saratov University. New series. Philosophy Series. Psychology. Pedagogy*, 18 (2).
- [10] Sopa, I. S., & Pomohaci, M. (2018), Discovering the leader of a volleyball team using the sociometric survey method. *Timisoara Physical Education & Rehabilitation Journal*, 10(3).
- [11] Dontsov, D. A., & Sagova, Z. A. (2018), Methods of social and psychological diagnostics of sports groups and groups of younger schoolchildren, adolescents and youths, *School technology*, 1, 89-102.
- [12] Viktorovna VI, Vladimirovna VT, Nikolaevna SN. Sociometry of a volleyball team. *J Phys Educ Sport*. 2019;19 (2): 1104–11.
- [13] Sopa, I. S. & Pomohaci, M. Discovering the leader of a volleyball team using the sociometric survey method. *Timisoara Physical Education & Rehabilitation Journal*. 2018. 10(3).
- [14] William A. Darity. (2008). *International Encyclopedia of the Social Sciences: 2nd Edition*. Macmillan Reference USA.

Analysis of Physicochemical and Sensory Quality of Chia Seeds Sport Energy Gel (*Salvia hispanica*, L.) during Storage

Yanesti Nuravianda Lestari¹, Eko Farida², Nur Fauzi³, Fadjrul Falah Fikri⁴
{yanestnur@mail.unnes.ac.id¹, f_rida_mw@yahoo.com², nurfauzi@students.unnes.ac.id³}

Universitas Negeri Semarang, Semarang, Indonesia^{1,2,3,4}

Abstract. Sports drinks could be applied as sports food for athletes during the training and recovery stage. This study aimed to formulate a sports energy gel from Chia seeds (*Salvia hispanica*, L.). This study conducted on a total of 18 treatments were consist of 2 factors (hydrocolloid type and storage temperature). The observed characteristics were pH, total soluble solids (TSS), and physical and sensory changes due to storage. The results show that there is a significant difference in the pH and the total soluble solids. During storage, the color is getting darker, cloudy, froth, and rolled, and its acids and alcohol odor increased in all the treatment stored at room temperature compared with refrigerator temperature storage. It can conclude that different types of hydrocolloid and storage temperatures can significantly decrease the physical quality and sensory characteristics.

Keywords: sports energy gel, hydrocolloids, sensory characteristics.

1 Introduction

Sports drinks created to revitalize the electrolyte and keep the body hydrated. Sports drinks could be applied as sports food for athletes during the training and recovery stage. The most important ingredient of sports drinks are carbohydrates, mainly glucose and electrolyte (sodium, potassium, and magnesium). Athletes need sports drinks during hard physical activity to avoid hyponatremia, which causes fatal because of a lack of sodium level in the blood. The first sports drink produced for the football team in Florida is Gatorade, which has liquid form. Sports drinks are now growing in another form, such as sports gel.[1] Sports gel has gooey consistency and concentrated carbohydrate, usually available in a single pack.

The component of a food ingredient that can use as a source of energy and nutrient in formulating sports drinks is Chia seeds (*Salvia hispanica* L.). Chia seeds have a small oval shape, usually black, gray, or brown, with few white spots. In the water, Chia seeds can expand and produce clear white mucus. Chia seeds are also often used as components in the manufacture of certain food products and function as thickener, emulsifiers, or stabilizers.[2],[3] Chia seeds are high in fiber, protein, omega-3, gluten-free, rich in vitamins, minerals, and antioxidants, namely polyphenols, tocopherols, and isoflavones.[4],[5]

Athletes are not able to consume much fluid in one drink, especially during vigorous exercise. Athletes need adequate energy, nutrients, and electrolytes to support their performance during training. One of the sports drink that can be applied on athletes is sports energy gel, which produces with hydrocolloid addition. The hydrocolloid is a component to bind the water and form gooey consistency. The hydrocolloid also uses as a thickener, gelling agent, emulsifier, stabilizer, and coating, for example, carboxymethyl cellulose (CMC), gelatin, chitosan, gum, pectin, and starch.[6] This research was conduct to develop and produce sports energy gel based on Chia seeds and hydrocolloid addition, which has the best physicochemical and sensory quality.

2 Material and methods

This Complete Random Design study is consists of two factors, hydrocolloid type and storage temperature. The hydrocolloid (H) type factor consists of 3 levels, while the storage temperature factor (T) consists of 2 levels. Each treatment level replicated three times, so that there are total 18 treatments.

2.1 Preparation of sport energy gel

The main ingredients used in the preparation of sports energy gel are organic Chia seeds (*Salvia hispanica*, L) purchased at local supermarkets. The hydrocolloids used in this beverage formulation are xanthan gum, pectin, and Carboxymethyl Cellulose (CMC). Other ingredients used as beverage composition are dragon fruit juice and cucumber juice.[1],[2] The composition of Chia seeds-based sports energy gel presented in **Table 1**.

Table 1. The Composition of Chia Seeds-based Sport Energy Gel.

Ingredients	Amount
Chia seeds (g)	4
Maltodextrin (g)	15
Dragon fruit juice (mL)	5
Cucumber juice (mL)	5
Hydrocolloids (%)	0.1%
Water (mL)	200

The production of a sports energy gel is done by mixing Chia seeds, maltodextrin, dragonfruit juice, cucumber juice, and added warm water as much as 200 mL. The mixture homogenized and then added 0.1% hydrocolloids (H₁: Xanthan Gum; H₂: Pectin; H₃: CMC). The mixture then homogenized.

2.2 Storage of sport energy gel

Sport Energy gels that have formulated and added hydrocolloids then stored for seven days at different storage temperatures, which are room temperature 15-30°C (T₁) and refrigerator temperature 8°C (T₂). The observation of the characteristic changes occurred four times, there is the day before storage (day 0) and during storage at day 3th, 5th, and 7th.

2.3 Physicochemical analysis of sport energy gel

Acidity (pH). The pH of a sports energy gel is measured using a pH-meter. Before measuring the sample, the pH-meter calibrated first using a buffer solution. The pH-meter dipped in 100 mL of a homogenized sample.[3]

Total Soluble Solid (TSS). The Total Soluble Solid (TSS) of sports energy gel is measured using a hand refractometer. Before measuring the sample, the refractometer calibrated first using aqua dest until the reading results indicate a zero value. 1-2 drops shed the sample on the glass prism. Cover the glass prism slowly and make sure the sample fills the entire glass surface prism. The Total Soluble Solid (TSS) level is read through the binoculars and will designate as Brix [4].

2.4 Sensory analysis of sport energy gel

Organoleptic Analysis. Organoleptic analysis of sports energy gel conducted by observing texture (consistency), color, and aroma. Observation of organoleptic characteristics is performed one time for each day during seven days of storage of sports energy gel both sample at room and the refrigerator temperature [5].

Homogeneity Analysis. Sports energy gel was observed its homogeneity by applying 1-2 drops of samples on glass objects then observed dispersion or spread. The homogeneous sample if the entire sample composition can disperse evenly [5].

2.5 Data analysis

Data were analyzed using SPSS 16.0 for Windows. Physicochemical analysis data of sports energy gel during storage period analyzed with One-Way and Two-Way ANOVA with a confidence level of 95%, which then continued with Duncan Multiple Range Test (DMRT) test. As for the differences in physicochemical characteristics of sports energy gel stored in room temperature and refrigerator temperature, an analysis conducted using the independent t-test with a confidence level of 95%. Data on sports energy gel sensory analysis during the storage period was analyzed descriptively through study and theoretical approach.

3 Results and discussion

3.1 Physicochemical analysis of sport energy gel

Acidity (pH). The measurement of the pH value of the sports energy gel sample over a 7-day storage period shows a sharp decline in the first and second days of storage in all samples (both stored at room and refrigerator temperature). The sports energy gel with the addition of xanthan gum stored at room temperature (H_1T_1) indicates a slight increase in pH value on the 4th day until the 6th day and decreases on the 7th day of storage. The sample

stored in the refrigerator temperature (H_1T_2) shows that its pH value continues to decline until the 7th day of storage. The pH value of a sports energy gel with the addition of pectin stored at room temperature (H_2T_1) still shows a decline in pH until day six, and a slight increase on the 7th day of observation.

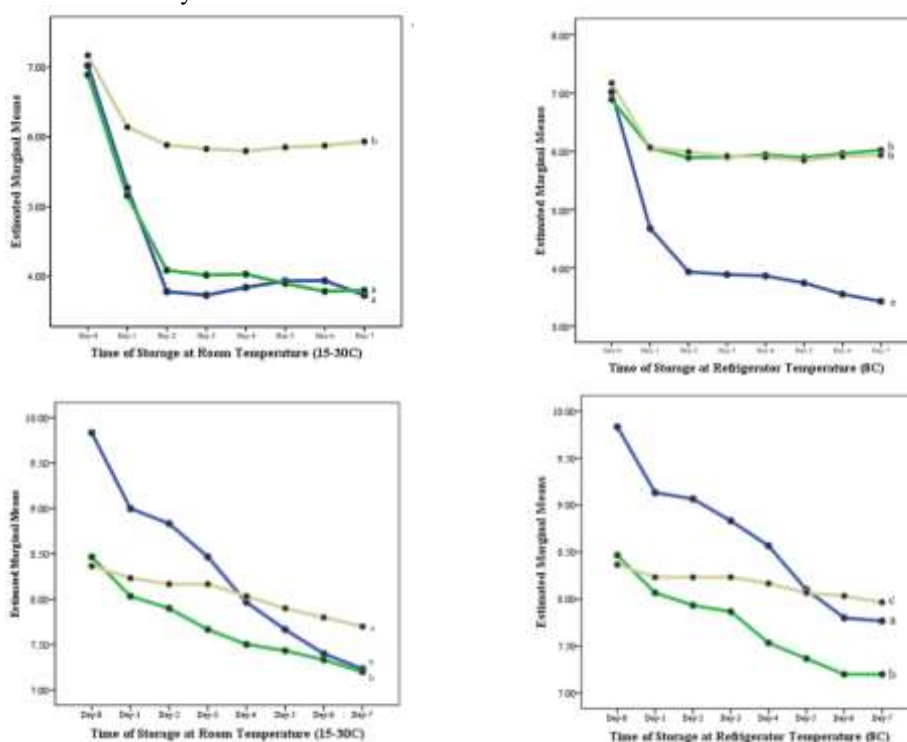

Fig. 1. a. The pH of Sports Energy Gel during Storage at Room Temperature. b. The pH of Sports Energy Gel during Storage at Refrigerator Temperature. c. Total Soluble Solid of Sport Energy Gel during Storage at Room Temperature. d. Total Soluble Solid of Sport Energy Gel during Storage at Refrigerator Temperature.

The difference means test between-subject effect using *Two Way ANOVA*. Comparison among treatments for a combination of time storage and type of hydrocolloids is significant at level 0.05 ($p=0.0001$). Comparison among treatment for time storage only is significant at level 0.05 ($p=0.0001$). A comparison among treatment for a type of hydrocolloids only is significant at level 0.05 ($p=0.0001$).

The sports energy gel with the addition of pectin stored at the refrigerator temperature (H_2T_2) showed a slight increase in the 3rd day and decreased on the 5th day, although then the pH value slightly increased until the 7th day of observation. The sports energy gel with the addition of CMC stored at room temperature (H_3T_1) shows a decline until the 4th day, then a little up until the 7th day of observation. The sports energy gel with the addition of CMC stored at the refrigerator temperature (H_3T_2) also shows a decline until day five then the pH value increase until the 7th day of observation (**Fig. 1a & 1b**).

Different test results using the independent t-test show no significant difference in the pH value between the sports energy gel stored at room temperature or refrigerator temperature ($p = 0.603$). However, different test results for each day of observation show that there is a

significant difference between the pH value of sports energy gel stored at room temperature and the refrigerator temperature, showed by a p-value < 0.05 (p = 0.0001) (Table 2).

Table 2. Physical Characteristics of Sport Energy Gel during Storage at Different Temperature.

Day	Type of Hydrocolloids	pH			Total Soluble Solid		
		Storage Temperature [§] (§)		P-Value	Storage Temperature [§] (§)		P-Value
		15-30°C (T ₁)	8°C (T ₂)		15-30°C (T ₁)	8°C (T ₂)	
0	H ₁	7.02 ± 0.026 ^a		0.0001*(#)	9.83 ± 0.153 ^a		0.0001*(#)
	H ₂	6.89 ± 0.010 ^b			8.47 ± 0.058 ^a		
	H ₃	7.17 ± 0.020 ^c			8.37 ± 0.115 ^b		
1	H ₁	5.27 ± 0.715 ^a	6.14 ± 0.010 ^a	0.151 ^{ns} (#)	9.00 ± 0.100 ^a	9.13 ± 0.058 ^a	0.001*(#)
	H ₂	6.06 ± 0.020 ^a	6.14 ± 0.010 ^a	0.0001*(^)	9.13 ± 0.058 ^a	8.23 ± 0.252 ^b	0.0001*(^)
	H ₃	5.27 ± 0.715 ^a	6.07 ± 0.020 ^b	0.0001*(v)	9.00 ± 0.100 ^b	8.23 ± 0.208 ^b	0.473 ^{ns} (v)
2	H ₁	3.78 ± 0.075 ^a	5.88 ± 0.031 ^a	0.0001*(#)	8.90 ± 0.115 ^a	9.07 ± 0.115 ^a	0.0001*(#)
	H ₂	3.93 ± 0.100 ^b	5.88 ± 0.031 ^b	0.0001*(^)	7.93 ± 0.115 ^b	8.17 ± 0.058 ^b	0.0001*(^)
	H ₃	4.09 ± 0.035 ^c	5.99 ± 0.010 ^b	0.0001*(v)	7.90 ± 0.100 ^c	8.23 ± 0.058 ^c	0.231 ^{ns} (v)
3	H ₁	3.73 ± 0.035 ^a	5.83 ± 0.023 ^a	0.0001*(#)	8.47 ± 0.058 ^a	8.83 ± 0.058 ^a	0.001*(#)
	H ₂	3.89 ± 0.051 ^b	5.83 ± 0.023 ^b	0.0001*(^)	7.87 ± 0.153 ^b	8.17 ± 0.058 ^b	0.0001*(^)
	H ₃	4.02 ± 0.021 ^c	5.92 ± 0.017 ^b	0.0001*(v)	7.67 ± 0.208 ^c	8.23 ± 0.115 ^c	0.026*(v)
4	H ₁	3.84 ± 0.105 ^a	5.80 ± 0.045 ^a	0.0001*(#)	7.97 ± 0.058 ^a	8.57 ± 0.058 ^a	0.0001*(#)
	H ₂	3.86 ± 0.078 ^b	5.80 ± 0.045 ^b	0.0001*(^)	7.53 ± 0.153 ^b	8.04 ± 0.069 ^b	0.0001*(^)
	H ₃	4.03 ± 0.070 ^c	5.90 ± 0.006 ^b	0.0001*(v)	7.50 ± 0.105 ^b	8.16 ± 0.053 ^c	0.0001*(v)
5	H ₁	3.93 ± 0.292 ^a	5.85 ± 0.010 ^a	0.0001*(#)	7.67 ± 0.231 ^a	8.10 ± 0.100 ^a	0.024*(#)
	H ₂	3.74 ± 0.559 ^b	5.85 ± 0.010 ^{ab}	0.0001*(^)	7.36 ± 0.118 ^{ab}	7.90 ± 0.100 ^b	0.0001*(^)
	H ₃	3.90 ± 0.190 ^c	5.85 ± 0.025 ^b	0.0001*(v)	7.45 ± 0.047 ^b	8.06 ± 0.078 ^b	0.0001*(v)
6	H ₁	3.94 ± 0.366 ^a	5.87 ± 0.040 ^a	0.0001*(#)	7.40 ± 0.100 ^a	7.80 ± 0.300 ^a	0.003*(#)
	H ₂	3.55 ± 0.691 ^a	5.87 ± 0.040 ^b	0.0001*(^)	7.20 ± 0.173 ^a	7.80 ± 0.100 ^b	0.006*(^)
	H ₃	3.78 ± 0.341 ^b	5.91 ± 0.114 ^b	0.0001*(v)	7.33 ± 0.115 ^b	8.02 ± 0.029 ^b	0.0001*(v)
7	H ₁	3.73 ± 0.320 ^a	5.93 ± 0.068 ^a	0.0001*(#)	7.23 ± 0.153 ^a	7.77 ± 0.306 ^a	0.010*(#)
	H ₂	3.43 ± 0.587 ^a	5.93 ± 0.068 ^b	0.0001*(^)	7.20 ± 0.265 ^a	7.70 ± 0.173 ^b	0.018*(^)
	H ₃	3.80 ± 0.495 ^b	5.94 ± 0.006 ^b	0.0001*(v)	7.20 ± 0.100 ^b	7.97 ± 0.058 ^b	0.0001*(v)

*Significant difference mean at the level of 0.05 (ns = not significant)

The difference means test using *One Way Anova*

(#) comparison among treatment in room temperature

(^) comparison among treatment in refrigerator temperature

The difference means test using *Independent T-Test*

(§) comparison between the mean of treatment in different storage temperature (p=0.603; p=0.583)

(v) comparison between the mean of treatment within each time of storage

Letter notation applies to have the mean of each treatment group

Notation differences show significant mean differences

The study results also show that the addition of different types of hydrocolloids in the sports energy gel formulation can make significantly different pH changes throughout 7-days of storage in both room and refrigerator temperature (p = 0.0001). The advanced test using DMRT showed that the sports energy gel added by CMC and stored at room temperature had a significantly higher pH value than those added xanthan gums and pectin. It is indicated with the difference in the letter notation. (Fig. 1a). As for the results of further testing on the sports energy gel stored at the refrigerator temperature indicates that the sports energy gel added xanthan gum has a higher pH value significantly when compared with the added pectin or CMC (Fig. 1b).

The analysis results then strengthen by an analysis of variance in each temperature treatment group in every day of observation. There is a significant difference in pH value on

every day of observation in both the temperature treatment groups (T_1 and T_2); both the sports energy gel add xanthan gum, pectin, nor CMC (H_1 , H_2 , and H_3). It is showed with a value of $p < 0.05$ ($p = 0.0001$), except on a sport energy gel that is stored at room temperature on the 1st day of storage showing the value $p > 0.05$ ($p = 0.151$) (**Table 2**).

The results of this study support similar research conducted in 2015 on the tomato-carrot juice blend. The study results stated that there was no significant difference between the storage at room temperature and room temperature in the sample. The sample stored in the refrigerator temperature shows a more stable pH than the sample stored at room temperature. However, during the storage period, fluctuating pH changes occur, but it appears to be a sharp decline in the second week of storage, both stored at room temperature or refrigerator temperature. This research also shows that the pH value of samples stored in the refrigerator temperature is higher when compared to the pH of samples stored at room temperature.[7]

Before storage, the addition of different hydrocolloids on the sports energy gel shows the pH values varying and significantly different ($P = 0.0001$). It attributes to the presence of a dose of the same hydrocolloid addition to each type to show significant pH differences even though the dose add in small quantities (0.1% w/v). It is supported by research that has conducted in the year 2012, which shows the results that the addition of xanthan gum and carrageenan with different addition doses is incapable of giving effect to the pH value and chemical composition of yogurt samples.[8] Similar with the result of the study on aloevera-lemon functional drink that showed a significant decrease during storage periods.[9] This study's results differed from the research done on yogurt samples added by several different stabilizer types, where the research results showed a pH value that did not differ significantly.[10] The decrease in pH value during storage is associated with a microbiological activity that mainly occurs in samples stored at room temperature. During the storage period in room temperature will increase the rate of breakdown of carbohydrates by microorganisms that will ultimately increase the total levels of acid in the product and decrease the pH value.[11]

Total Soluble Solid (TSS). Measurement of TSS of sports energy gel during the 7-day storage period results in a sharp decrease on the 1st day in the sample of the added xanthan gum, both stored in room temperature and the refrigerator temperature. Sports energy gel added pectin and CMC showed a decrease in total soluble solid but not as sharp as the sport of energy gel added xanthan gum. Sports energy gel both are stored at room temperature and in the refrigerator temperature (H_1T_1 ; H_1T_2 ; H_2T_1 ; H_2T_2 ; H_3T_1 ; and H_3T_2) shows a consistent decrease in total soluble solids until the 7th day of observation. (**Fig. 1c & 1d**)

The results of the different tests using the independent t-test showed no significant differences in TSS between the sports energy gel stored at room or refrigerator temperature ($p = 0.583$). However, different test results for each day of observation indicate that there is a significant difference in TSS between sport energy gels stored at room and refrigerator temperature on the 3rd day of observation, indicated by p-value < 0.05 ($p = 0.026$; 0.024 ; 0.0001 ; 0.0001 ; and 0.0001). The TSS of sports energy gel stored at room and the refrigerator temperature on the 1st and second-day observations showed no significant difference ($p = 0.473$ and 0.231) (**Table 2**).

ANOVA analysis mentioned that the addition of different types of hydrocolloids to the sports energy gel formulations could show significantly different changes in TSS throughout storage in both room and refrigerator temperature ($p = 0.0001$). The DMRT test results showed that any sports energy gel that added different hydrocolloid types stored at room temperature had significantly different total soluble solids. It indicates the difference in the letter notation (**Fig. 1c & 2d**).

Table 3. Observation of organoleptic characteristics of Sport Energy Gel during storage.

Day	Treatment	Characteristics			
		Color	Odor	Thickness	Physical Appearance
0	H ₁ T ₁	Light purple +	Cucumber +++	+++	Normal
	H ₂ T ₁	Light purple ++	Cucumber +++	+	Normal
	H ₃ T ₁	Light purple +	Cucumber +++	++	Normal
3	H ₁ T ₁	Purple + ; cloudy ++	Cucumber + ; sour ++	++++	Froth +++ ; fattened +
	H ₂ T ₁	Purple + ; cloudy +	Cucumber + ; sour ++	+++	Froth ++ ; fattened +
	H ₃ T ₁	Purple + ; cloudy +	Cucumber + ; sour ++	++	Froth +
	H ₁ T ₂	Light purple ++	Cucumber ++	++	Normal
	H ₂ T ₂	Light purple ++	Cucumber ++	+	Normal
	H ₃ T ₂	Light purple +	Cucumber ++	+	Normal
5	H ₁ T ₁	Purple + ; cloudy +++	Sour +++	++++	Froth ++++ ; fattened ++ ; smoky
	H ₂ T ₁	Purple + ; cloudy ++	Sour +++	+++	Froth ++ ; fattened ++
	H ₃ T ₁	Purple + ; cloudy ++	Sour +++	++	Froth ++
	H ₁ T ₂	Light purple ++	Cucumber + ; Light sour +	++	Sedikit fattened
	H ₂ T ₂	Light purple ++	Cucumber + ; Light sour +	+	Sedikit fattened
	H ₃ T ₂	Light purple +	Cucumber + ; Light sour +	+	Sedikit fattened
7	H ₁ T ₁	Purple ++ ; cloudy +++	Sour +++++	++++	Froth ++++ ; fattened ++ ; smoky
	H ₂ T ₁	Purple ++ ; cloudy ++	Sour +++++	+++	Froth ++ ; fattened ++
	H ₃ T ₁	Purple ++ ; cloudy ++	Sour +++++	++	Froth ++ ; fattened +
	H ₁ T ₂	Light purple ++	Cucumber + ; Light sour ++	++	Sedikit fattened
	H ₂ T ₂	Light purple ++	Cucumber + ; Light sour ++	+	Sedikit fattened
	H ₃ T ₂	Light purple +	Cucumber + ; Light sour ++	+	Sedikit fattened

The results of this study were in line with the research conducted in 2015 on the tomato drink-carrot juice blend, which stated that there was no significant total soluble solid difference between the samples stored at room and the refrigerator temperature.[7] Another study on *Aloe vera* drinks stored for 60 days showed that a significant decrease in TSS value occurred in all treatments during storage.[12] Total soluble Solid (TSS) is the overall amount of solids dissolved in a solution, such as some types of sugar (sucrose, fructose, and glucose) or other solids such as pectin and certain minerals.[13] In a beverage product that adds with hydrocolloid, the total soluble solid will increase, and its value will differ for each hydrocolloid type. The hydrocolloid structure containing a linear and water-soluble polysaccharides will hydrolyze due to the processing process, which can ultimately improve the simple sugar that appears to increase the TSS value.[14]

3.2 Sensory analysis of sport energy gel

Organoleptic Changes during Storage. Observations of the organoleptic characteristics of the sports energy gel are conducted on 4 points of time (3rd, 5th, and 7th days) during the seven day-period storage for each temperature treatment group (**Table 3**).

The observed characteristics of organoleptic changes include color, aroma, viscosity, and physical appearance of sports energy gel. In general, organoleptic characteristics of the sports energy gel store at the refrigerator temperature and the room temperature decreased during the storage period. The characteristics of organoleptic sports energy gel stored at room temperature more rapidly decrease when compared with the sports energy gel stored at the refrigerator temperature. The characteristics of sport energy gels stored in refrigerators tend to be more stable and decrease slower during storage periods. During storage, the color of the sports energy gel stored at room temperature changes to be darker than those stored at the refrigerator temperature. The cucumber aroma that is a smell to the sports energy gel stored at the refrigerator temperature can last longer than stored at room temperature. The pungent acid aroma is accompanied by froth and smoky when the lid of the bottle opens, which shows in the sample of sports energy gel stored at room temperature.

The result of the sensory evaluation characteristic done in cloudy ready-to-drink Mulberry product showed that the physical appearance, color, flavor, texture, and the acceptability of the product did not differ significantly in a sample that adds xanthan gum and CMC. The research mentions that the type of hydrocolloids used does not affect the sensory parameters of the product. Although there are significant odor differences between the products that add xanthan gum or CMC.[15]

Homogeneity of Sport Energy Gel. Observation of the energy gel sports homogeneities is also performed on 4 points of time (3rd, 5th, and 7th day) during the seven day-period storage for each temperature treatment group. A gel product is said to be homogeneous when there is no coarse grain or split blob.[6]

Based on observations, the results show that the homogeneity of the sports energy gel stored at room temperature or room temperature decreased during the storage period. The sports energy gel that stores at room temperature indicates the agglomeration of Chia seeds on the surface on day-3 of storage and increases until 7th-day storage. The sports energy gel that stores at the refrigerator temperature also begins to show a reduction in Chia seed's homogeneity in the base of the bottle on day-3 of storage and consistent until the 7th day of storage. There was no stability in the gel homogenized; the sports energy gel product in this study associated with the low number of hydrocolloids added in the product so that the product's homogeneity decreased faster during the duration of storage. Unlike the results of this study, the research on the Chinese scalloped extract gel shows more stable homogeneity of the gel during the storage period.[16] The limitation of this study is there is no physico-chemical and sensory as the gold standard to assess the suitability of the sport energy gel characteristics produced.

4 Conclusion

The energy gel sports storage added by a variety of hydrocolloids for seven-days with different storage temperatures may result in significant physical and sensory characteristics. Seven days of storage at room and the refrigerator temperature can significantly lower the pH value and total soluble solid. Sensory characteristics in the form of color, aroma, viscosity, natural tone and homogeneity of sports energy gel stored at room and the refrigerator temperature show a noticeable decline. The sports energy gel that stores at the refrigerator temperature also decreases sensory quality and homogeneity but appears slower. Researchers suggest that there is need a further research to study appropriate processing methods to enhance better the physicochemical and sensory characteristics and the longer shelf life of the energy gel. Besides, researchers also suggested that there is a need to test advanced sports energy gel products in vivo and examine their impact on living beings.

References

- [1] Julio C, Andr C, Sof C, Ripoll S. Development of mango (*Mangifera indica* L.) energy drinks. *RevFacNacAgron*. 2017;70(1):8115–21.
- [2] Rachna M, Faridabad S, Rachna M, Faridabad S. Product development, nutrient and sensory analysis of sports drink based on chia seeds (*Salvia hispanica* L.). *Int J Physiol Nutr Phys Educ*. 2019;4(2):187–90.
- [3] Manarisip T, Yamlean PVY, Lolo WA. Formulasi dan Uji Efektivitas Antibakteri Sediaan Gel Ekstrak Etanol Daun Kersen (*Muntingia calabura* L.) SEBAGAI. *Pharmacon*. 2019;8(3):165–75.
- [4] Ihsan, Farihul & Wahyudi A. Teknik Analisis Kadar Sukrosa pada Buah Pepaya. *Bul Tek Pertan*. 2010;15(1):10–2.
- [5] Daswi DR, Stevani H, Santi E, Farmasi J, Kemenkes P. Uji Stabilitas Mutu Fisik Sediaan Masker Gel Wajah dari Ekstrak Daun Belimbing Wuluh (*Averrhoa bilimbi*, L) dengan Variasi Konsentrasi Carbopol. *Media Farm*. 2018;XIV(1):85–92.
- [6] Kumesan YAN, Yamlean PVY, Supriati HS, Studi P, Unsrat F. Formulasi dan Uji Aktivitas Gel Antijerawat Ekstrak Umbi Bakung (*Crinum asiaticum* L.) Terhadap Bakteri *Staphylococcus Aureus* Secara In Vitro. *Pharmacon*. 2013;2(02):18–27.
- [7] Nwaokoro OG, Akanbi CT. Effect of the Addition of Hydrocolloids to Tomato-Carrot Juice Blend. *J Nutr Heal Food Sci*. 2015;3(1):1–10.
- [8] N Hematyar, AM Samarin HP and AE. Effect of Gums on Yogurt Characteristics. *World Appl Sci J*. 2019;20(5):661–5.
- [9] Kausar H, Parveen S, Saeed S, Ishfaq B, Ali MA. Development and Standardization of Ready to Serve Aloe vera- Lemon Functional Drink. 2016;10(4):47–52.
- [10] Sobhay ATH, Awad RA, Hassan ZMR E-BO. Properties of Drinking Yoghurt using Different Types of Stabilizers. *Arab Univ J Agric Sci*. 2019;27(1):431–40.
- [11] Ashaye, OA, Taiwo OO AG. Effect of local preservative (*Aframomum danielli*) on the chemical and sensory properties of stored warakanshi. *African J Agric Res*. 2006;1(1):010–6.
- [12] Masood MA, Shah F, Bashir S, Jamil R. Effect of storage on the physiochemical and antioxidant properties of Aloe vera drink. *Int J Food Sci Nutr*. 2019;4(4):201–5.
- [13] LS Magwazaa & UL Opara. Analytical methods for determination of sugars and sweetness of horticultural products — A review. *Sci Hortic (Amsterdam)* [Internet]. 2015;184:179–92. Available from: <http://dx.doi.org/10.1016/j.scienta.2015.01.001>
- [14] N H R Parnanto, B Yudhistira SRP and AP. The effect of CMC and arabic gum stabilizer combination on the characteristics of soursop velva (*Annona muricata* L.) The effect of CMC and ara-

- bic gum stabilizer combination on the characteristics of soursop velva (*Annona muricata* L.). In: IOP Conference Series: Earth and Environmental Science 142. 2018. p. 1–6.
- [15] Suthida A, Sirikhwan T. Effects of types and amounts of stabilizers on physical and sensory characteristics of cloudy ready-to-drink mulberry fruit juice. *Food Sci Nutr.* 2015;3(3):213–20.
- [16] NA Sayuti. Artikel Riset Formulasi dan Uji Stabilitas Fisik Sediaan Gel Ekstrak Daun Ketepeng Cina (*Cassia alata* L.). *J Kefarmasian Indones.* 2015;5(2):74–82.

Proceedings of the 5th International Seminar on Public Health and Education (ISPHE 2020)

22 July 2020, Universitas Negeri Semarang, Semarang, Indonesia

5th ISPHE 2020

Copyright © 2020 EAI, European Alliance for Innovation

www.eai.eu

<http://isphe.unnes.ac.id/>

ISBN: 978-1-63190-262-8

EAI Computing and Communication in Emerging Regions - CCER

The EAI Computing and Communication in Emerging Regions Series have already published proceedings from more than 20 conferences of various scopes. In line with EAI's values of equality and openness, their mission is to give greater visibility to research and innovation from emerging regions and share the knowledge worldwide. The audience for the proceedings consists of researchers, industry professionals, graduate students as well as practitioners in various fields. CCER harnesses the Open Access platform to simultaneously guarantee free exposure and distribution, under the Creative Commons license. In addition to being available in European Union Digital Library, the proceedings are disseminated to an even wider audience by being indexed in ProQuest, CNKI, Google Scholar and EBSCO.

European Alliance for Innovation

EAI is a non-profit organization with free membership and the largest open professional society for advancing research careers through community collaboration and fair recognition. Members benefit from finding feedback and mentorship for their work and they are guaranteed to be evaluated fairly, transparently, and objectively through community.

ISBN: 978-1-63190-262-8

<http://eudl.eu/series/CCER> | www.eai.eu